

QUAD BILATERAL SWITCH

- HIGH SPEED
 $t_{PD} = 7 \text{ ns (TYP.) AT } V_{CC} = 5 \text{ V}$
- LOW POWER DISSIPATION
 $I_{CC} = 1 \mu\text{A (MAX.) AT } T_A = 25 \text{ }^\circ\text{C}$
- HIGH NOISE IMMUNITY
 $V_{NIH} = V_{NIL} = 28 \% V_{CC} \text{ (MIN.)}$
- LOW "ON" RESISTANCE
 $R_{ON} = 50 \Omega \text{ (TYP.) AT } V_{CC} = 9 \text{ V, } I_{I/O} = 100 \mu\text{A}$
- SINE WAVE DISTORTION
 $0.042\% \text{ (TYP.) AT } V_{CC} = 4 \text{ V } f = 1 \text{ KHz}$
- WIDE OPERATING VOLTAGE RANGE
 $V_{CC} \text{ (OPR)} = 2 \text{ V TO } 12 \text{ V}$
- PIN AND FUNCTION COMPATIBLE
 WITH 4066B

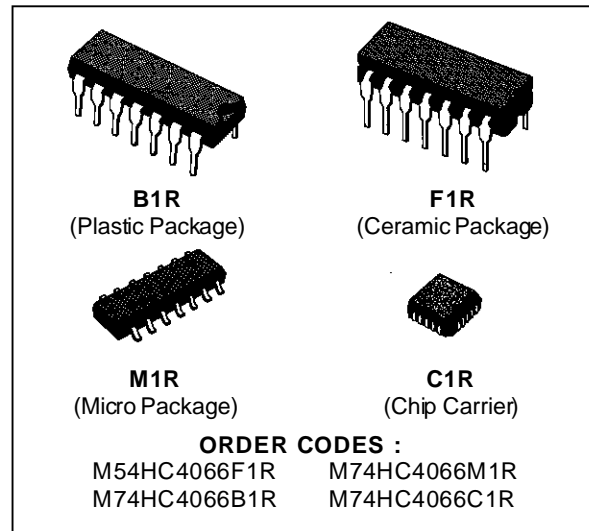

DESCRIPTION

The M54/74HC4066 is a high speed CMOS QUAD BILATERAL SWITCH fabricated in silicon gate C²MOS technology. It has high speed performance combined with true CMOS low power consumption.

The C input is provided to control the switch ; the switch is ON when the C input is held high and off when C is held low.

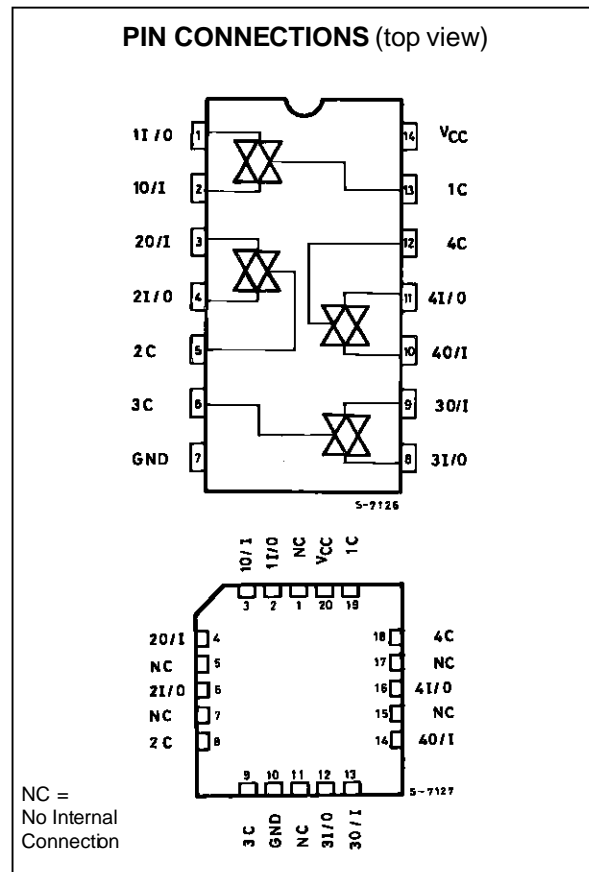

IEC LOGIC SYMBOL

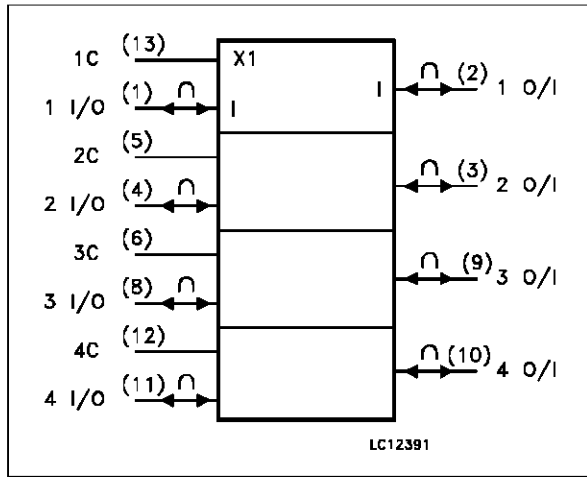

LOGIC DIAGRAM

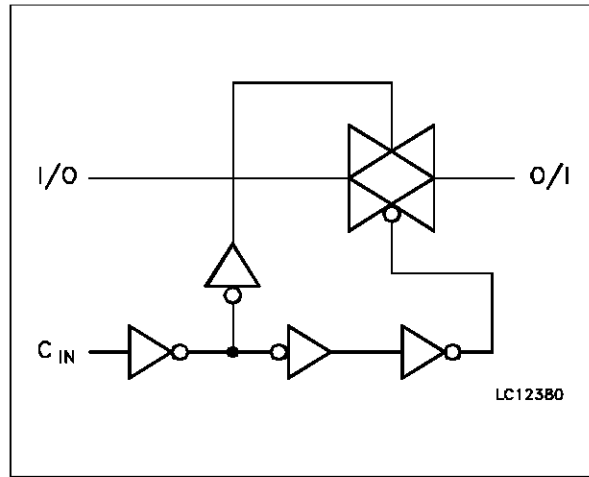

PIN DESCRIPTION

PIN No	SYMBOL	NAME AND FUNCTION
1, 4, 8, 11	1 to 4 I/O	Independent Inputs/Outputs
2, 3, 9, 10	1 to 4 O/I	Independent Outputs/Inputs
13, 5, 6, 12	1C to 4C	Enable Inputs (Active HIGH)
7	GND	Ground (0V)
14	V _{CC}	Positive Supply Voltage

TRUTH TABLE

CONTROL	SWITCH FUNCTION
H	ON
L	OFF

ABSOLUTE MAXIMUM RATINGS

Symbol	Parameter	Value	Unit
V _{CC}	Supply Voltage	-0.5 to +13	V
V _{IN}	DC Input Voltage	-0.5 to V _{CC} + 0.5	V
V _{I/O}	DC Input/Output Voltage	-0.5 to V _{CC} + 0.5	V
I _{OK}	Control Input DC Diode Current	± 20	mA
I _{I/O}	I/O DC Diode Current	± 20	mA
I _O	DC Output Source Sink Current Per Output Pin	± 25	mA
I _{CC} or I _{GND}	DC V _{CC} or Ground Current	± 50	mA
P _D	Power Dissipation	500 (*)	mW
T _{stg}	Storage Temperature	-65 to +150	°C
T _L	Lead Temperature (10 sec)	300	°C

Absolute Maximum Ratings are those values beyond which damage to the device may occur. Functional operation under these condition is not implied.

(*) 500 mW: ≙ 65 °C derate to 300 mW by 10mW/°C: 65 °C to 85 °C

RECOMMENDED OPERATING CONDITIONS

Symbol	Parameter	Value	Unit	
V _{CC}	Supply Voltage	2 to 12	V	
V _{IN}	Input Voltage (Control)	0 to V _{CC}	V	
V _{I/O}	Input/Output Voltage	0 to V _{CC}	V	
T _{op}	Operating Temperature: M54HC Series M74HC Series	-55 to +125 -40 to +85	°C °C	
t _r , t _f	Input Rise and Fall Time	V _{CC} = 2 V	0 to 1000	ns
		V _{CC} = 4.5 V	0 to 500	
		V _{CC} = 6 V	0 to 400	
		V _{CC} = 10 V	0 to 250	

DC SPECIFICATIONS

Symbol	Parameter	Test Conditions		Value						Unit	
		V _{CC} (V)		T _A = 25 °C 54HC and 74HC			-40 to 85 °C 74HC		-55 to 125 °C 54HC		
				Min.	Typ.	Max.	Min.	Max.	Min.		Max.
V _{IHC}	High Level Control Input Voltage	2.0		1.5			1.5		1.5		V
		4.5		3.15			3.15		3.15		
		9.0		6.3			6.3		6.3		
		12.0		8.4			8.4		8.4		
V _{ILC}	Low Level Control Input Voltage	2.0				0.5		0.5		0.5	V
		4.5				1.35		1.35		1.35	
		9.0				2.7		2.7		2.7	
		12.0				3.6		3.6		3.6	
R _{ON}	ON Resistance	4.5	V _{IN} = V _{IHC} V _{I/O} = V _{CC} to GND I _{I/O} ≤ 1 mA		96	170		200		250	Ω
		9.0			55	85		100		150	
		12.0			45	80		90		120	
		4.5	V _{IN} = V _{IHC} V _{I/O} = V _{CC} or GND I _{I/O} ≤ 1 mA		70	100		130		160	
		9.0			50	75		95		115	
		12.0			45	70		90		110	
ΔR _{ON}	Difference of ON Resistance Between Switches	4.5	V _{IN} = V _{IHC} V _{I/O} = V _{CC} or GND I _{I/O} ≤ 1 mA		10						Ω
		9.0			5						
		12.0			5						
I _{OFF}	Input/Output Leakage Current (SWITCH OFF)	12.0	V _{OS} = V _{CC} or GND V _{IS} = V _{CC} or GND V _{IN} = V _{ILC}			±0.1		±1		±2	μA
I _{Iz}	Switch Input Leakage Current (SWITCH ON, OUTPUT OPEN)	12.0	V _{OS} = V _{CC} or GND V _{IN} = V _{IHC}			±0.1		±1		±2	μA
I _{IN}	Control Input Current	6.0	V _{IN} = V _{CC} or GND			±0.1		±1		±1	μA
I _{CC}	Quiescent Supply Current	6.0	V _{IN} = V _{CC} or GND			1		10		20	μA
		9.0				4		40		80	
		12.0				8		80		160	

AC ELECTRICAL CHARACTERISTICS ($C_L = 50 \text{ pF}$, Input $t_r = t_f = 6 \text{ ns}$)

Symbol	Parameter	Test Conditions		Value						Unit	
		V _{CC} (V)		T _A = 25 °C 54HC and 74HC			-40 to 85 °C 74HC		-55 to 125 °C 54HC		
				Min.	Typ.	Max.	Min.	Max.	Min.		Max.
ø _{I/O}	Phase Difference Between Input and Output	2.0			10	50		65		75	ns
		4.5			4	10		13		15	
		9.0			3	8		10		13	
		12.0			3	7		9		10	
t _{pZL} t _{pZH}	Output Enable Time	2.0	R _L = 1KΩ		18	100		125		150	ns
		4.5			8	20		25		30	
		9.0			6	12		22		27	
		12.0			6	12		18		25	
t _{pLZ} t _{pHZ}	Output Disable Time	2.0	R _L = 1KΩ		20	115		145		175	ns
		4.5			10	23		29		35	
		9.0			8	20		25		30	
		12.0			8	18		22		27	
	Maximum Control Input Frequency	2.0	R _L = 1KΩ C _L = 15 pF V _{OUT} = 1/2 V _{CC}		30						MHz
		4.5			30						
		9.0			30						
		12.0			30						
C _{IN}	Input Capacitance				5	10		10		10	pF
C _{I/O}	Switch Terminal Capacitance				6						pF
C _{IOS}	Feed Through Capacitance				0.5						pF
C _{PD} (*)	Power Dissipation Capacitance				15						pF

(*) C_{PD} is defined as the value of the IC's internal equivalent capacitance which is calculated from the operating current consumption without load. (Refer to Test Circuit). Average operating current can be obtained by the following equation. I_{CC(opr)} = C_{PD} • V_{CC} • f_{IN} + I_{CC}

ANALOG SWITCH CHARACTERISTICS (GND = 0 V T_A = 25 °C)

Symbol	Parameter	Test Conditions			Value	Unit
		V _{CC} (V)	V _{IN} (Vp-p)		Typ.	
	Sine Wave Distortion (THD)	4.5	4	f _{IN} = 1 KHz R _L = 10 KΩ C _L = 50 pF	0.05	%
		9.0	8		0.04	
f _{MAX}	Frequency Response (Switch ON)	4.5	Adjust f _{IN} voltage to Obtain 0 dBm at V _{OS} .		200	MHz
		9.0	Increase f _{IN} Frequency until dB Meter reads -3dB R _L = 50 Ω C _L = 10 pF		200	
	Feedthrough Attenuation (Switch OFF)	4.5	V _{IN} is centered at V _{CC} /2. Adjust input for 0 dBm		-60	dB
		9.0	R _L = 600 Ω C _L = 50 pF f _{IN} = 1 MHz sine wave		-60	
	Crosstalk (Control Input to Signal Output)	4.5	R _L = 600 Ω C _L = 50 pF		60	mV
		9.0	f _{IN} = 1 MHz square wave (t _r = t _f = 6ns)		100	
	Crosstalk (Between Any Switches)	4.5	Adjust V _{IN} to Obtain 0 dBm at input		-60	dB
		9.0	R _L = 600 Ω C _L = 50 pF f _{IN} = 1 MHz sine wave		-60	

SWITCHING CHARACTERISTICS TEST CIRCUIT

t_{PLZ} , t_{PHZ} , t_{PZL} , t_{PZH} .

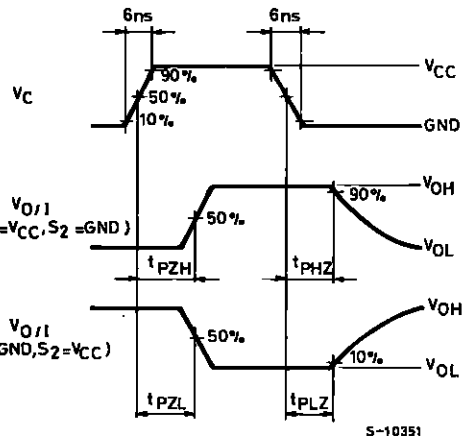
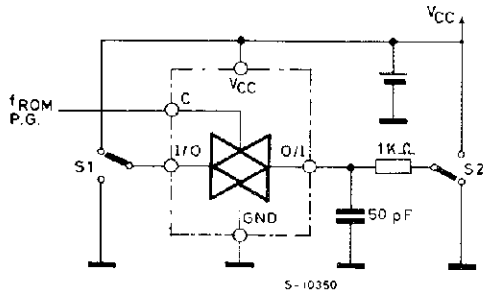

CROSSTALK (control to output)

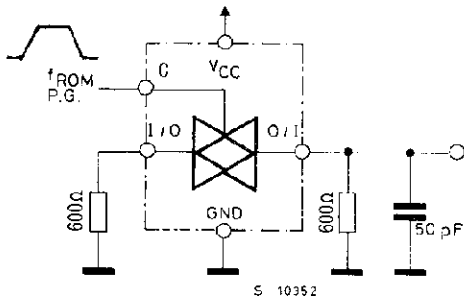

CROSSTALK BETWEEN ANY TWO SWITCHES

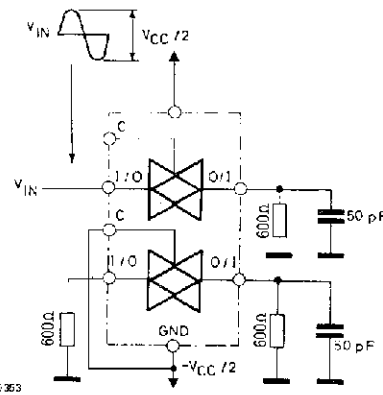

BANDWIDTH AND FEEDTHROUGH ATTENUATION

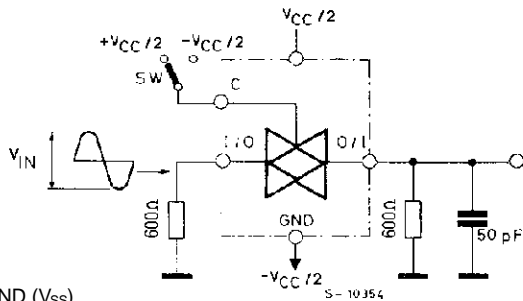

GND (V_{SS})

C_{I-O} C_{I/O}

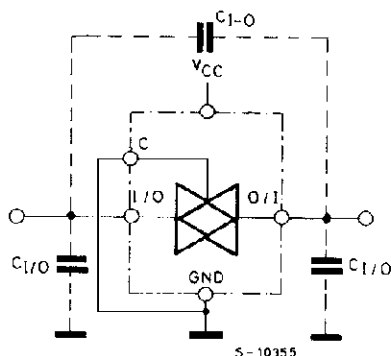

GND (V_{SS})

MAXIMUM CONTROL FREQUENCY

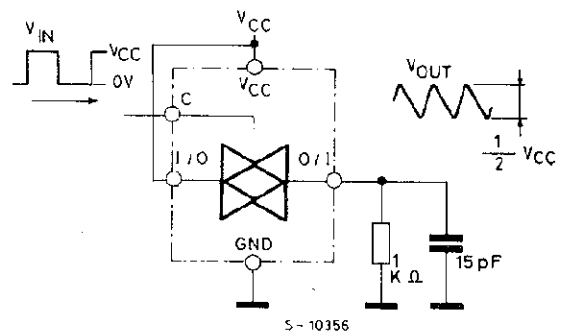

CHANNEL RESISTANCE (R_{ON})

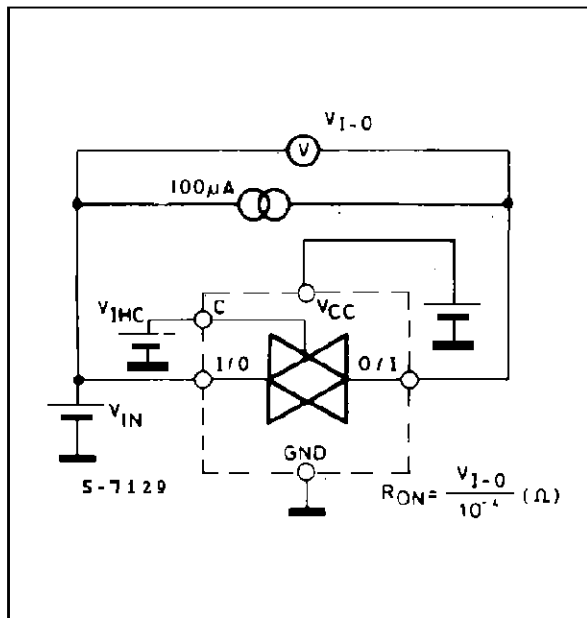

I_{CC} (Opr.)

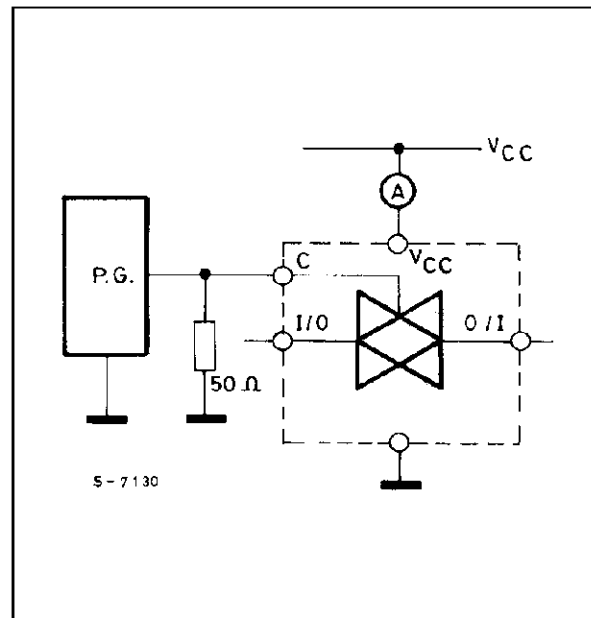

Plastic DIP14 MECHANICAL DATA

DIM.	mm			inch		
	MIN.	TYP.	MAX.	MIN.	TYP.	MAX.
a1	0.51			0.020		
B	1.39		1.65	0.055		0.065
b		0.5			0.020	
b1		0.25			0.010	
D			20			0.787
E		8.5			0.335	
e		2.54			0.100	
e3		15.24			0.600	
F			7.1			0.280
I			5.1			0.201
L		3.3			0.130	
Z	1.27		2.54	0.050		0.100

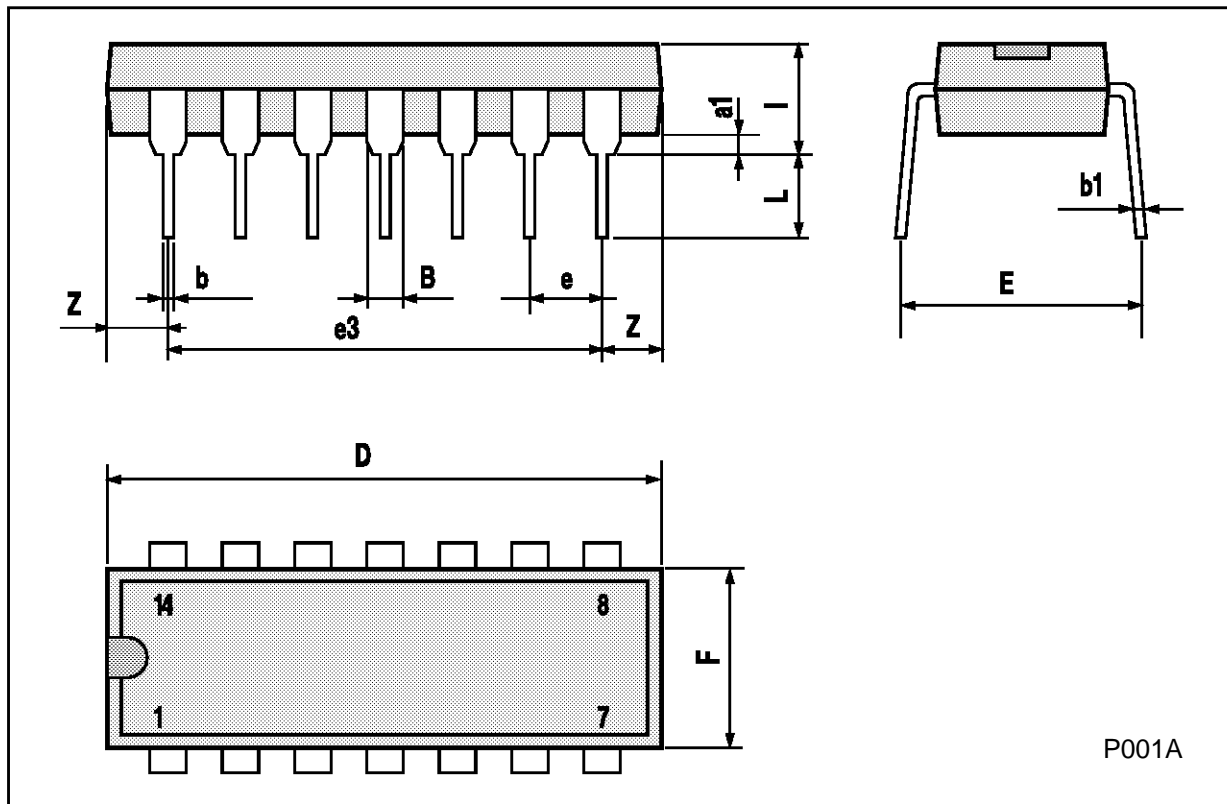

Ceramic DIP14/1 MECHANICAL DATA

DIM.	mm			inch		
	MIN.	TYP.	MAX.	MIN.	TYP.	MAX.
A			20			0.787
B			7.0			0.276
D		3.3			0.130	
E	0.38			0.015		
e3		15.24			0.600	
F	2.29		2.79	0.090		0.110
G	0.4		0.55	0.016		0.022
H	1.17		1.52	0.046		0.060
L	0.22		0.31	0.009		0.012
M	1.52		2.54	0.060		0.100
N			10.3			0.406
P	7.8		8.05	0.307		0.317
Q			5.08			0.200

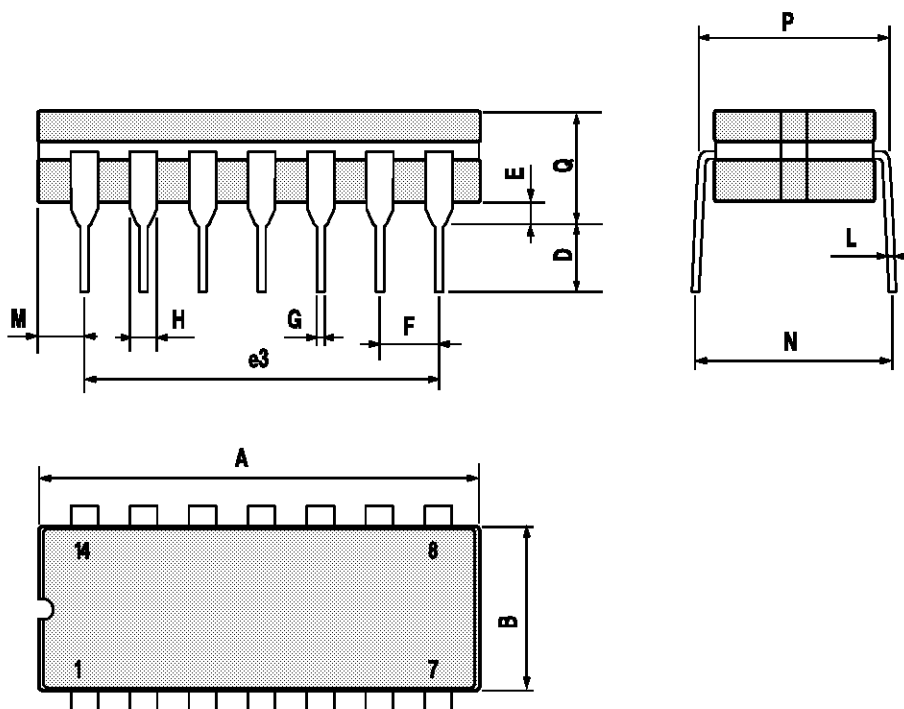

P053C

SO14 MECHANICAL DATA

DIM.	mm			inch		
	MIN.	TYP.	MAX.	MIN.	TYP.	MAX.
A			1.75			0.068
a1	0.1		0.2	0.003		0.007
a2			1.65			0.064
b	0.35		0.46	0.013		0.018
b1	0.19		0.25	0.007		0.010
C		0.5			0.019	
c1	45° (typ.)					
D	8.55		8.75	0.336		0.344
E	5.8		6.2	0.228		0.244
e		1.27			0.050	
e3		7.62			0.300	
F	3.8		4.0	0.149		0.157
G	4.6		5.3	0.181		0.208
L	0.5		1.27	0.019		0.050
M			0.68			0.026
S	8° (max.)					

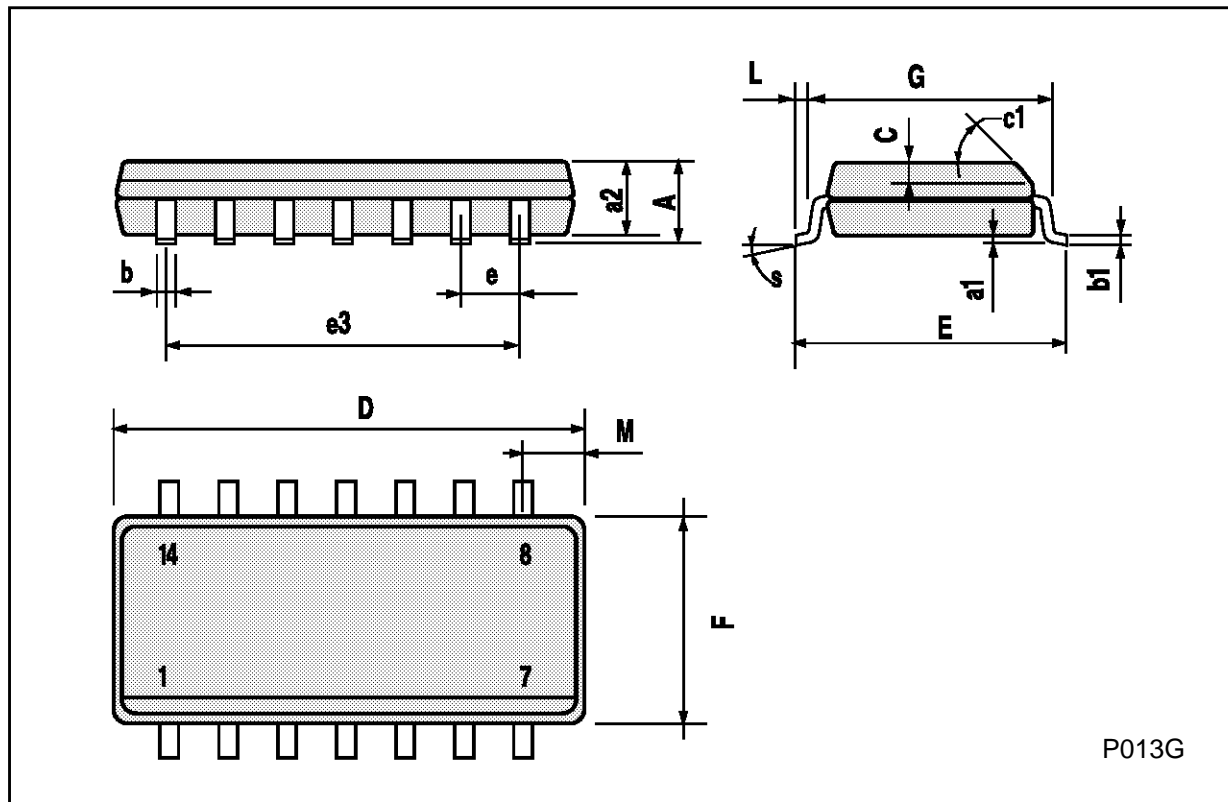

PLCC20 MECHANICAL DATA

DIM.	mm			inch		
	MIN.	TYP.	MAX.	MIN.	TYP.	MAX.
A	9.78		10.03	0.385		0.395
B	8.89		9.04	0.350		0.356
D	4.2		4.57	0.165		0.180
d1		2.54			0.100	
d2		0.56			0.022	
E	7.37		8.38	0.290		0.330
e		1.27			0.050	
e3		5.08			0.200	
F		0.38			0.015	
G			0.101			0.004
M		1.27			0.050	
M1		1.14			0.045	



Information furnished is believed to be accurate and reliable. However, SGS-THOMSON Microelectronics assumes no responsibility for the consequences of use of such information nor for any infringement of patents or other rights of third parties which may result from its use. No license is granted by implication or otherwise under any patent or patent rights of SGS-THOMSON Microelectronics. Specifications mentioned in this publication are subject to change without notice. This publication supersedes and replaces all information previously supplied. SGS-THOMSON Microelectronics products are not authorized for use as critical components in life support devices or systems without express written approval of SGS-THOMSON Microelectronics.

© 1994 SGS-THOMSON Microelectronics - All Rights Reserved

SGS-THOMSON Microelectronics GROUP OF COMPANIES

Australia - Brazil - France - Germany - Hong Kong - Italy - Japan - Korea - Malaysia - Malta - Morocco - The Netherlands -
Singapore - Spain - Sweden - Switzerland - Taiwan - Thailand - United Kingdom - U.S.A