

4 WORD X 4 BIT REGISTER FILE (3 STATE)

- HIGH SPEED
t_{PD} = 23 ns (TYP.) AT V_{CC} = 5 V
- LOW POWER DISSIPATION
I_{CC} = 4 μA (MAX.) AT T_A = 25 °C
- HIGH NOISE IMMUNITY
V_{NIH} = V_{NIL} = 28 % V_{CC} (MIN.)
- OUTPUT DRIVE CAPABILITY
10 LSTTL LOADS
- SYMMETRICAL OUTPUT IMPEDANCE
|I_{OH}| = I_{OL} = 4 mA (MIN.)
- BALANCED PROPAGATION DELAYS
t_{PLH} = t_{PHL}
- WIDE OPERATING VOLTAGE RANGE
V_{CC} (OPR) = 2 V TO 6 V
- PIN AND FUNCTION COMPATIBLE
WITH 54/74LS670

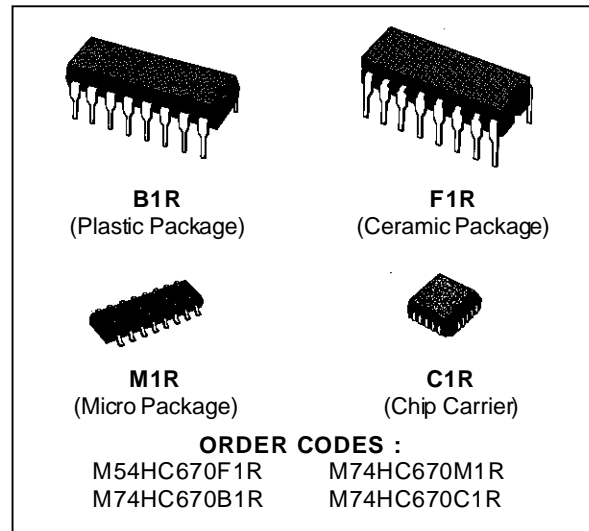

DESCRIPTION

The M54/74HC670 is a high speed CMOS 4 WORD X 4 BIT REGISTER FILE (3-STATE) fabricated in silicon gate C²MOS technology. It has the same high speed performance of LSTTL combined with true CMOS low power consumption. The M54HC/74HC670 is a 4 x 4 Register File organized as four words by four bits. Separate read and write inputs, both address and enable, allow simultaneous read and write operation. The 3-state outputs make it possible to connect up to 128 outputs to increase the word capacity up to 512 words. Any number of these devices can be operated in parallel to generate an n-bit length. All inputs are equipped with protection circuits against static discharge and transient excess voltage.

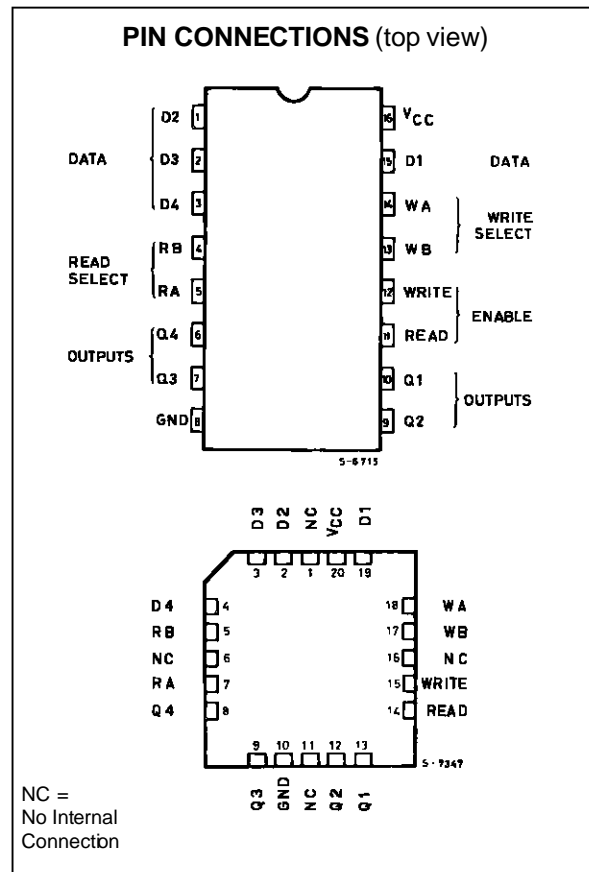

WRITE FUNCTION TABLE

WRITE INPUTS			WORDS			
WB	WA	WE	0	1	2	3
L	L	L	Q = D	Q0	Q0	Q0
L	H	L	Q0	Q = D	Q0	Q0
H	L	L	Q0	Q0	Q = D	Q0
H	H	L	Q0	Q0	Q0	Q = D
X	X	H	Q0	Q0	Q0	Q0

READ FUNCTION TABLE

READ INPUTS			OUTPUTS			
RB	RA	RE	Q0	Q1	Q2	Q3
L	L	L	W0B1	W0B2	W0B3	W0B4
L	H	L	W1B1	W1B2	W1B3	W1B4
H	L	L	W2B1	W2B2	W2B3	W2B4
H	H	L	W3B1	W3B2	W3B3	W3B4
X	X	H	Z	Z	Z	Z

Notes: 1 *: DON'T CARE Z: HIGH IMPEDANCE
 2 (Q = D) = THE FOUR SELECT INTERNAL FLIP FLOP OUTPUTS WILL ASSUME THE STATES APPLIED TO THE FOUR EXTERNAL DATA INPUTS.
 3 Q0 = THE LEVEL OF Q BEFORE THE INDICATED INPUT CONDITIONS WERE ESTABLISHED.
 4 W0B1 = THE FIRST BIT OF WORD 0, ETC.

LOGIC DIAGRAM

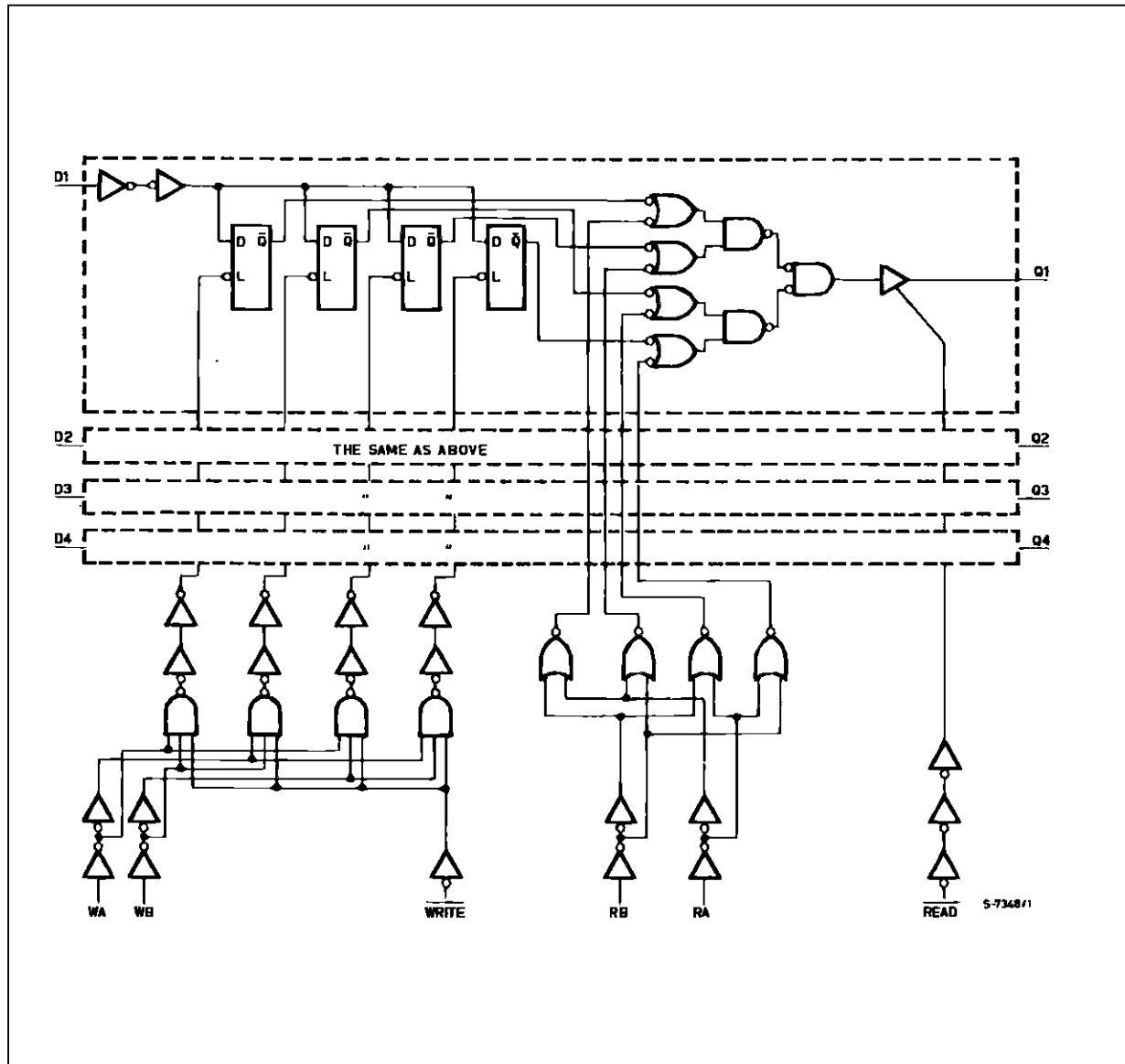

INPUT AND OUTPUT EQUIVALENT CIRCUIT

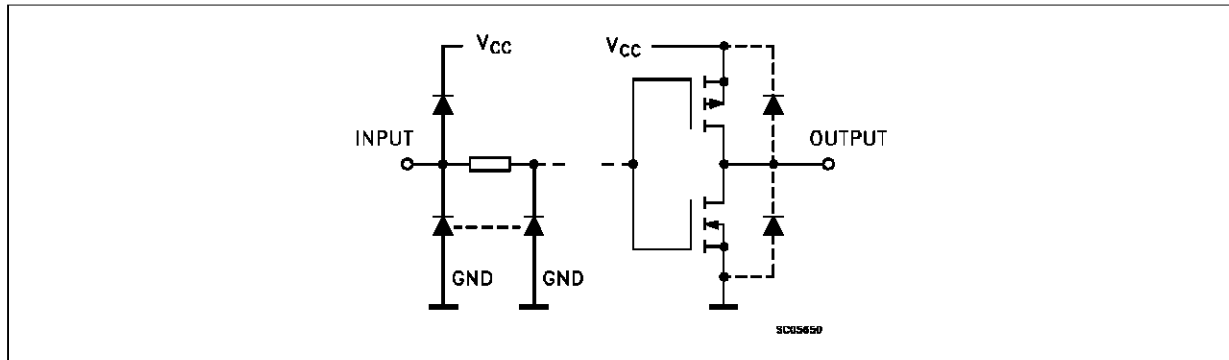

PIN DESCRIPTION

PIN No	SYMBOL	NAME AND FUNCTION
5, 4	RA, RB	Read Address Inputs
10, 9, 7, 6	Q1 to Q4	Data Outputs
11	\overline{RE}	3 State Output Read Enable Input (Active LOW)
12	\overline{WE}	Write Enable Input (Active LOW)
14, 13	WA, WB	Write Address Inputs
15, 1, 2, 3	D1 to D4	Data Inputs
7	GND	Ground (0V)
14	Vcc	Positive Supply Voltage

IEC LOGIC SYMBOL

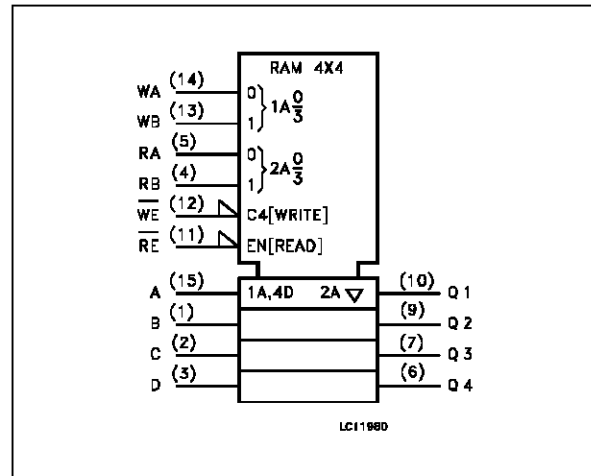

ABSOLUTE MAXIMUM RATINGS

Symbol	Parameter	Value	Unit
V _{CC}	Supply Voltage	-0.5 to +7	V
V _I	DC Input Voltage	-0.5 to V _{CC} + 0.5	V
V _O	DC Output Voltage	-0.5 to V _{CC} + 0.5	V
I _{IK}	DC Input Diode Current	± 20	mA
I _{OK}	DC Output Diode Current	± 20	mA
I _O	DC Output Source Sink Current Per Output Pin	± 25	mA
I _{CC} or I _{GND}	DC V _{CC} or Ground Current	± 50	mA
P _D	Power Dissipation	500 (*)	mW
T _{stg}	Storage Temperature	-65 to +150	°C
T _L	Lead Temperature (10 sec)	300	°C

Absolute Maximum Ratings are those values beyond which damage to the device may occur. Functional operation under these condition is not implied.
 (*) 500 mW: ≅ 65 °C derate to 300 mW by 10mW/°C: 65 °C to 85 °C

M54/M74HC670

RECOMMENDED OPERATING CONDITIONS

Symbol	Parameter	Value	Unit	
V_{CC}	Supply Voltage	2 to 6	V	
V_I	Input Voltage	0 to V_{CC}	V	
V_O	Output Voltage	0 to V_{CC}	V	
T_{op}	Operating Temperature: M54HC Series M74HC Series	-55 to +125 -40 to +85	°C °C	
t_r, t_f	Input Rise and Fall Time	$V_{CC} = 2\text{ V}$	0 to 1000	ns
		$V_{CC} = 4.5\text{ V}$	0 to 500	
		$V_{CC} = 6\text{ V}$	0 to 400	

DC SPECIFICATIONS

Symbol	Parameter	Test Conditions		Value						Unit		
				$T_A = 25\text{ °C}$ 54HC and 74HC			$-40\text{ to }85\text{ °C}$ 74HC		$-55\text{ to }125\text{ °C}$ 54HC			
				Min.	Typ.	Max.	Min.	Max.	Min.		Max.	
V_{IH}	High Level Input Voltage	V_{CC} (V)		1.5			1.5		1.5		V	
				3.15			3.15		3.15			
				4.2			4.2		4.2			
V_{IL}	Low Level Input Voltage	V_{CC} (V)				0.5		0.5		0.5	V	
						1.35		1.35		1.35		
						1.8		1.8		1.8		
V_{OH}	High Level Output Voltage	V_{CC} (V)	$V_I = V_{IH}$ or V_{IL}	$I_O = -20\text{ }\mu\text{A}$	1.9	2.0		1.9		1.9	V	
					4.4	4.5		4.4		4.4		
					5.9	6.0		5.9		5.9		
				4.5	$I_O = -4.0\text{ mA}$	4.18	4.31		4.13			4.10
						5.68	5.8		5.63			5.60
V_{OL}	Low Level Output Voltage	V_{CC} (V)	$V_I = V_{IH}$ or V_{IL}	$I_O = 20\text{ }\mu\text{A}$		0.0	0.1		0.1		0.1	V
						0.0	0.1		0.1		0.1	
						0.0	0.1		0.1		0.1	
				4.5	$I_O = 4.0\text{ mA}$	0.17	0.26		0.33		0.40	
						0.18	0.26		0.33		0.40	
I_I	Input Leakage Current	6.0	$V_I = V_{CC}$ or GND			± 0.1		± 1		± 1	μA	
I_{OZ}	3 State Output Off State Current	6.0	$V_I = V_{IH}$ or V_{IL} $V_O = V_{CC}$ or GND			± 0.5		± 5		± 5	μA	
I_{CC}	Quiescent Supply Current	6.0	$V_I = V_{CC}$ or GND			4		40		80	μA	

AC ELECTRICAL CHARACTERISTICS ($C_L = 50$ pF, Input $t_r = t_f = 6$ ns)

Symbol	Parameter	Test Conditions		Value						Unit	
		V _{CC} (V)		T _A = 25 °C 54HC and 74HC			-40 to 85 °C 74HC		-55 to 125 °C 54HC		
				Min.	Typ.	Max.	Min.	Max.	Min.		Max.
t _{TLH} t _{THL}	Output Transition Time	2.0			30	75		95		110	ns
		4.5			8	15		19		22	
		6.0			7	13		16		19	
t _{PLH} t _{PHL}	Propagation Delay Time (RA, RB - Qn)	2.0			96	185		230		280	ns
		4.5			24	37		46		56	
		6.0			20	31		39		48	
t _{PLH} t _{PHL}	Propagation Delay Time (WE - Qn)	2.0			108	220		275		330	ns
		4.5			27	44		55		66	
		6.0			23	37		47		56	
t _{PLH} t _{PHL}	Propagation Delay Time (Dn - Qn)	2.0			104	185		230		280	ns
		4.5			26	37		46		56	
		6.0			22	31		39		48	
t _{PZL} t _{PZH}	Output Disable Time	2.0	R _L = 1 KΩ		42	110		140		165	ns
		4.5			13	22		28		33	
		6.0			11	19		24		28	
t _{PLZ} t _{PHZ}	Output Disable Time	2.0	R _L = 1 KΩ		25	95		120		145	ns
		4.5			13	19		24		29	
		6.0			11	16		20		25	
t _{W(L)}	Minimum Pulse Width (WE)	2.0			16	75		95		110	ns
		4.5			4	15		19		22	
		6.0			3	13		16		19	
t _s	Minimum Set-up Time (Dn - WE) (WA, WB - WE)	2.0			12	50		65		75	ns
		4.5			3	10		13		15	
		6.0			3	9		11		13	
t _h	Minimum Hold Time (Dn - WE)	2.0				0		0		0	ns
		4.5				0		0		0	
		6.0				0		0		0	
t _h	Minimum Hold Time (WA, WB - WE)	2.0				5		5		5	ns
		4.5				5		5		5	
		6.0				5		5		5	
t _{latch}	Minimum Latch Time (WE - RA, RB)	2.0				5		5		5	ns
		4.5				5		5		5	
		6.0				5		5		5	
C _{IN}	Input Capacitance				5	10		10		10	pF
C _{PD} (*)	Power Dissipation Capacitance				96						pF

(*) C_{PD} is defined as the value of the IC's internal equivalent capacitance which is calculated from the operating current consumption without load. (Refer to Test Circuit). Average operating current can be obtained by the following equation. $I_{CC(opr)} = C_{PD} \cdot V_{CC} \cdot f_{IN} + I_{CC}$

SWITCHING CHARACTERISTICS TEST WAVEFORM

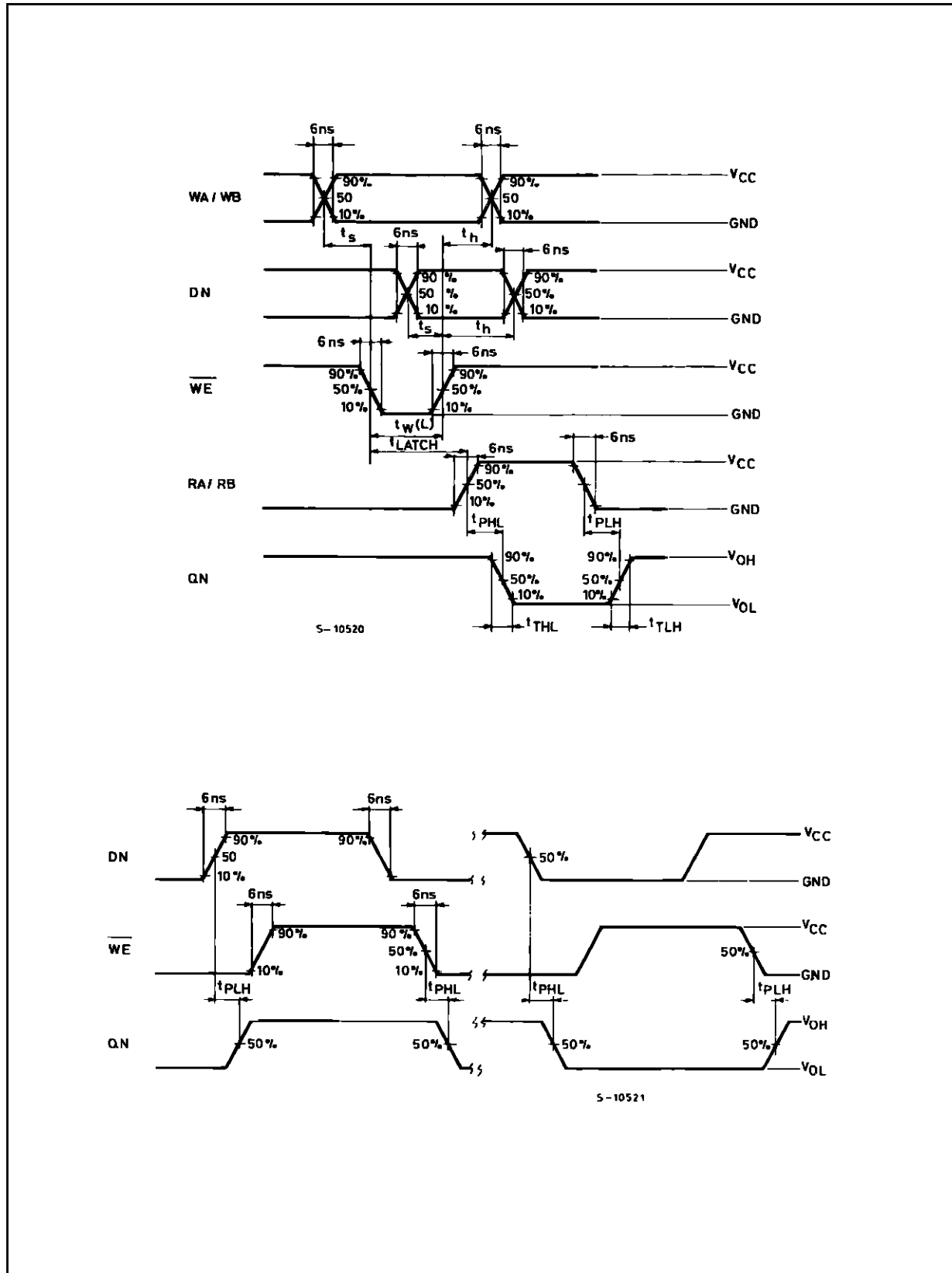

SWITCHING CHARACTERISTICS TEST WAVEFORM (continued)

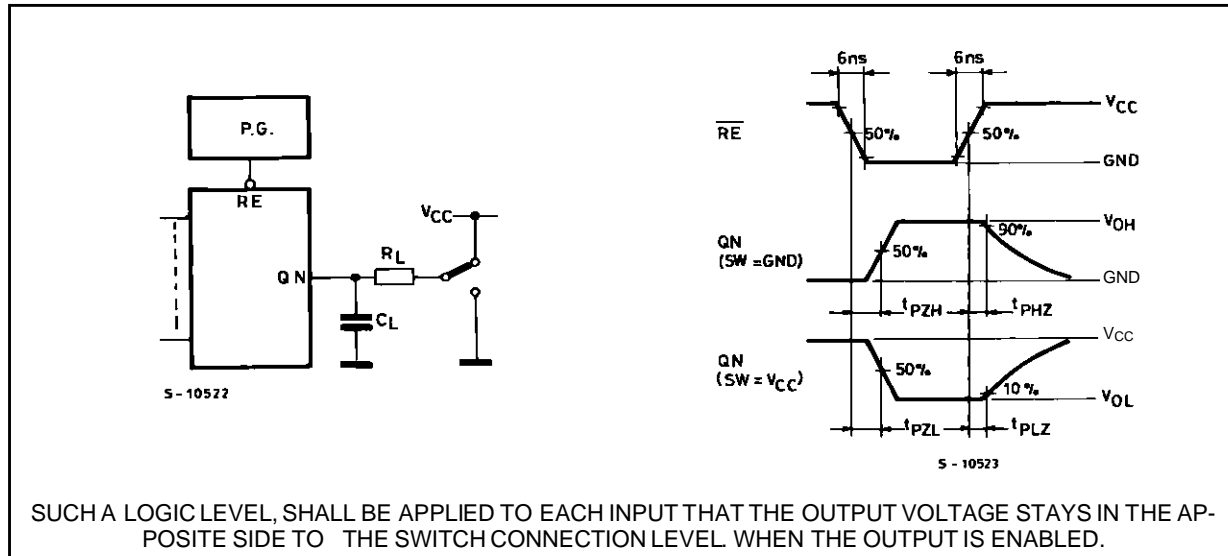

TEST CIRCUIT I_{CC} (Opr.)

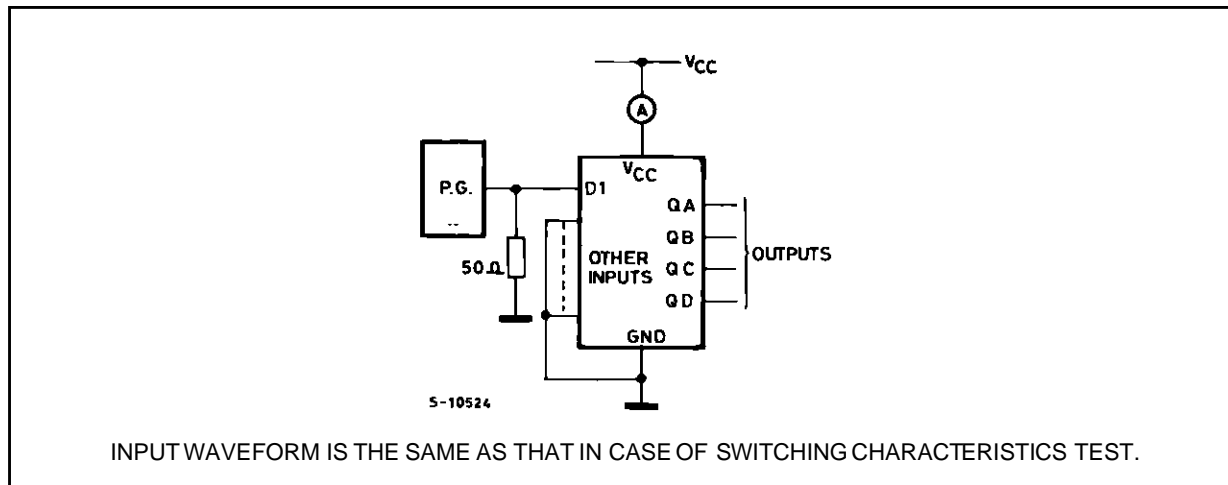

Plastic DIP16 (0.25) MECHANICAL DATA

DIM.	mm			inch		
	MIN.	TYP.	MAX.	MIN.	TYP.	MAX.
a1	0.51			0.020		
B	0.77		1.65	0.030		0.065
b		0.5			0.020	
b1		0.25			0.010	
D			20			0.787
E		8.5			0.335	
e		2.54			0.100	
e3		17.78			0.700	
F			7.1			0.280
I			5.1			0.201
L		3.3			0.130	
Z			1.27			0.050



P001C

Ceramic DIP16/1 MECHANICAL DATA

DIM.	mm			inch		
	MIN.	TYP.	MAX.	MIN.	TYP.	MAX.
A			20			0.787
B			7			0.276
D		3.3			0.130	
E	0.38			0.015		
e3		17.78			0.700	
F	2.29		2.79	0.090		0.110
G	0.4		0.55	0.016		0.022
H	1.17		1.52	0.046		0.060
L	0.22		0.31	0.009		0.012
M	0.51		1.27	0.020		0.050
N			10.3			0.406
P	7.8		8.05	0.307		0.317
Q			5.08			0.200



SO16 (Narrow) MECHANICAL DATA

DIM.	mm			inch		
	MIN.	TYP.	MAX.	MIN.	TYP.	MAX.
A			1.75			0.068
a1	0.1		0.2	0.004		0.007
a2			1.65			0.064
b	0.35		0.46	0.013		0.018
b1	0.19		0.25	0.007		0.010
C		0.5			0.019	
c1	45° (typ.)					
D	9.8		10	0.385		0.393
E	5.8		6.2	0.228		0.244
e		1.27			0.050	
e3		8.89			0.350	
F	3.8		4.0	0.149		0.157
G	4.6		5.3	0.181		0.208
L	0.5		1.27	0.019		0.050
M			0.62			0.024
S	8° (max.)					



P013H

PLCC20 MECHANICAL DATA

DIM.	mm			inch		
	MIN.	TYP.	MAX.	MIN.	TYP.	MAX.
A	9.78		10.03	0.385		0.395
B	8.89		9.04	0.350		0.356
D	4.2		4.57	0.165		0.180
d1		2.54			0.100	
d2		0.56			0.022	
E	7.37		8.38	0.290		0.330
e		1.27			0.050	
e3		5.08			0.200	
F		0.38			0.015	
G			0.101			0.004
M		1.27			0.050	
M1		1.14			0.045	

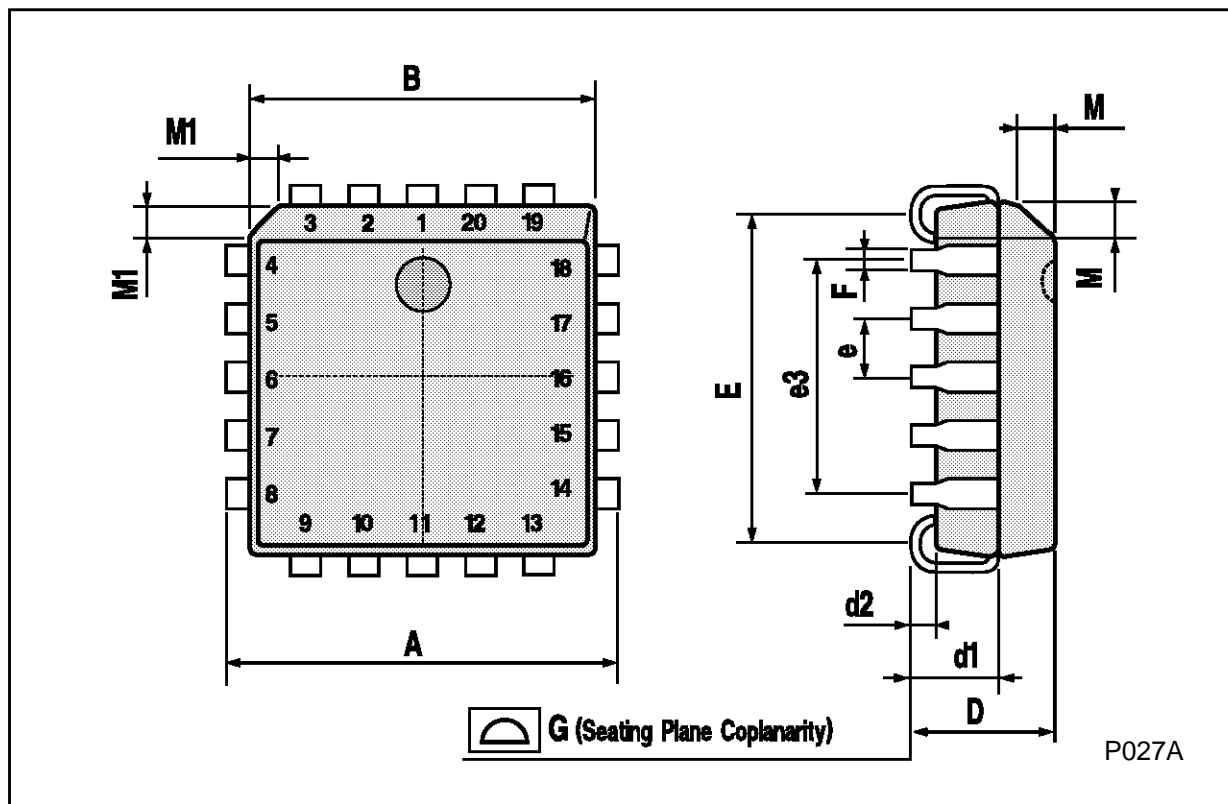

Information furnished is believed to be accurate and reliable. However, SGS-THOMSON Microelectronics assumes no responsibility for the consequences of use of such information nor for any infringement of patents or other rights of third parties which may result from its use. No license is granted by implication or otherwise under any patent or patent rights of SGS-THOMSON Microelectronics. Specifications mentioned in this publication are subject to change without notice. This publication supersedes and replaces all information previously supplied. SGS-THOMSON Microelectronics products are not authorized for use as critical components in life support devices or systems without express written approval of SGS-THOMSON Microelectronics.

© 1994 SGS-THOMSON Microelectronics - All Rights Reserved

SGS-THOMSON Microelectronics GROUP OF COMPANIES
Australia - Brazil - France - Germany - Hong Kong - Italy - Japan - Korea - Malaysia - Malta - Morocco - The Netherlands -
Singapore - Spain - Sweden - Switzerland - Taiwan - Thailand - United Kingdom - U.S.A