

3 TO 8 LINE DECODER/LATCH (INVERTING)

- HIGH SPEED
 $t_{PD} = 17 \text{ ns (TYP.) AT } V_{CC} = 5 \text{ V}$
- LOW POWER DISSIPATION
 $I_{CC} = 4 \mu\text{A (MAX.) AT } T_A = 25 \text{ }^\circ\text{C}$
- COMPATIBLE WITH TTL OUTPUTS
 $V_{IH} = 2 \text{ V (MIN.) } V_{IL} = 0.8 \text{ V (MAX)}$
- OUTPUT DRIVE CAPABILITY
 10 LSTTL LOADS
- SYMMETRICAL OUTPUT IMPEDANCE
 $|I_{OH}| = I_{OL} = 4 \text{ mA (MIN.)}$
- BALANCED PROPAGATION DELAYS
 $t_{PLH} = t_{PHL}$
- PIN AND FUNCTION COMPATIBLE
 WITH 54/74LS137

DESCRIPTION

The M54/74HCT137 is a high speed CMOS 3 TO 8 LINE DECODER/LATCH (INVERTING) fabricated in silicon gate C²MOS technology. It has the same high speed performance of LSTTL combined with true CMOS low power consumption. This device is a 3 to 8 line decoder with latches on the three address inputs. When \overline{GL} goes from low to high, the address present at the select inputs (A, B and C) is stored in the latches. As long as \overline{GL} remains high no address changes will be recognized. Output enable pins G1 and $\overline{G2}$ control the state of the outputs independently of the select or latch-enable inputs. All the outputs are high unless G1 is high and $\overline{G2}$ is low. The HC137 is ideally suited for the implementation of glitch-free decoders in stored-address applications in bus oriented systems. All inputs are equipped with protection circuits against static discharge and transient excess voltage. This integrated circuit has input and output characteristics that are fully compatible with 54/74 LSTTL logic families. M54/74HCT devices are designed to directly interface HSC²MOS systems with TTL and NMOS components. They are also plug in replacements for LSTTL devices giving a reduction of power consumption.

INPUT AND OUTPUT EQUIVALENT CIRCUIT

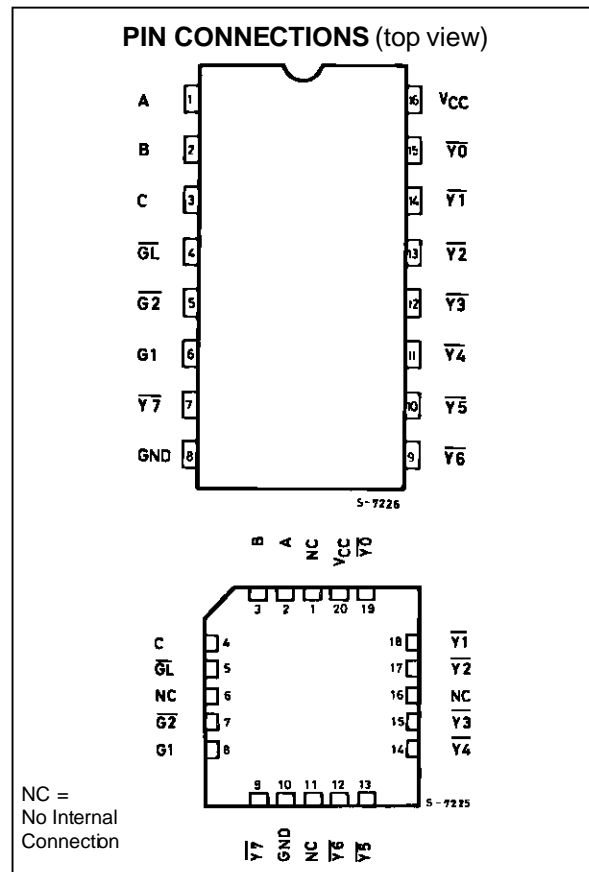
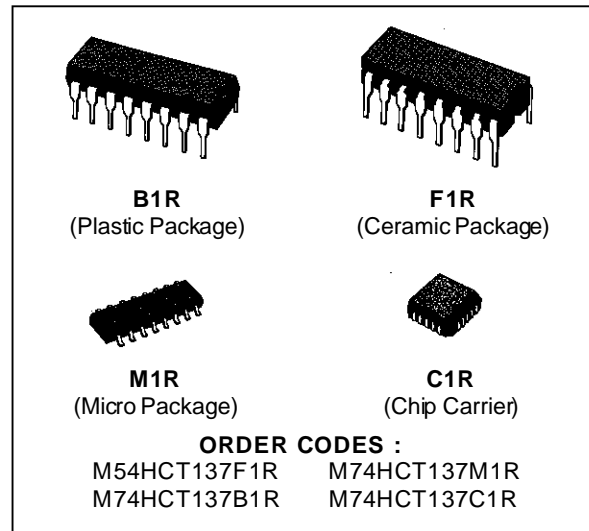
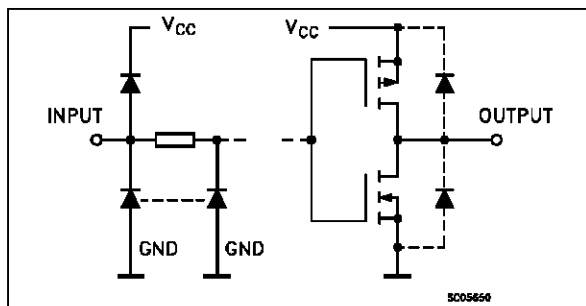

M54/M74HCT137

TRUTH TABLE

INPUTS						OUTPUTS							
ENABLE			SELECT										
$\overline{G1}$	G1	$\overline{G2}$	C	B	A	$\overline{Y0}$	$\overline{Y1}$	$\overline{Y2}$	$\overline{Y3}$	$\overline{Y4}$	$\overline{Y5}$	$\overline{Y6}$	$\overline{Y7}$
X	L	X	X	X	X	H	H	H	H	H	H	H	H
X	X	H	X	X	X	H	H	H	H	H	H	H	H
L	H	L	L	L	L	L	H	H	H	H	H	H	H
L	H	L	L	L	H	H	L	H	H	H	H	H	H
L	H	L	L	H	L	H	H	L	H	H	H	H	H
L	H	L	L	H	H	H	H	H	L	H	H	H	H
L	H	L	H	L	L	H	H	H	H	L	H	H	H
L	H	L	H	L	H	H	H	H	H	H	L	H	H
L	H	L	H	H	L	H	H	H	H	H	H	L	H
L	H	L	H	H	H	H	H	H	H	H	H	H	L
H	H	L	X	X	X	Outputs corresponding to stored address L: all others H							

LOGIC DIAGRAM

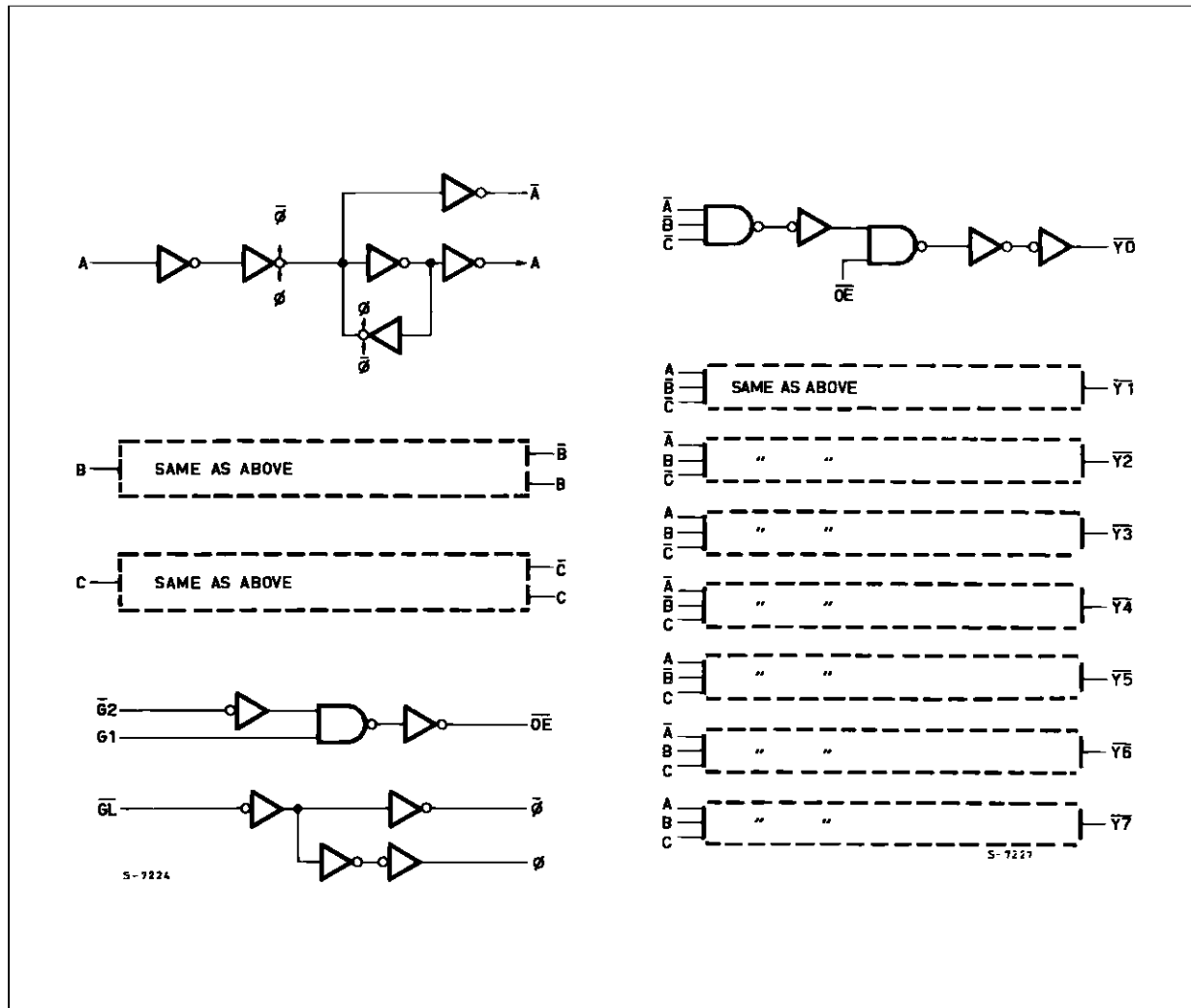

PIN DESCRIPTION

PIN No	SYMBOL	NAME AND FUNCTION
1, 2, 3	A to C	Data Inputs
4	\overline{GL}	Latch Enable Input (Active LOW)
5	$\overline{G2}$	Data Enable Input (Active LOW)
6	G1	Data Enable Input (Active HIGH)
15, 14, 13, 12, 11, 10, 9, 7	$\overline{Y0}$ to $\overline{Y7}$	Multiplexer Outputs
8	GND	Ground (0V)
16	V _{CC}	Positive Supply Voltage

IEC LOGIC SYMBOLS

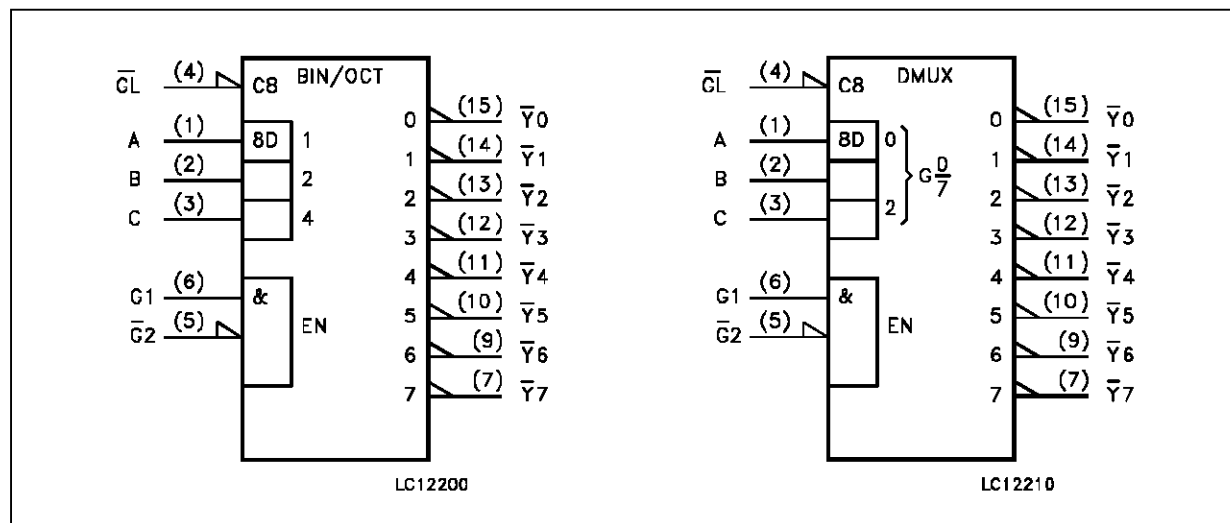

ABSOLUTE MAXIMUM RATINGS

Symbol	Parameter	Value	Unit
V _{CC}	Supply Voltage	-0.5 to +7	V
V _I	DC Input Voltage	-0.5 to V _{CC} + 0.5	V
V _O	DC Output Voltage	-0.5 to V _{CC} + 0.5	V
I _{IK}	DC Input Diode Current	± 20	mA
I _{OK}	DC Output Diode Current	± 20	mA
I _O	DC Output Source Sink Current Per Output Pin	± 25	mA
I _{CC} or I _{GND}	DC V _{CC} or Ground Current	± 50	mA
P _D	Power Dissipation	500 (*)	mW
T _{stg}	Storage Temperature	-65 to +150	°C
T _L	Lead Temperature (10 sec)	300	°C

Absolute Maximum Ratings are those values beyond which damage to the device may occur. Functional operation under these condition is not implied.

(*) 500 mW: ≡ 65 °C derate to 300 mW by 10mW/°C: 65 °C to 85 °C

M54/M74HCT137

RECOMMENDED OPERATING CONDITIONS

Symbol	Parameter	Value	Unit
V_{CC}	Supply Voltage	4.5 to 5.5	V
V_I	Input Voltage	0 to V_{CC}	V
V_O	Output Voltage	0 to V_{CC}	V
T_{op}	Operating Temperature: M54HC Series M74HC Series	-55 to +125 -40 to +85	°C °C
t_r, t_f	Input Rise and Fall Time ($V_{CC} = 4.5$ to $5.5V$)	0 to 500	ns

DC SPECIFICATIONS

Symbol	Parameter	Test Conditions		Value						Unit		
		V_{CC} (V)		$T_A = 25\text{ }^\circ\text{C}$ 54HC and 74HC			-40 to $85\text{ }^\circ\text{C}$ 74HC		-55 to $125\text{ }^\circ\text{C}$ 54HC			
				Min.	Typ.	Max.	Min.	Max.	Min.		Max.	
V_{IH}	High Level Input Voltage	4.5 to 5.5		2.0			2.0		2.0		V	
V_{IL}	Low Level Input Voltage	4.5 to 5.5				0.8		0.8		0.8	V	
V_{OH}	High Level Output Voltage	4.5	$V_I = V_{IH}$ or V_{IL}	$I_O = -20\text{ }\mu\text{A}$	4.4	4.5		4.4		4.4	V	
				$I_O = -4.0\text{ mA}$	4.18	4.31		4.13		4.10		
V_{OL}	Low Level Output Voltage	4.5	$V_I = V_{IH}$ or V_{IL}	$I_O = 20\text{ }\mu\text{A}$		0.0	0.1		0.1		0.1	V
				$I_O = 4.0\text{ mA}$		0.17	0.26		0.33		0.4	
I_I	Input Leakage Current	5.5	$V_I = V_{CC}$ or GND				± 0.1		± 1		± 1	μA
I_{CC}	Quiescent Supply Current	5.5	$V_I = V_{CC}$ or GND				4		40		80	μA
ΔI_{CC}	Additional worst case supply current	5.5	Per Input pin $V_I = 0.5V$ or $V_I = 2.4V$ Other Inputs at V_{CC} or GND $I_O = 0$				2.0		2.9		3.0	mA

AC ELECTRICAL CHARACTERISTICS ($C_L = 50 \text{ pF}$, Input $t_r = t_f = 6 \text{ ns}$)

Symbol	Parameter	Test Conditions		Value						Unit	
		V_{CC} (V)		$T_A = 25 \text{ }^\circ\text{C}$ 54HC and 74HC			$-40 \text{ to } 85 \text{ }^\circ\text{C}$ 74HC		$-55 \text{ to } 125 \text{ }^\circ\text{C}$ 54HC		
				Min.	Typ.	Max.	Min.	Max.	Min.		Max.
t_{TLH} t_{THL}	Output Transition Time	4.5			8	15		19		22	ns
t_{PLH} t_{PHL}	Propagation Delay Time (G1 - \bar{Y})	4.5			17	27		34		41	ns
t_{PLH} t_{PHL}	Propagation Delay Time (G2 - \bar{Y})	4.5			18	28		35		42	ns
t_{PLH} t_{PHL}	Propagation Delay Time (GL - \bar{Y})	4.5			25	39		49		59	ns
t_{PLH} t_{PHL}	Propagation Delay Time (A, B, C - \bar{Y})	4.5			24	37		46		56	ns
$t_{W(L)}$	Minimum Pulse Width (GL)	4.5			8	15		19		22	ns
t_s	Minimum Set-up Time (A, B, C - \bar{GL})	4.5				5		6		8	ns
t_h	Minimum Hold Time (A, B, C - \bar{GL})	4.5				5		6		8	ns
C_{IN}	Input Capacitance				5	10		10		10	pF
$C_{PD} (*)$	Power Dissipation Capacitance				58						pF

(*) C_{PD} is defined as the value of the IC's internal equivalent capacitance which is calculated from the operating current consumption without load. (Refer to Test Circuit). Average operating current can be obtained by the following equation. $I_{CC(opr)} = C_{PD} \cdot V_{CC} \cdot f_{IN} + I_{CC}$

M54/M74HCT137

TEST CIRCUIT I_{cc} (Opr.)

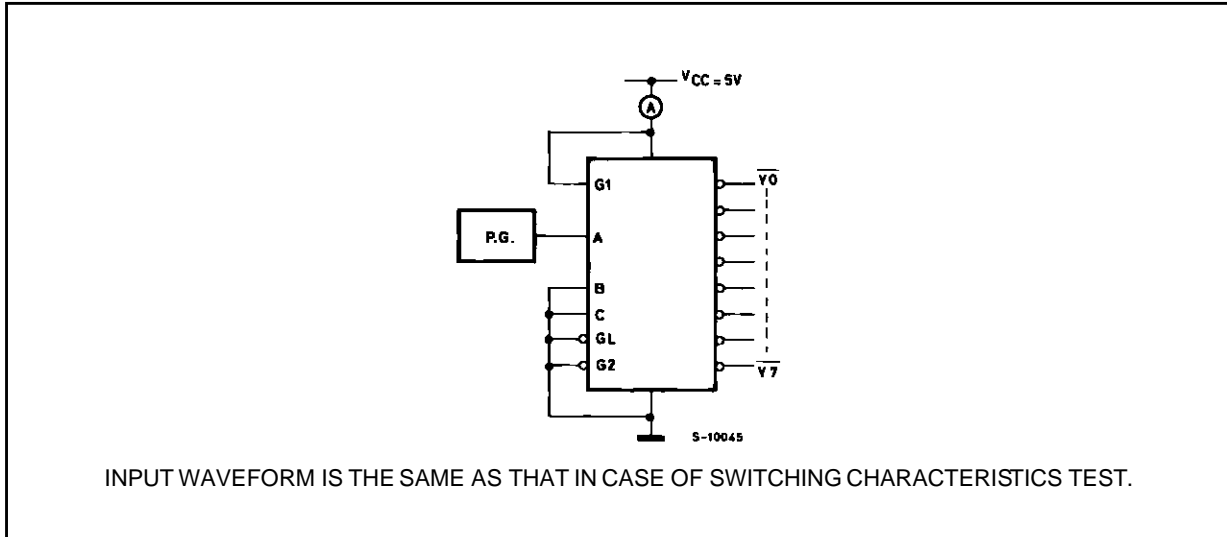

TYPICAL APPLICATION

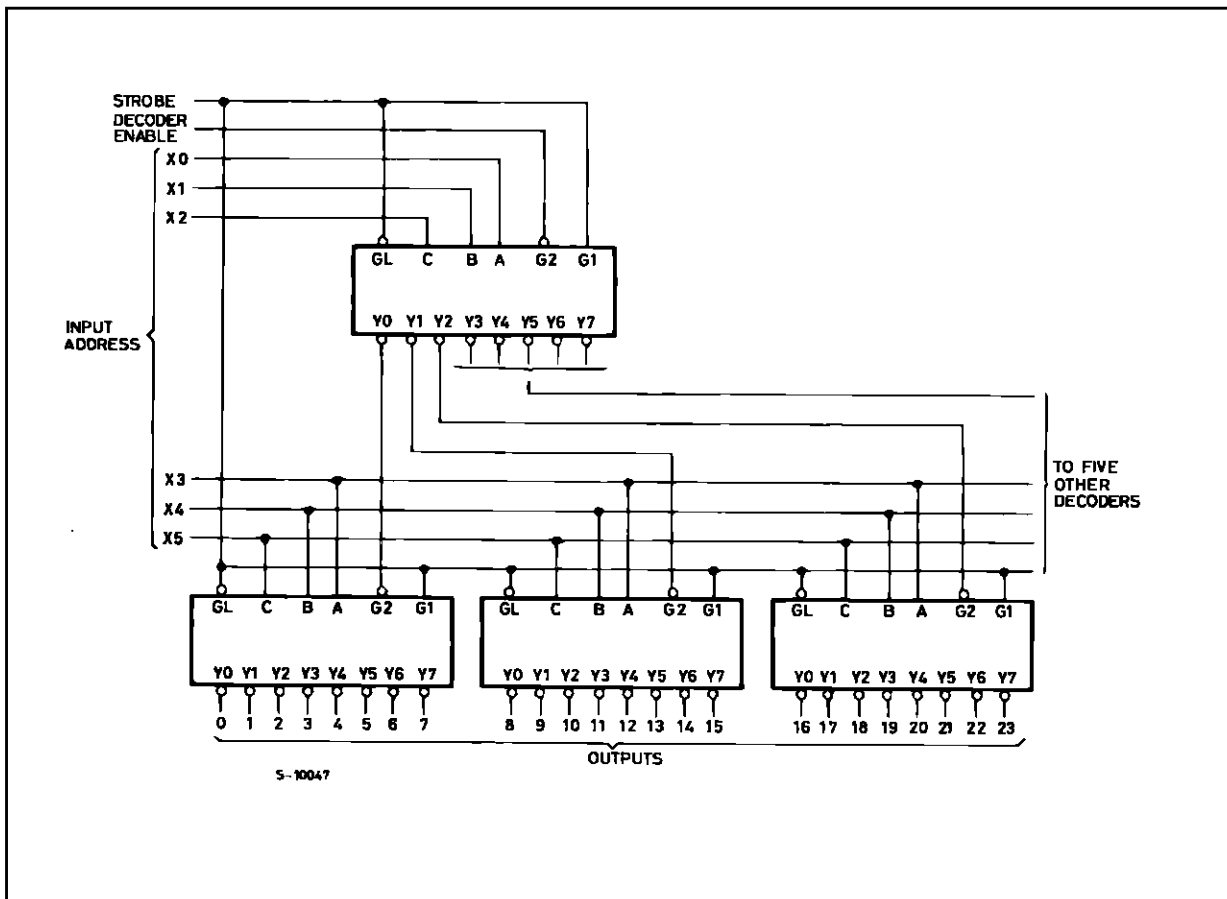

SWITCHING CHARACTERISTICS TEST WAVEFORM

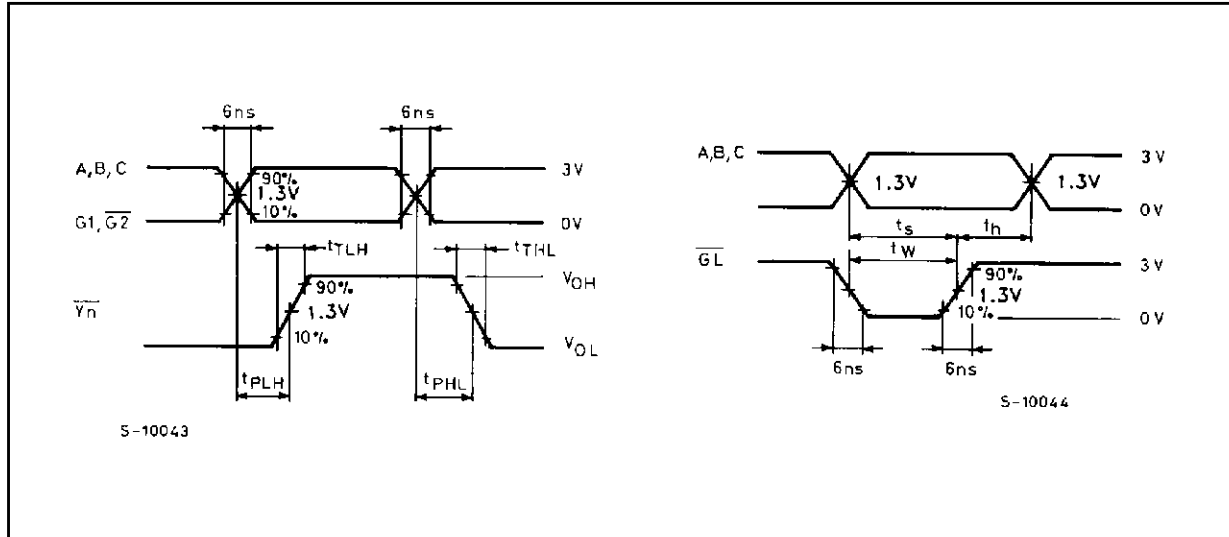

Plastic DIP16 (0.25) MECHANICAL DATA

DIM.	mm			inch		
	MIN.	TYP.	MAX.	MIN.	TYP.	MAX.
a1	0.51			0.020		
B	0.77		1.65	0.030		0.065
b		0.5			0.020	
b1		0.25			0.010	
D			20			0.787
E		8.5			0.335	
e		2.54			0.100	
e3		17.78			0.700	
F			7.1			0.280
I			5.1			0.201
L		3.3			0.130	
Z			1.27			0.050



Ceramic DIP16/1 MECHANICAL DATA

DIM.	mm			inch		
	MIN.	TYP.	MAX.	MIN.	TYP.	MAX.
A			20			0.787
B			7			0.276
D		3.3			0.130	
E	0.38			0.015		
e3		17.78			0.700	
F	2.29		2.79	0.090		0.110
G	0.4		0.55	0.016		0.022
H	1.17		1.52	0.046		0.060
L	0.22		0.31	0.009		0.012
M	0.51		1.27	0.020		0.050
N			10.3			0.406
P	7.8		8.05	0.307		0.317
Q			5.08			0.200

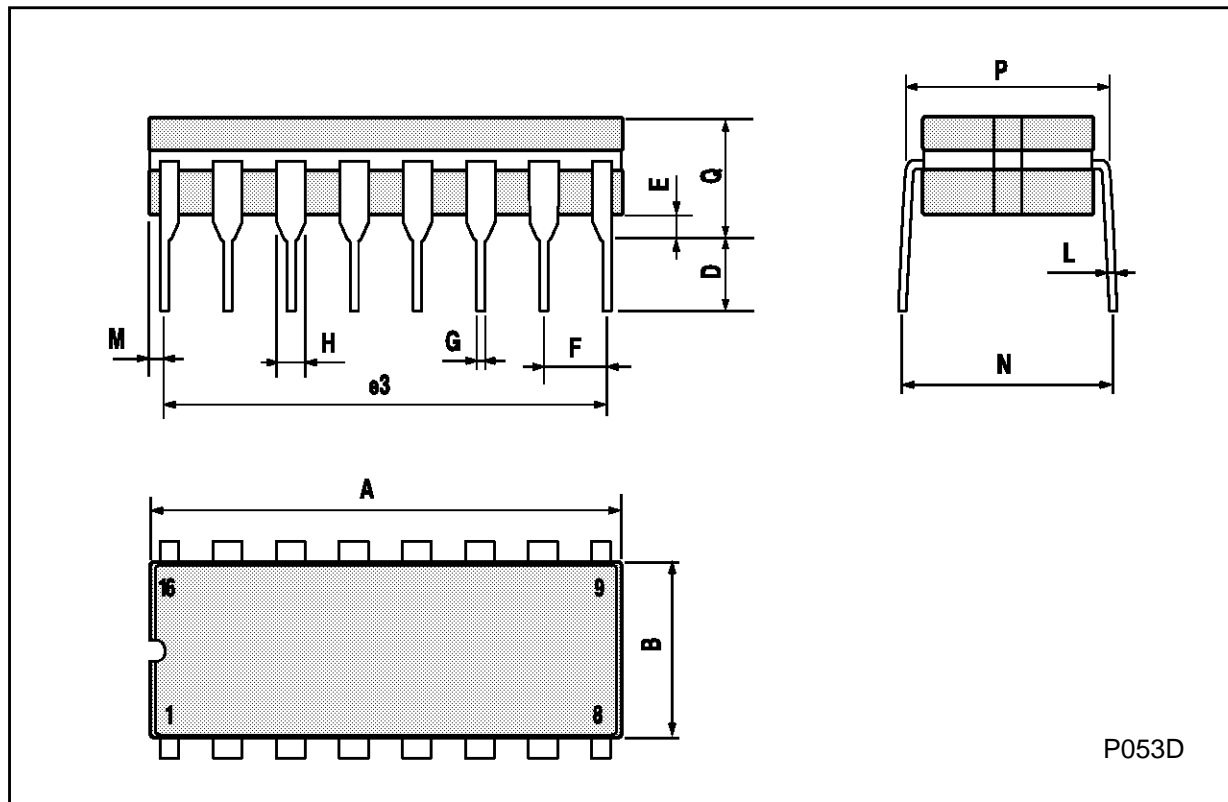

SO16 (Narrow) MECHANICAL DATA

DIM.	mm			inch		
	MIN.	TYP.	MAX.	MIN.	TYP.	MAX.
A			1.75			0.068
a1	0.1		0.2	0.004		0.007
a2			1.65			0.064
b	0.35		0.46	0.013		0.018
b1	0.19		0.25	0.007		0.010
C		0.5			0.019	
c1	45° (typ.)					
D	9.8		10	0.385		0.393
E	5.8		6.2	0.228		0.244
e		1.27			0.050	
e3		8.89			0.350	
F	3.8		4.0	0.149		0.157
G	4.6		5.3	0.181		0.208
L	0.5		1.27	0.019		0.050
M			0.62			0.024
S	8° (max.)					



P013H

PLCC20 MECHANICAL DATA

DIM.	mm			inch		
	MIN.	TYP.	MAX.	MIN.	TYP.	MAX.
A	9.78		10.03	0.385		0.395
B	8.89		9.04	0.350		0.356
D	4.2		4.57	0.165		0.180
d1		2.54			0.100	
d2		0.56			0.022	
E	7.37		8.38	0.290		0.330
e		1.27			0.050	
e3		5.08			0.200	
F		0.38			0.015	
G			0.101			0.004
M		1.27			0.050	
M1		1.14			0.045	



Information furnished is believed to be accurate and reliable. However, SGS-THOMSON Microelectronics assumes no responsibility for the consequences of use of such information nor for any infringement of patents or other rights of third parties which may result from its use. No license is granted by implication or otherwise under any patent or patent rights of SGS-THOMSON Microelectronics. Specifications mentioned in this publication are subject to change without notice. This publication supersedes and replaces all information previously supplied. SGS-THOMSON Microelectronics products are not authorized for use as critical components in life support devices or systems without express written approval of SGS-THOMSON Microelectronics.

© 1994 SGS-THOMSON Microelectronics - All Rights Reserved

SGS-THOMSON Microelectronics GROUP OF COMPANIES
Australia - Brazil - France - Germany - Hong Kong - Italy - Japan - Korea - Malaysia - Malta - Morocco - The Netherlands -
Singapore - Spain - Sweden - Switzerland - Taiwan - Thailand - United Kingdom - U.S.A