

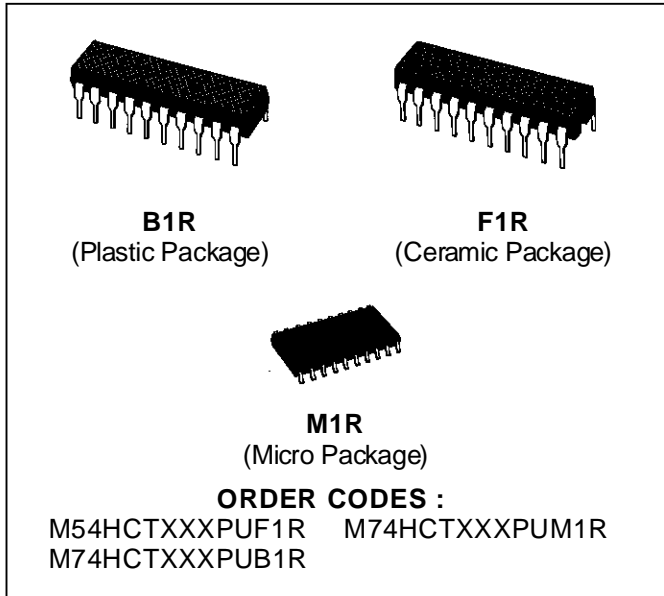

# SGS-THOMSON MICROELECTRONICS M54HCT240/241/244PU M74HCT240/241/244PU

## OCTAL BUS BUFFERS WITH PULL-UP INPUT NETWORK

- HIGH SPEED  
 $t_{PD} = 14 \text{ ns (TYP.) at } V_{CC} = 5\text{V}$
- LOW POWER DISSIPATION  
 $I_{CCH} = 200 \mu\text{A (TYP.) at } T_A = 25 \text{ }^\circ\text{C}$
- COMPATIBLE WITH TTL OUTPUTS  
 $V_{IH} = 2\text{V (MIN.) } V_{IL} = 0.8\text{V (MAX)}$
- CURRENT SOURCES ON DATA INPUTS  
ELIMINATE THE NEED OF EXTERNAL PULL-UP RESISTORS
- OUTPUT DRIVE CAPABILITY  
15 LSTTL LOADS
- SYMMETRICAL OUTPUT IMPEDANCE  
 $|I_{OH}| = I_{OL} = 6 \text{ mA (MIN)}$
- BALANCED PROPAGATION DELAYS  
 $t_{PLH} = t_{PHL}$
- PIN AND FUNCTION COMPATIBLE  
WITH 54/74LS240/241/244



### DESCRIPTION

The M54/74HCT240PU, HCT241PU and HCT244PU are high speed CMOS OCTAL BUS BUFFERS fabricated in silicon gate C<sup>2</sup>MOS technology.

They have the same high speed performance of their non-PU counterpart, plus a unique input topology which incorporates a constant current source for each data input. This results in a small  $I_{IL}$  (-150  $\mu\text{A}$  Typ.) which can fix any data input in the HIGH Logic Level when it is left floating, thus eliminating the need of external pull-up resistor network.

This feature makes these devices particularly suitable in all applications where a data bus needs to be interfaced to manual controls like: rotary selectors, keyboards, dip-switches, etc. The inputs are compatible with TTL, NMOS and CMOS output voltage levels. They achieve the high speed operation similar to equivalent LSTTL while maintaining the CMOS low power dissipation. All inputs are equipped with protection circuits against static discharge and transient excess voltage.

### PIN CONNECTION (top view)

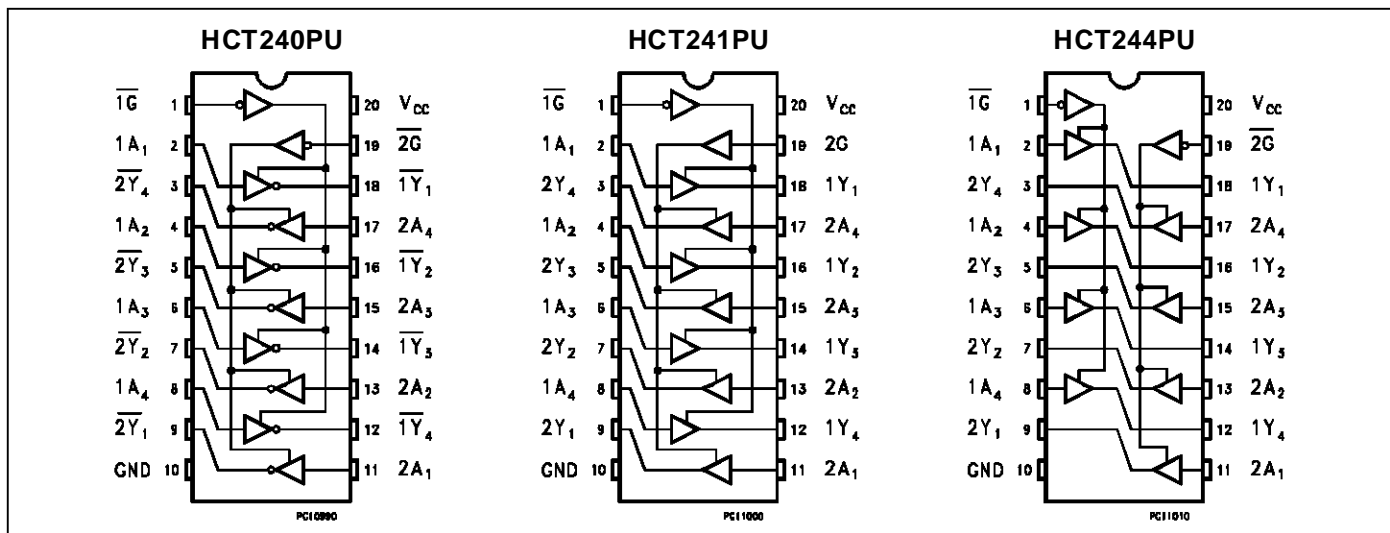

# M54/M74HCT240PU/241PU/244PU

## INPUT AND OUTPUT EQUIVALENT CIRCUIT

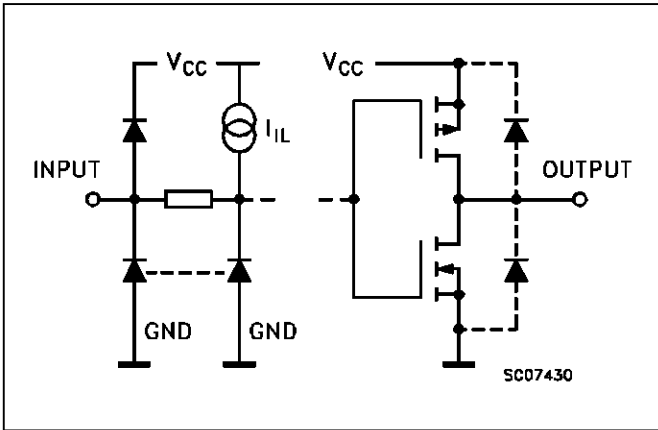

## PIN DESCRIPTION (HCT240PU)

PIN No	SYMBOL	NAME AND FUNCTION
1	$\overline{1G}$	Output Enable Input
2, 4, 6, 8	1A1 to 1A4	Data Inputs
9, 7, 5, 3	$\overline{2Y1}$ to $\overline{2Y4}$	Data Outputs
11, 13, 15, 17	2A1 to 2A4	Data Inputs
18, 16, 14, 12	$\overline{1Y1}$ to $\overline{1Y4}$	Data Outputs
19	$\overline{2G}$	Output Enabel Input
10	GND	Ground (0V)
20	Vcc	Positive Supply Voltage

## PIN DESCRIPTION (HCT241PU)

PIN No	SYMBOL	NAME AND FUNCTION
1	$\overline{1G}$	Output Enable Input
2, 4, 6, 8	1A1 to 1A4	Data Inputs
9, 7, 5, 3	2Y1 to 2Y4	Data Outputs
11, 13, 15, 17	2A1 to 2A4	Data Inputs
18, 16, 14, 12	1Y1 to 1Y4	Data Outputs
19	2G	Output Enabel Input
10	GND	Ground (0V)
20	Vcc	Positive Supply Voltage

## PIN DESCRIPTION (HCT244PU)

PIN No	SYMBOL	NAME AND FUNCTION
1	$\overline{1G}$	Output Enable Input
2, 4, 6, 8	1A1 to 1A4	Data Inputs
9, 7, 5, 3	2Y1 to 2Y4	Data Outputs
11, 13, 15, 17	2A1 to 2A4	Data Inputs
18, 16, 14, 12	1Y1 to 1Y4	Data Outputs
19	$\overline{2G}$	Output Enabel Input
10	GND	Ground (0V)
20	Vcc	Positive Supply Voltage

## IEC LOGIC SYMBOLS

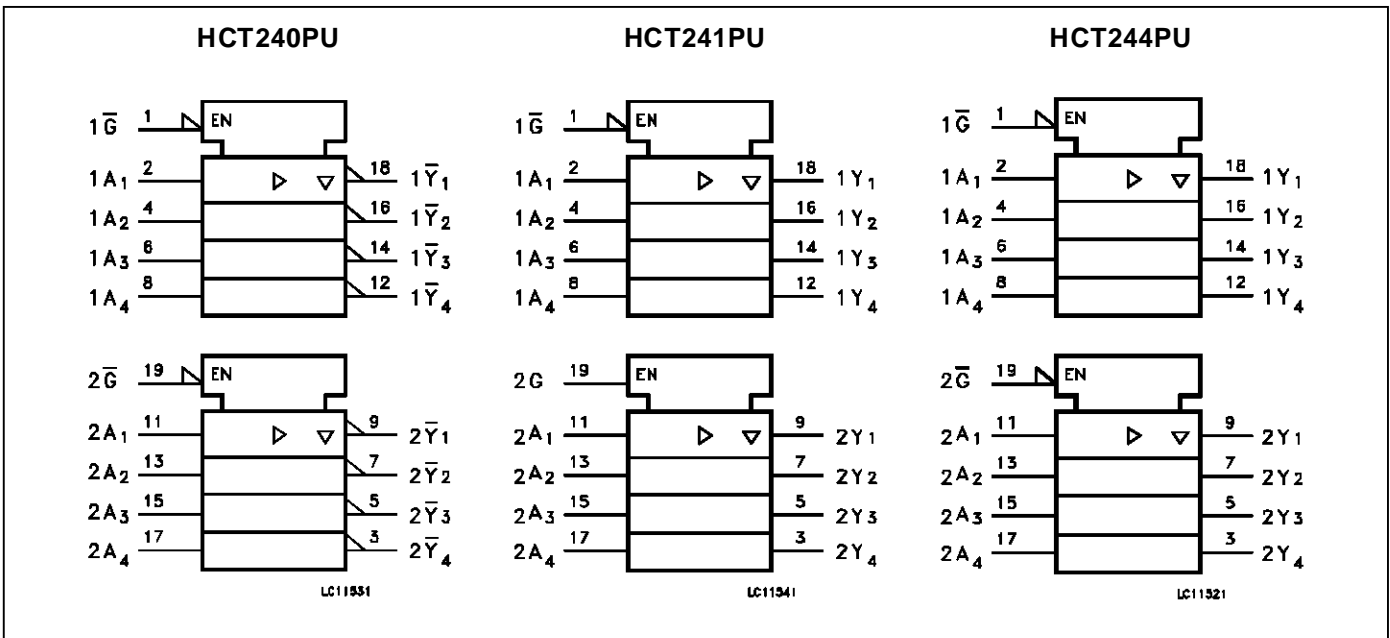

**TRUTH TABLE**

INPUT			OUTPUT		
$\overline{G}$	G (HCT241PU)	An	$\overline{Yn}$ (HCT240PU)	Yn (HCT241PU)	Yn (HCT244PU)
L	H	L	H	L	L
L	H	H	L	H	H
H	L	X	Z	Z	Z

X: "H" or "L"  
Z: High impedance

**CIRCUIT SCHEMATIC (1/8 PACKAGE)**

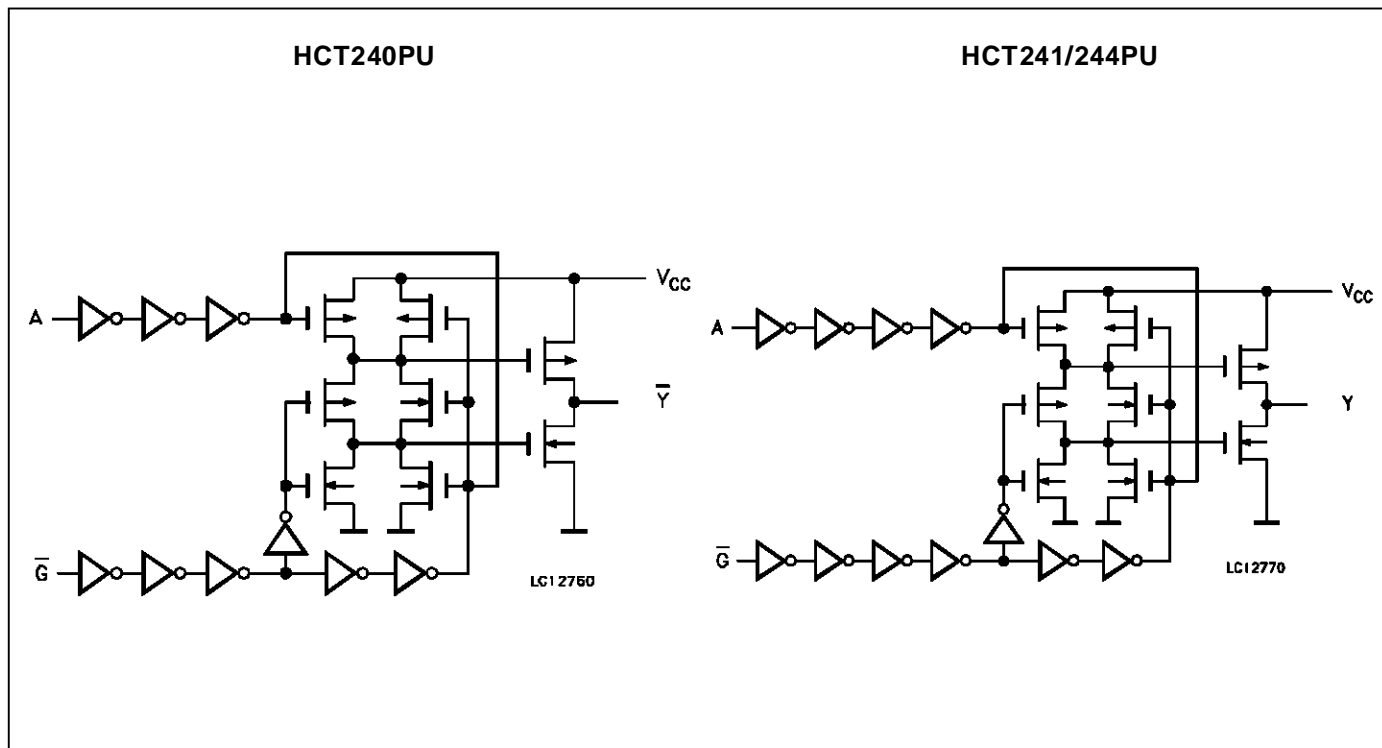

**ABSOLUTE MAXIMUM RATINGS**

Symbol	Parameter	Value	Unit
$V_{CC}$	Supply Voltage	-0.5 to +7	V
$V_I$	DC Input Voltage	-0.5 to $V_{CC} + 0.5$	V
$V_O$	DC Output Voltage	-0.5 to $V_{CC} + 0.5$	V
$I_{IK}$	DC Input Diode Current	$\pm 20$	mA
$I_{OK}$	DC Output Diode Current	$\pm 20$	mA
$I_O$	DC Output Source Sink Current Per Output Pin	$\pm 35$	mA
$I_{CC}$ or $I_{GND}$	DC $V_{CC}$ or Ground Current	$\pm 70$	mA
$P_D$	Power Dissipation	500 (*)	mW
$T_{stg}$	Storage Temperature	-65 to +150	$^{\circ}C$
$T_L$	Lead Temperature (10 sec)	300	$^{\circ}C$

Absolute Maximum Ratings are those values beyond which damage to the device may occur. Functional operation under these condition is not implied.

(\*) 500 mW:  $\cong 65^{\circ}C$  derate to 300 mW by  $10mW/^{\circ}C$ :  $65^{\circ}C$  to  $85^{\circ}C$

**RECOMMENDED OPERATING CONDITIONS**

Symbol	Parameter	Value	Unit
$V_{CC}$	Supply Voltage	4.5 to 5.5	V
$V_I$	Input Voltage	0 to $V_{CC}$	V
$V_O$	Output Voltage	0 to $V_{CC}$	V
$T_{op}$	Operating Temperature: <b>M54HC Series</b> <b>M74HC Series</b>	-55 to +125 -40 to +85	°C °C
$t_r, t_f$	Input Rise and Fall Time ( $V_{CC} = 4.5$ to $5.5V$ )	0 to 500	ns

**DC SPECIFICATIONS**

Symbol	Parameter	Test Conditions		Value						Unit		
				$T_A = 25\text{ }^\circ\text{C}$ 54HC and 74HC			$-40$ to $85\text{ }^\circ\text{C}$ 74HC		$-55$ to $125\text{ }^\circ\text{C}$ 54HC			
		$V_{CC}$ (V)		Min.	Typ.	Max.	Min.	Max.	Min.		Max.	
$V_{IH}$	High Level Input Voltage	4.5 to 5.5		2.0			2.0		2.0		V	
$V_{IL}$	Low Level Input Voltage	4.5 to 5.5				0.8		0.8		0.8	V	
$V_{OH}$	High Level Output Voltage	4.5	$V_I = V_{IH}$ or $V_{IL}$	$I_O = -20\text{ }\mu\text{A}$	4.4	4.5		4.4		4.4	V	
				$I_O = -6.0\text{ mA}$	4.18	4.31		4.13		4.10		
$V_{OL}$	Low Level Output Voltage	4.5	$V_I = V_{IH}$ or $V_{IL}$	$I_O = 20\text{ }\mu\text{A}$		0.0	0.1		0.1		0.1	V
				$I_O = 6.0\text{ mA}$		0.17	0.26		0.33		0.4	
$I_{IL}$	Input Low Current	4.5	$V_I = 0.4\text{ V}$	-50	-130	-250	-30	-350	-20	-400	mA	
		5.5		-50	-180	-300	-30	-400	-20	-450		
$I_{IN}$	input Leakage Current (EN inp.)	5.5	$V_{IN} = V_{CC}$ or GND			$\pm 0.1$		$\pm 1.0$		$\pm 1.0$	$\mu\text{A}$	
$I_{OZ}$	3 State Output Off State Current	5.5	$V_{IN} = V_{IH}$ or $V_{IL}$ $V_O = V_{CC}$ or GND			$\pm 0.5$		$\pm 5.0$		$\pm 10$	$\mu\text{A}$	
$I_{CCH}$	Quiescent Supply Current	5.5	$V_I = V_{CC}$		200	600		800		1000	$\mu\text{A}$	
$\Delta I_{CC}$	Additional worst case supply current	5.5	Per Input pin $V_I = 0.5V$ or $2.4V$ Other Inputs at $V_{CC}$ or GND			3.0		3.9		4.0	mA	

AC ELECTRICAL CHARACTERISTICS (Input  $t_r = t_f = 6$  ns)

Symbol	Parameter	Test Conditions			Value						Unit	
		$V_{CC}$ (V)	$C_L$ (pF)		$T_A = 25\text{ }^\circ\text{C}$ 54HC and 74HC			$-40\text{ to }85\text{ }^\circ\text{C}$ 74HC		$-55\text{ to }125\text{ }^\circ\text{C}$ 54HC		
					Min.	Typ.	Max.	Min.	Max.	Min.		Max.
$t_{TLH}$ $t_{THL}$	Output Transition Time	4.5	50			7	12		15		18	ns
$t_{PLH}$ $t_{PHL}$	Propagation Delay Time (for 240)	4.5	50			18	28		35		42	ns
		4.5	150			22	34		43		51	ns
$t_{PLH}$ $t_{PHL}$	Propagation Delay Time (for 241/244)	4.5	50			20	31		39		47	ns
		4.5	150			24	37		46		56	ns
$t_{PZL}$ $t_{PZH}$	Output Enable Time	4.5	50	$R_L = 1K\Omega$		22	34		43		51	ns
		4.5	150	$R_L = 1K\Omega$		26	40		50		60	ns
$t_{PLZ}$ $t_{PHZ}$	Output Disable Time	4.5	50	$R_L = 1K\Omega$		25	36		45		54	ns
$C_{IN}$	Input Capacitance					5	10		10		10	pF
$C_{PD} (*)$	Power Dissipation Capacitance					100						pF

TEST CIRCUIT  $I_{CC}$  (Opr.)

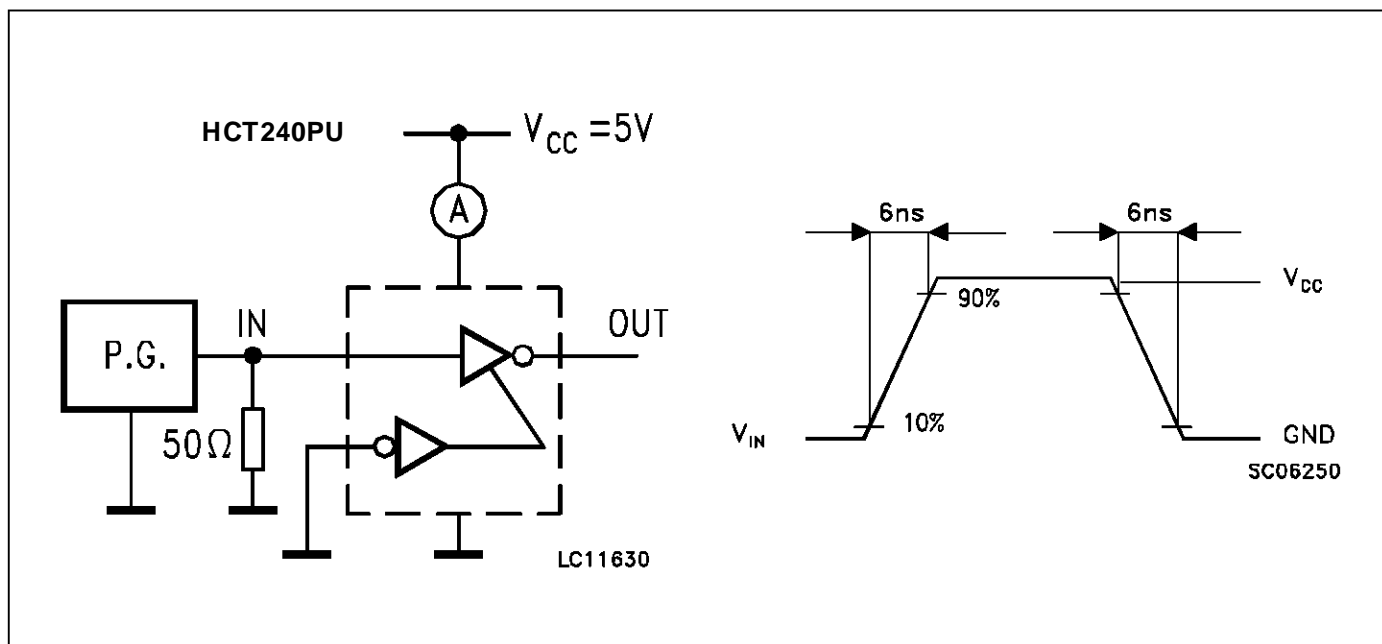

SWITCHING CHARACTERISTICS TEST WAVEFORM

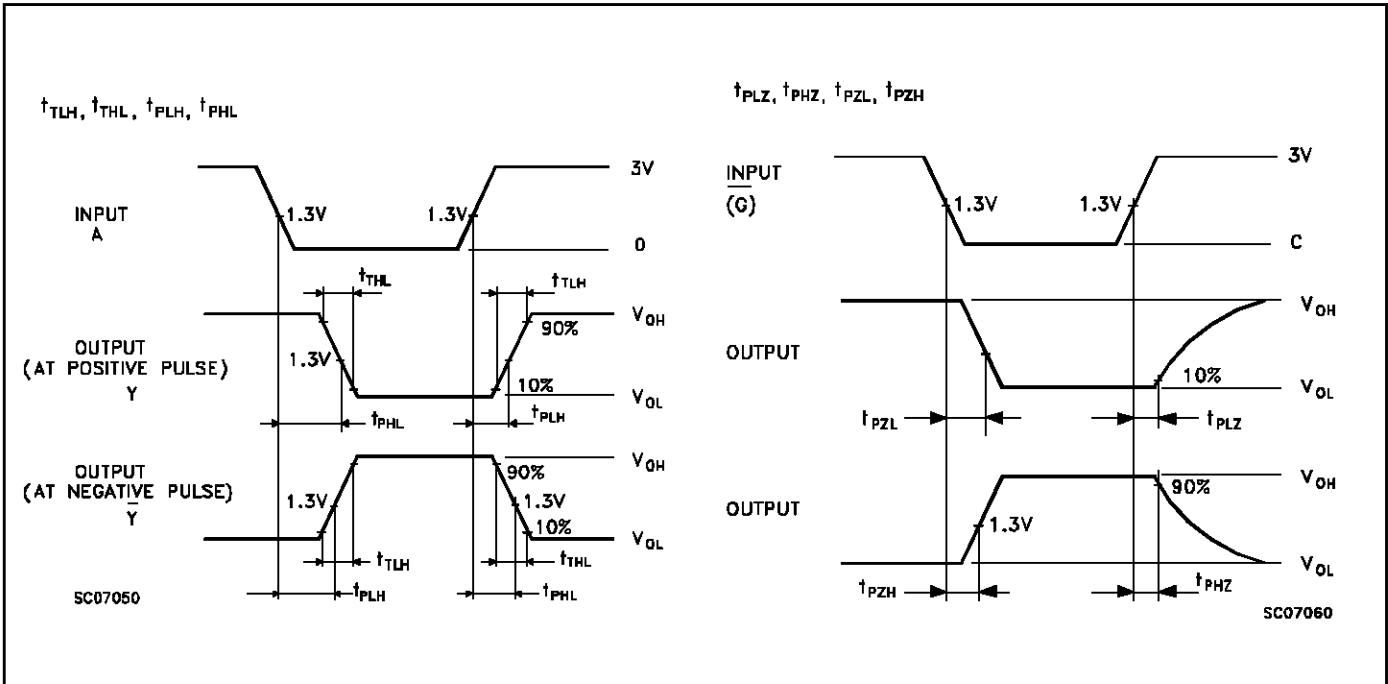

## Plastic DIP20 (0.25) MECHANICAL DATA

DIM.	mm			inch		
	MIN.	TYP.	MAX.	MIN.	TYP.	MAX.
a1	0.254			0.010		
B	1.39		1.65	0.055		0.065
b		0.45			0.018	
b1		0.25			0.010	
D			25.4			1.000
E		8.5			0.335	
e		2.54			0.100	
e3		22.86			0.900	
F			7.1			0.280
I			3.93			0.155
L		3.3			0.130	
Z			1.34			0.053

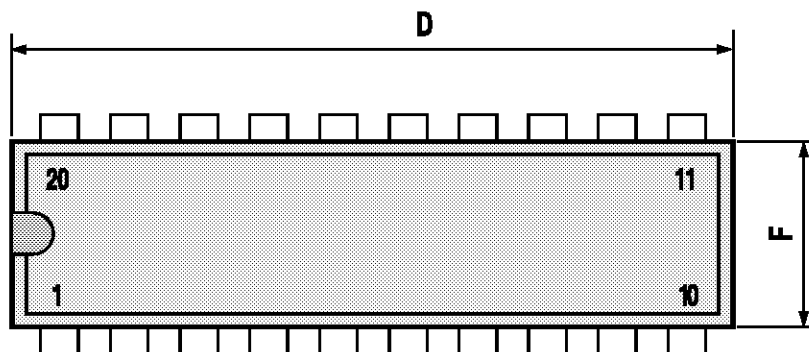
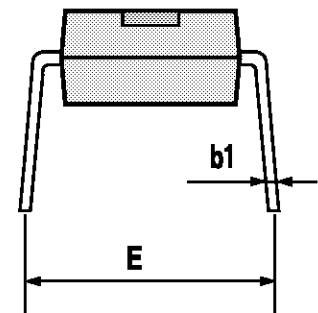
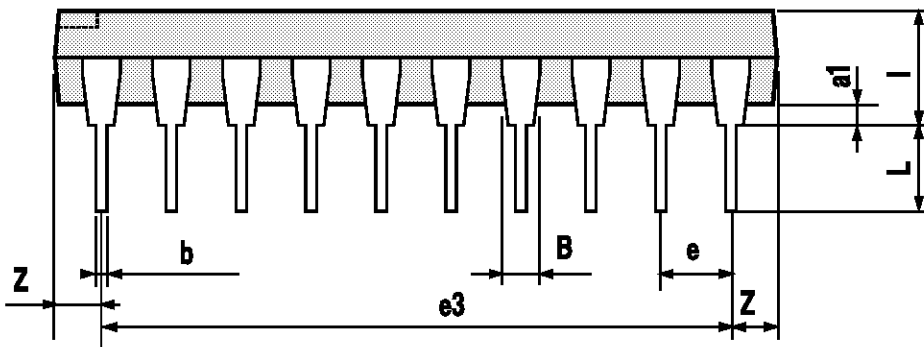

**Ceramic DIP20 MECHANICAL DATA**

DIM.	mm			inch		
	MIN.	TYP.	MAX.	MIN.	TYP.	MAX.
A			25			0.984
B			7.8			0.307
D		3.3			0.130	
E	0.5		1.78	0.020		0.070
e3		22.86			0.900	
F	2.29		2.79	0.090		0.110
G	0.4		0.55	0.016		0.022
I	1.27		1.52	0.050		0.060
L	0.22		0.31	0.009		0.012
M	0.51		1.27	0.020		0.050
N1	4° (min.), 15° (max.)					
P	7.9		8.13	0.311		0.320
Q			5.71			0.225

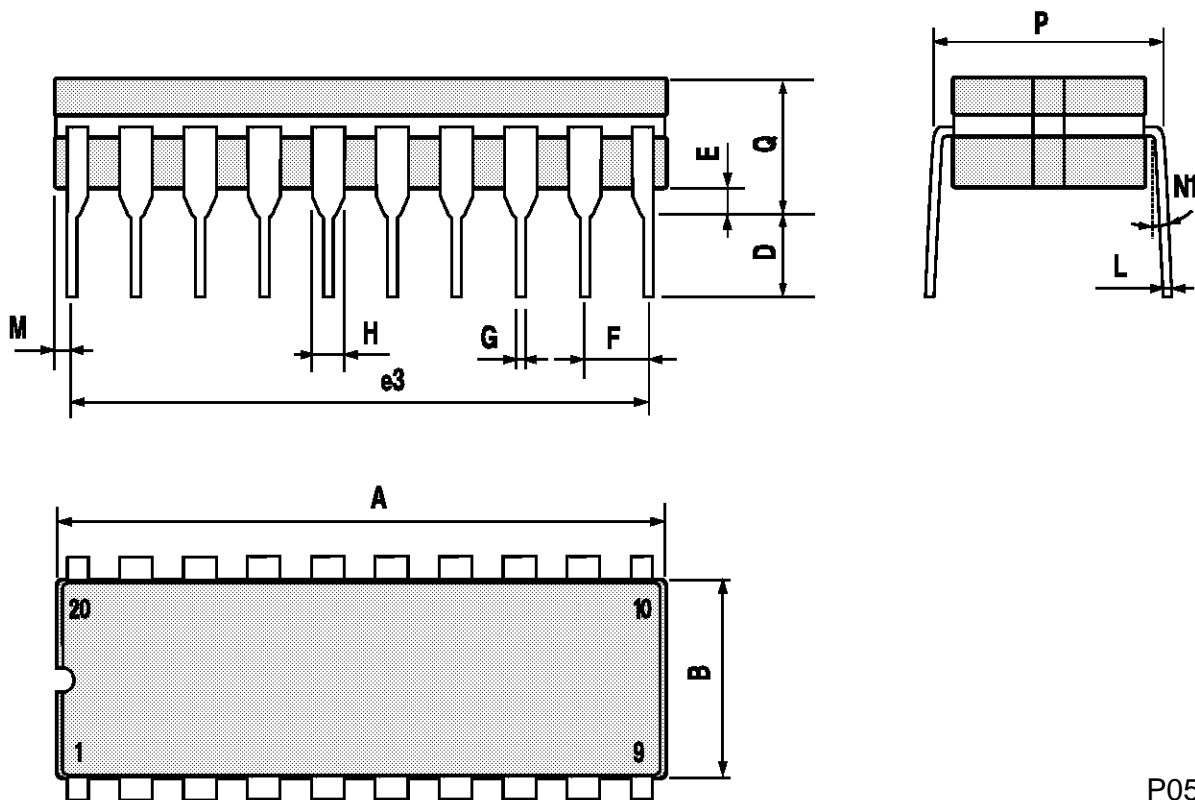

P057H

## SO20 MECHANICAL DATA

DIM.	mm			inch		
	MIN.	TYP.	MAX.	MIN.	TYP.	MAX.
A			2.65			0.104
a1	0.10		0.20	0.004		0.007
a2			2.45			0.096
b	0.35		0.49	0.013		0.019
b1	0.23		0.32	0.009		0.012
C		0.50			0.020	
c1	45° (typ.)					
D	12.60		13.00	0.496		0.512
E	10.00		10.65	0.393		0.419
e		1.27			0.050	
e3		11.43			0.450	
F	7.40		7.60	0.291		0.299
L	0.50		1.27	0.19		0.050
M			0.75			0.029
S	8° (max.)					

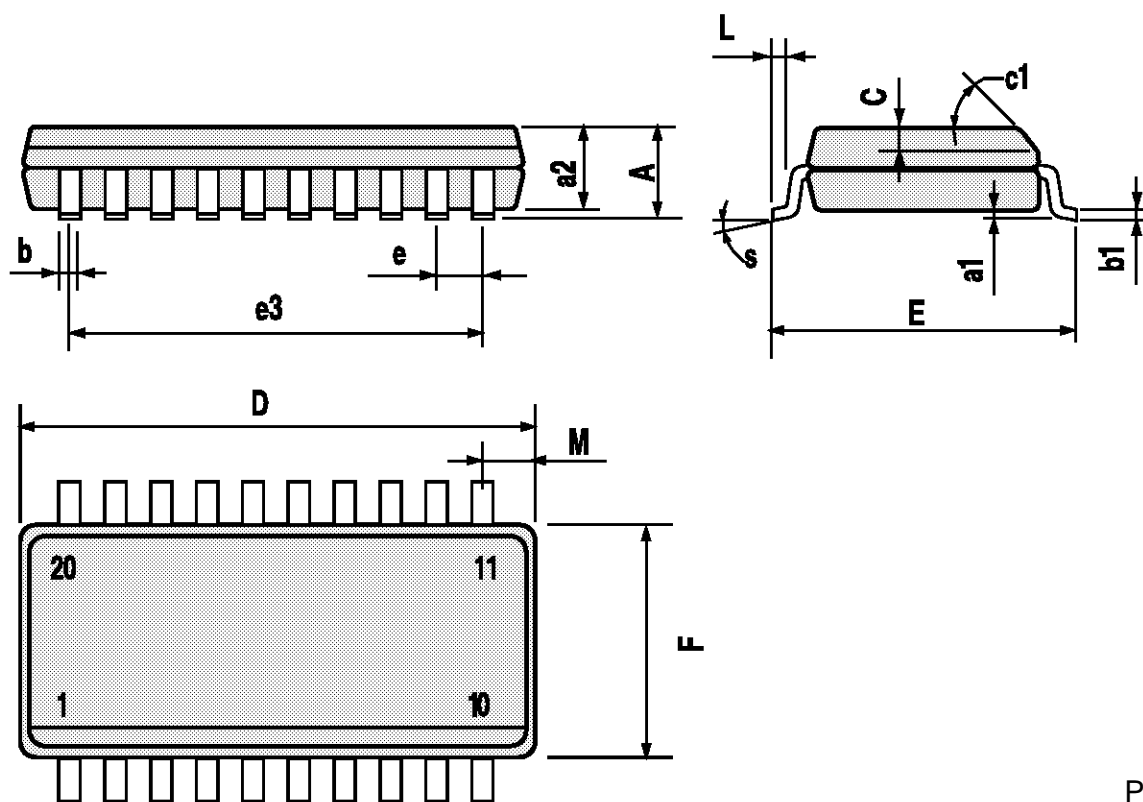

Information furnished is believed to be accurate and reliable. However, SGS-THOMSON Microelectronics assumes no responsibility for the consequences of use of such information nor for any infringement of patents or other rights of third parties which may result from its use. No license is granted by implication or otherwise under any patent or patent rights of SGS-THOMSON Microelectronics. Specifications mentioned in this publication are subject to change without notice. This publication supersedes and replaces all information previously supplied. SGS-THOMSON Microelectronics products are not authorized for use as critical components in life support devices or systems without express written approval of SGS-THOMSON Microelectronics.

© 1994 SGS-THOMSON Microelectronics - All Rights Reserved

SGS-THOMSON Microelectronics GROUP OF COMPANIES

Australia - Brazil - France - Germany - Hong Kong - Italy - Japan - Korea - Malaysia - Malta - Morocco - The Netherlands - Singapore - Spain - Sweden - Switzerland - Taiwan - Thailand - United Kingdom - U.S.A