

## TRIPLE 3-INPUT NOR GATE

- HIGH SPEED  
 $t_{PD} = 9 \text{ ns}$  (TYP.) AT  $V_{CC} = 5 \text{ V}$
- LOW POWER DISSIPATION  
 $I_{CC} = 1 \mu\text{A}$  (MAX.) AT  $T_A = 25 \text{ }^\circ\text{C}$
- COMPATIBLE WITH TTL OUTPUTS  
 $V_{IH} = 2 \text{ V}$  (MIN.)  $V_{IL} = 0.8 \text{ V}$  (MAX)
- OUTPUT DRIVE CAPABILITY  
 10 LSTTL LOADS
- SYMMETRICAL OUTPUT IMPEDANCE  
 $|I_{OH}| = I_{OL} = 4 \text{ mA}$  (MIN.)
- BALANCED PROPAGATION DELAYS  
 $t_{PLH} = t_{PHL}$
- PIN AND FUNCTION COMPATIBLE WITH  
 54/74LS27

### DESCRIPTION

The M54/74HCT27 is a high speed CMOS TRIPLE 3-INPUT NOR GATE fabricated in silicon gate  $C^2$ MOS technology.

It has the same high speed performance of LSTTL combined with true CMOS low power consumption. The internal circuit is composed of 3 stages including buffered output, which gives high noise immunity and a stable output. All inputs are equipped with protection circuits against static discharge and transient excess voltage. This integrated circuit has input and output characteristics that are fully compatible with 54/74 LSTTL logic families. M54/74HCT devices are designed to directly interface HSC<sup>2</sup>MOS systems with TTL and NMOS components. They are also plug in replacements for LSTTL devices giving a reduction of power consumption.

### INPUT AND OUTPUT EQUIVALENT CIRCUIT

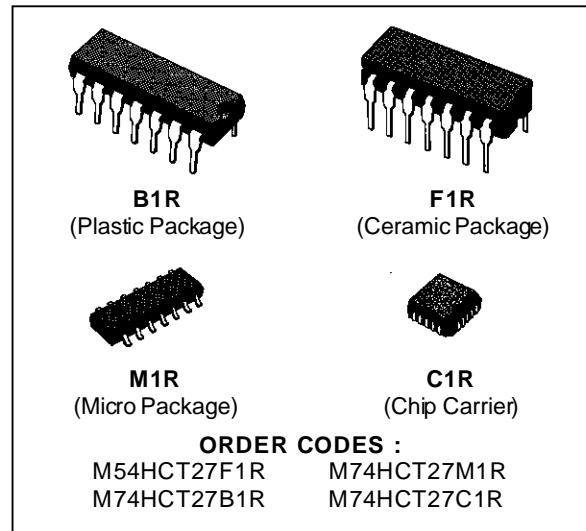
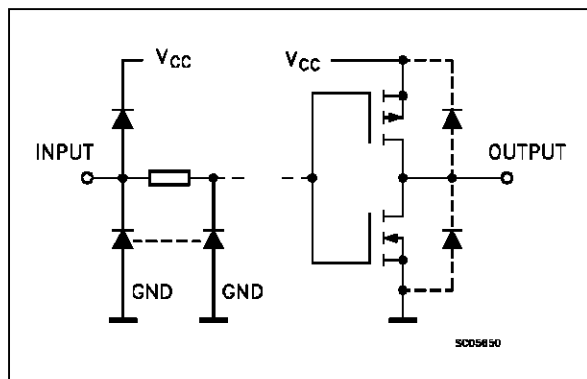

### PIN CONNECTIONS (top view)

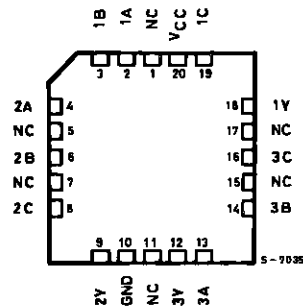
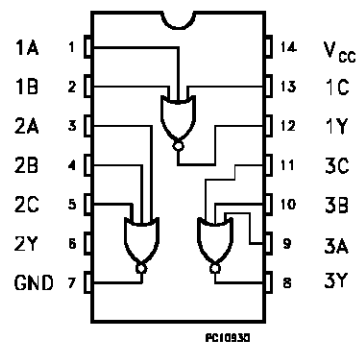

NC =  
No Internal  
Connection

## M54/M74HCT27

### TRUTH TABLE

A	B	C	Y
L	L	L	H
H	X	X	L
X	H	X	L
X	X	H	L

### PIN DESCRIPTION

PIN No	SYMBOL	NAME AND FUNCTION
1, 3, 9	1A to 3A	Data Inputs
2, 4, 10	1B to 3B	Data Inputs
13, 5, 11	1C to 3C	Data Inputs
12, 6, 8	1Y to 3Y	Data Outputs
7	GND	Ground (0V)
14	V <sub>CC</sub>	Positive Supply Voltage

### IEC Logic Symbol

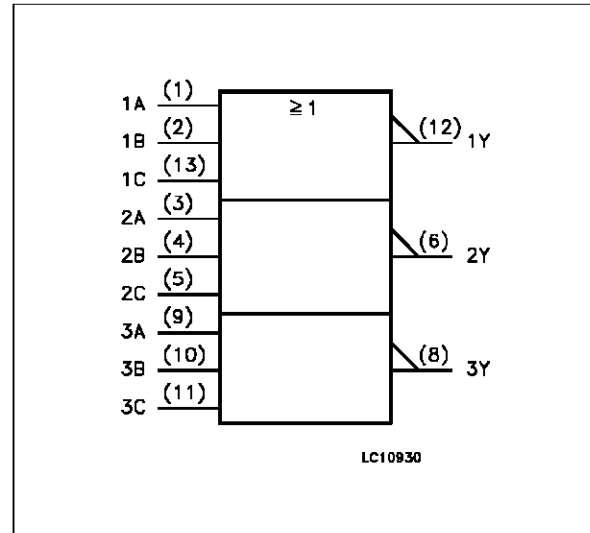

### LOGIC DIAGRAM

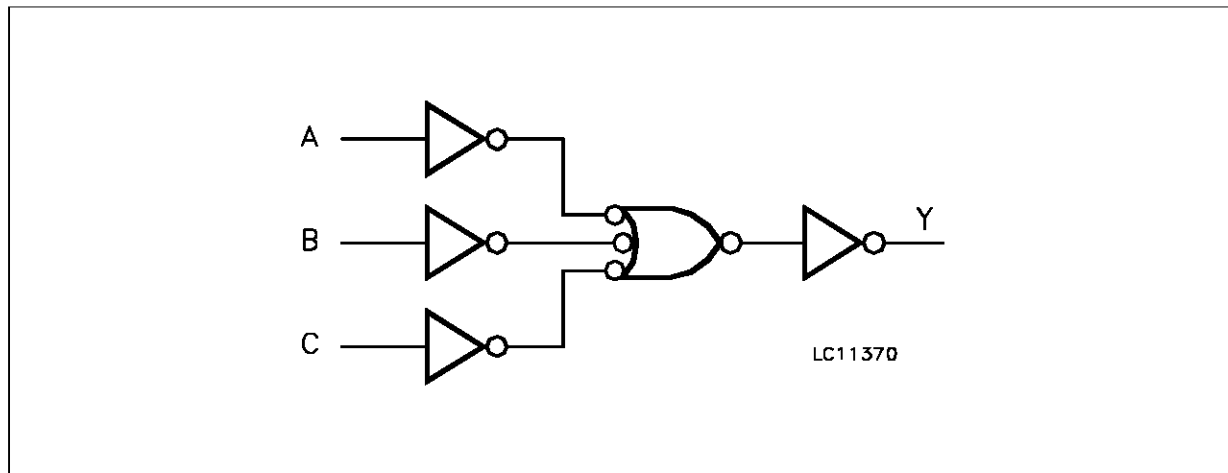

### ABSOLUTE MAXIMUM RATINGS

Symbol	Parameter	Value	Unit
V <sub>CC</sub>	Supply Voltage	-0.5 to +7	V
V <sub>I</sub>	DC Input Voltage	-0.5 to V <sub>CC</sub> + 0.5	V
V <sub>O</sub>	DC Output Voltage	-0.5 to V <sub>CC</sub> + 0.5	V
I <sub>IK</sub>	DC Input Diode Current	± 20	mA
I <sub>OK</sub>	DC Output Diode Current	± 20	mA
I <sub>O</sub>	DC Output Source Sink Current Per Output Pin	± 25	mA
I <sub>CC</sub> or I <sub>GND</sub>	DC V <sub>CC</sub> or Ground Current	± 50	mA
P <sub>D</sub>	Power Dissipation	500 (*)	mW
T <sub>stg</sub>	Storage Temperature	-65 to +150	°C
T <sub>L</sub>	Lead Temperature (10 sec)	300	°C

Absolute Maximum Ratings are those values beyond which damage to the device may occur. Functional operation under these condition is not implied.

(\*) 500 mW: ≅ 65 °C derate to 300 mW by 10mW/°C: 65 °C to 85 °C

## RECOMMENDED OPERATING CONDITIONS

Symbol	Parameter	Value	Unit
$V_{CC}$	Supply Voltage	4.5 to 5.5	V
$V_I$	Input Voltage	0 to $V_{CC}$	V
$V_O$	Output Voltage	0 to $V_{CC}$	V
$T_{op}$	Operating Temperature: <b>M54HC Series</b> <b>M74HC Series</b>	-55 to +125 -40 to +85	°C °C
$t_r, t_f$	Input Rise and Fall Time ( $V_{CC} = 4.5$ to $5.5V$ )	0 to 500	ns

## DC SPECIFICATIONS

Symbol	Parameter	Test Conditions		Value						Unit		
		$V_{CC}$ (V)		$T_A = 25\text{ }^\circ\text{C}$ 54HC and 74HC			$-40$ to $85\text{ }^\circ\text{C}$ 74HC		$-55$ to $125\text{ }^\circ\text{C}$ 54HC			
				Min.	Typ.	Max.	Min.	Max.	Min.		Max.	
$V_{IH}$	High Level Input Voltage	4.5 to 5.5		2.0			2.0		2.0		V	
$V_{IL}$	Low Level Input Voltage	4.5 to 5.5				0.8		0.8		0.8	V	
$V_{OH}$	High Level Output Voltage	4.5	$V_I = V_{IH}$ or $V_{IL}$	$I_O = -20\text{ }\mu\text{A}$	4.4	4.5		4.4		4.4		V
				$I_O = -4.0\text{ mA}$	4.18	4.31		4.13		4.10		
$V_{OL}$	Low Level Output Voltage	4.5	$V_I = V_{IH}$ or $V_{IL}$	$I_O = 20\text{ }\mu\text{A}$		0.0	0.1		0.1		0.1	V
				$I_O = 4.0\text{ mA}$		0.17	0.26		0.33		0.4	
$I_I$	Input Leakage Current	5.5	$V_I = V_{CC}$ or GND				$\pm 0.1$		$\pm 1$		$\pm 1$	$\mu\text{A}$
$I_{CC}$	Quiescent Supply Current	5.5	$V_I = V_{CC}$ or GND				1		10		20	$\mu\text{A}$
$\Delta I_{CC}$	Additional worst case supply current	5.5	Per Input pin $V_I = 0.5V$ or $V_I = 2.4V$ Other Inputs at $V_{CC}$ or GND $I_O = 0$				2.0		2.9		3.0	mA

# M54/M74HCT27

## AC ELECTRICAL CHARACTERISTICS (C<sub>L</sub> = 50 pF, Input t<sub>r</sub> = t<sub>f</sub> = 6 ns)

Symbol	Parameter	Test Conditions		Value						Unit	
		V <sub>CC</sub> (V)		T <sub>A</sub> = 25 °C 54HC and 74HC			-40 to 85 °C 74HC		-55 to 125 °C 54HC		
				Min.	Typ.	Max.	Min.	Max.	Min.		Max.
t <sub>TLH</sub> t <sub>THL</sub>	Output Transition Time	4.5			8	15		19		22	ns
t <sub>PLH</sub> t <sub>PHL</sub>	Propagation Delay Time	4.5			12	19		24		29	ns
C <sub>IN</sub>	Input Capacitance				5	10		10		10	pF
C <sub>PD</sub> (*)	Power Dissipation Capacitance				48						pF

(\*) C<sub>PD</sub> is defined as the value of the IC's internal equivalent capacitance which is calculated from the operating current consumption without load. (Refer to Test Circuit). Average operating current can be obtained by the following equation. I<sub>CC(opr)</sub> = C<sub>PD</sub> • V<sub>CC</sub> • f<sub>IN</sub> + I<sub>CC</sub>/3 (per Gate)

## SWITCHING CHARACTERISTICS TEST CIRCUIT

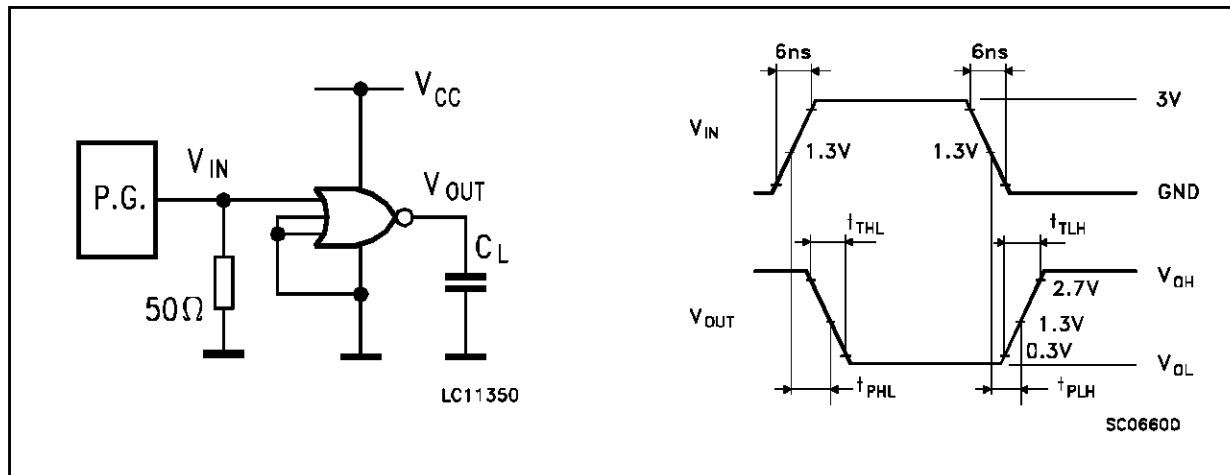

## TEST CIRCUIT I<sub>CC</sub> (Opr.)

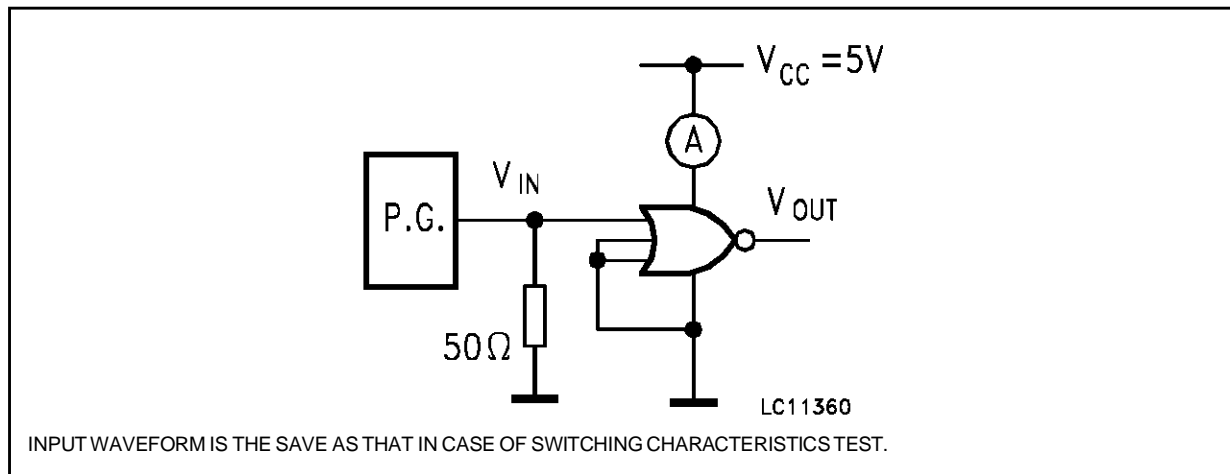

**Plastic DIP14 MECHANICAL DATA**

DIM.	mm			inch		
	MIN.	TYP.	MAX.	MIN.	TYP.	MAX.
a1	0.51			0.020		
B	1.39		1.65	0.055		0.065
b		0.5			0.020	
b1		0.25			0.010	
D			20			0.787
E		8.5			0.335	
e		2.54			0.100	
e3		15.24			0.600	
F			7.1			0.280
I			5.1			0.201
L		3.3			0.130	
Z	1.27		2.54	0.050		0.100

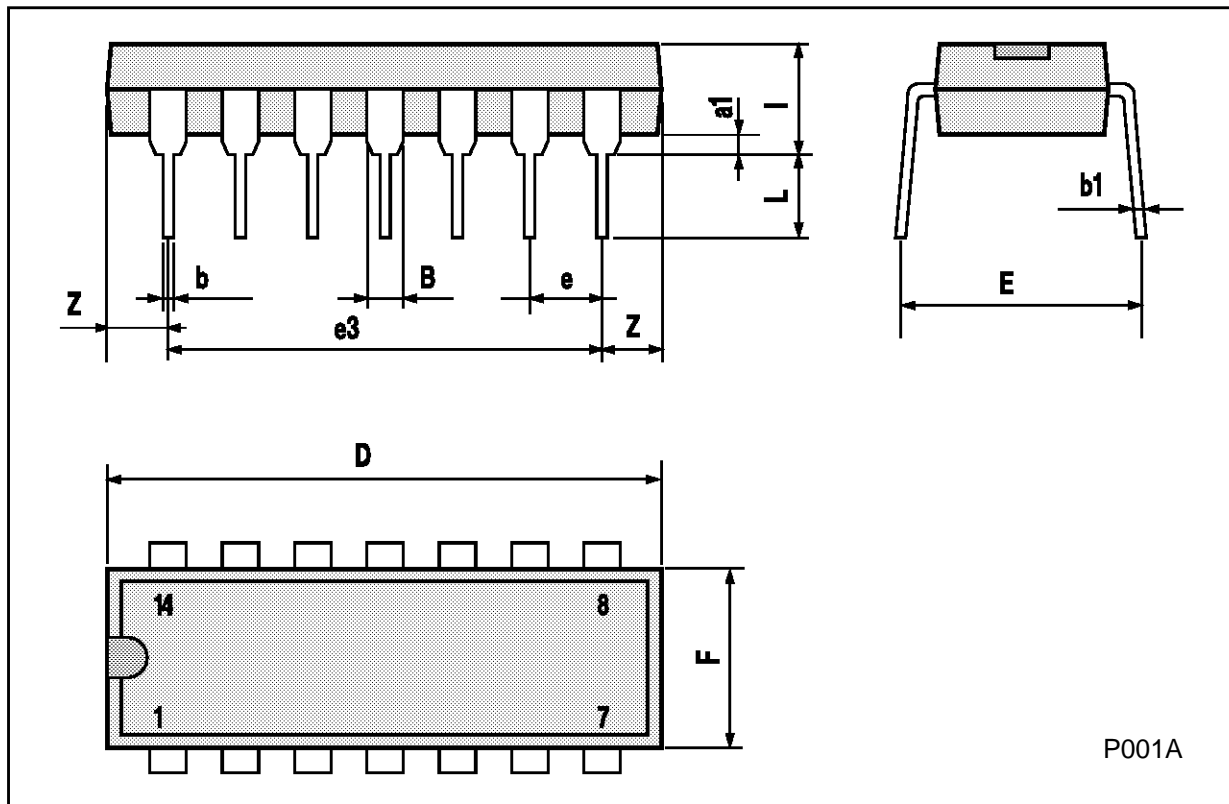

**Ceramic DIP14/1 MECHANICAL DATA**

DIM.	mm			inch		
	MIN.	TYP.	MAX.	MIN.	TYP.	MAX.
A			20			0.787
B			7.0			0.276
D		3.3			0.130	
E	0.38			0.015		
e3		15.24			0.600	
F	2.29		2.79	0.090		0.110
G	0.4		0.55	0.016		0.022
H	1.17		1.52	0.046		0.060
L	0.22		0.31	0.009		0.012
M	1.52		2.54	0.060		0.100
N			10.3			0.406
P	7.8		8.05	0.307		0.317
Q			5.08			0.200



P053C

## SO14 MECHANICAL DATA

DIM.	mm			inch		
	MIN.	TYP.	MAX.	MIN.	TYP.	MAX.
A			1.75			0.068
a1	0.1		0.2	0.003		0.007
a2			1.65			0.064
b	0.35		0.46	0.013		0.018
b1	0.19		0.25	0.007		0.010
C		0.5			0.019	
c1	45° (typ.)					
D	8.55		8.75	0.336		0.344
E	5.8		6.2	0.228		0.244
e		1.27			0.050	
e3		7.62			0.300	
F	3.8		4.0	0.149		0.157
G	4.6		5.3	0.181		0.208
L	0.5		1.27	0.019		0.050
M			0.68			0.026
S	8° (max.)					

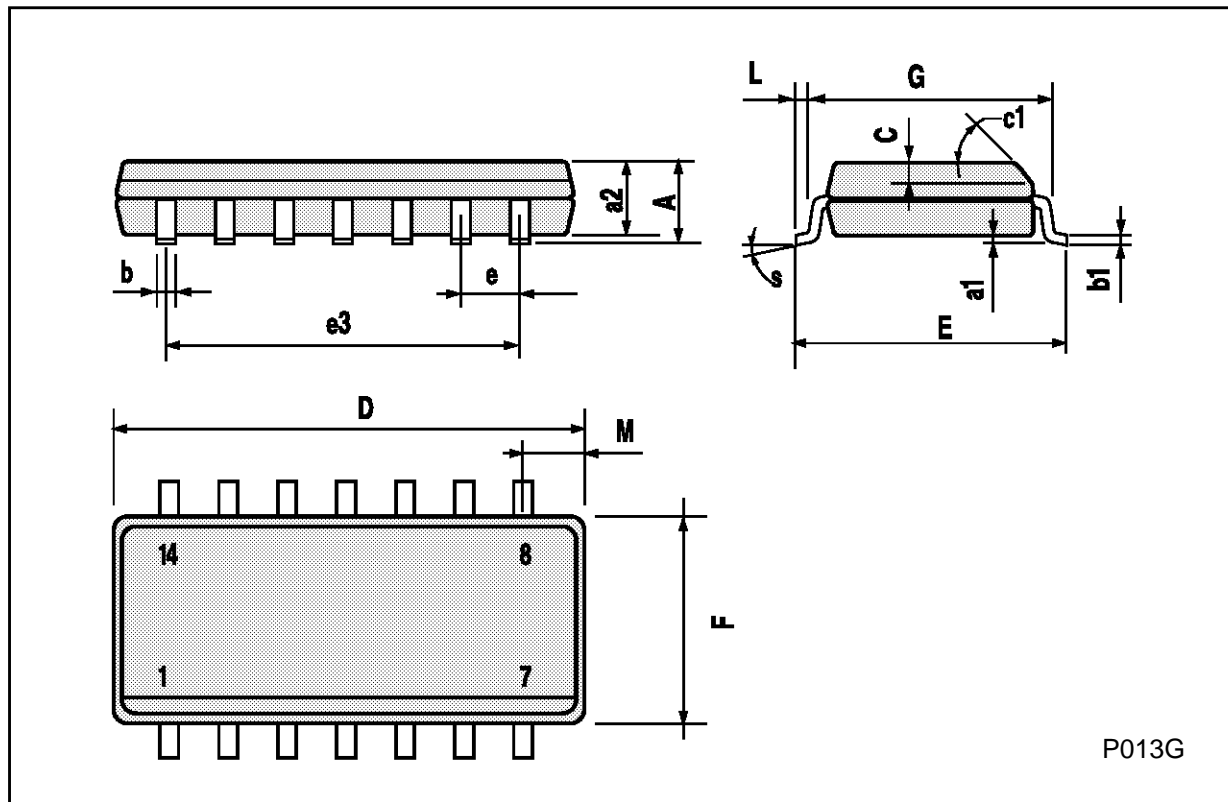

PLCC20 MECHANICAL DATA

DIM.	mm			inch		
	MIN.	TYP.	MAX.	MIN.	TYP.	MAX.
A	9.78		10.03	0.385		0.395
B	8.89		9.04	0.350		0.356
D	4.2		4.57	0.165		0.180
d1		2.54			0.100	
d2		0.56			0.022	
E	7.37		8.38	0.290		0.330
e		1.27			0.050	
e3		5.08			0.200	
F		0.38			0.015	
G			0.101			0.004
M		1.27			0.050	
M1		1.14			0.045	



Information furnished is believed to be accurate and reliable. However, SGS-THOMSON Microelectronics assumes no responsibility for the consequences of use of such information nor for any infringement of patents or other rights of third parties which may result from its use. No license is granted by implication or otherwise under any patent or patent rights of SGS-THOMSON Microelectronics. Specifications mentioned in this publication are subject to change without notice. This publication supersedes and replaces all information previously supplied. SGS-THOMSON Microelectronics products are not authorized for use as critical components in life support devices or systems without express written approval of SGS-THOMSON Microelectronics.

© 1994 SGS-THOMSON Microelectronics - All Rights Reserved

SGS-THOMSON Microelectronics GROUP OF COMPANIES

Australia - Brazil - France - Germany - Hong Kong - Italy - Japan - Korea - Malaysia - Malta - Morocco - The Netherlands -  
Singapore - Spain - Sweden - Switzerland - Taiwan - Thailand - United Kingdom - U.S.A