

OCTAL D-TYPE LATCH WITH 3 STATE OUTPUT

HCT373 NON INVERTING - HCT533 INVERTING

- HIGH SPEED
 $t_{PD} = 17 \text{ ns (TYP.) AT } V_{CC} = 5 \text{ V}$
- LOW POWER DISSIPATION
 $I_{CC} = 4 \mu\text{A (MAX.) AT } T_A = 25 \text{ }^\circ\text{C}$
- COMPATIBLE WITH TTL OUTPUTS
 $V_{IH} = 2\text{V (MIN.) } V_{IL} = 0.8\text{V (MAX.)}$
- OUTPUT DRIVE CAPABILITY
 15 LSTTL LOADS
- SYMMETRICAL OUTPUT IMPEDANCE
 $I_{OL} = |I_{OH}| = 6 \text{ mA (MIN.)}$
- BALANCED PROPAGATION DELAYS
 $t_{PLH} = t_{PHL}$
- PIN AND FUNCTION COMPATIBLE
 WITH 54/74LS373/533

DESCRIPTION

The M54/74HCT373 and M54HCT533 are high speed CMOS OCTAL LATCH WITH 3-STATE OUTPUTS fabricated with in silicon gate C²MOS technology.

These ICs achieve the high speed operation similar to equivalent LSTTL while maintaining the CMOS low power dissipation.

These 8 bit D-Type latches are controlled by a latch enable input (LE) and a output enable input (\overline{OE}).

While the LE input is held at a high level, the Q outputs will follow the data input precisely or inversely. When the LE is taken low, the Q outputs will be latched precisely or inversely at the logic level of D input data. While the \overline{OE} input is at low level, the eight outputs will be in a normal logic state (high

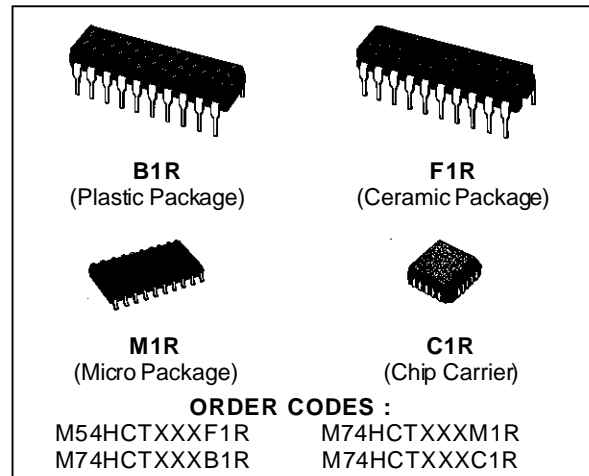

or low logic level) and while high level the outputs will be in a high impedance state. The application designer has a choice of combination of inverting and non inverting outputs. The three state output configuration and the wide choice of outline make bus organized system simple.

These integrated circuits have input and output characteristics that are fully compatible with 54/74 LSTTL logic families. M54/74HCT devices are designed to directly interface HSC²MOS systems with TTL and NMOS components. They are also plug in replacements for LSTTL devices giving a reduction of power consumption. All inputs are equipped with protection circuits against discharge and transient excess voltage.

PIN CONNECTION (top view)

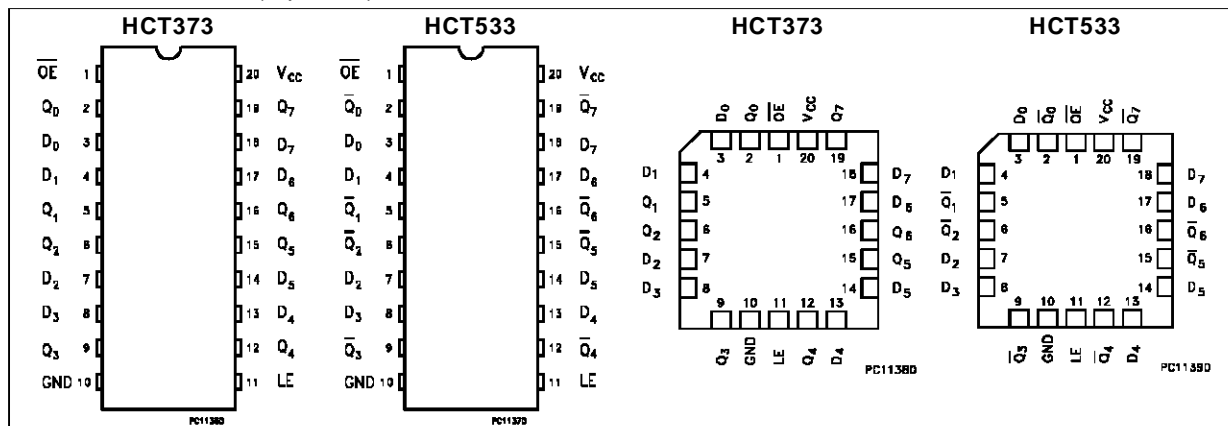

INPUT AND OUTPUT EQUIVALENT CIRCUIT



PIN DESCRIPTION (HCT373)

PIN No	SYMBOL	NAME AND FUNCTION
1	\overline{OE}	3 State output Enable Input (Active LOW)
2, 5, 6, 9, 12, 15, 16, 19	Q0 to Q7	3 State outputs
3, 4, 7, 8, 13, 14, 17, 18	D0 to D7	Data Inputs
11	LE	Latch Enable Input
10	GND	Ground (0V)
20	Vcc	Positive Supply Voltage

PIN DESCRIPTION (HCT533)

PIN No	SYMBOL	NAME AND FUNCTION
1	\overline{OE}	3 State output Enable Input (Active LOW)
2, 5, 6, 9, 12, 15, 16, 19	$\overline{Q0}$ to $\overline{Q7}$	3 State outputs
3, 4, 7, 8, 13, 14, 17, 18	D0 to D7	Data Inputs
11	LE	Latch Enable Input
10	GND	Ground (0V)
20	Vcc	Positive Supply Voltage

IEC LOGIC SYMBOLS

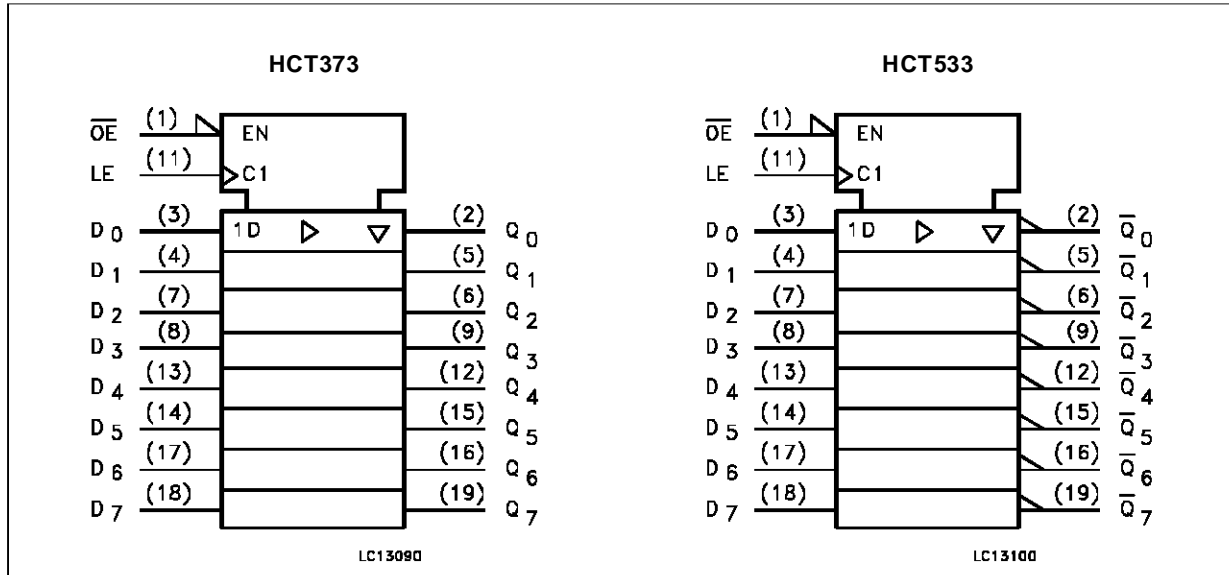

TRUTH TABLE

INPUTS			OUTPUTS	
OE	LE	D	Q (HCT373)	Q̄ (HCT533)
H	X	X	Z	Z
L	L	X	NO CHANGE *	NO CHANGE *
L	H	L	L	H
L	H	H	H	L

X: DON'T CARE
 Z: HIGH IMPEDANCE
 *: Q/Q̄ OUTPUTS ARE LATCHED AT THE TIME WHEN THE LE INPUT IS TAKEN LOW LOGIC LEVEL.

LOGIC DIAGRAMS

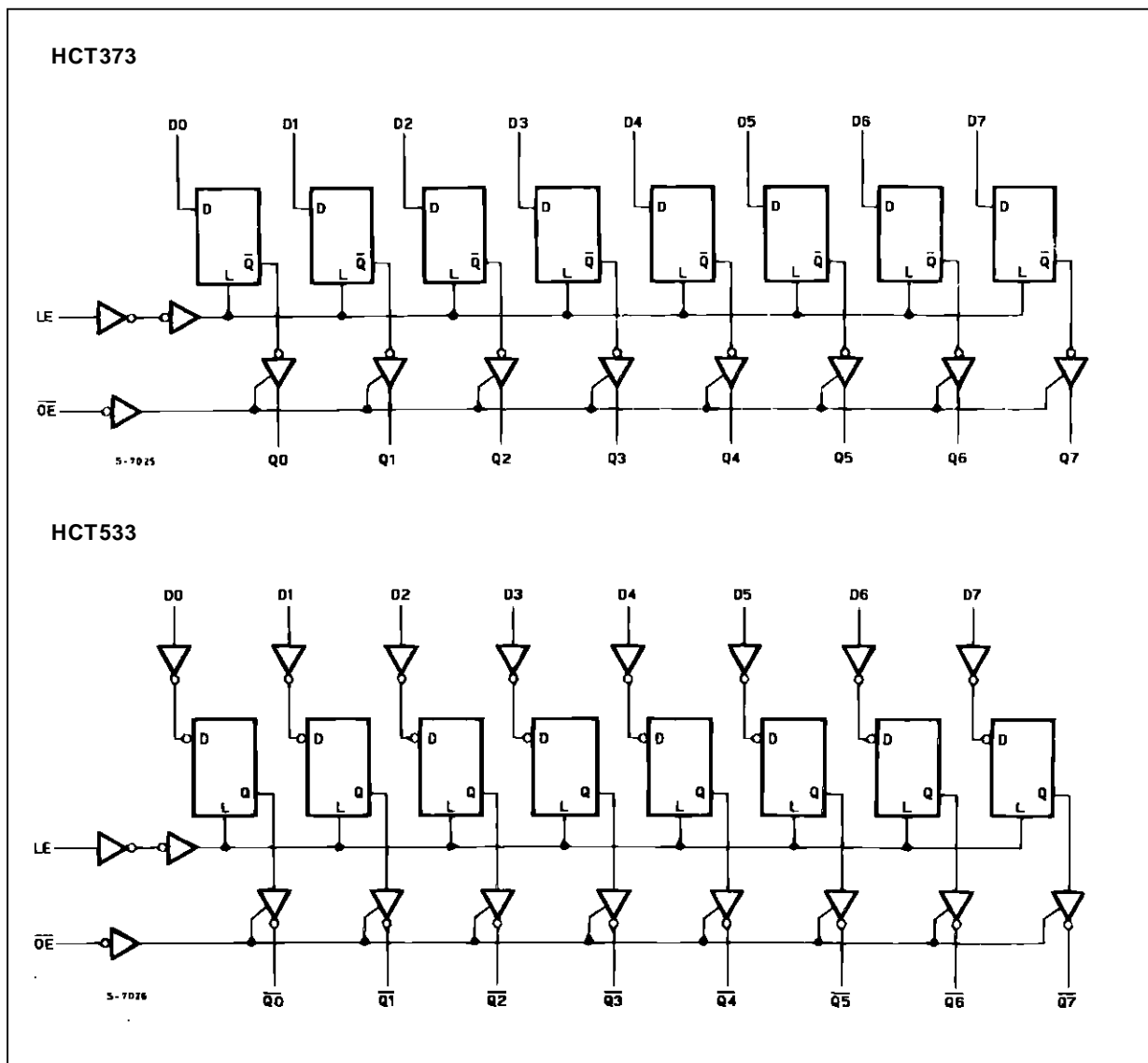

ABSOLUTE MAXIMUM RATINGS

Symbol	Parameter	Value	Unit
V _{CC}	Supply Voltage	-0.5 to +7	V
V _I	DC Input Voltage	-0.5 to V _{CC} + 0.5	V
V _O	DC Output Voltage	-0.5 to V _{CC} + 0.5	V
I _{IK}	DC Input Diode Current	± 20	mA
I _{OK}	DC Output Diode Current	± 20	mA
I _O	DC Output Source Sink Current Per Output Pin	± 35	mA
I _{CC} or I _{GND}	DC V _{CC} or Ground Current	± 70	mA
P _D	Power Dissipation	500 (*)	mW
T _{stg}	Storage Temperature	-65 to +150	°C
T _L	Lead Temperature (10 sec)	300	°C

Absolute Maximum Ratings are those values beyond which damage to the device may occur. Functional operation under these condition is not implied.

(*) 500 mW: ≡ 65 °C derate to 300 mW by 10mW/°C: 65 °C to 85 °C

RECOMMENDED OPERATING CONDITIONS

Symbol	Parameter	Value	Unit
V _{CC}	Supply Voltage	4.5 to 5.5	V
V _I	Input Voltage	0 to V _{CC}	V
V _O	Output Voltage	0 to V _{CC}	V
T _{op}	Operating Temperature: M54HC Series	-55 to +125	°C
	M74HC Series	-40 to +85	°C
t _r , t _f	Input Rise and Fall Time (V _{CC} = 4.5 to 5.5V)	0 to 500	ns

DC SPECIFICATIONS

Symbol	Parameter	Test Conditions		Value						Unit	
		V _{CC} (V)		T _A = 25 °C 54HC and 74HC			-40 to 85 °C 74HC		-55 to 125 °C 54HC		
				Min.	Typ.	Max.	Min.	Max.	Min.		Max.
V _{IH}	High Level Input Voltage	4.5 to 5.5		2.0			2.0		2.0		V
V _{IL}	Low Level Input Voltage	4.5 to 5.5				0.8		0.8		0.8	V
V _{OH}	High Level Output Voltage	4.5	V _I = V _{IH} or V _{IL}	I _O = -20 μA	4.4	4.5		4.4		4.4	V
				I _O = -6.0 mA	4.18	4.31		4.13		4.10	
V _{OL}	Low Level Output Voltage	4.5	V _I = V _{IH} or V _{IL}	I _O = 20 μA		0.0	0.1		0.1	0.1	V
				I _O = 6.0 mA		0.17	0.26		0.33	0.4	
I _I	Input Leakage Current	5.5	V _I = V _{CC} or GND			±0.1		±1		±1	μA
I _{OZ}	3 State Output Off State Current	6.0	V _I = V _{IH} or V _{IL} V _O = V _{CC} or GND			±0.5		±5.0		±10	μA
I _{CC}	Quiescent Supply Current	5.5	V _I = V _{CC} or GND			4		40		80	μA
ΔI _{CC}	Additional worst case supply current	5.5	Per Input pin V _I = 0.5V or V _I = 2.4V Other Inputs at V _{CC} or GND			2.0		2.9		3.0	mA

AC ELECTRICAL CHARACTERISTICS (Input $t_r = t_f = 6$ ns)

Symbol	Parameter	Test Conditions			Value						Unit	
		V _{CC} (V)	C _L (pF)		T _A = 25 °C 54HC and 74HC			-40 to 85 °C 74HC		-55 to 125 °C 54HC		
					Min.	Typ.	Max.	Min.	Max.	Min.		Max.
t _{TLH} t _{THL}	Output Transition Time	4.5	50			7	12		15		18	ns
t _{PLH} t _{PHL}	Propagation Delay Time (LE - Q)	4.5	50			20	30		38		45	ns
		4.5	150			24	37		46		56	ns
t _{PLH} t _{PHL}	Propagation Delay Time (D - Q)	4.5	50			19	30		38		45	ns
		4.5	150			23	36		45		54	ns
t _{PZL} t _{PZH}	3 State Output Enable Time (OE - Q)	4.5	50	R _L = 1 KΩ		20	30		38		45	ns
		4.5	150	R _L = 1 KΩ		24	37		46		56	ns
t _{PLZ} t _{PHZ}	3 State Output Disable Time (OE - Q)	4.5	50	R _L = 1 KΩ		20	30		38		45	ns
t _{W(H)}	Minimum Pulse Width (LE)	4.5	50			8	15		19		22	ns
t _s	Minimum Set-up Time	4.5	50			4	10		13		15	ns
t _h	Minimum Hold Time	4.5	50				5		5		8	ns
C _{IN}	Input Capacitance					5	10		10		10	pF
C _{PD} (*)	Power Dissipation Capacitance			HCT373 HCT533		66 52						pF

(*) C_{PD} is defined as the value of the IC's internal equivalent capacitance which is calculated from the operating current consumption without load. (Refer to Test Circuit). Average operating current can be obtained by the following equation. $I_{CC(opr)} = C_{PD} \cdot V_{CC} \cdot f_{IN} + I_{CC}/8$ (per Flip Flop) and the CPD when N pcs of Flip Flop operate, can be gained by following equation:
 CPD (TOTAL) = 32 + 34 x n [pF] (for HCT373); 30 + 22 x n [pF] (for HCT533)

SWITCHING CHARACTERISTICS TEST WAVEFORM

t_{PLH} , t_{PHL} , t_s , t_h , t_w

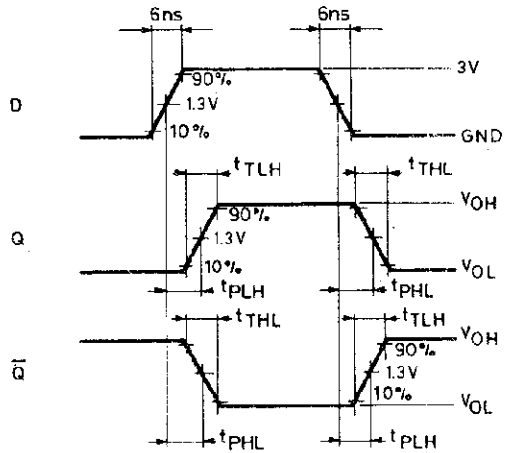

S-10427/A

f_{MAX}

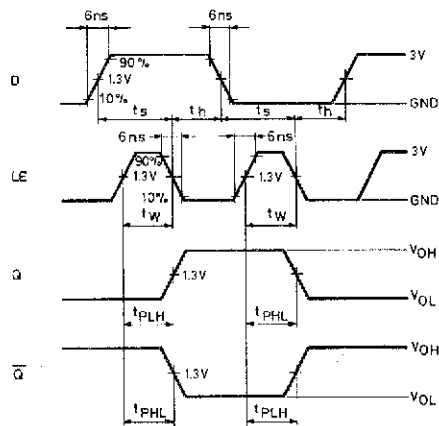

S-10428

t_{PLZ} , t_{PZL}

The $1K\Omega$ load resistors should be connected between outputs and V_{CC} line and the $50pF$ load capacitors should be connected between outputs and GND line. All inputs except \overline{OE} input should be connected to V_{CC} line or GND line such that outputs will be in low logic level while \overline{OE} input is held low.

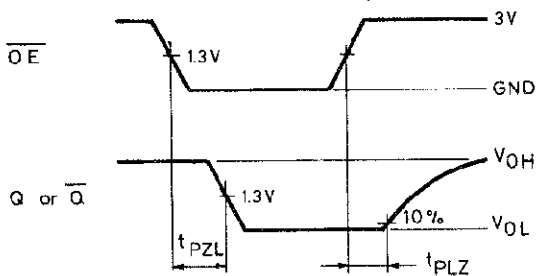

S-10429

t_{PHZ} , t_{PZH}

The $1K\Omega$ load resistors and the $50pF$ load capacitors should be connected between each output and GND line. All inputs except \overline{OE} input should be connected to V_{CC} or GND line such that output will be in high logic level while \overline{OE} input is held low.

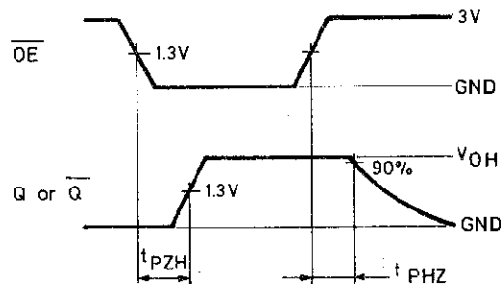

S-10430

M54/M74HCT373/533

TEST CIRCUIT I_{CC} (Opr.)

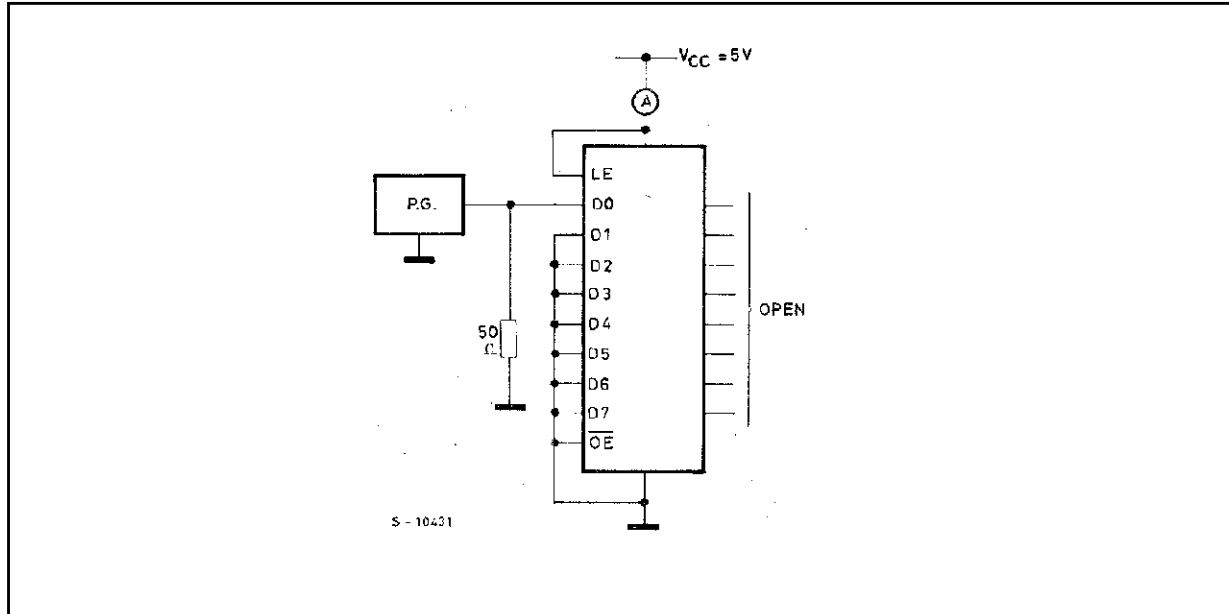

Plastic DIP20 (0.25) MECHANICAL DATA

DIM.	mm			inch		
	MIN.	TYP.	MAX.	MIN.	TYP.	MAX.
a1	0.254			0.010		
B	1.39		1.65	0.055		0.065
b		0.45			0.018	
b1		0.25			0.010	
D			25.4			1.000
E		8.5			0.335	
e		2.54			0.100	
e3		22.86			0.900	
F			7.1			0.280
I			3.93			0.155
L		3.3			0.130	
Z			1.34			0.053

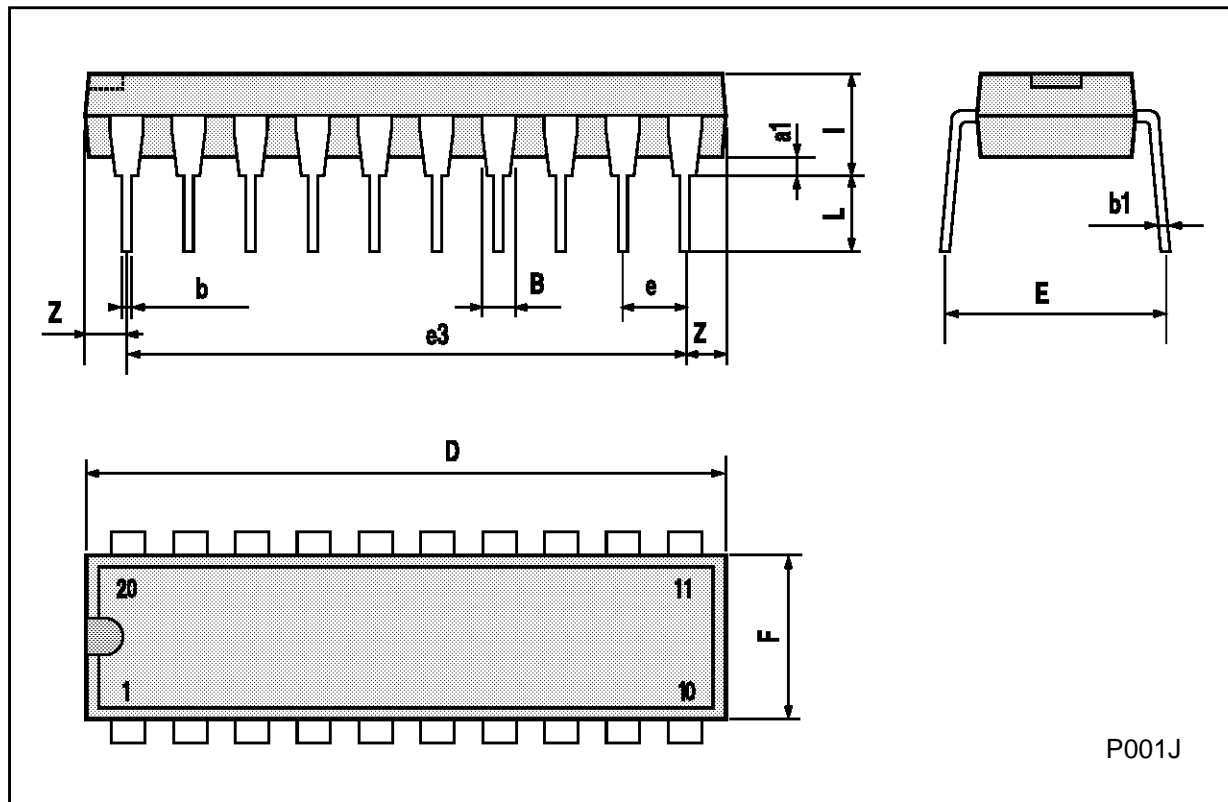

Ceramic DIP20 MECHANICAL DATA

DIM.	mm			inch		
	MIN.	TYP.	MAX.	MIN.	TYP.	MAX.
A			25			0.984
B			7.8			0.307
D		3.3			0.130	
E	0.5		1.78	0.020		0.070
e3		22.86			0.900	
F	2.29		2.79	0.090		0.110
G	0.4		0.55	0.016		0.022
I	1.27		1.52	0.050		0.060
L	0.22		0.31	0.009		0.012
M	0.51		1.27	0.020		0.050
N1	4° (min.), 15° (max.)					
P	7.9		8.13	0.311		0.320
Q			5.71			0.225

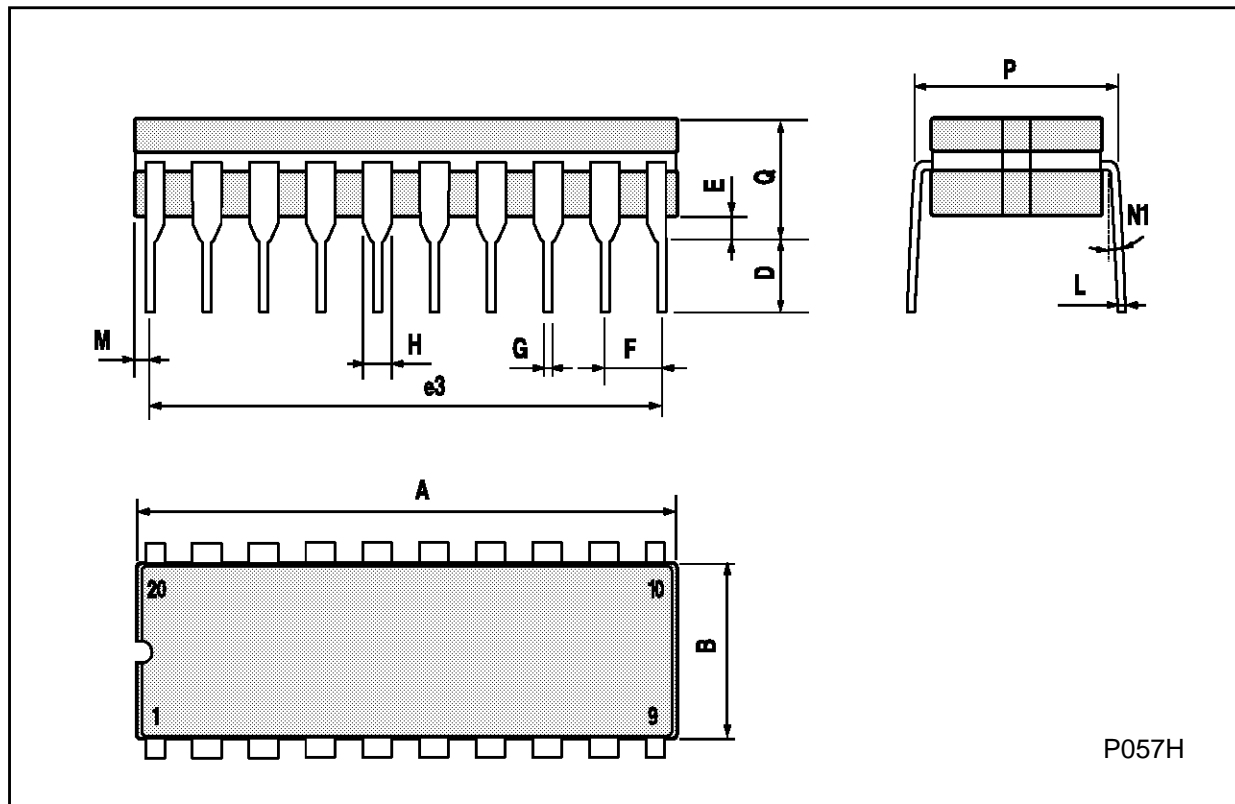

SO20 MECHANICAL DATA

DIM.	mm			inch		
	MIN.	TYP.	MAX.	MIN.	TYP.	MAX.
A			2.65			0.104
a1	0.10		0.20	0.004		0.007
a2			2.45			0.096
b	0.35		0.49	0.013		0.019
b1	0.23		0.32	0.009		0.012
C		0.50			0.020	
c1	45° (typ.)					
D	12.60		13.00	0.496		0.512
E	10.00		10.65	0.393		0.419
e		1.27			0.050	
e3		11.43			0.450	
F	7.40		7.60	0.291		0.299
L	0.50		1.27	0.19		0.050
M			0.75			0.029
S	8° (max.)					

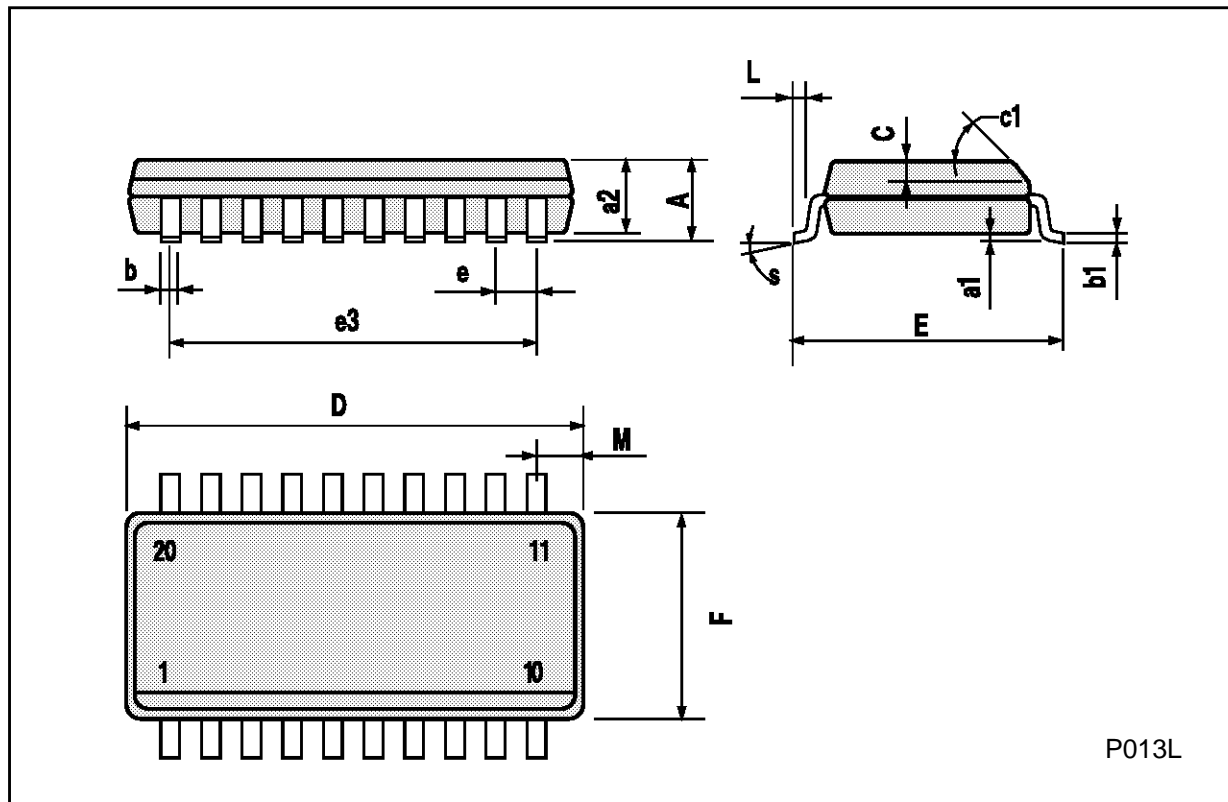

PLCC20 MECHANICAL DATA

DIM.	mm			inch		
	MIN.	TYP.	MAX.	MIN.	TYP.	MAX.
A	9.78		10.03	0.385		0.395
B	8.89		9.04	0.350		0.356
D	4.2		4.57	0.165		0.180
d1		2.54			0.100	
d2		0.56			0.022	
E	7.37		8.38	0.290		0.330
e		1.27			0.050	
e3		5.08			0.200	
F		0.38			0.015	
G			0.101			0.004
M		1.27			0.050	
M1		1.14			0.045	



Information furnished is believed to be accurate and reliable. However, SGS-THOMSON Microelectronics assumes no responsibility for the consequences of use of such information nor for any infringement of patents or other rights of third parties which may result from its use. No license is granted by implication or otherwise under any patent or patent rights of SGS-THOMSON Microelectronics. Specifications mentioned in this publication are subject to change without notice. This publication supersedes and replaces all information previously supplied. SGS-THOMSON Microelectronics products are not authorized for use as critical components in life support devices or systems without express written approval of SGS-THOMSON Microelectronics.

© 1994 SGS-THOMSON Microelectronics - All Rights Reserved

SGS-THOMSON Microelectronics GROUP OF COMPANIES

Australia - Brazil - France - Germany - Hong Kong - Italy - Japan - Korea - Malaysia - Malta - Morocco - The Netherlands -
Singapore - Spain - Sweden - Switzerland - Taiwan - Thailand - United Kingdom - U.S.A