

SGS-THOMSON MICROELECTRONICS M54/74HCT245/640/643

OCTAL BUS TRANSCEIVER (3-STATE): HCT245 NON INVERTING HCT640 INVERTING, HCT643 INVERTING/NON INVERTING

- HIGH SPEED
 $t_{PD} = 10 \text{ ns (TYP.) at } V_{CC} = 5V$
- LOW POWER DISSIPATION
 $I_{CC} = 4 \mu A \text{ (MAX.) at } T_A = 25^\circ C$
- COMPATIBLE WITH TTL OUTPUTS
 $V_{IH} = 2V \text{ (MIN.) } V_{IL} = 0.8V \text{ (MAX.)}$
- OUTPUT DRIVE CAPABILITY
 15 LSTTL LOADS
- SYMMETRICAL OUTPUT IMPEDANCE
 $|I_{OH}| = I_{OL} = 6 \text{ mA (MIN)}$
- BALANCED PROPAGATION DELAYS
 $t_{PLH} = t_{PHL}$
- PIN AND FUNCTION COMPATIBLE
 WITH 54/74LS245/640/643

DESCRIPTION

The M54/74HCT245, HCT640 and HCT643 utilise silicon gate C²MOS technology to achieve operating speeds equivalent to LSTTL devices. Along with the low power dissipation and high noise immunity of standard CMOS integrated circuit, it possesses the capability to drive 15 LSTTL loads. These IC's are intended for two-way asynchronous communication between data buses, and the direction of data transmission is determined by DIR input. The enable input (\bar{G}) can be used to disable the device so that the buses are effectively isolated. All input are equipped with protection circuits against static discharge and transient discharge. These integrated circuits have input and output

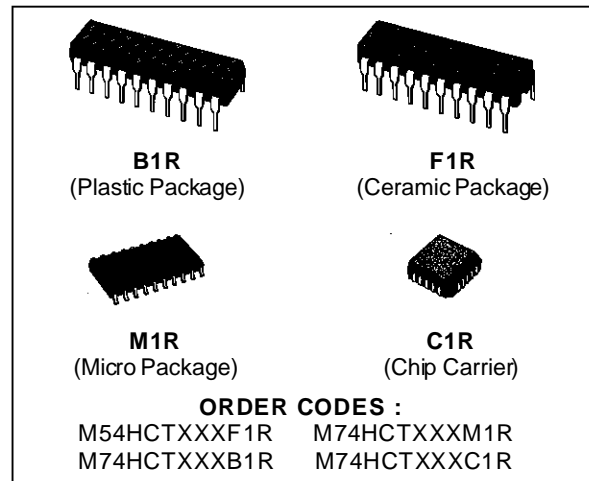

characteristics that are fully compatible with 54/74 LSTTL logic families. M54/74HCT devices are designed to directly interface HSC²MOS systems with TTL and NMOS components. They are also plug in replacements for LSTTL devices giving a reduction of power consumption.

IT IS PROHIBITED TO APPLY A SIGNAL TO A BUS TERMINAL WHEN IT IS IN OUTPUT MODE AND WHEN A BUS TERMINAL IS FLOATING (HIGH IMPEDANCE STATE), IT IS REQUESTED TO FIX THE INPUT LEVEL BY MEANS OF EXTERNAL PULL DOWN OR PULL UP RESISTOR.

PIN CONNECTION (top view)

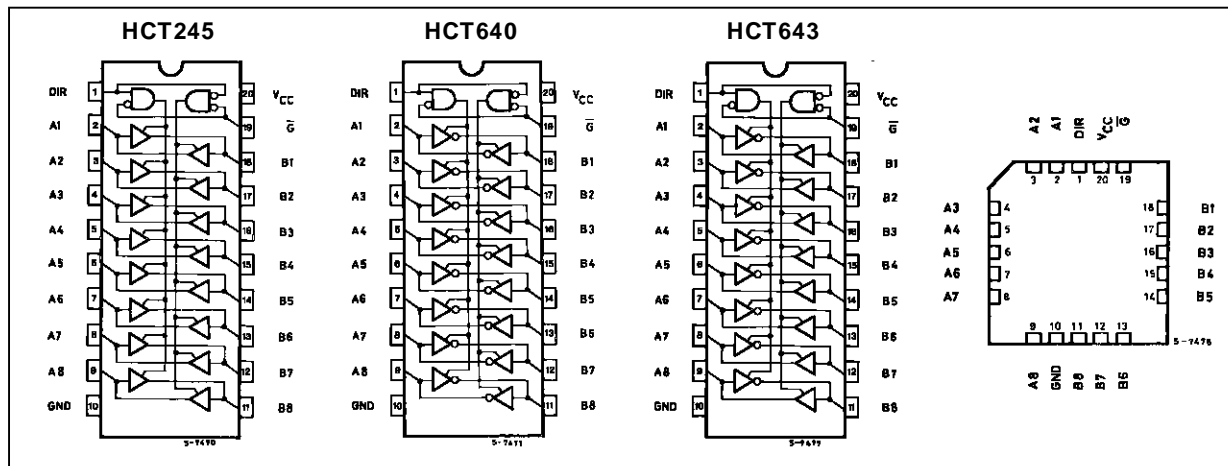

INPUT AND OUTPUT EQUIVALENT CIRCUIT

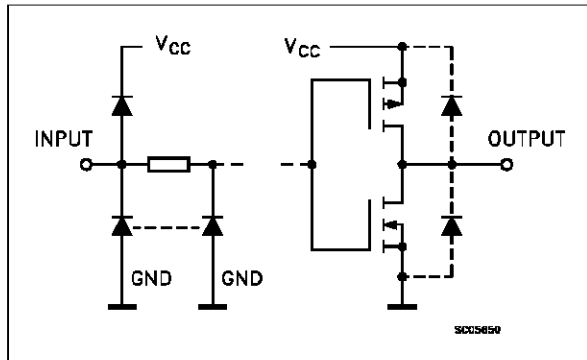

PIN DESCRIPTION

PIN No	SYMBOL	NAME AND FUNCTION
1	DIR	Directional Control
2, 3, 4, 5, 6, 7, 8, 9	A1 to A8	Data Inputs/Outputs
18, 17, 16, 15, 14, 13, 12, 11	B1 to B8	Data Inputs/Outputs
19	\bar{G}	Output Enable Input (Active LOW)
10	GND	Ground (0V)
20	V _{CC}	Positive Supply Voltage

IEC LOGIC SYMBOLS

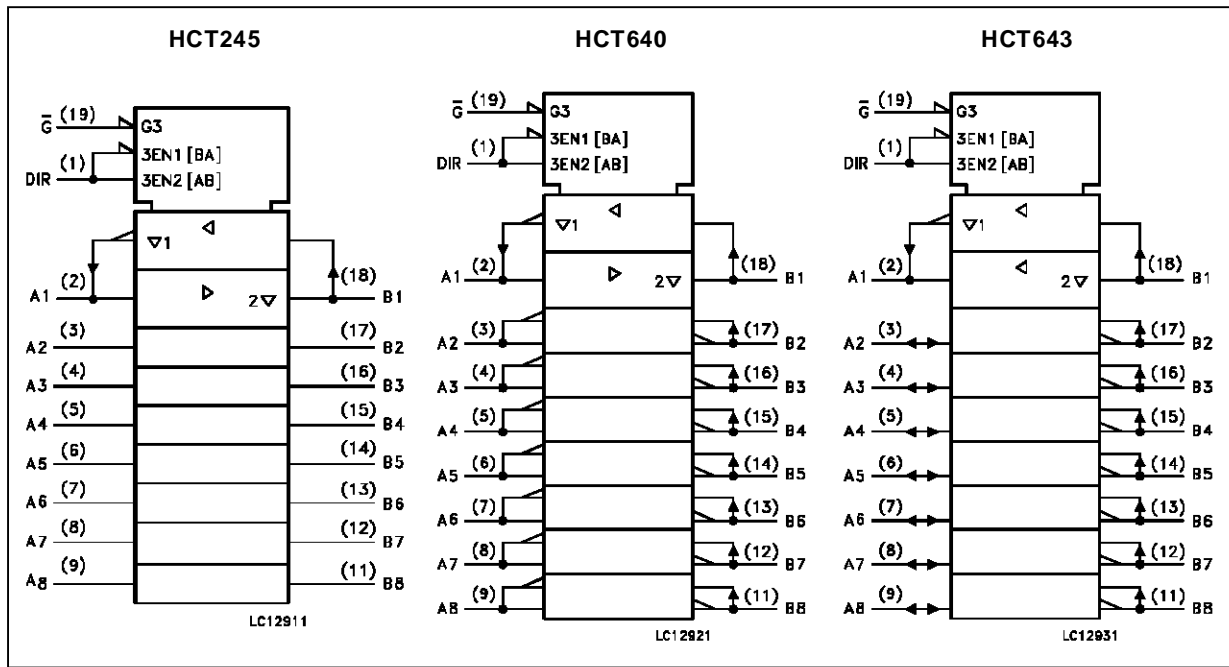

TRUTH TABLE

INPUT		FUNCTION		OUTPUT		
\bar{G}	DIR	A BUS	B BUS	HCT245	HCT640	HCT643
L	L	OUTPUT	INPUT	A = B	A = \bar{B}	A = B
L	H	INPUT	OUTPUT	B = A	B = \bar{A}	B = \bar{A}
H	X	Z	Z	Z	Z	Z

X: "H" or "L"
Z: High impedance

LOGIC DIAGRAM (HCT640)

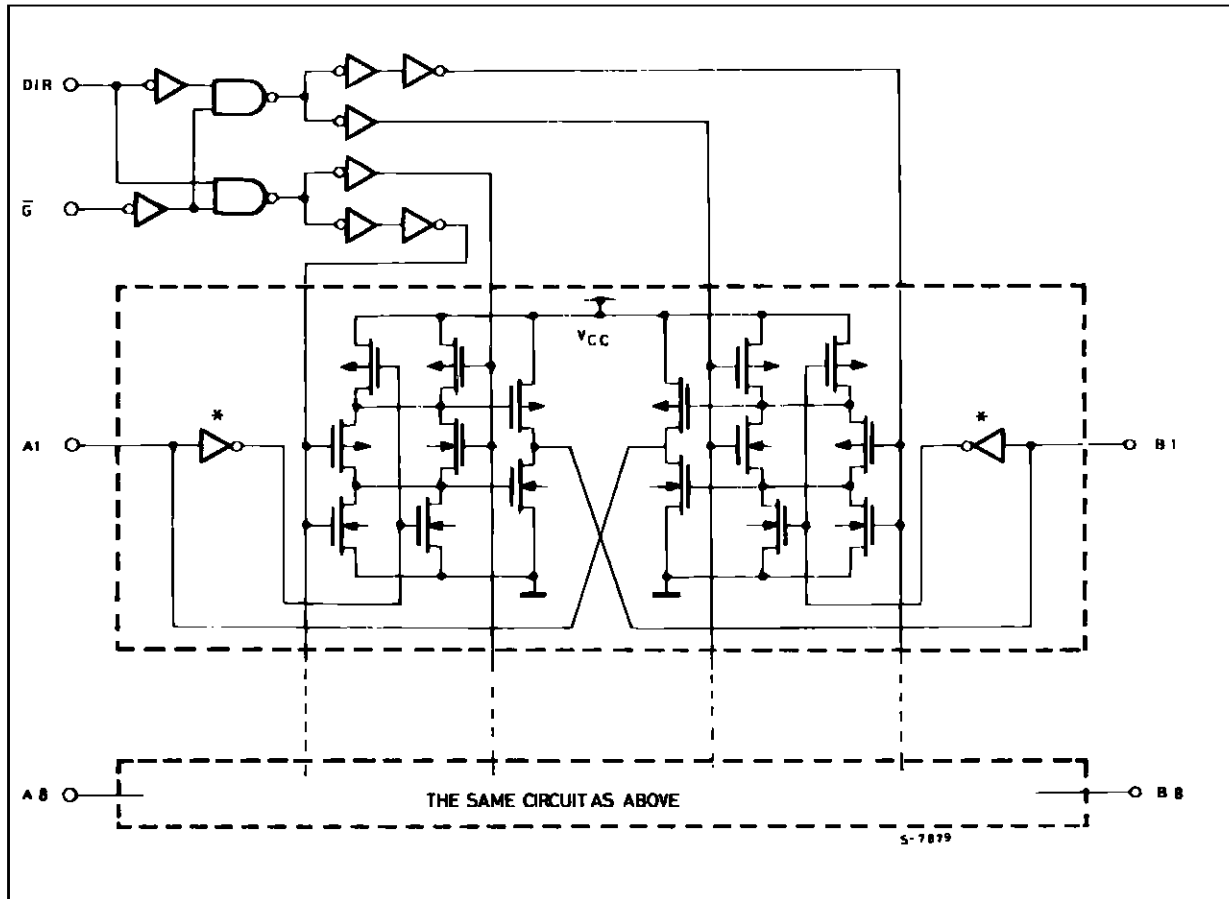

NOTE: IN CASE OF HCT245 OR HCT643, INPUT INVERTERS MARKED* AT A BUS AND B BUS ARE ELIMINATED RESPECTIVELY

ABSOLUTE MAXIMUM RATINGS

Symbol	Parameter	Value	Unit
V _{CC}	Supply Voltage	-0.5 to +7	V
V _I	DC Input Voltage	-0.5 to V _{CC} + 0.5	V
V _O	DC Output Voltage	-0.5 to V _{CC} + 0.5	V
I _{IK}	DC Input Diode Current	± 20	mA
I _{OK}	DC Output Diode Current	± 20	mA
I _O	DC Output Source Sink Current Per Output Pin	± 35	mA
I _{CC} or I _{GND}	DC V _{CC} or Ground Current	± 70	mA
P _D	Power Dissipation	500 (*)	mW
T _{stg}	Storage Temperature	-65 to +150	°C
T _L	Lead Temperature (10 sec)	300	°C

Absolute Maximum Ratings are those values beyond which damage to the device may occur. Functional operation under these condition is not implied.

(*) 500 mW: ≅ 65 °C derate to 300 mW by 10mW/°C: 65 °C to 85 °C

M54/M74HCT245/640/643

RECOMMENDED OPERATING CONDITIONS

Symbol	Parameter	Value	Unit
V_{CC}	Supply Voltage	4.5 to 5.5	V
V_I	Input Voltage	0 to V_{CC}	V
V_O	Output Voltage	0 to V_{CC}	V
T_{op}	Operating Temperature: M54HC Series M74HC Series	-55 to +125 -40 to +85	°C °C
t_r, t_f	Input Rise and Fall Time ($V_{CC} = 4.5$ to $5.5V$)	0 to 500	ns

DC SPECIFICATIONS

Symbol	Parameter	Test Conditions		Value						Unit		
		V_{CC} (V)		$T_A = 25\text{ }^\circ\text{C}$ 54HC and 74HC			-40 to $85\text{ }^\circ\text{C}$ 74HC		-55 to $125\text{ }^\circ\text{C}$ 54HC			
				Min.	Typ.	Max.	Min.	Max.	Min.		Max.	
V_{IH}	High Level Input Voltage	4.5 to 5.5		2.0			2.0		2.0		V	
V_{IL}	Low Level Input Voltage	4.5 to 5.5				0.8		0.8		0.8	V	
V_{OH}	High Level Output Voltage	4.5	$V_I = V_{IH}$ or V_{IL}	$I_O = -20\text{ }\mu\text{A}$	4.4	4.5		4.4		4.4		V
				$I_O = -6.0\text{ mA}$	4.18	4.31		4.13		4.10		
V_{OL}	Low Level Output Voltage	4.5	$V_I = V_{IH}$ or V_{IL}	$I_O = 20\text{ }\mu\text{A}$		0.0	0.1		0.1		0.1	V
				$I_O = 6.0\text{ mA}$		0.17	0.26		0.33		0.4	
I_I	Input Leakage Current	5.5	$V_I = V_{CC}$ or GND			± 0.1		± 1		± 1	μA	
I_{OZ}	3 State Output Off State Current	5.5	$V_I = V_{CC}$ or GND			± 0.5		± 5.0		± 10	μA	
I_{CC}	Quiescent Supply Current	5.5	$V_I = V_{CC}$ or GND			4		40		80	μA	
ΔI_{CC}	Additional worst case supply current	5.5	Per Input pin $V_I = 0.5V$ or $V_I = 2.4V$ Other Inputs at V_{CC} or GND $I_O = 0$			2.0		2.9		3.0	mA	

AC ELECTRICAL CHARACTERISTICS (C_L = 50 pF, Input t_r = t_f = 6 ns)

Symbol	Parameter	Test Conditions			Value						Unit	
		V _{CC} (V)	C _L (pF)		T _A = 25 °C 54HC and 74HC			-40 to 85 °C 74HC		-55 to 125 °C 54HC		
					Min.	Typ.	Max.	Min.	Max.	Min.		Max.
t _{TLH} t _{THL}	Output Transition Time	4.5	50			7	12		15		18	ns
t _{PLH} t _{PHL}	Propagation Delay Time	4.5	50			13	22		28		33	ns
		4.5	150			18	30		38		45	ns
t _{PZL} t _{PZH}	Output Enable Time	4.5	50	R _L = 1KΩ		19	30		38		45	ns
		4.5	150	R _L = 1KΩ		24	38		48		57	ns
t _{PLZ} t _{PHZ}	Output Disable Time	4.5	50	R _L = 1KΩ		17	30		38		45	ns
C _{IN}	Input Capacitance			DIR, \bar{G}		5	10		10		10	pF
C _{I/OUT}	Output Capacitance			A _n , B _n		13						pF
C _{PD} (*)	Power Dissipation Capacitance			HCT245 HCT640/643		41 39						pF

(*) C_{PD} is defined as the value of the IC's internal equivalent capacitance which is calculated from the operating current consumption without load. (Refer to Test Circuit). Average operating current can be obtained by the following equation. I_{CC(opr)} = C_{PD} • V_{CC} • f_{IN} + I_{CC}/8 (per circuit)

SWITCHING CHARACTERISTICS TEST WAVEFORM

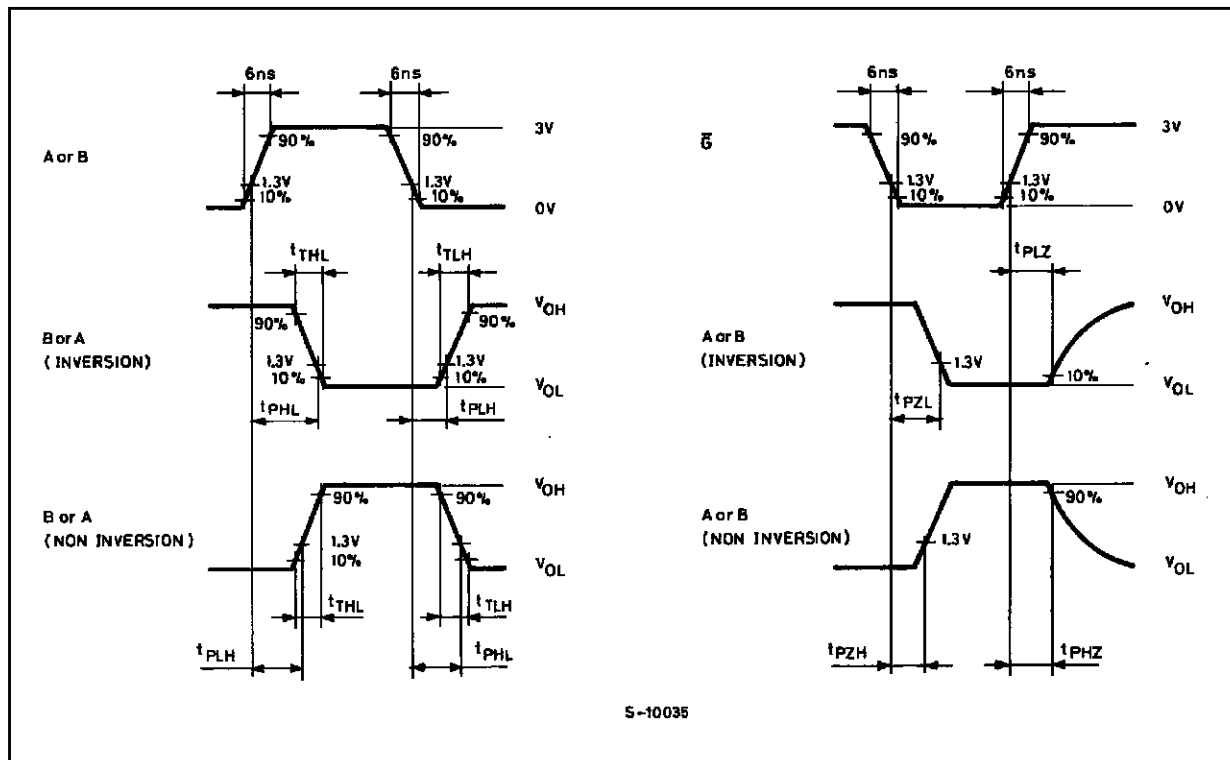

TEST CIRCUIT I_{CC} (Opr.)

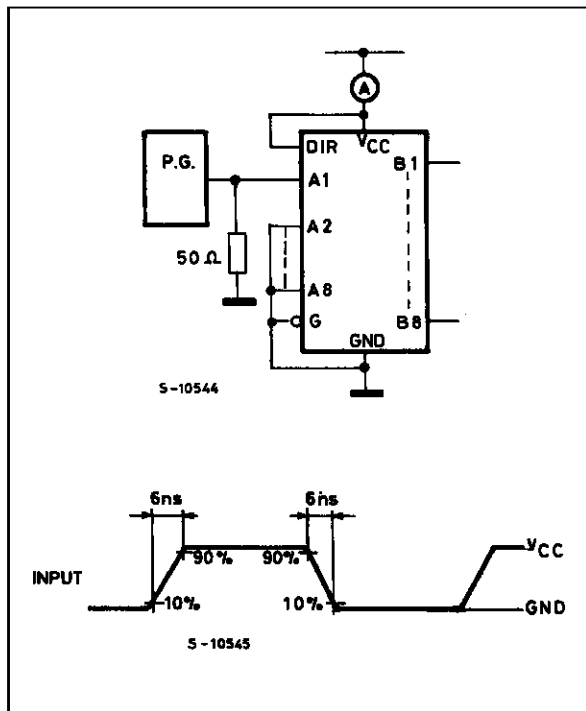

C_{PD} CALCULATION

C_{PD} is to be calculated with the following formula by using the measured value of I_{CC} (Opr.) in the test circuit opposite.

$$C_{PD} = \frac{I_{CC} (Opr.)}{f_{IN} \times V_{CC}}$$

In determining the value of C_{PD} , a relatively high frequency of 1 MHz was applied to f_{IN} , in order to eliminate any error caused by the quiescent supply current.

Plastic DIP20 (0.25) MECHANICAL DATA

DIM.	mm			inch		
	MIN.	TYP.	MAX.	MIN.	TYP.	MAX.
a1	0.254			0.010		
B	1.39		1.65	0.055		0.065
b		0.45			0.018	
b1		0.25			0.010	
D			25.4			1.000
E		8.5			0.335	
e		2.54			0.100	
e3		22.86			0.900	
F			7.1			0.280
I			3.93			0.155
L		3.3			0.130	
Z			1.34			0.053

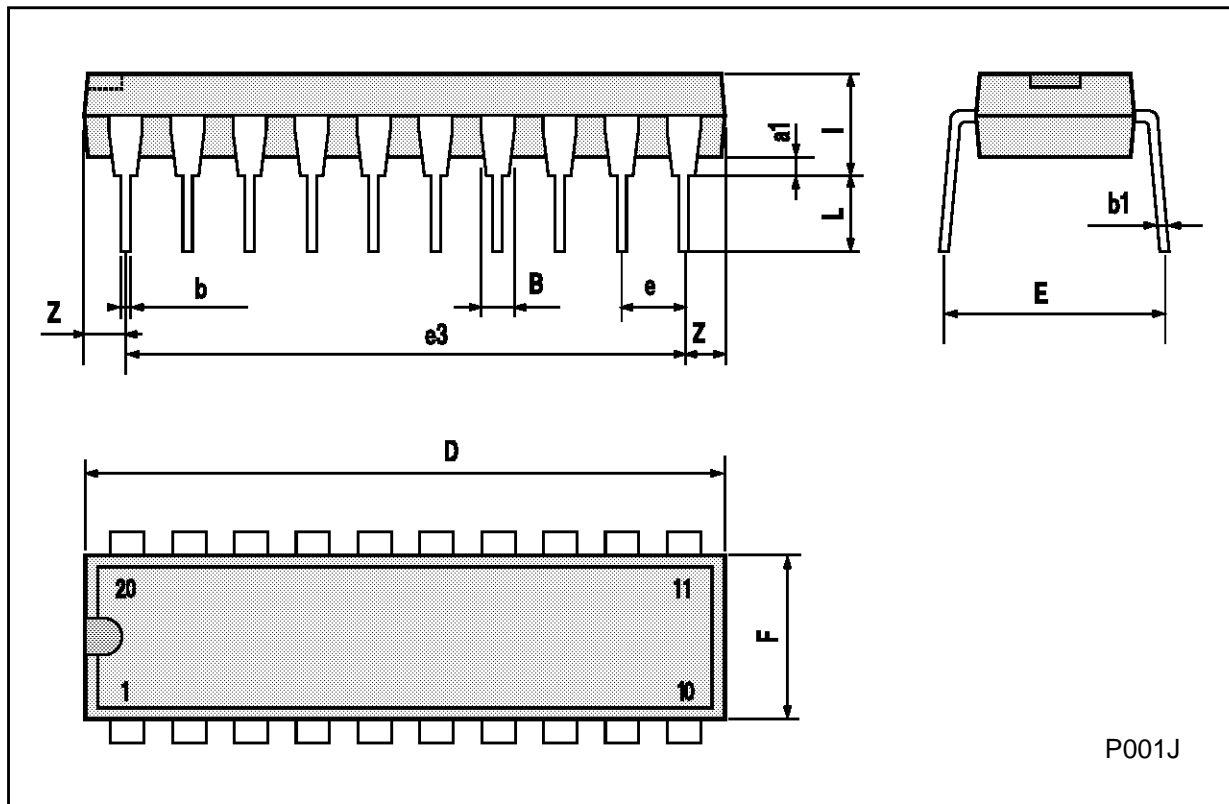

Ceramic DIP20 MECHANICAL DATA

DIM.	mm			inch		
	MIN.	TYP.	MAX.	MIN.	TYP.	MAX.
A			25			0.984
B			7.8			0.307
D		3.3			0.130	
E	0.5		1.78	0.020		0.070
e3		22.86			0.900	
F	2.29		2.79	0.090		0.110
G	0.4		0.55	0.016		0.022
I	1.27		1.52	0.050		0.060
L	0.22		0.31	0.009		0.012
M	0.51		1.27	0.020		0.050
N1	4° (min.), 15° (max.)					
P	7.9		8.13	0.311		0.320
Q			5.71			0.225

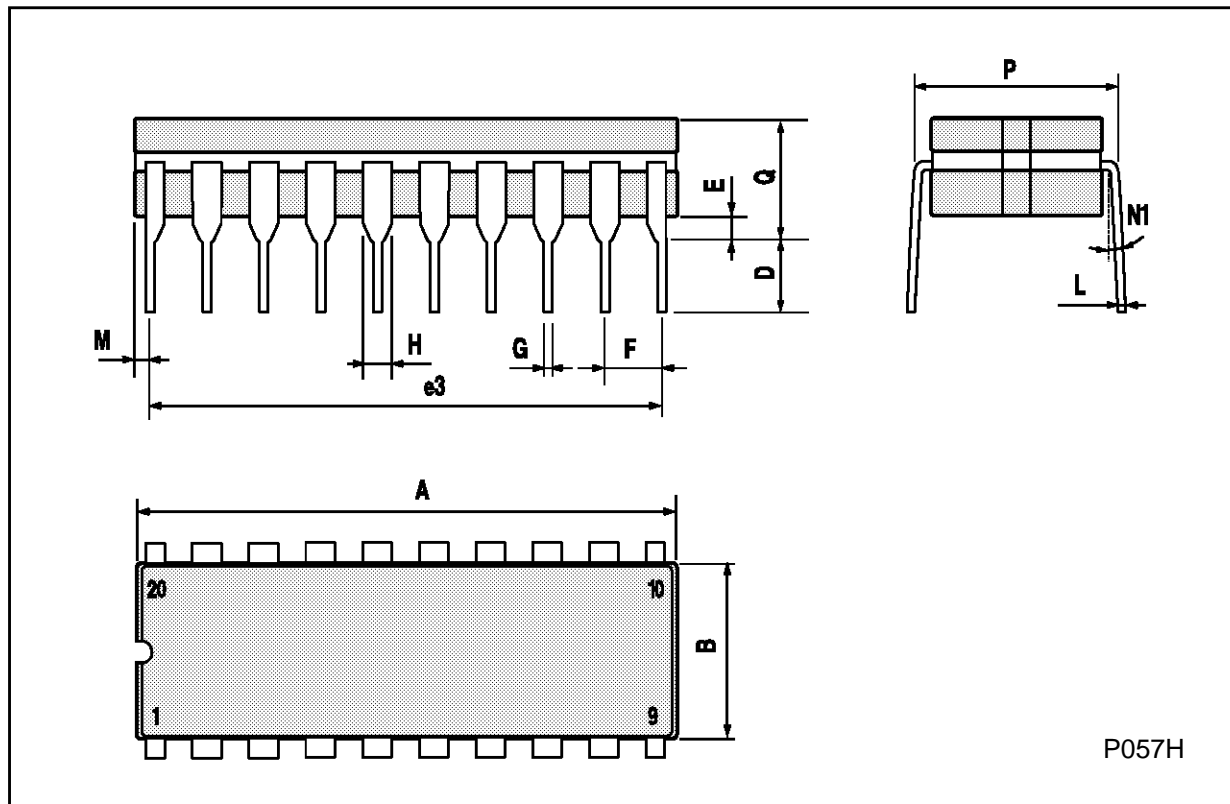

P057H

SO20 MECHANICAL DATA

DIM.	mm			inch		
	MIN.	TYP.	MAX.	MIN.	TYP.	MAX.
A			2.65			0.104
a1	0.10		0.20	0.004		0.007
a2			2.45			0.096
b	0.35		0.49	0.013		0.019
b1	0.23		0.32	0.009		0.012
C		0.50			0.020	
c1	45° (typ.)					
D	12.60		13.00	0.496		0.512
E	10.00		10.65	0.393		0.419
e		1.27			0.050	
e3		11.43			0.450	
F	7.40		7.60	0.291		0.299
L	0.50		1.27	0.19		0.050
M			0.75			0.029
S	8° (max.)					

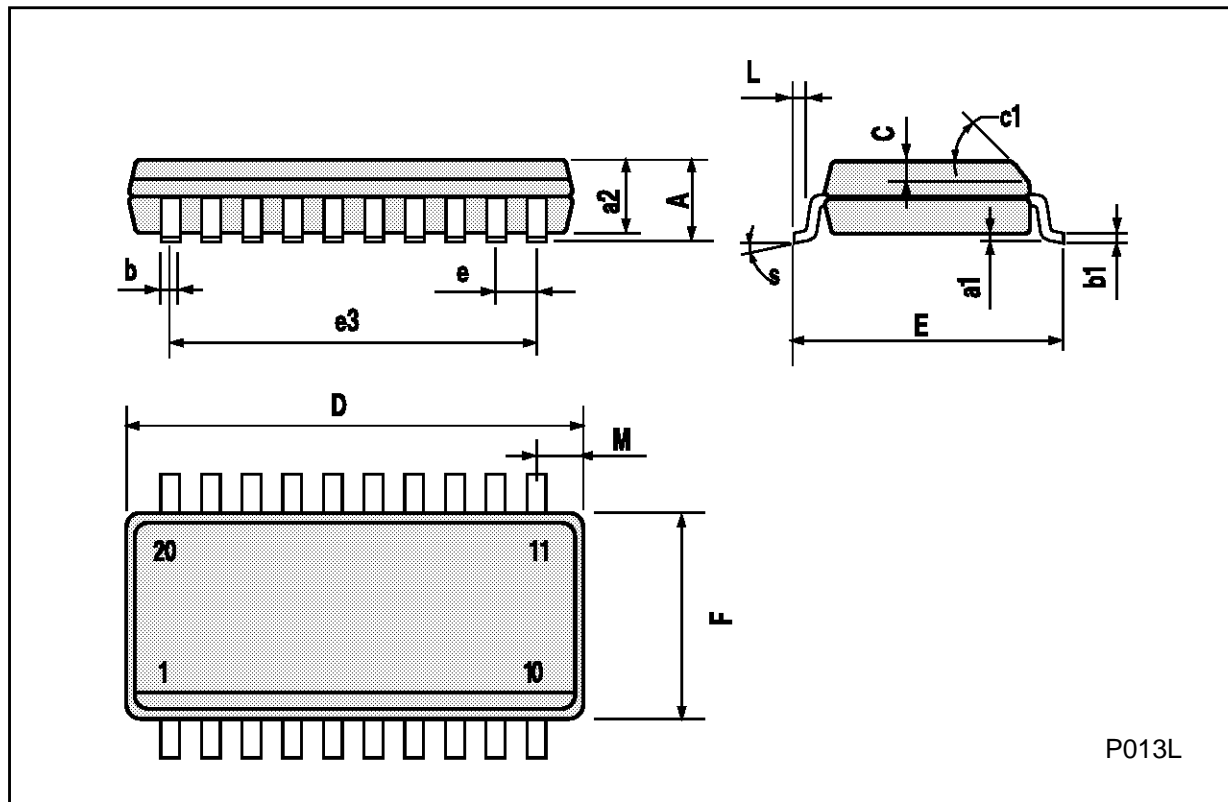

PLCC20 MECHANICAL DATA

DIM.	mm			inch		
	MIN.	TYP.	MAX.	MIN.	TYP.	MAX.
A	9.78		10.03	0.385		0.395
B	8.89		9.04	0.350		0.356
D	4.2		4.57	0.165		0.180
d1		2.54			0.100	
d2		0.56			0.022	
E	7.37		8.38	0.290		0.330
e		1.27			0.050	
e3		5.08			0.200	
F		0.38			0.015	
G			0.101			0.004
M		1.27			0.050	
M1		1.14			0.045	



Information furnished is believed to be accurate and reliable. However, SGS-THOMSON Microelectronics assumes no responsibility for the consequences of use of such information nor for any infringement of patents or other rights of third parties which may result from its use. No license is granted by implication or otherwise under any patent or patent rights of SGS-THOMSON Microelectronics. Specifications mentioned in this publication are subject to change without notice. This publication supersedes and replaces all information previously supplied. SGS-THOMSON Microelectronics products are not authorized for use as critical components in life support devices or systems without express written approval of SGS-THOMSON Microelectronics.

© 1994 SGS-THOMSON Microelectronics - All Rights Reserved

SGS-THOMSON Microelectronics GROUP OF COMPANIES

Australia - Brazil - France - Germany - Hong Kong - Italy - Japan - Korea - Malaysia - Malta - Morocco - The Netherlands -
Singapore - Spain - Sweden - Switzerland - Taiwan - Thailand - United Kingdom - U.S.A