

Isolated DC-to-DC Converter

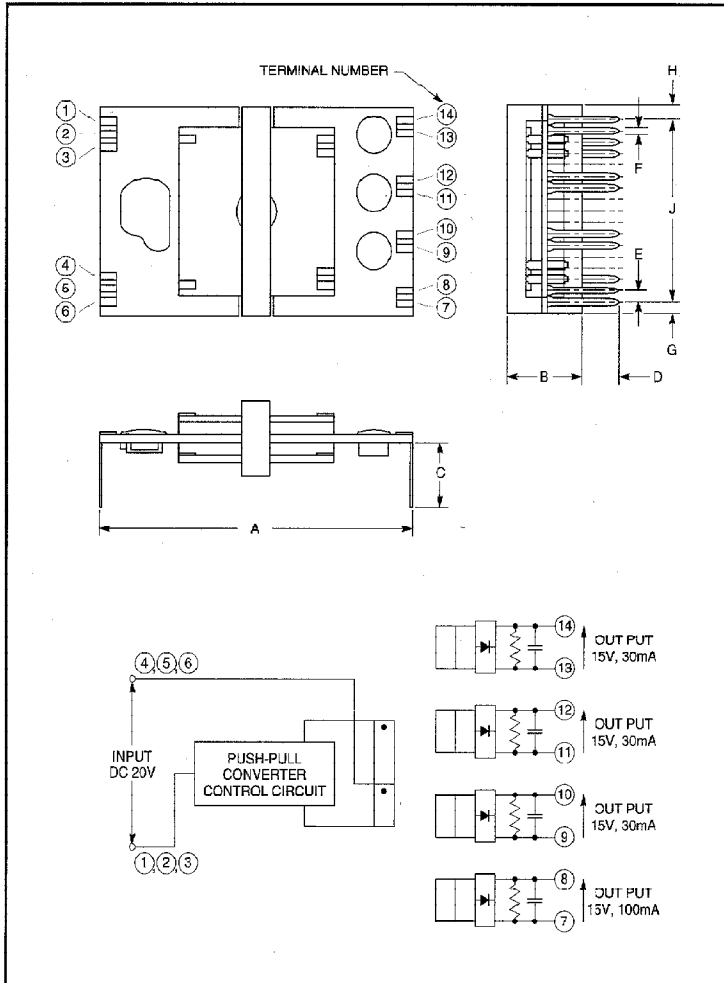

Outline Drawing and Circuit Diagram

Dimensions	Inches	Millimeters
A	2.03	51.5
B	0.71	18.0
C	.39±.06	12.5±1.5
D	.18±.06	4.5±1.5
E	0.07	1.8

Dimensions	Inches	Millimeters
F	0.02	0.55
G	0.08	2.1
H	0.08	2.1
J	1.13	28.8

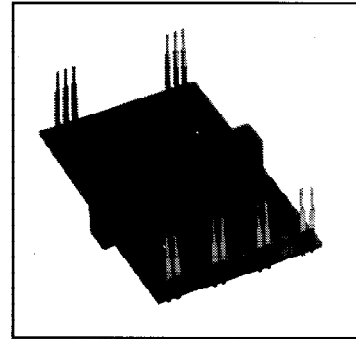

Description:

M57140-01 is an isolated DC-to-DC converter designed to drive IPMs (Intelligent Power Modules). With an input of DC 20V, the module supplies four 15V outputs. Isolation is provided from primary to secondary and also between the secondaries. Interwinding isolation is designed for driving the IPM.

Features:

- Output Specification:
+15V x 4, Total 3W max.
- Primary-to-secondary Isolation:
2500 V_{RMS}, One Minute
- Secondary-to-secondary Isolation Voltage:
1500 V_{RMS}, One Minute
- Compact, Low Profile Design

Applications:

- IPMs for General Purpose Inverter and AC Servo
- Power Source for MOSFET Driving Circuits

Ordering Information:

M57140-01



Powerex, Inc., 200 Hillis Street, Youngwood, Pennsylvania 15697-1800 (724) 925-7272

M57140-01
Isolated
DC-to-DC Converter

Absolute Maximum Ratings, $V_{IN} = 20V$, $T_a = 25^\circ C$ unless otherwise specified

Characteristics	Symbol	Test Conditions	M57140-01	Units
Input Voltage	V_{IN}	Terminals (4), (5), (6)-(1), (2), (3)	25	Volts
Load Current	I_L	Terminals (14)-(13), (12)-(11), (10)-(9)	30	mA
		Terminals (8)-(7)	100	mA
Operating Temperature	T_{opr}	There Should be	-10 ~ +75	$^\circ C$
Storage Temperature	T_{stg}	No Condensation	-20 ~ +85	$^\circ C$
Internal Power Dissipation	P_d	-	1.5	Watts
Primary-to-Secondary Isolation		1 Minute	2500	V_{rms}
Secondary-to-Secondary Isolation		1 Minute	1500	V_{rms}

Electrical Characteristics, $V_{IN} = 20V$, $T_a = 25^\circ C$ unless otherwise specified

Characteristics	Symbol	Test Conditions	Min.	Typ.	Max.	Units
Input Source Voltage	V_{IN}	Direct Current	18	20	22	Volts
Output Voltage	V_O	Between Pins (10)-(9), (12)-(11), (14)-(13) $I_L = 30mA$	13.5	15.0	16.5	Volts
		Between Pins (8)-(7), $I_L = 100mA$	13.5	15.0	16.5	Volts
Peak Load Current	I_{LP}	Between Pins (10)-(9), (12)-(11), (14)-(13)	-	33	-	mA
		Between Pins (8)-(7)	-	110	-	mA
Load Regulation	Reg-out	Between Pins (10)-(9), (12)-(11), (14)-(13) $I_L = 0 \sim 30mA$	-	5	10	%
		Between Pins (8)-(7), $I_L = 0 \sim 100mA$	-	7	12	%
Efficiency	h	Between Pins (10)-(9), (12)-(11), (14)-(13) $I_L = 30mA$	-	70	-	%
		Between Pins (8)-(7), $I_L = 100mA$	-	70	-	%

Application Circuit

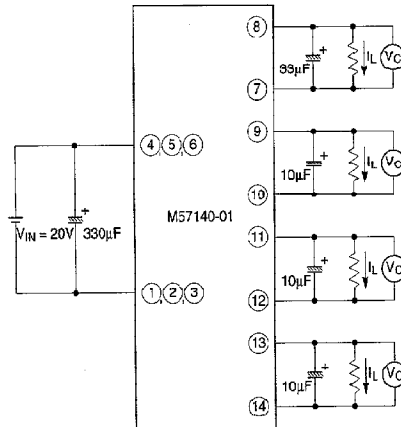



Powerex, Inc., 200 Hillis Street, Youngwood, Pennsylvania 15697-1600 (724) 925-7272

M57140-01
Isolated
DC-to-DC Converter

Application Circuit

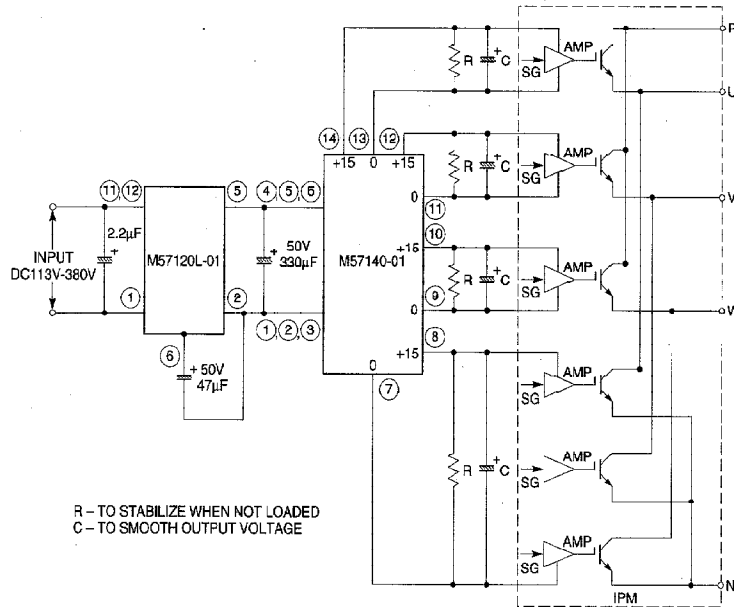

Handling Precautions:

- When M57140-01 is used under excessive load condition, output side rectifying diodes will be destroyed. Care should be exercised so as not to operate the device above the rated maximum load current.
- Coating Materials should not be applied on this device because the application of coating materials for waterproofing could cause a stress and destroy a device.



Powerex, Inc., 200 Hillis Street, Youngwood, Pennsylvania 15697-1800 (724) 925-7272

M57140-01
Isolated
DC-to-DC Converter

