

# M57962L

HYBRID IC FOR DRIVING IGBT MODULES

Block Diagram

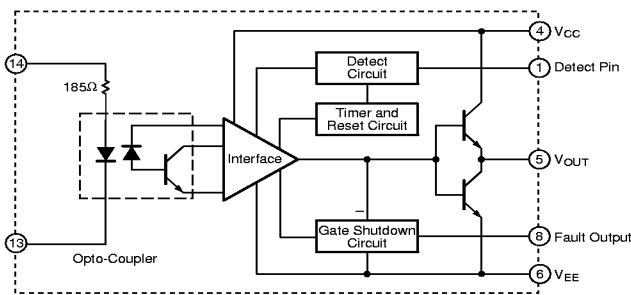

Outline Drawing

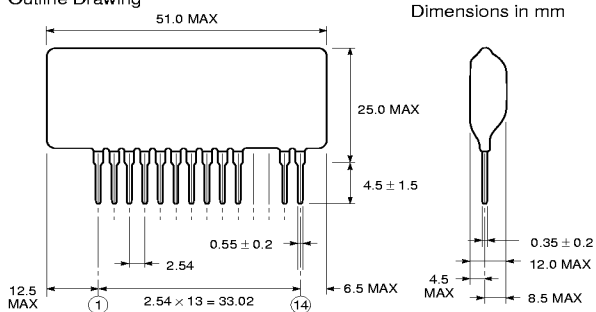

Test Circuit

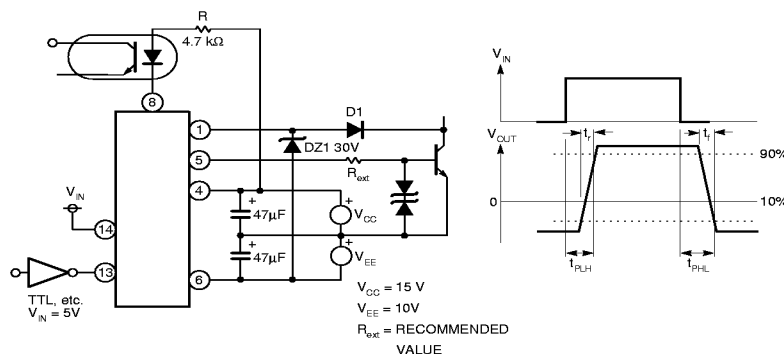

## Hybrid Integrated Circuit For Driving IGBT Modules

### Description:

M57962L is a hybrid integrated circuit designed for driving n-channel IGBT modules in any gate amplifier application. This device operates as an isolation amplifier for these modules and provides the required electrical isolation between the input and output with an opto-coupler. Short circuit protection is provided by a built in desaturation detector. A fault signal is provided if the short circuit protection is activated.

### Features:

- Built in high CMRR opto-coupler ( $V_{CMR}$  : Typical 30kV/μs, Min. 15kV/μs)
- Electrical Isolation between input and output with opto-couplers ( $V_{ISO} = 2500$ ,  $V_{RMS}$  for 1 min.)
- TTL compatible input interface
- Two supply drive topology
- Built in short circuit protection circuit with a pin for fault output

### Application:

To drive IGBT modules for inverter, AC Servo systems, UPS, CVCF inverter, and welding applications.

### Recommended Modules:

$V_{CES} = 600V$  Series  
(up to 400A Class)

$V_{CES} = 1200V$  Series  
(up to 200A Class)

$V_{CES} = 1400V$  Series  
(up to 200A Class)

## HYBRID IC FOR DRIVING IGBT MODULES

**Absolute Maximum Ratings,  $T_a = 25^\circ\text{C}$  unless otherwise specified**

Item	Symbol	Test Conditions	Limit	Units
Supply Voltage*	$V_{CC}$	DC	18	Volts
	$V_{EE}$	DC	-15	Volts
Input Voltage	$V_I$		-1 ~ 7	Volts
Output Voltage	$V_O$	Output Voltage "H"	$V_{CC}$	Volts
Output Current	$I_{OHP}$	Pulse Width 2 $\mu\text{s}$ , $f = 20\text{kHz}$	-5	Amperes
	$I_{OLP}$	Pulse Width 2 $\mu\text{s}$ , $f = 20\text{kHz}$	5	Amperes
Output Current	$I_{OH}$	$f = 20\text{kHz}$ , 50% Duty Cycle	0.5	Amperes
Isolation Voltage	$V_{RMS}$	Sinewave Voltage 60Hz, 1 min.	2500	Volts
Junction Temperature	$T_j$		85	$^\circ\text{C}$
Operating Temperature	$T_{opr}$	(Differs from H/C Condition)	-20 ~ 60	$^\circ\text{C}$
Storage Temperature	$t_{stg}$		-25 ~ 100	$^\circ\text{C}$
Fault Output Current	$I_{FO}$		20	mA
Input Voltage	$V_{R1}$		50	Volts

\*20 Volts  $\leq V_{CC} + V_{EE} \leq 28$  Volts**Electrical Characteristics,  $T_a = 25^\circ\text{C}$ ,  $V_{CC} = 15\text{V}$ ,  $-V_{EE} = 10\text{V}$  unless otherwise specified**

Characteristics	Symbol	Test Conditions	Min.	Typ.	Max.	Units
Supply Voltage	$V_{CC}$	Recommended Range	14	15	—	Volts
	$V_{EE}$	Recommended Range	-7	—	-10	Volts
Pull-up Voltage on Input Side	$V_{IN}$	Recommended Range	4.75	5.00	5.25	Volts
"H" Input Current	$I_{IH}$	$V_{IN} = 5\text{V}$ , $R = 185\Omega$	—	16	—	mA
"H" Output Voltage	$V_{OH}$		13	14	—	Volts
"L" Output Voltage	$V_{OL}$		-8	-9	—	Volts
Internal Power Dissipation	$P_D$	$f = 20\text{kHz}$ ,	—	2.38	—	Watts
		Module 400A, 1200V IGBT				
"L-H" Propagation Time	$t_{PLH}$	$V_I = 0$ to 4V, $T_j \pm 85^\circ\text{C}$	—	1.0	1.5	$\mu\text{s}$
"L-H" Rise Time	$t_r$	$V_I = 0$ to 4V, $T_j \pm 85^\circ\text{C}$	—	0.6	1.0	$\mu\text{s}$
"H-L" Propagation Time	$t_{PHL}$	$V_I = 0$ to 4V, $T_j \pm 85^\circ\text{C}$	—	1.0	1.5	$\mu\text{s}$
"H-L" Rise Time	$t_r$	$V_I = 0$ to 4V, $T_j \pm 85^\circ\text{C}$	—	0.4	1.0	$\mu\text{s}$
Reset Time of Protection	$t_{RESET}$		1	—	2	ms
Fault Output Current	$I_{FO}$		—	5	—	mA
SC Voltage	$V_{SC}$		15	—	—	Volts