

# M62427FP

SOUND QUALITY/SOUND FIELD CONTROL DIGITAL SOUND CONTROLLER FOR MINI-COMPONENT STEREO

## DESCRIPTION

The M62427FP is an optimum digital sound controller IC for home audio.

This IC contains a 5-element graphic equalizer, master volume, sound and karaoke functions (voice cancel). It can control all of these functions with serial data.

In addition to the tone control function, this IC provides adapter pins for digital surround, microphone mixing and key control and is optimum to the sound quality and sound field control of audio equipment with karaoke function.

## FEATURES

- 80-pin QFP package
- Capable of performing the following functions with serial data
  - 5-band tone control (0, ±3, ±6, ±10dB)
  - Bass boost (HPF type) [ON/OFF] (PASS)
  - Surround (using external delay) [ON/OFF]
  - Vocal cancel (stereo) [ON/OFF]
  - Multilingual voice record switching [LCHonly/RCHonly]
  - Electronic volume 32 steps (0dB to ∞)
  - Port output 3 lines
- Supporting digital delay
- Adapter input/output supporting karaoke key control

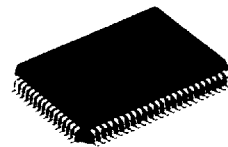

Outline 80P6N-A  
0.8mm pitch QFP  
(20.0mmX14.0mmX2.8mm)

## RECOMMENDED OPERATING CONDITIONS

Supply voltage range..... Vcc=±4.5 to ±7.5V

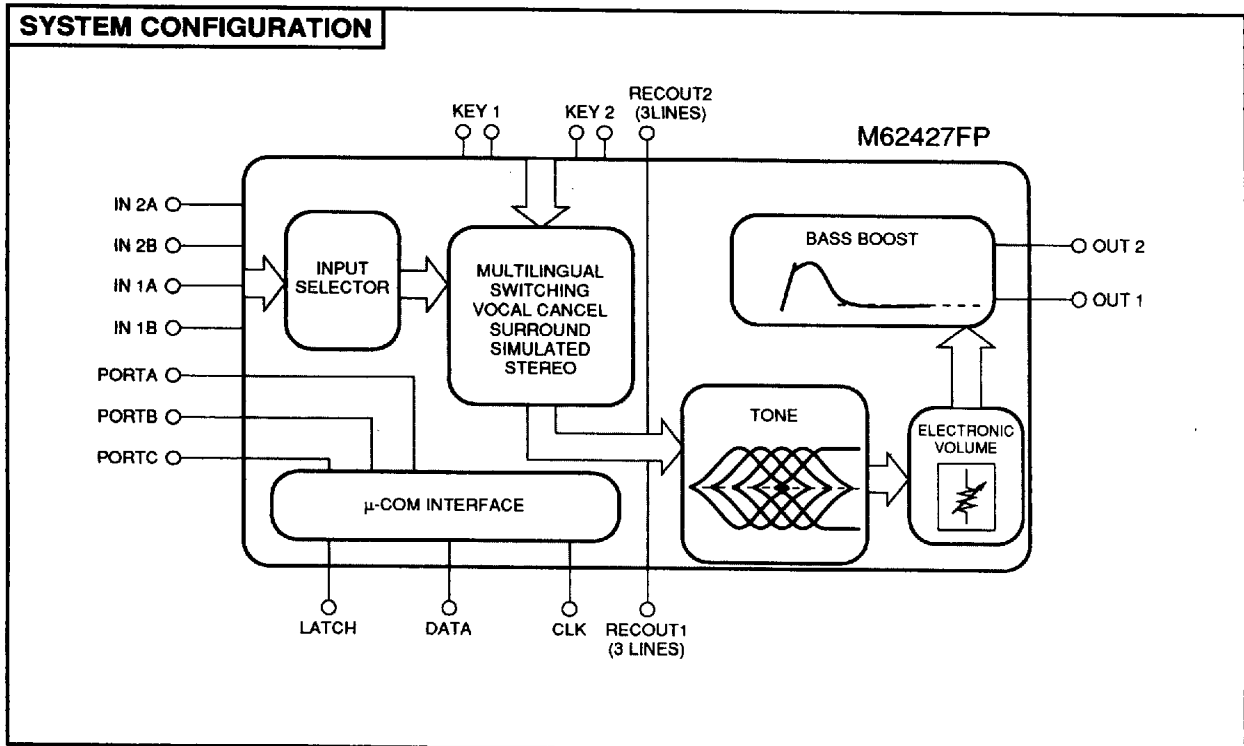

6249826 0022290 387



SOUND QUALITY/SOUND FIELD CONTROL DIGITAL SOUND CONTROLLER FOR MINI-COMPONENT STEREO

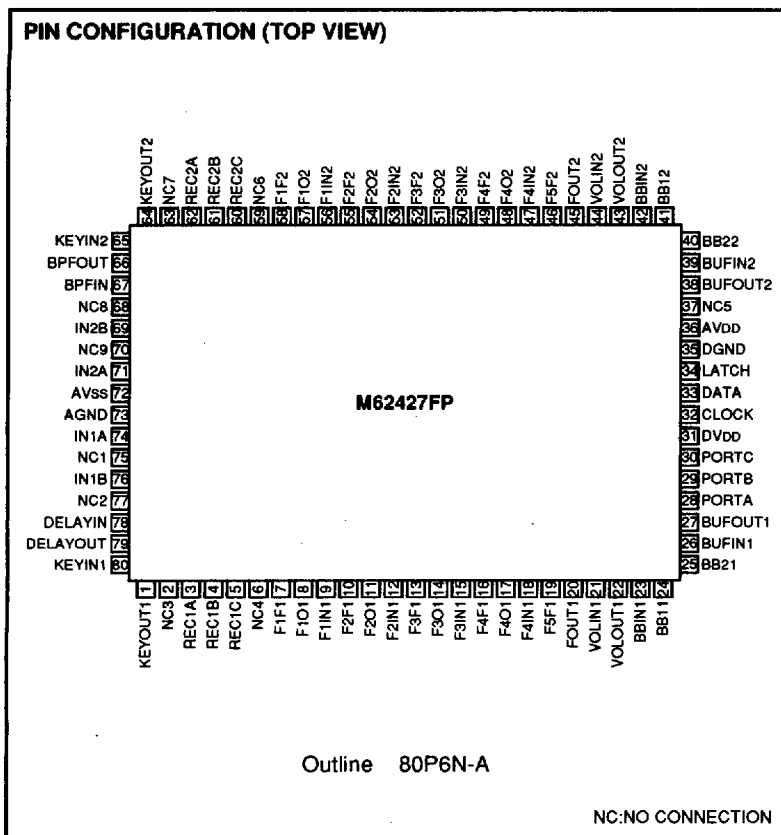

6249826 0022291 213



SOUND QUALITY/SOUND FIELD CONTROL DIGITAL SOUND CONTROLLER FOR MINI-COMPONENT STEREO

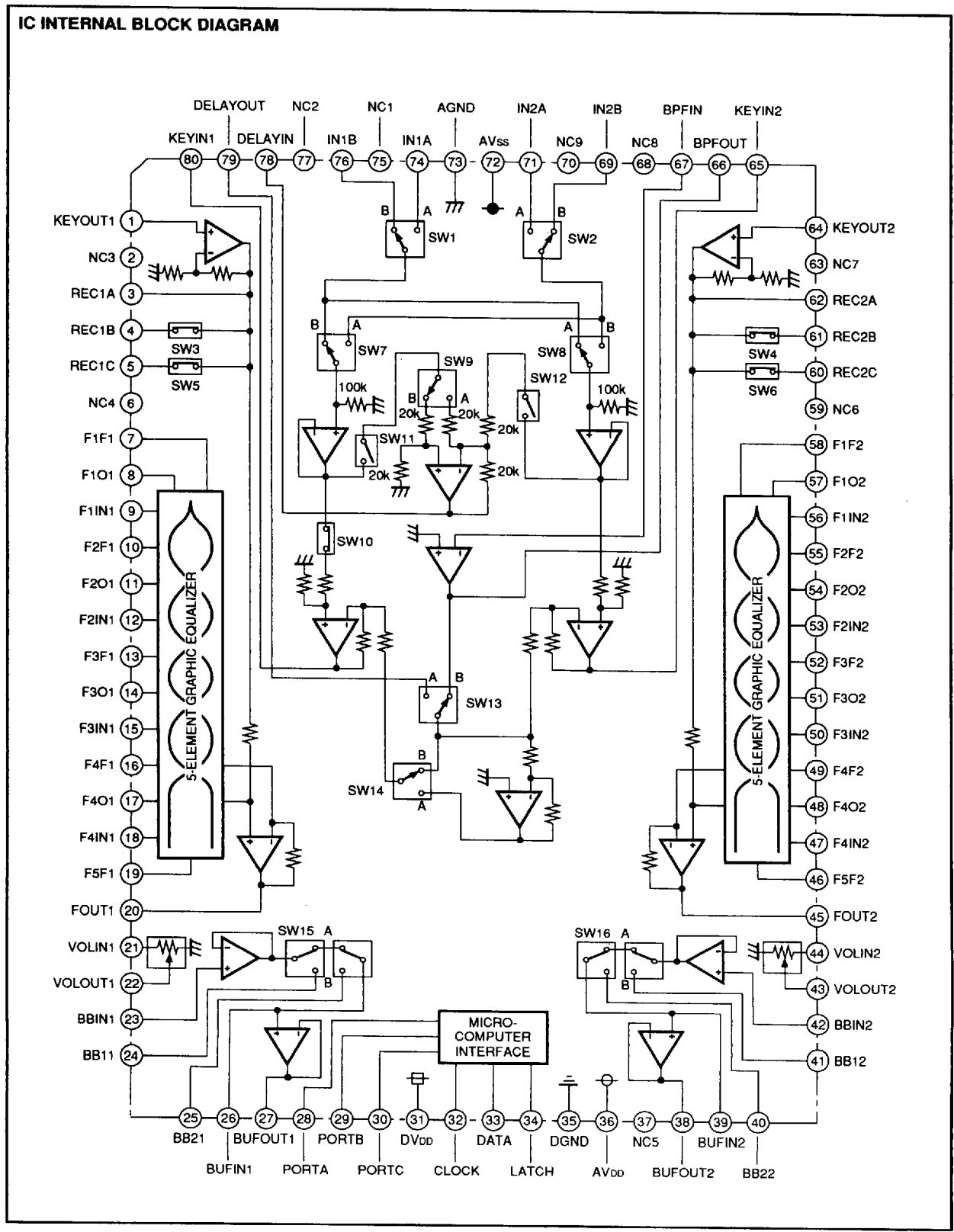

6249826 0022292 15T



## SOUND QUALITY/SOUND FIELD CONTROL DIGITAL SOUND CONTROLLER FOR MINI-COMPONENT STEREO

## PIN DESCRIPTION

Pin No.	Symbol	Function
72	AVss	Load power pin of internal analog circuit
73	AGND	Ground pin of internal analog circuit
74 71	IN1A, IN2A	Input pin of channel A
75 69	IN1B, IN2B	Input pin of channel B
76	DELAYIN	(R-L) output pin for surround. Connect to the input of the delay circuit. Total load resistance is 20kΩ
79	DELAYOUT	(R-L) input pin for surround. Connect to the output of the delay circuit.
80 65	KEYIN1, KEYIN2	Key control adapter output pin. Connect to the input of the key control circuit. Total load resistance is 20kΩ
1 64	KEYOUT1, KEYOUT2	Key control adapter input pin. Connect to the output of the key control circuit.
66	BPFOUT	Band pass filter amplifier output pin for vocal cancel
67	BPFIN	Band pass filter amplifier input pin for vocal cancel
3 62	REC1A, REC2A	REC output pin A
4 61	REC1B, REC2B	REC output pin B (with mute SW)
5 60	REC1C, REC2C	REC output pin C (with mute SW)
Total load resistance is 20kΩ min.		
7 59	F1F1, F1F2	(Band filter) connection pin of resonance impedance of the 1st element
8 57	F1O1, F1O2	Output pin of resonance buffer amplifier of the 1st element
9 56	F1IN1, F1IN2	Input pin of resonance buffer amplifier of the 1st element
10 55	F2F1, F2F2	(Band filter) connection pin of resonance impedance of the 2nd element
11 54	F2O1, F2O2	Output pin of resonance buffer amplifier of the 2nd element
12 53	F2IN1, F2IN2	Input pin of resonance buffer amplifier of the 2nd element
13 52	F3F1, F3F2	(Band filter) connection pin of resonance impedance of the 3rd element
14 51	F3O1, F3O2	Output pin of resonance buffer amplifier of the 3rd element
15 50	F3IN1, F3IN2	Input pin of resonance buffer amplifier of the 3rd element
16 49	F4F1, F4F2	(Band filter) connection pin of resonance impedance of the 4th element
17 48	F4O1, F4O2	Output pin of resonance buffer amplifier of the 4th element
18 47	F4IN1, F4IN2	Input pin of resonance buffer amplifier of the 4th element
19 46	F5F1, F5F2	Band filter connection pin of the 5th element
20 45	FOUT1, FOUT2	Tone output pin. Connect to the next stage with capacitor connection
21 44	VOLIM1, VOLIN2	R rudder volume input pin
22 43	VOLOUT1, VOLOUT2	R rudder volume output pin
23 42	BBIN1, BBIN2	Bass boost input pin
24 41	BB11, BB12	Input pin for high pass filter connection of bass boost
25 40	BB21, BB22	Output pin for high pass filter connection of bass boost
26 39	BUFIN1, BUFIN2	Input pin of bass boost buffer amplifier
27 38	BUFOUT1, BUFOUT2	Output pin of bass boost buffer amplifier
28	PORTA	Output of port A
29	PORTB	Output of port B
30	PORTC	Output of port C
31	DVDD	Power supply of internal logic circuit
32	CLOCK	Clock input pin for serial data transfer
33	DATA	Input pin of control data. Reads data at the rising edge of clock
34	LATCH	Input pin of latch signal. Changes the circuit status at the rising edge of the latch signal
35	DGND	Ground pin of the internal logic circuit
36	AVDD	Positive power pin of the internal analog circuit
75 70	NC1, NC9	Non-connection pin
77 68	NC2, NC8	
2 63	NC3, NC7	
6 58	NC4, NC6	
67	NC5	

6249826 0022293 096



SOUND QUALITY/SOUND FIELD CONTROL DIGITAL SOUND CONTROLLER FOR MINI-COMPONENT STEREO

ABSOLUTE MAXIMUM RATINGS

Symbol	Parameter	Conditions	Ratings	Unit
AVDD, AVSS	Analog supply voltage		±7.8	V
DVDD	Digital supply voltage		6.0	V
Pd	Power dissipation	TA≤25°C	1250	mW
Kθ	Thermal derating	Ta>25°C Board installation (Note 1)	12.5	mW/°C
Topr	Operating temperature		-20 to +55	°C
Tstg	Storage temperature		-55 to +125	°C

Note 1: Board

- Size of printed circuit board (140mm x 140mm)
- Thickness of printed circuit board (1.6mm)
- Material of printed circuit board (Glass epoxy)
- Single side Cu pattern Thickness of Cu (18μm)
- Cu pattern dimensions (0.25mm (width) x 50mm (length)/lead)

RECOMMENDED OPERATING CONDITIONS (Ta=25°C, unless otherwise noted)

Symbol	Parameter	Test conditions	Limits			Unit
			Min.	Typ.	Max.	
AVDD	Analog positive supply voltage	(Note 2)	4.5	7.0	7.5	V
AVSS	Analog negative supply voltage	(Note 2)	-4.5	-7.0	-7.5	V
DVDD	Digital supply voltage	DVDD≤AVDD	4.5	5.0	5.5	V
Vih	Logic "H" level input voltage		DVDD-0.7	-	VDD	V
Vil	Logic "L" level input voltage		0	-	DGND+0.7	V

Note 2: After applying AVDD, apply supply voltages in the order of AVSS and DVDD for the IC.

RELATIONSHIP BETWEEN DATA AND CLOCK

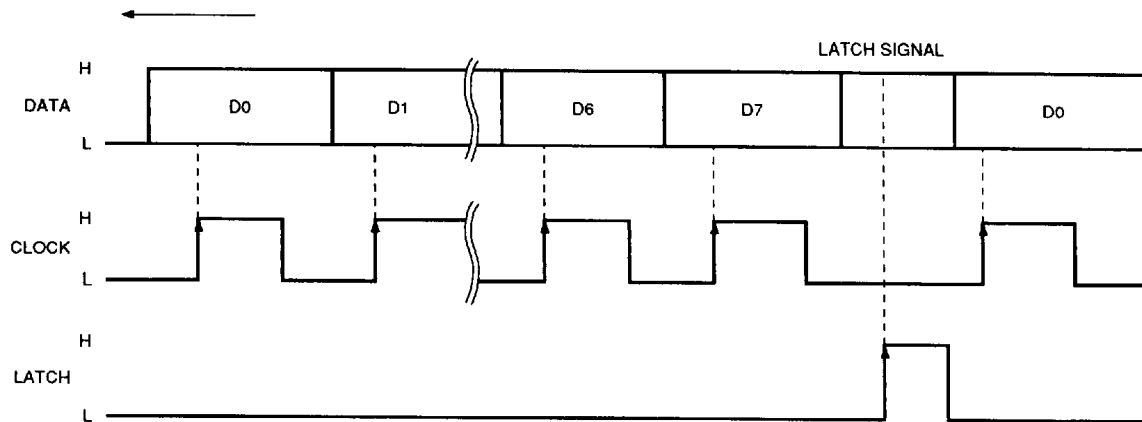

Data signal is read at the rising edge of clock.  
Signal is latched at the rising edge of the latch signal.

6249826 0022294 T22



SOUND QUALITY/SOUND FIELD CONTROL DIGITAL SOUND CONTROLLER FOR MINI-COMPONENT STEREO

ELECTRICAL CHARACTERISTICS

(Ta=25°C, AVDD=7.0V, AVSS=-7.0V, DVDD=5.0V, f=1kHz, unless otherwise noted. In addition, tone control bass boost is 0dB.)

Symbol	Parameter	Test conditions	Limits			Unit
			Min.	Typ.	Max.	
AI <sub>DD</sub>	Analog positive power circuit current	With AV <sub>DD</sub> =7.0V and AV <sub>SS</sub> =-7.0V, pin ② pin current, when no signal is provided	19	40	55	mA
AI <sub>SS</sub>	Analog negative power circuit current	With AV <sub>DD</sub> =7.0V and AV <sub>SS</sub> =-7.0V, pin ⑫ pin current, when no signal is provided	-55	-40	-19	mA
DI <sub>DD</sub>	Digital power circuit current	With DV <sub>DD</sub> =5V, pin ⑤ pin current, when no signal is provided	-	0.3	1.2	mA
RI <sub>IN</sub>	Input resistance	Pins ⑦④, ⑦⑥, ⑦① and ⑥⑨, Ta=25°C	100	200	300	kΩ
VIM	Maximum input voltage	(Input to pins ⑦④ and ⑦⑥), (input to pins ⑦① and ⑥⑨) Output from pins ②⑦ and ③⑧, R <sub>L</sub> =10kΩ, THD=1%	3.0	4.0	-	V <sub>rms</sub>
V <sub>ODC</sub>	Output pin voltage	Pin ②⑦, pin ③⑧, when no signal is provided	-0.1	0	0.1	V
V <sub>REDC</sub>		Pin ③, pin ⑥②, when no signal is provided	-0.1	0	0.1	V
G <sub>V</sub>	Pass gain	V <sub>IN</sub> =1V <sub>rms</sub> , FLAT, (pins ⑦④ and ⑦⑥), gain between (pins ⑦① and ⑥⑨) and (pins ②⑦ and ③⑧)	-20	0	2.0	dB
V <sub>ONO</sub>	Output noise voltage	JIS-A filter, when no signal is provided Pins ②⑦ and ③⑧	-	10.0	24	μV <sub>rms</sub>
V <sub>RENO</sub>		R <sub>g</sub> =10kΩ, with FLAT (path) Pins ③ and ⑥②	-	10.0	20	μV <sub>rms</sub>
THD	Distortion	Pin ②⑦, pin ③⑧, BW=400 to 30kHz V <sub>I</sub> =-20dBV, R <sub>L</sub> =10kΩ	-	0.01	0.05	%
THD <sub>REC A</sub>		Pin ③, pin ⑥②, BW=400 to 30kHz V <sub>I</sub> =-20dBV, R <sub>L</sub> =30kΩ	-	0.01	0.05	%
THD <sub>REC B, C</sub>		(Pins ④ and ⑥①), (pins ⑤ and ⑥⑨), BW=400 to 30 kHz	-	0.01	0.05	%
CT	Cross talk between channels	V <sub>O</sub> =0.5V <sub>rms</sub> , R <sub>L</sub> =10kΩ, JIS-A between pins ②⑦ and ③⑧, R <sub>g</sub> =10kΩ	-	-55	-45	dB
CT <sub>REC</sub>		V <sub>O</sub> =0.5V <sub>rms</sub> , R <sub>L</sub> =30kΩ, JIS-A between pins ③ and ⑥②, R <sub>g</sub> =10kΩ	-	-55	-45	dB
G <sub>BOOST1</sub>	Tone control	3dB 6dB 9dB -3dB -6dB -9dB f=1kHz, V <sub>O</sub> =1V <sub>rms</sub> Gain between input pins ①, ⑥④ and output pins ②⑦, ④⑤	1.5	3	4.5	dB
G <sub>BOOST2</sub>			4.5	6	7.5	dB
G <sub>BOOST3</sub>			7.0	9	11.0	dB
G <sub>CUT1</sub>			-4.5	-3	-1.5	dB
G <sub>CUT2</sub>			-7.5	-6	-4.5	dB
G <sub>CUT3</sub>			-11.0	-9	-7.0	dB
BAL <sub>TON</sub>			Balance between channels	f=1kHz, V <sub>O</sub> =1V <sub>rms</sub> , Input to pins ①, ⑥④ Output from pins ②⑦, ④⑤, each boost With +10 and -10dB	-1.5	0
V <sub>PA</sub>	Port output	R <sub>L</sub> =10kΩ	6.0	7.0	-	V
V <sub>PB</sub>						
V <sub>PC</sub>						

6249826 0022295 969



**SOUND QUALITY/SOUND FIELD CONTROL DIGITAL SOUND CONTROLLER FOR MINI-COMPONENT STEREO**

**DATA INPUT FORMAT**

Four types of input formats can be selected by changing the D6/D7 slot setting status.

(Initialize all data of the four formats when power is turned on.)

	← Input direction						Input format selection slot	
(1)	D01	D11	D21	D31	D41	D51	D6	D7
	Rec out B SW3, 4 1:Mute 0:Through	Rec out C SW5, 6 1:Mute 0:Through	Voice switching mode SW7 1:Side A 0:Side B	SW8 1:Side A 0:Side B	SW9 1:Side A 0:Side B	SW10 1:ON 0:OFF	0	0
(2)	D02	D12	D22	D32	D42	D52	D6	D7
	SW11, 12 1:ON 0:OFF	SW13 1:Side A 0:Side B	SW14 1:Side A 0:Side B	Port A 1:H 0:L	Port output Port B 1:H 0:L	Port C 1:H 0:L	0	1
(3)	D03	D13	D23	D33	D43	D53	D6	D7
	* Refer to the slot setting list (5) for tone control ----- Bass boost SW15, 16 Side A/Side B			* Refer to the slot setting code list (6) for tone boost/cut			1	0
(4)	D04	D14	D24	D34	D44	D54	D6	D7
	* Refer to the slot setting code list (7) for master volume					Input selector SW1, 2 1:Side A 0:Side B	1	1

**(5) Setting code (tone control)**

	D03	D13	D23
Tone 1 (F1)	0	0	1
Tone 2 (F2)	0	1	0
Tone 3 (F3)	0	1	1
Tone 4 (F4)	1	0	0
Tone 5 (F5)	1	0	1
Bass boost	OFF	1	0
	ON	1	1

**(6) Setting code (tone boost/cut)**

	D33	D43	D53
Boost	+0dB	0	0
	+3dB	0	1
	+6dB	0	0
	+10dB	0	1
Cut	-0dB	1	0
	-3dB	1	0
	-6dB	1	0
	-10dB	1	1

6249826 0022296 8T5



SOUND QUALITY/SOUND FIELD CONTROL DIGITAL SOUND CONTROLLER FOR MINI-COMPONENT STEREO

(7) Setting codes (master volume)

Amount of ATT	D04	D14	D24	D34	D44
- 0.0dB	0	0	0	0	0
- 2.0dB	1	0	0	0	0
- 4.0dB	0	1	0	0	0
- 6.0dB	1	1	0	0	0
- 8.0dB	0	0	1	0	0
-10.0dB	1	0	1	0	0
-12.0dB	0	1	1	0	0
-14.0dB	1	1	1	0	0
-16.0dB	0	0	0	1	0
-18.0dB	1	0	0	1	0
-20.0dB	0	1	0	1	0
-22.0dB	1	1	0	1	0
-24.0dB	0	0	1	1	0
-26.0dB	1	0	1	1	0
-28.0dB	0	1	1	1	0
-30.0dB	1	1	1	1	0
-32.0dB	0	0	0	0	1
-34.0dB	1	0	0	0	1
-36.0dB	0	1	0	0	1
-38.0dB	1	1	0	0	1
-40.0dB	0	0	1	0	1
-42.0dB	1	0	1	0	1
-44.0dB	0	1	1	0	1
-48.0dB	1	1	1	0	1
-52.0dB	0	0	0	1	1
-56.0dB	1	0	0	1	1
-60.0dB	0	1	0	1	1
-64.0dB	1	1	0	1	1
-68.0dB	0	0	1	1	1
-72.0dB	1	0	1	1	1
-76.0dB	0	1	1	1	1
-∞	1	1	1	1	1

(8) Port output setting codes

Data	Port output	
D32	0	Port A is set to L
	1	Port A is set to H
D42	0	Port B is set to L
	1	Port B is set to H
D52	0	Port C is set to L
	1	Port C is set to H

(9) Other setting codes

Voice cancel	
D41=1	SW9:Side A
D51=1	SW10:ON
D02=1	SW11, 12:ON
D12=0	SW13:Side B
D22=0	SW14:Side B

Sound	
D41=0	SW9:Side B
D51=1	SW10:ON
D02=1	SW11, 12:ON
D12=1	SW13:Side A
D22=1	SW14:Side A

Simulated stereo	
D41=1	SW9:Side A
D51=0	SW10:OFF
D02=1	SW11, 12:ON
D12=0	SW13:Side B
D22=0	SW14:Side B

Multilingual record supported			
Rch (1ch)		Lch (2ch)	
D21=0	SW7:Side B	D21=1	SW7:Side A
D31=1	SW8:Side A	D31=0	SW8:Side B

6249826 0022297 731



SOUND QUALITY/SOUND FIELD CONTROL DIGITAL SOUND CONTROLLER FOR MINI-COMPONENT STEREO

TIMING DEFINITION OF DIGITAL BLOCK

Symbol	Parameter	Limits			Unit
		Min.	Typ.	Max.	
$t_{cr}$	Clock cycle time	4	-	-	$\mu s$
$t_{WHC}$	Clock pulse width ("H" level)	1.6	-	-	$\mu s$
$t_{WLC}$	Clock pulse width ("L" level)	1.6	-	-	$\mu s$
$t_r$	Rising time of clock, data and latch	-	-	0.4	$\mu s$
$t_f$	Falling time of clock, data and latch	-	-	0.4	$\mu s$
$t_{SD}$	Data setup time	0.8	-	-	$\mu s$
$t_{HD}$	Data hold time	0.8	-	-	$\mu s$
$t_{SL}$	Latch setup time	1	-	-	$\mu s$
$t_{WHL}$	Latch pulse width	1.6	-	-	$\mu s$

CLOCK AND DATA TIMINGS

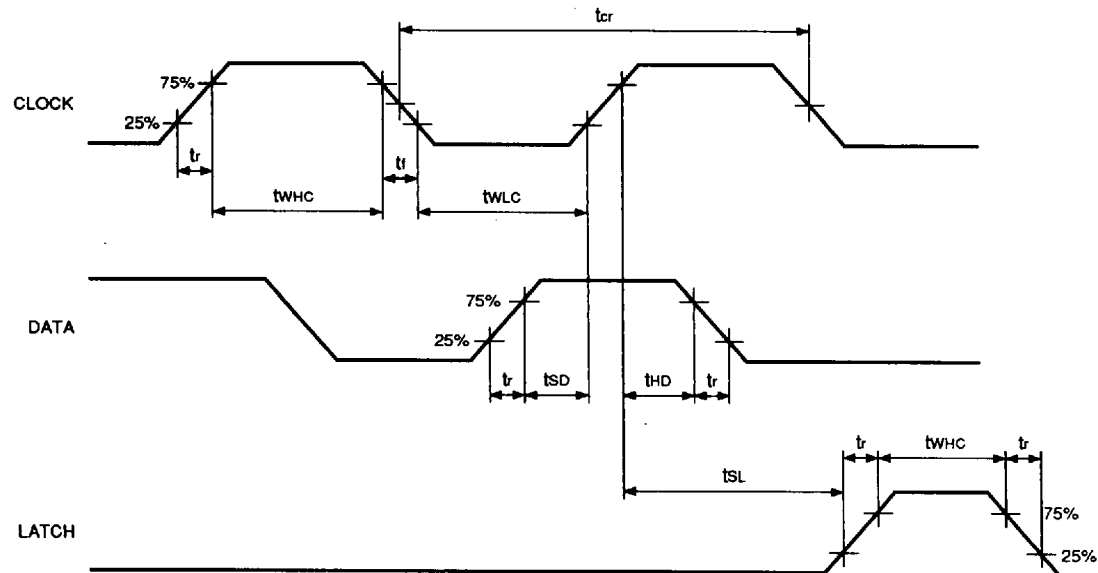

6249826 0022298 678



SOUND QUALITY/SOUND FIELD CONTROL DIGITAL SOUND CONTROLLER FOR MINI-COMPONENT STEREO

FUNCTION DESCRIPTION

(1) Equivalent circuit with vocal cancel

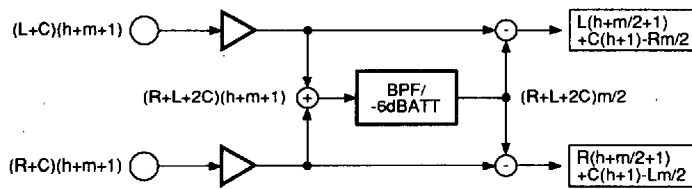

(2) Equivalent circuit with surround

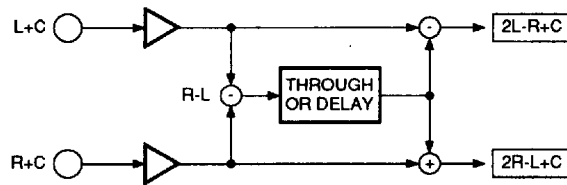

(3) Equivalent circuit with simulated stereo

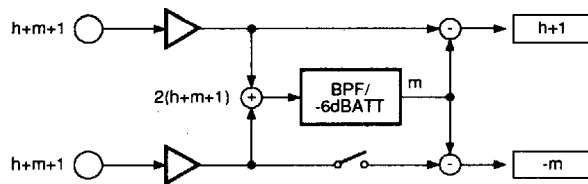

6249826 0022299 504



SOUND QUALITY/SOUND FIELD CONTROL DIGITAL SOUND CONTROLLER FOR MINI-COMPONENT STEREO

(4) Master volume equivalent circuit

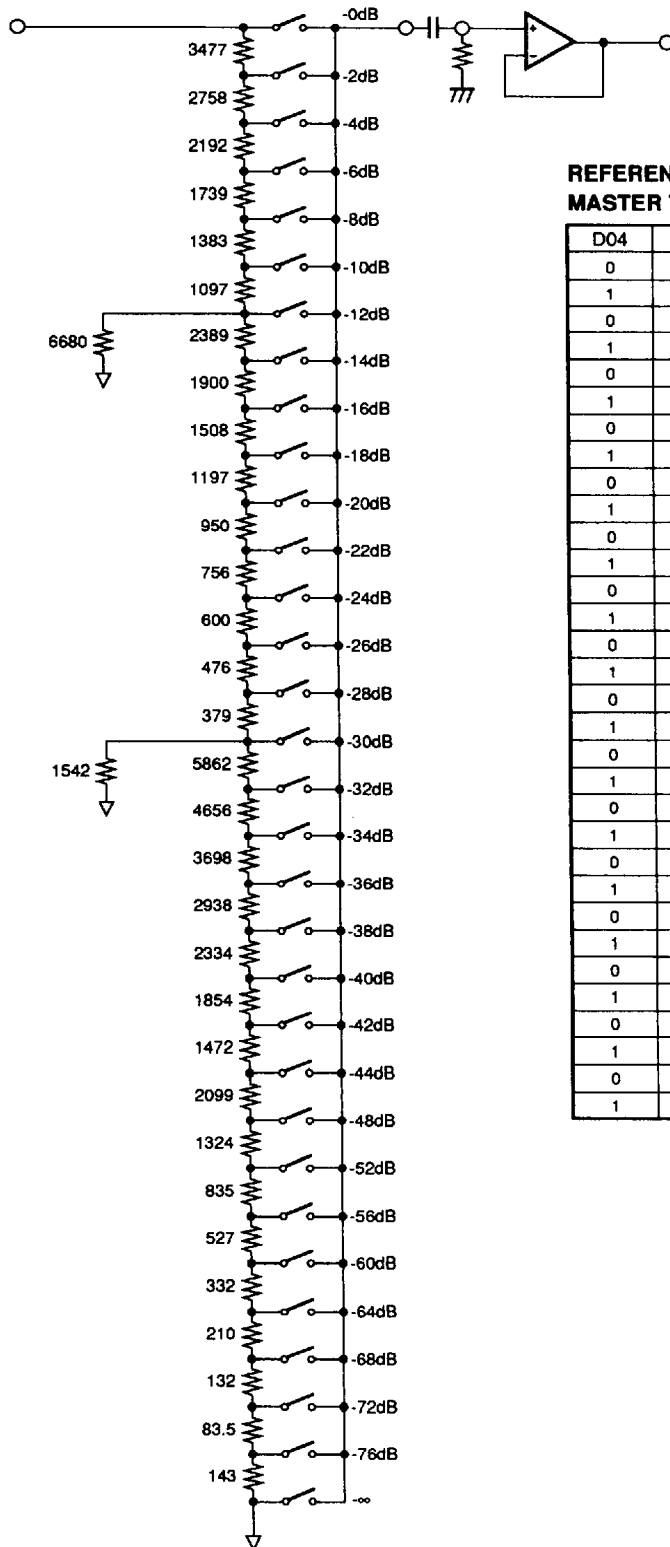

REFERENCE VALUES FOR MASTER VOLUME ATTENUATION

D04	D14	D24	D34	D44	Amount of ATT
0	0	0	0	0	- 0.0dB
1	0	0	0	0	- 2.0dB
0	1	0	0	0	- 4.0dB
1	1	0	0	0	- 6.0dB
0	0	1	0	0	- 8.0dB
1	0	1	0	0	-10.0dB
0	1	1	0	0	-12.0dB
1	1	1	0	0	-14.0dB
0	0	0	1	0	-16.0dB
1	0	0	1	0	-18.0dB
0	1	0	1	0	-20.0dB
1	1	0	1	0	-22.0dB
0	0	1	1	0	-24.0dB
1	0	1	1	0	-26.0dB
0	1	1	1	0	-28.0dB
1	1	1	1	0	-30.0dB
0	0	0	0	1	-32.0dB
1	0	0	0	1	-34.0dB
0	1	0	0	1	-36.0dB
1	1	0	0	1	-38.0dB
0	0	1	0	1	-40.0dB
1	0	1	0	1	-42.0dB
0	1	1	0	1	-44.0dB
1	1	1	0	1	-48.0dB
0	0	0	1	1	-52.0dB
1	0	0	1	1	-56.0dB
0	1	0	1	1	-60.0dB
1	1	0	1	1	-64.0dB
0	0	1	1	1	-68.0dB
1	0	1	1	1	-72.0dB
0	1	1	1	1	-76.0dB
1	1	1	1	1	-∞

6249826 0022300 056



SOUND QUALITY/SOUND FIELD CONTROL DIGITAL SOUND CONTROLLER FOR MINI-COMPONENT STEREO

(5) Equivalent circuit of tone control resonance circuit block

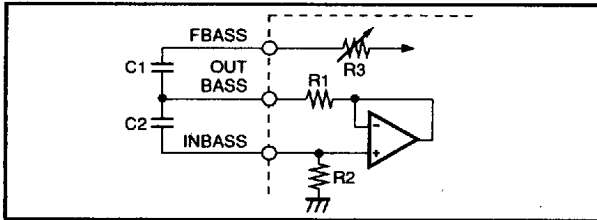

Fig.1 Internal resonance equivalent circuit

Center frequency

$$f_0 = 1/2\pi \sqrt{C1 \cdot C2 \cdot R1 \cdot R2} \text{ (Hz)}$$

$$Q = \sqrt{(C2 \cdot R2) / (C1 \cdot R1)}$$

(Example) Bass band (f=150Hz)

$$R1 = 1.5k\Omega, R2 = 56k\Omega$$

$$C1 = 1.5\mu, C2 = 0.01\mu$$

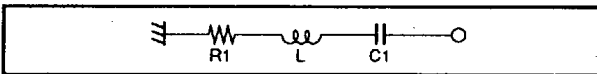

Fig.2 Equivalent circuit using L

Figure 1 means Figure 2 in equivalence. The part constant is converted by the following formula.

$$L = C2 \cdot R1 \cdot R2$$

(6) Equivalent circuit of bass boost circuit block

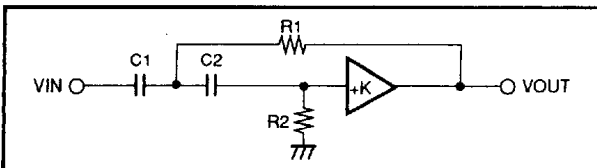
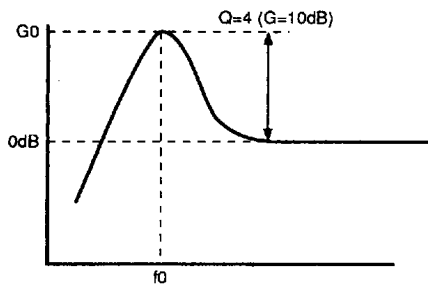
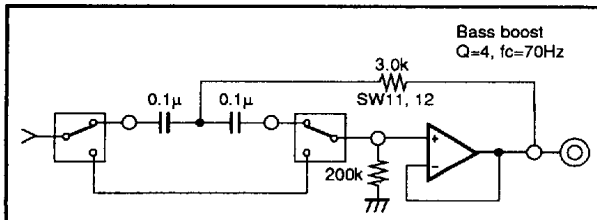

Fig.3 Positive feedback type secondary high pass filter circuit of bass boost block

Amplitude characteristics of secondary high pass filter (for reference)

Q	G0
1	0 to 1dB
2	6 dB
4	10 dB
5	13 dB
10	20 dB

The transmission function is given by the following formula.

$$\frac{V_{OUT}}{V_{IN}} = \frac{Ks^2}{s^2 + s \left[ \frac{1}{R2C1} + \frac{1}{R2C2} + (1-K) \frac{1}{R1C1} \right] + \frac{1}{R1R2C1C2}}$$

$$\omega_0^2 = \frac{1}{R1R2C1C2}$$

$$Q = \frac{1}{\sqrt{\frac{R1C1}{R2C2} + \sqrt{\frac{R1C2}{R2C1} + (1-K) \frac{R2C2}{R1C1}}}}$$

The bass boost block consists of the positive feedback type secondary high pass circuit shown in Figure 3.

A design calculation example of the bass boost block is shown below.

If  $C1=C2=Cf$  and  $K=+1$  are assumed, the following are found with the above formula.

$$Rf = 1/(\omega_0 Cf) \dots \dots \dots (1)$$

$$R1 = Rf/2Q \dots \dots \dots (2)$$

$$R2 = 2QRf \dots \dots \dots (3)$$

If the cut-off frequency is 70Hz, and Q is 4,  $\omega_0 = 2\pi \times 70\text{Hz}$ , and Q=4 are assumed.

With  $C1=C2=Cf=0.1\mu\text{F}$ , R1 and R2 are approximately 3.0kΩ and 200kΩ, respectively, because of (1), (2) and (3).

$$Rf = 22.7k\Omega$$

$$R1 = 2.84k\Omega$$

$$R2 = 182k\Omega$$

(7) Equivalent circuit of band pass filter block

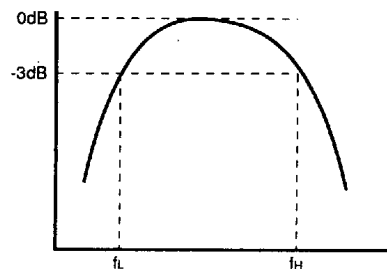
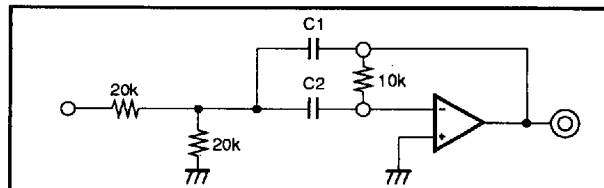

(Band pass filter design formula)

$$f_H \text{ (Cut-off frequency at side H)} = \frac{1}{2\pi C1 \cdot 10k}$$

$$f_L \text{ (Cut-off frequency at side L)} = \frac{1}{2\pi C2 \cdot 10k}$$

6249826 0022301 T92



SOUND QUALITY/SOUND FIELD CONTROL DIGITAL SOUND CONTROLLER FOR MINI-COMPONENT STEREO

SIGNAL TRANSMISSION BLOCK DIAGRAM (1)

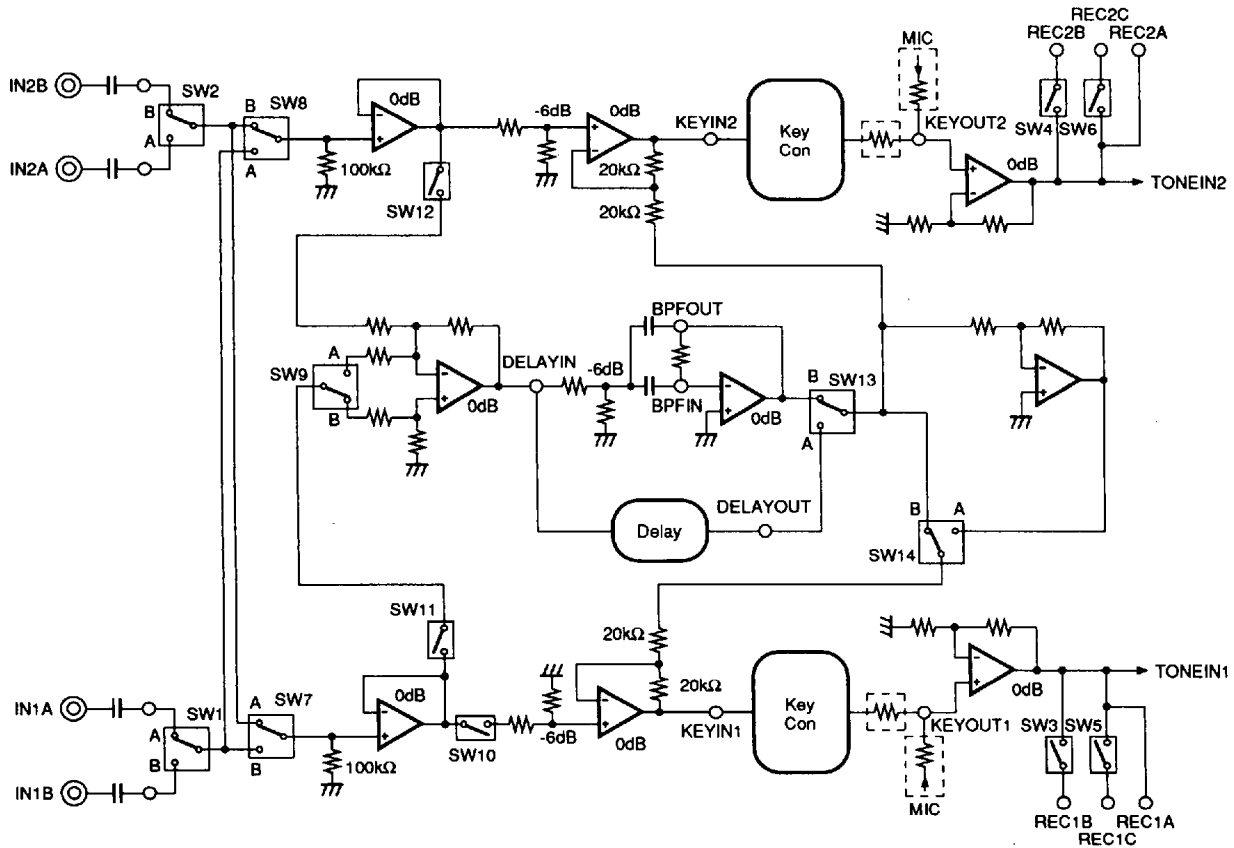

SIGNAL TRANSMISSION BLOCK DIAGRAM (2)

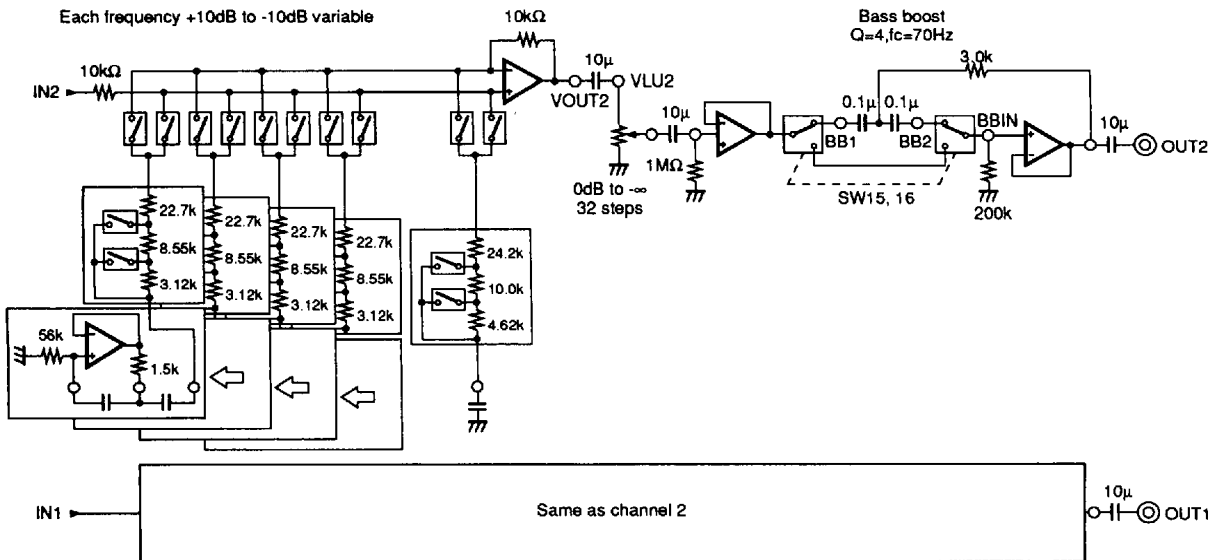

6249826 0022302 929



SOUND QUALITY/SOUND FIELD CONTROL DIGITAL SOUND CONTROLLER FOR MINI-COMPONENT STEREO

TEST CIRCUIT

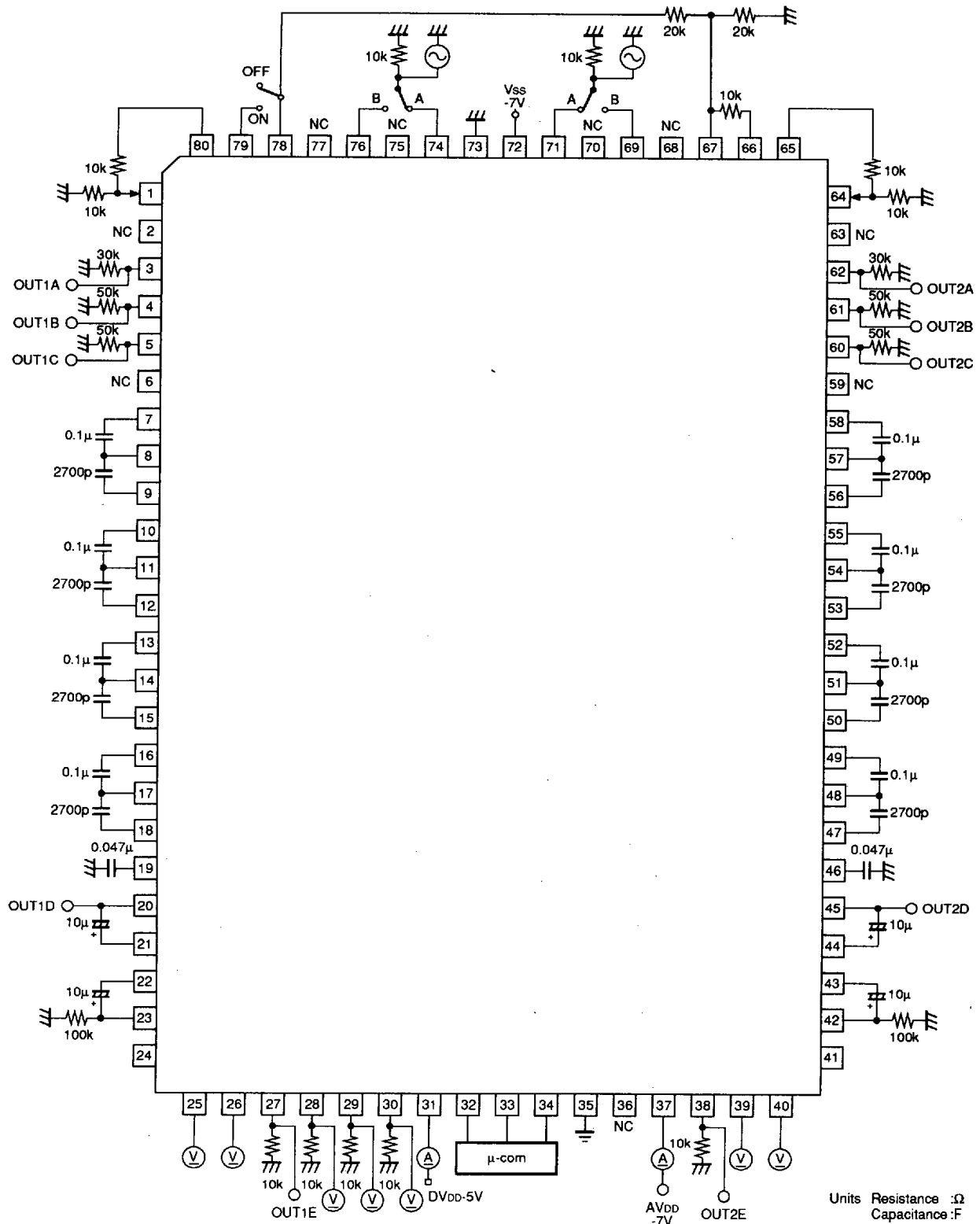

6249826 0022303 865