

QUAD BUS BUFFERS (3-STATE)

- HIGH SPEED
 $t_{PD} = 8 \text{ ns}$ (TYP.) AT $V_{CC} = 5 \text{ V}$
- LOW POWER DISSIPATION
 $I_{CC} = 4 \mu\text{A}$ (MAX.) AT 25°C
- OUTPUT DRIVE CAPABILITY
 15 LSTTL LOADS
- BALANCED PROPAGATION DELAYS
 $t_{PLH} = t_{PHL}$
- SYMMETRICAL OUTPUT IMPEDANCE
 $I_{OL} = |I_{OH}| = 6 \text{ mA}$ (MIN.)
- HIGH NOISE IMMUNITY
 $V_{NIH} = V_{NIL} = 28\% V_{CC}$ (MIN.)
- WIDE OPERATING VOLTAGE RANGE
 $V_{CC} \text{ (OPR)} = 2 \text{ V TO } 6 \text{ V}$
- PIN AND FUNCTION COMPATIBLE
 WITH 54/74LS125/126

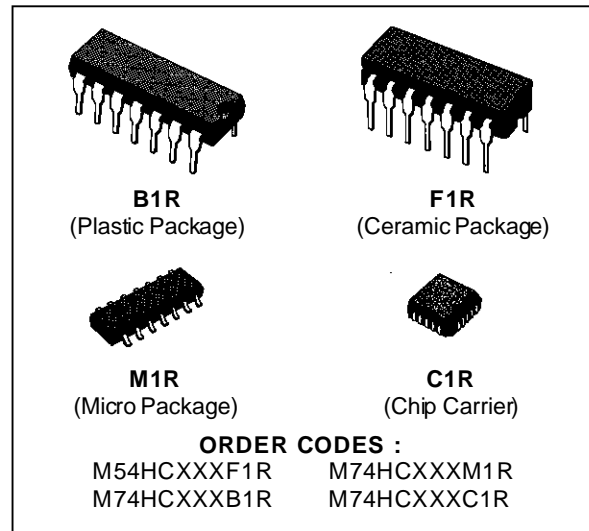

DESCRIPTION

The M54/74HC125/126 are high speed CMOS QUAD BUS BUFFER (3-STATE) FABRICATED IN SILICON GATE C²MOS technology.

They have the same high speed performance of LSTTL combined with true CMOS low power consumption.

These devices require the same 3-STATE control input G to be taken high to make the output go into the high impedance state.

All inputs are equipped with protection circuits against static discharge and transient excess voltage.

INPUT AND OUTPUT EQUIVALENT CIRCUIT

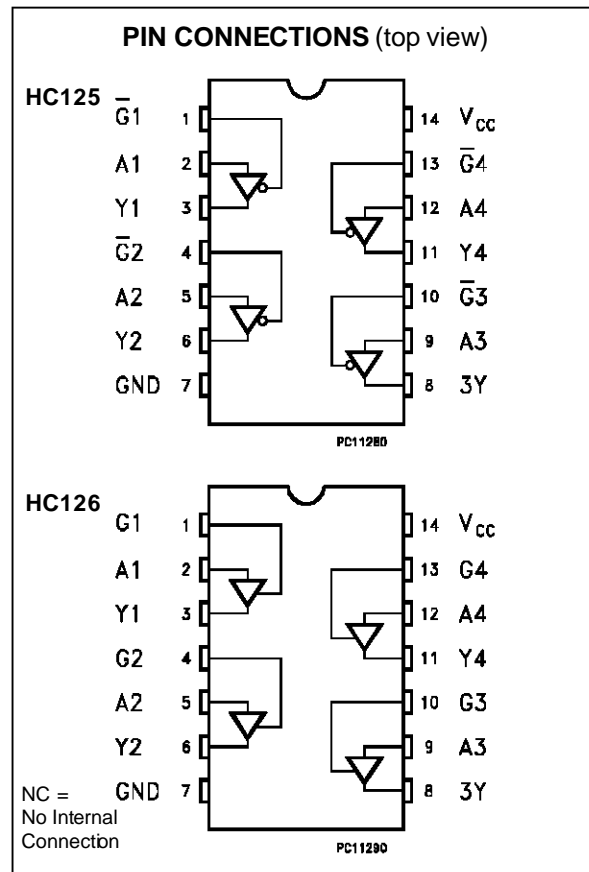
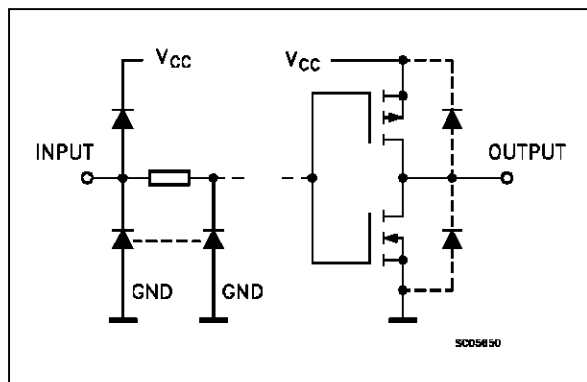

CHIP CARRIER

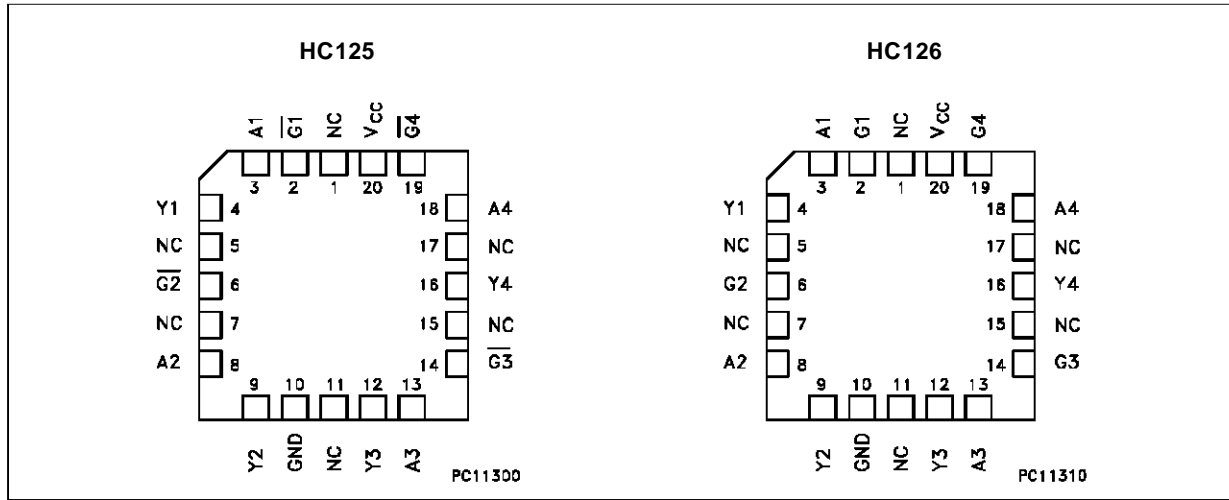

TRUTH TABLE (HC125)

A	\overline{G}	Y
X	H	Z
L	L	L
H	L	H

TRUTH TABLE (HC126)

A	G	Y
X	L	Z
L	H	L
H	H	H

PIN DESCRIPTION (HC125)

PIN No	SYMBOL	NAME AND FUNCTION
1, 4, 10, 13	$\overline{G1}$ to $\overline{G4}$	Output Enable Input
2, 5, 9, 12	A1 to A4	Data Inputs
3, 6, 8, 11	Y1 to Y4	Data Outputs
7	GND	Ground (0V)
14	V _{cc}	Positive Supply Voltage

PIN DESCRIPTION (HC126)

PIN No	SYMBOL	NAME AND FUNCTION
1, 4, 10, 13	G1 to G4	Output Enable Input
2, 5, 9, 12	A1 to A4	Data Inputs
3, 6, 8, 11	Y1 to Y4	Data Outputs
7	GND	Ground (0V)
14	V _{cc}	Positive Supply Voltage

IEC LOGIC SYMBOLS

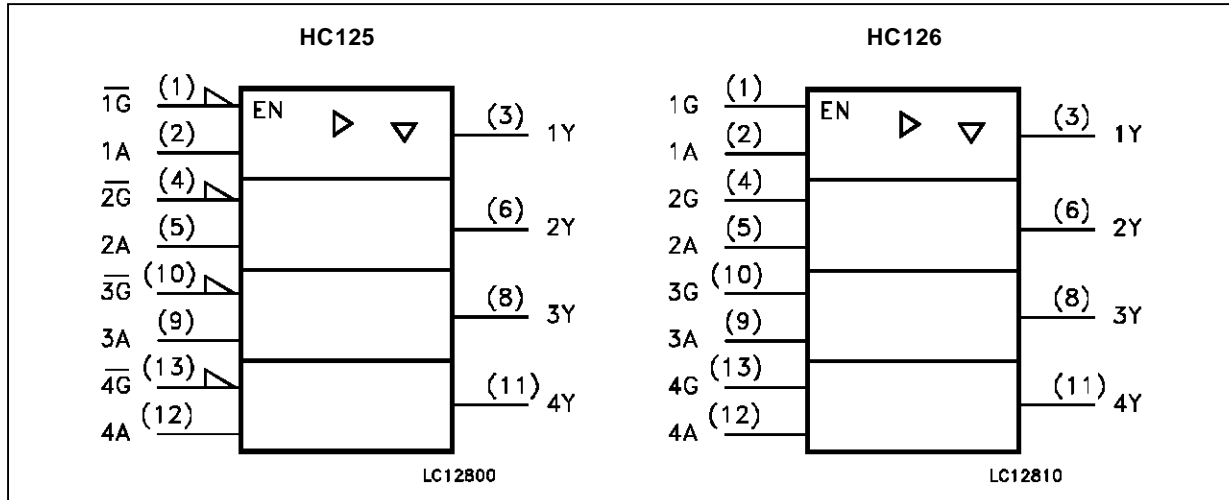

CIRCUIT DIAGRAM

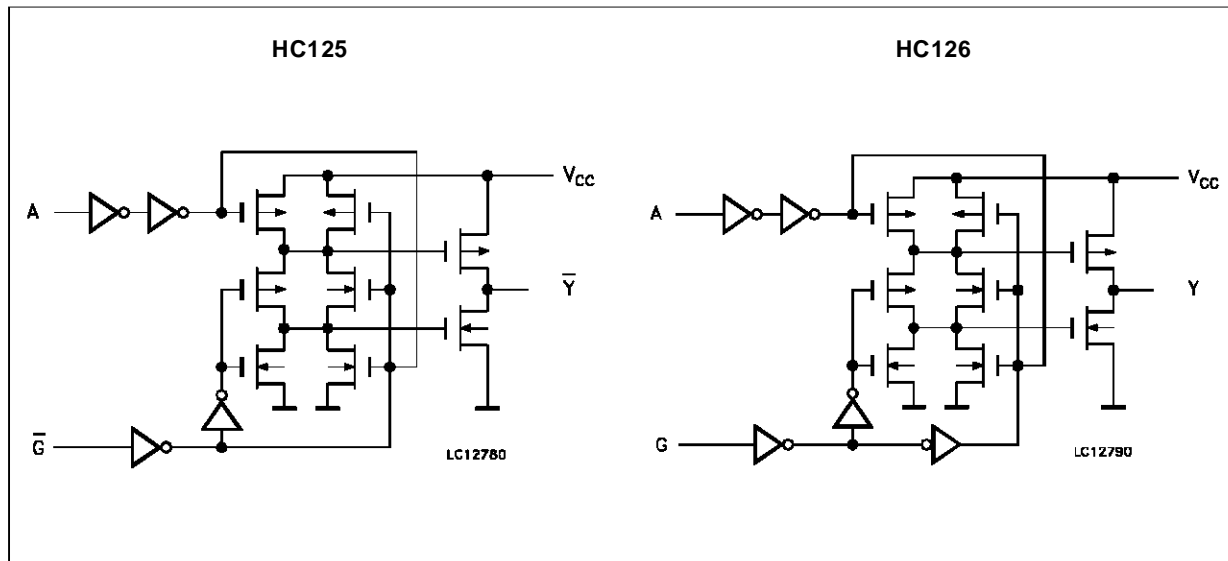

ABSOLUTE MAXIMUM RATINGS

Symbol	Parameter	Value	Unit
V_{CC}	Supply Voltage	-0.5 to +7	V
V_I	DC Input Voltage	-0.5 to $V_{CC} + 0.5$	V
V_O	DC Output Voltage	-0.5 to $V_{CC} + 0.5$	V
I_{IK}	DC Input Diode Current	± 20	mA
I_{OK}	DC Output Diode Current	± 20	mA
I_O	DC Output Source Sink Current Per Output Pin	± 35	mA
I_{CC} or I_{GND}	DC V_{CC} or Ground Current	± 70	mA
P_D	Power Dissipation	500 (*)	mW
T_{stg}	Storage Temperature	-65 to +150	$^{\circ}C$
T_L	Lead Temperature (10 sec)	300	$^{\circ}C$

Absolute Maximum Ratings are those values beyond which damage to the device may occur. Functional operation under these condition is not implied.
 (*) 500 mW: $\cong 65^{\circ}C$ derate to 300 mW by 10mW/ $^{\circ}C$: $65^{\circ}C$ to $85^{\circ}C$

RECOMMENDED OPERATING CONDITIONS

Symbol	Parameter	Value	Unit
V_{CC}	Supply Voltage	2 to 6	V
V_I	Input Voltage	0 to V_{CC}	V
V_O	Output Voltage	0 to V_{CC}	V
T_{op}	Operating Temperature: M54HC Series M74HC Series	-55 to +125 -40 to +85	$^{\circ}C$ $^{\circ}C$
t_r, t_f	Input Rise and Fall Time	$V_{CC} = 2 V$	0 to 1000
		$V_{CC} = 4.5 V$	0 to 500
		$V_{CC} = 6 V$	0 to 400

DC SPECIFICATIONS

Symbol	Parameter	Test Conditions		Value						Unit		
		V _{CC} (V)		T _A = 25 °C 54HC and 74HC			-40 to 85 °C 74HC		-55 to 125 °C 54HC			
				Min.	Typ.	Max.	Min.	Max.	Min.		Max.	
V _{IH}	High Level Input Voltage	2.0		1.5			1.5		1.5		V	
		4.5		3.15			3.15		3.15			
		6.0		4.2			4.2		4.2			
V _{IL}	Low Level Input Voltage	2.0				0.5		0.5		0.5	V	
		4.5				1.35		1.35		1.35		
		6.0				1.8		1.8		1.8		
V _{OH}	High Level Output Voltage	2.0	V _I = V _{IH} or V _{IL}	I _O = -20 μA	1.9	2.0		1.9		1.9	V	
		4.5			4.4	4.5		4.4		4.4		
		6.0			5.9	6.0		5.9		5.9		
		4.5	I _O = -6.0 mA	4.18	4.31		4.13		4.10			
		6.0		I _O = -7.8 mA	5.68	5.8		5.63		5.60		
V _{OL}	Low Level Output Voltage	2.0	V _I = V _{IH} or V _{IL}	I _O = 20 μA		0.0	0.1		0.1		V	
		4.5				0.0	0.1		0.1			0.1
		6.0				0.0	0.1		0.1			0.1
		4.5	I _O = 6.0 mA		0.17	0.26		0.33		0.40		
		6.0		I _O = 7.8 mA		0.18	0.26		0.33			0.40
I _I	Input Leakage Current	6.0	V _I = V _{CC} or GND			±0.1		±1		±1	μA	
I _{OZ}	3 State Output Off-state Current	6.0	V _I = V _{IH} or V _{IL} V _O = V _{CC} or GND			±0.5		±5		±10	μA	
I _{CC}	Quiescent Supply Current	6.0	V _I = V _{CC} or GND			4		40		80	μA	

AC ELECTRICAL CHARACTERISTICS (Input $t_r = t_f = 6$ ns)

Symbol	Parameter	Test Conditions			Value						Unit						
		V _{CC} (V)	C _L (pF)		T _A = 25 °C 54HC and 74HC			-40 to 85 °C 74HC		-55 to 125 °C 54HC							
					Min.	Typ.	Max.	Min.	Max.	Min.		Max.					
t _{TLH} t _{THL}	Output Transition Time	2.0 4.5 6.0	50			20 6 5	60 12 10		75 15 13		90 18 15	ns					
t _{PLH} t _{PHL}	Propagation Delay Time	2.0 4.5 6.0		50			36 9 8	75 15 13		95 19 16			110 22 19	ns			
		2.0 4.5 6.0			150			52 13 11	105 21 18		130 26 22				160 32 27	ns	
		t _{PZL} t _{PZH}	3 State Output Enable Time			2.0 4.5 6.0	50	R _L = 1 KΩ			36 9 8	75 15 13			95 19 16		
2.0 4.5 6.0	150			R _L = 1 KΩ						52 13 11	105 21 18		130 26 22		160 32 27		ns
t _{PLZ} t _{PHZ}					3 State Output Disable Time	2.0 4.5 6.0			50	R _L = 1 KΩ			48 12 10	80 16 14		100 20 17	
		C _{IN}	Input Capacitance														
	C _{PD} (*)	Power Dissipation Capacitance															pF

(*) C_{PD} is defined as the value of the IC's internal equivalent capacitance which is calculated from the operating current consumption without load. (Refer to Test Circuit). Average operating current can be obtained by the following equation. $I_{cc(opr)} = C_{PD} \cdot V_{CC} \cdot f_{IN} + I_{cc}$

SWITCHING CHARACTERISTICS TEST WAVEFORM

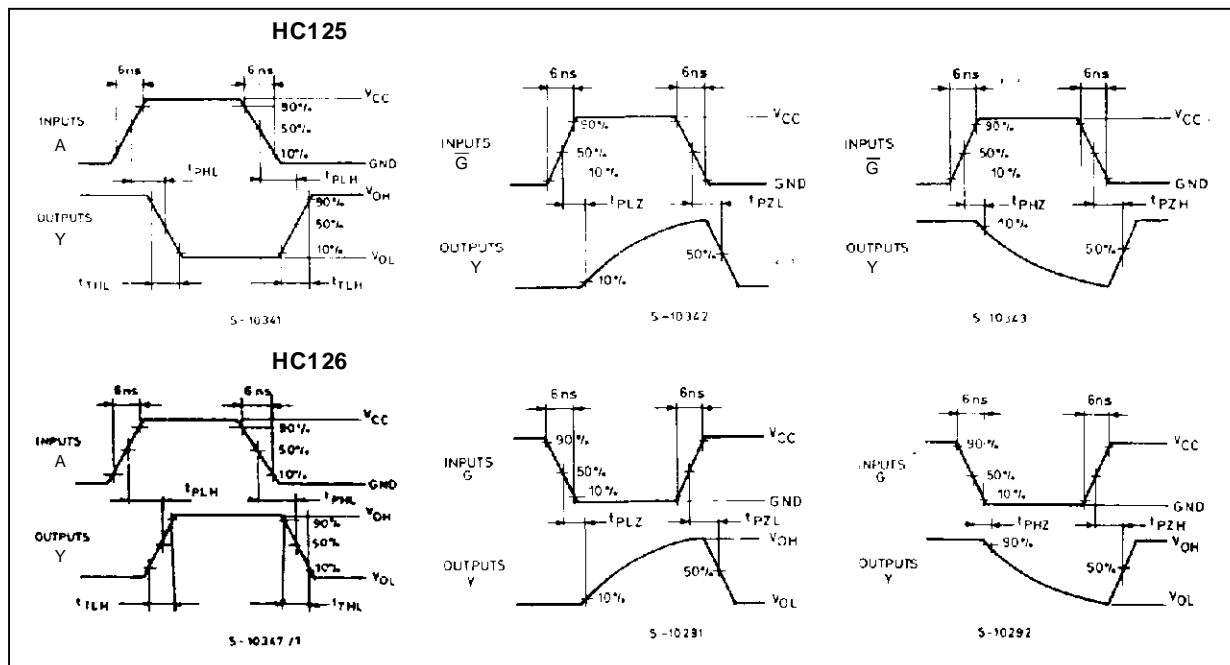

TEST CIRCUIT I_{CC} (Opr.)

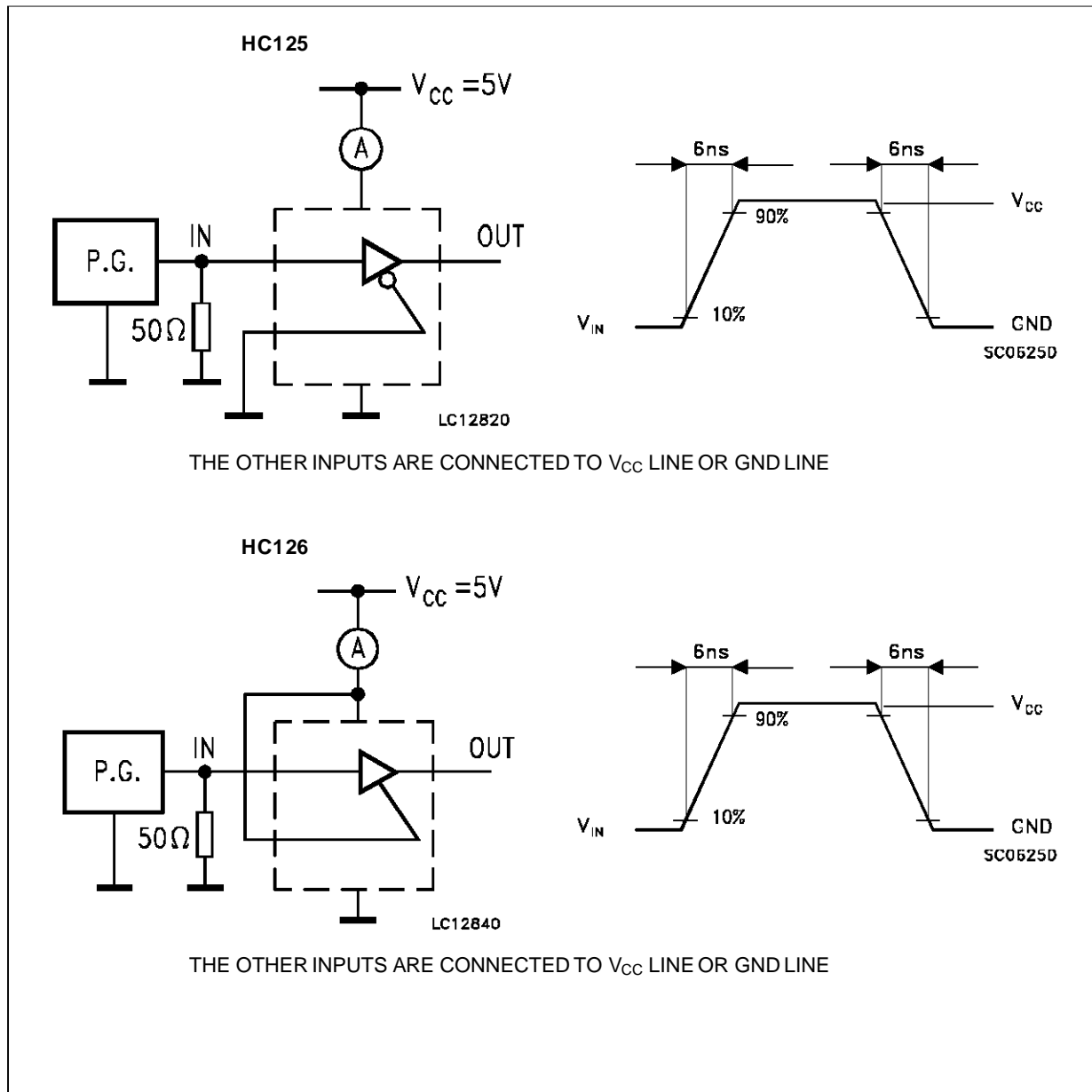

Plastic DIP14 MECHANICAL DATA

DIM.	mm			inch		
	MIN.	TYP.	MAX.	MIN.	TYP.	MAX.
a1	0.51			0.020		
B	1.39		1.65	0.055		0.065
b		0.5			0.020	
b1		0.25			0.010	
D			20			0.787
E		8.5			0.335	
e		2.54			0.100	
e3		15.24			0.600	
F			7.1			0.280
I			5.1			0.201
L		3.3			0.130	
Z	1.27		2.54	0.050		0.100

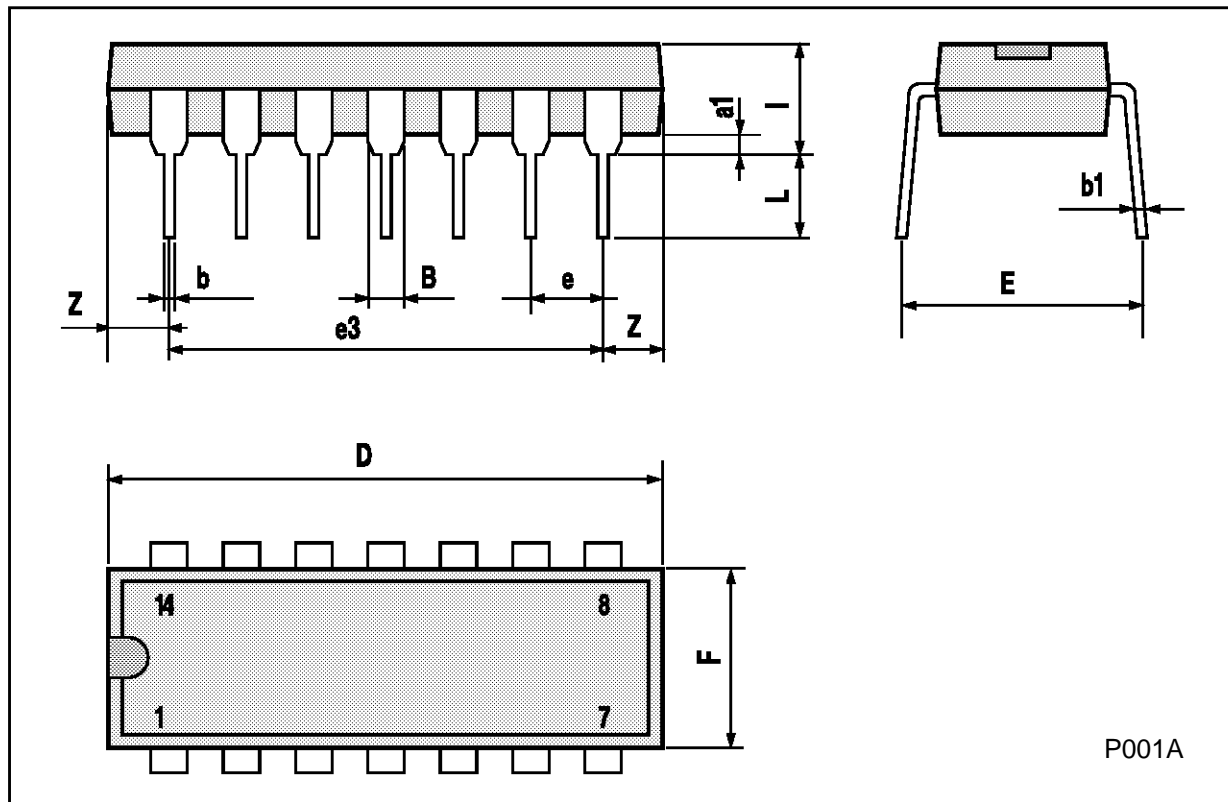

P001A

Ceramic DIP14/1 MECHANICAL DATA

DIM.	mm			inch		
	MIN.	TYP.	MAX.	MIN.	TYP.	MAX.
A			20			0.787
B			7.0			0.276
D		3.3			0.130	
E	0.38			0.015		
e3		15.24			0.600	
F	2.29		2.79	0.090		0.110
G	0.4		0.55	0.016		0.022
H	1.17		1.52	0.046		0.060
L	0.22		0.31	0.009		0.012
M	1.52		2.54	0.060		0.100
N			10.3			0.406
P	7.8		8.05	0.307		0.317
Q			5.08			0.200

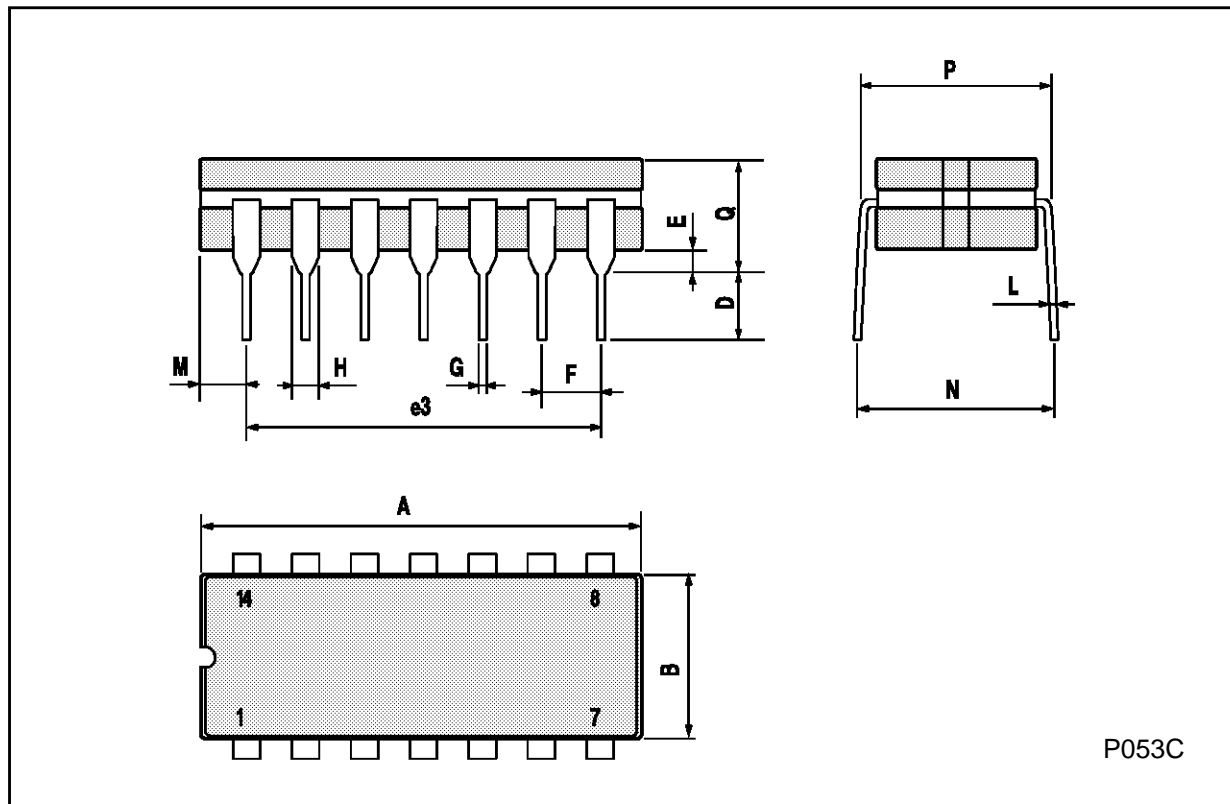

P053C

SO14 MECHANICAL DATA

DIM.	mm			inch		
	MIN.	TYP.	MAX.	MIN.	TYP.	MAX.
A			1.75			0.068
a1	0.1		0.2	0.003		0.007
a2			1.65			0.064
b	0.35		0.46	0.013		0.018
b1	0.19		0.25	0.007		0.010
C		0.5			0.019	
c1	45° (typ.)					
D	8.55		8.75	0.336		0.344
E	5.8		6.2	0.228		0.244
e		1.27			0.050	
e3		7.62			0.300	
F	3.8		4.0	0.149		0.157
G	4.6		5.3	0.181		0.208
L	0.5		1.27	0.019		0.050
M			0.68			0.026
S	8° (max.)					

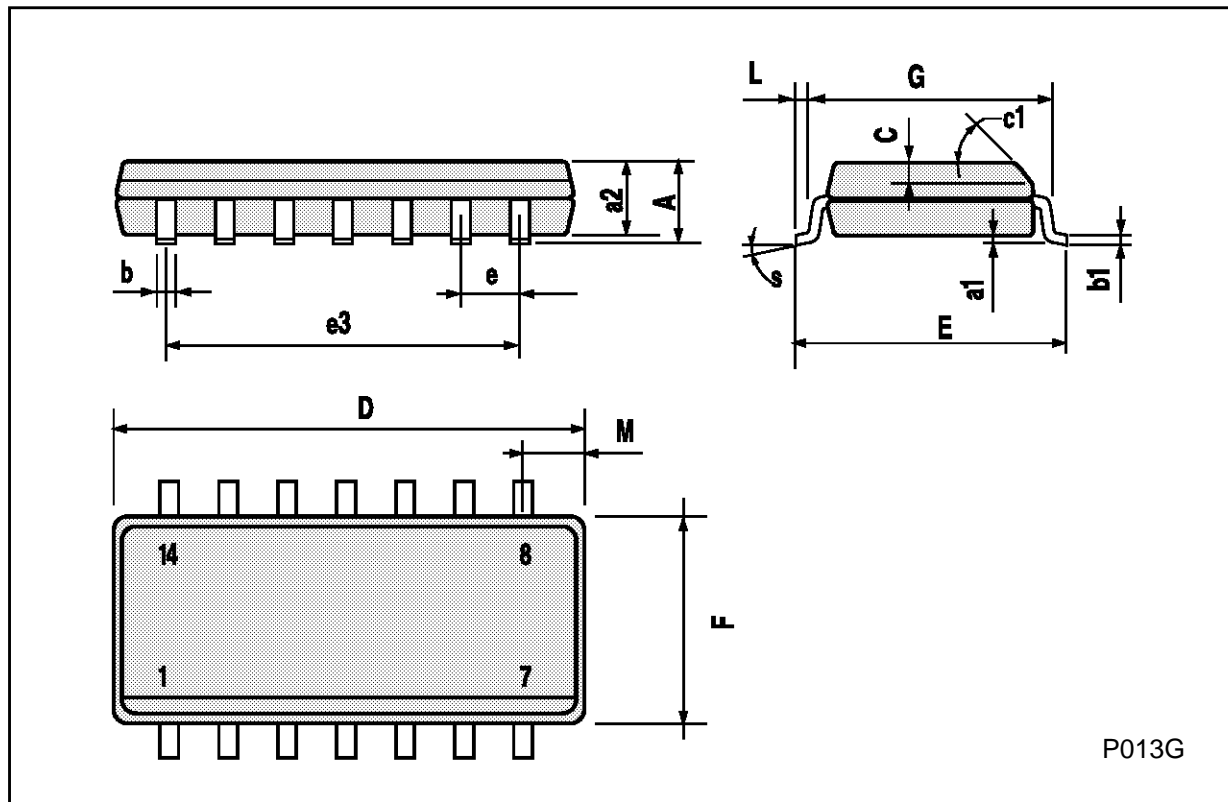

PLCC20 MECHANICAL DATA

DIM.	mm			inch		
	MIN.	TYP.	MAX.	MIN.	TYP.	MAX.
A	9.78		10.03	0.385		0.395
B	8.89		9.04	0.350		0.356
D	4.2		4.57	0.165		0.180
d1		2.54			0.100	
d2		0.56			0.022	
E	7.37		8.38	0.290		0.330
e		1.27			0.050	
e3		5.08			0.200	
F		0.38			0.015	
G			0.101			0.004
M		1.27			0.050	
M1		1.14			0.045	



Information furnished is believed to be accurate and reliable. However, SGS-THOMSON Microelectronics assumes no responsibility for the consequences of use of such information nor for any infringement of patents or other rights of third parties which may result from its use. No license is granted by implication or otherwise under any patent or patent rights of SGS-THOMSON Microelectronics. Specifications mentioned in this publication are subject to change without notice. This publication supersedes and replaces all information previously supplied. SGS-THOMSON Microelectronics products are not authorized for use as critical components in life support devices or systems without express written approval of SGS-THOMSON Microelectronics.

© 1994 SGS-THOMSON Microelectronics - All Rights Reserved

SGS-THOMSON Microelectronics GROUP OF COMPANIES

Australia - Brazil - France - Germany - Hong Kong - Italy - Japan - Korea - Malaysia - Malta - Morocco - The Netherlands -
Singapore - Spain - Sweden - Switzerland - Taiwan - Thailand - United Kingdom - U.S.A