

4 TO 16 LINE DECODER/DEMULTIPLEXER

- HIGH SPEED
- $t_{PD} = 15 \text{ ns}$ (TYP.) at $V_{CC} = 5 \text{ V}$
- LOW POWER DISSIPATION
 $I_{CC} = 4 \mu\text{A}$ (MAX.) at $T_A = 25 \text{ }^\circ\text{C}$
- HIGH NOISE IMMUNITY
 $V_{NIH} = V_{NIL} = 28 \% V_{CC}$ (MIN.)
- OUTPUT DRIVE CAPABILITY
15 LSTTL LOADS
- SYMMETRICAL OUTPUT IMPEDANCE
 $|I_{OH}| = I_{OL} = 4 \text{ mA}$ (MIN.)
- BALANCED PROPAGATION DELAYS
 $t_{PLH} = t_{PHL}$
- WIDE OPERATING VOLTAGE RANGE
 V_{CC} (OPR) = 2 V to 6 V
- PIN AND FUNCTION COMPATIBLE
WITH 54/74LS154

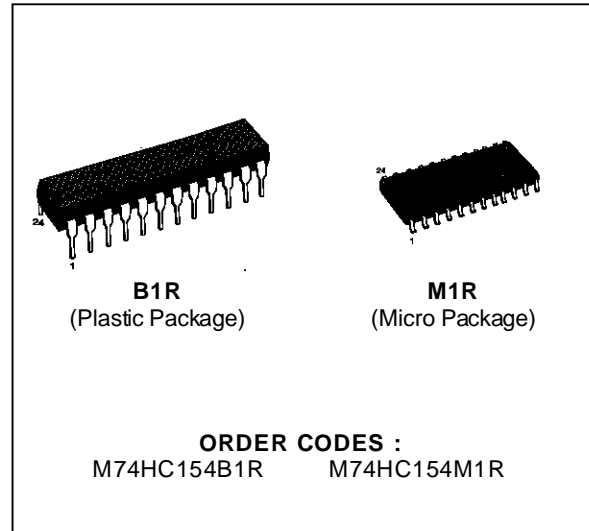

DESCRIPTION

The 74HC154 is a high speed CMOS 4 TO 16-LINE DECODER/DEMULTIPLEXER fabricated in silicon gate CMOS technology. It has the same high speed performance of LSTTL combined with true CMOS low power consumption.

A binary code applied to the four inputs (A to D) provides a low level at the selected one of sixteen outputs excluding the other fifteen outputs, when both the strobe inputs, G1 and G2, are held low. When either strobe input is held high, the decoding function is inhibited to keep all outputs high. The strobe function makes it easy to expand the decoding lines through cascading, and simplifies the design of address decoding circuits in memory control systems.

All inputs are equipped with protection circuits against static discharge and transient excess voltage.

PIN CONNECTIONS (top view)

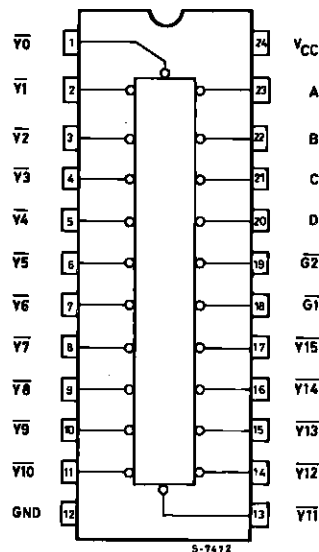

NC =
No Internal
Connection

M74HC154

TRUTH TABLE

INPUTS						SELECTED OUTPUT (L)
$\overline{G1}$	$\overline{G2}$	D	C	B	A	
L	L	L	L	L	L	$\overline{Y0}$
L	L	L	L	L	H	$\overline{Y1}$
L	L	L	L	H	L	$\overline{Y2}$
L	L	L	L	H	H	$\overline{Y3}$
L	L	L	H	L	L	$\overline{Y4}$
L	L	L	H	L	H	$\overline{Y5}$
L	L	L	H	H	L	$\overline{Y6}$
L	L	L	H	H	H	$\overline{Y7}$
L	L	H	L	L	L	$\overline{Y8}$
L	L	H	L	L	H	$\overline{Y9}$
L	L	H	L	H	L	$\overline{Y10}$
L	L	H	L	H	H	$\overline{Y11}$
L	L	H	H	L	L	$\overline{Y12}$
L	L	H	H	L	H	$\overline{Y13}$
L	L	H	H	H	L	$\overline{Y14}$
L	L	H	H	H	H	$\overline{Y15}$
X	H	X	X	X	X	NONE
H	X	X	X	X	X	NONE

X: Don't Care

LOGIC DIAGRAM

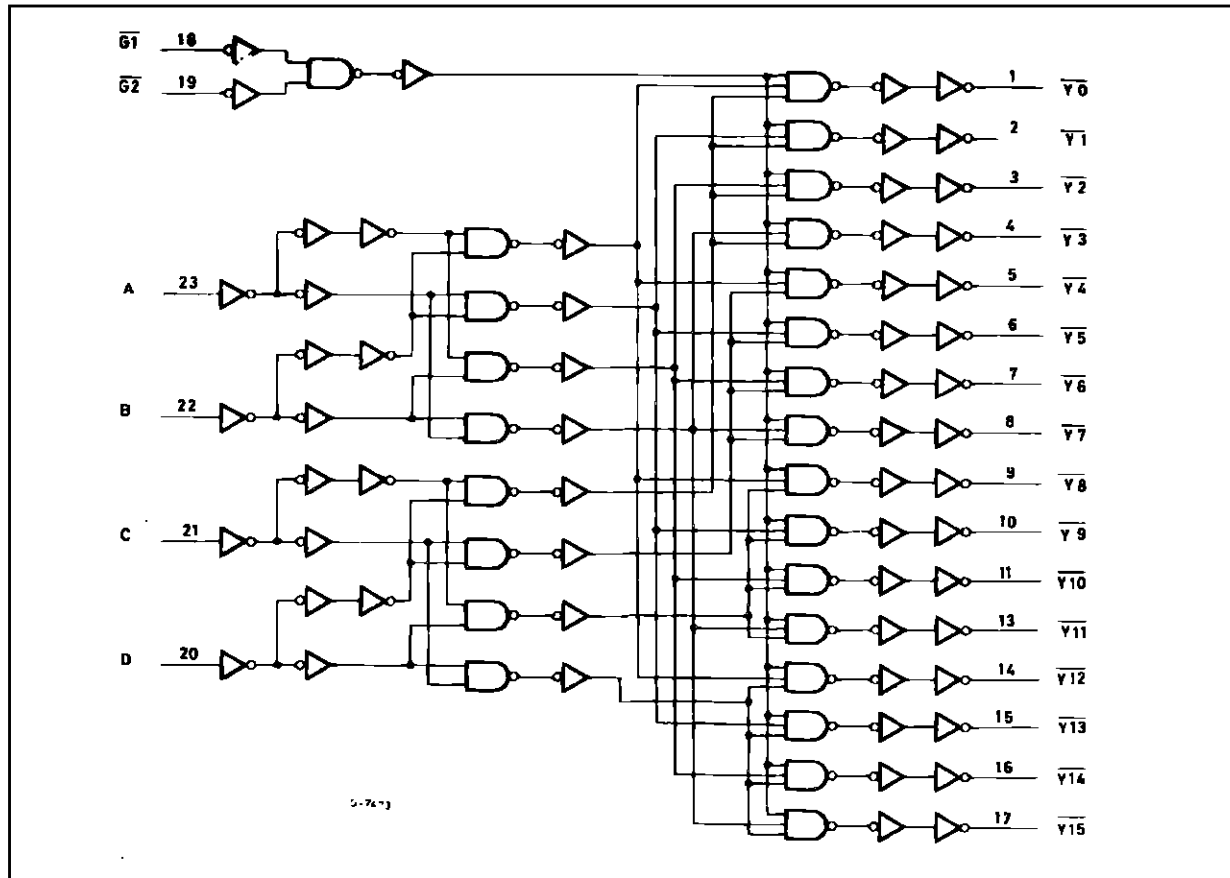

INPUT AND OUTPUT EQUIVALENT CIRCUIT

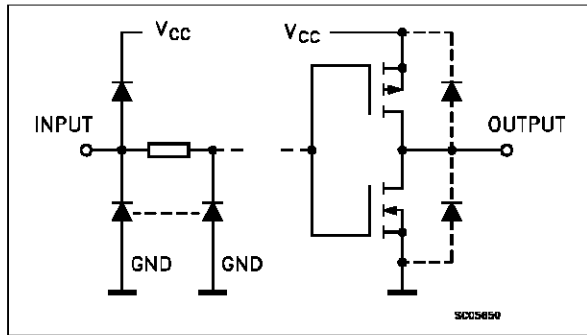

PIN DESCRIPTION

PIN No	SYMBOL	NAME AND FUNCTION
1, 2, 3, 4, 5, 6, 7, 8, 9, 10, 11, 13, 14, 15, 16, 17	$\bar{Y}0$ to $\bar{Y}15$	Outputs (Active LOW)
18, 19	$\bar{G}1, \bar{G}2$	Enable Inputs (Active LOW)
23, 22, 21, 20	A to D	Address Inputs
12	GND	Ground (0V)
24	Vcc	Positive Supply Voltage

IEC LOGIC SYMBOLS

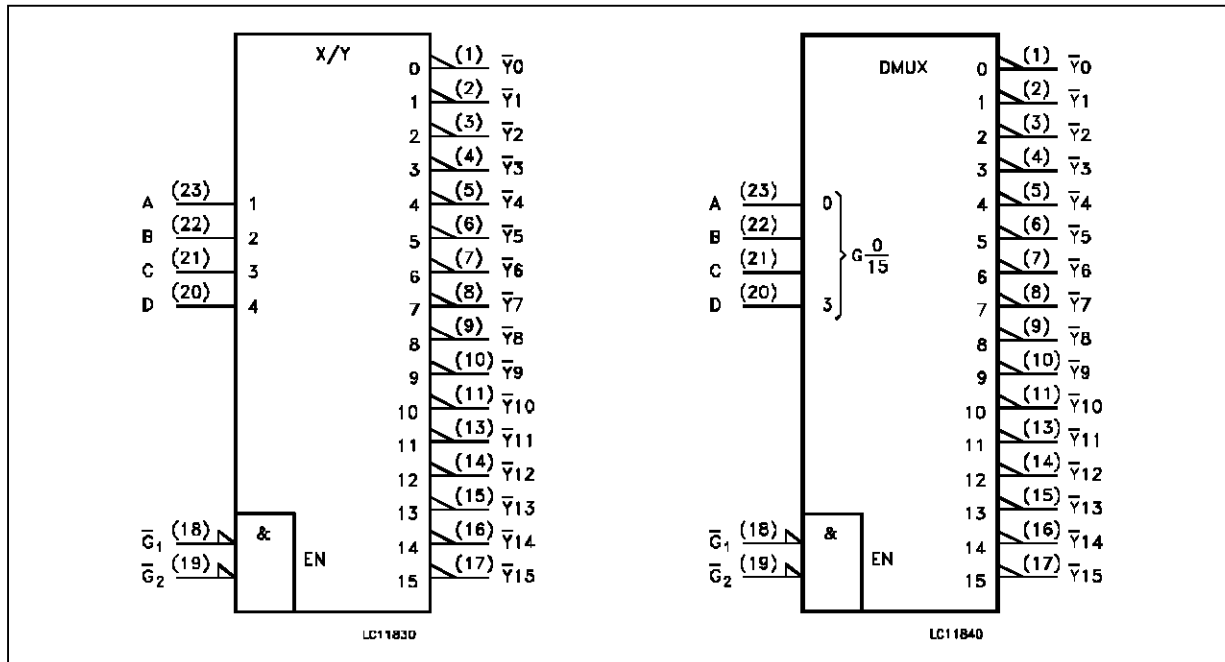

ABSOLUTE MAXIMUM RATINGS

Symbol	Parameter	Value	Unit
V _{CC}	Supply Voltage	-0.5 to +7	V
V _I	DC Input Voltage	-0.5 to V _{CC} + 0.5	V
V _O	DC Output Voltage	-0.5 to V _{CC} + 0.5	V
I _{IK}	DC Input Diode Current	± 20	mA
I _{OK}	DC Output Diode Current	± 20	mA
I _O	DC Output Source Sink Current Per Output Pin	± 25	mA
I _{CC} or I _{GND}	DC V _{CC} or Ground Current	± 50	mA
P _D	Power Dissipation	500 (*)	mW
T _{stg}	Storage Temperature	-65 to +150	°C
T _L	Lead Temperature (10 sec)	300	°C

Absolute Maximum Ratings are those values beyond which damage to the device may occur. Functional operation under these condition is not implied.
 (*) 500 mW: ≅ 65 °C derate to 300 mW by 10mW/°C: 65 °C to 85 °C

M74HC154

RECOMMENDED OPERATING CONDITIONS

Symbol	Parameter	Value	Unit
V_{CC}	Supply Voltage	2 to 6	V
V_I	Input Voltage	0 to V_{CC}	V
V_O	Output Voltage	0 to V_{CC}	V
T_{op}	Operating Temperature:	-40 to +85	°C
t_r, t_f	Input Rise and Fall Time	$V_{CC} = 2\text{ V}$	0 to 1000
		$V_{CC} = 4.5\text{ V}$	0 to 500
		$V_{CC} = 6\text{ V}$	0 to 400

DC SPECIFICATIONS

Symbol	Parameter	Test Conditions		Value					Unit	
		V_{CC} (V)		$T_A = 25\text{ °C}$			$-40\text{ to }85\text{ °C}$			
				Min.	Typ.	Max.	Min.	Max.		
V_{IH}	High Level Input Voltage	2.0		1.5			1.5		V	
		4.5		3.15			3.15			
		6.0		4.2			4.2			
V_{IL}	Low Level Input Voltage	2.0				0.5		0.5	V	
		4.5				1.35		1.35		
		6.0				1.8		1.8		
V_{OH}	High Level Output Voltage	2.0	$V_I = V_{IH}$ or V_{IL}	$I_O = -20\text{ }\mu\text{A}$	1.9	2.0		1.9	V	
		4.5			4.4	4.5		4.4		
		6.0			5.9	6.0		5.9		
		4.5	$I_O = -4.0\text{ mA}$	4.18	4.31		4.13			
		6.0		$I_O = -5.2\text{ mA}$	5.68	5.8		5.63		
V_{OL}	Low Level Output Voltage	2.0	$V_I = V_{IH}$ or V_{IL}	$I_O = 20\text{ }\mu\text{A}$		0.0	0.1	0.1	V	
		4.5				0.0	0.1	0.1		
		6.0				0.0	0.1	0.1		
		4.5			$I_O = 4.0\text{ mA}$	0.17	0.26			0.33
		6.0				$I_O = 5.2\text{ mA}$	0.18	0.26		
I_I	Input Leakage Current	6.0	$V_I = V_{CC}$ or GND			± 0.1		± 1	μA	
I_{CC}	Quiescent Supply Current	6.0	$V_I = V_{CC}$ or GND			4		40	μA	

AC ELECTRICAL CHARACTERISTICS ($C_L = 50 \text{ pF}$, Input $t_r = t_f = 6 \text{ ns}$)

Symbol	Parameter	Test Conditions		Value					Unit
		V_{CC} (V)		$T_A = 25 \text{ }^\circ\text{C}$			$-40 \text{ to } 85 \text{ }^\circ\text{C}$		
				Min.	Typ.	Max.	Min.	Max.	
t_{TLH} t_{THL}	Output Transition Time	2.0			30	75		95	ns
		4.5			8	15		19	
		6.0			7	13		16	
t_{PLH} t_{PHL}	Propagation Delay Time (A, B, C, D - Y)	2.0			65	175		220	ns
		4.5			19	35		44	
		6.0			16	30		37	
t_{PLH} t_{PHL}	Propagation Delay Time (G1, G2 - Y)	2.0			55	160		200	ns
		4.5			17	32		40	
		6.0			15	27		34	
C_{IN}	Input Capacitance				5	10		10	pF
$C_{PD} (*)$	Power Dissipation Capacitance				57				pF

(*) C_{PD} is defined as the value of the IC's internal equivalent capacitance which is calculated from the operating current consumption without load. (Refer to Test Circuit). Average operating current can be obtained by the following equation. $I_{CC(opr)} = C_{PD} \cdot V_{CC} \cdot f_{IN} + I_{CC}$

SWITCHING CHARACTERISTICS TEST CIRCUIT

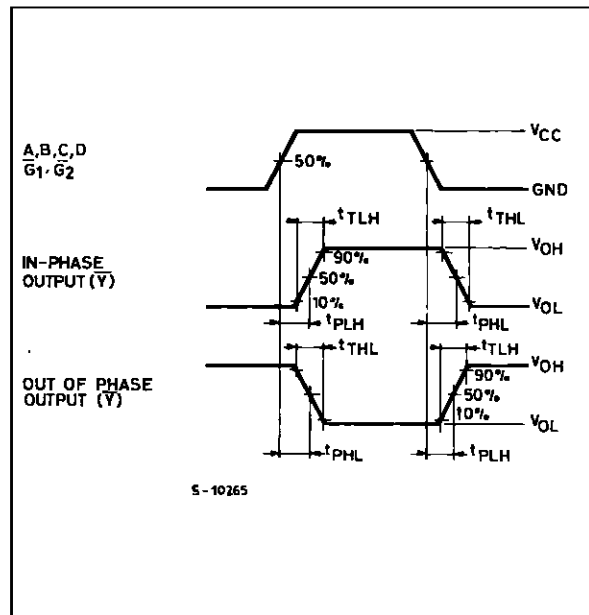

TEST CIRCUIT I_{CC} (Opr.)

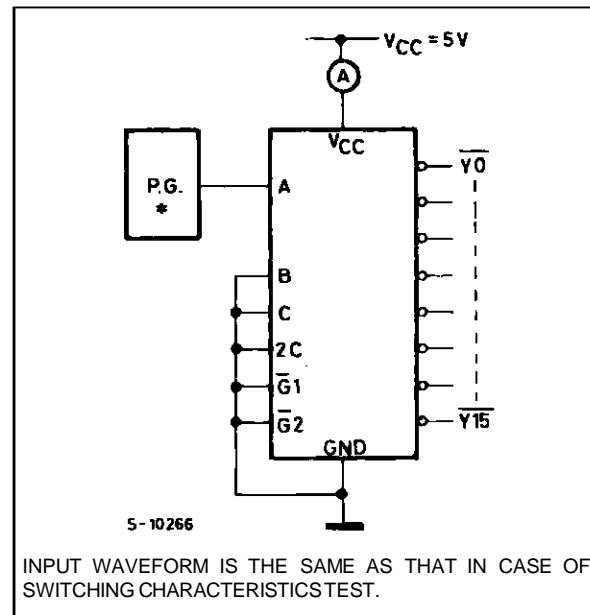

INPUT WAVEFORM IS THE SAME AS THAT IN CASE OF SWITCHING CHARACTERISTICS TEST.

Plastic DIP24 (0.25) MECHANICAL DATA

DIM.	mm			inch		
	MIN.	TYP.	MAX.	MIN.	TYP.	MAX.
a1		0.63			0.025	
b		0.45			0.018	
b1	0.23		0.31	0.009		0.012
b2		1.27			0.050	
D			32.2			1.268
E	15.2		16.68	0.598		0.657
e		2.54			0.100	
e3		27.94			1.100	
F			14.1			0.555
l		4.445			0.175	
L		3.3			0.130	

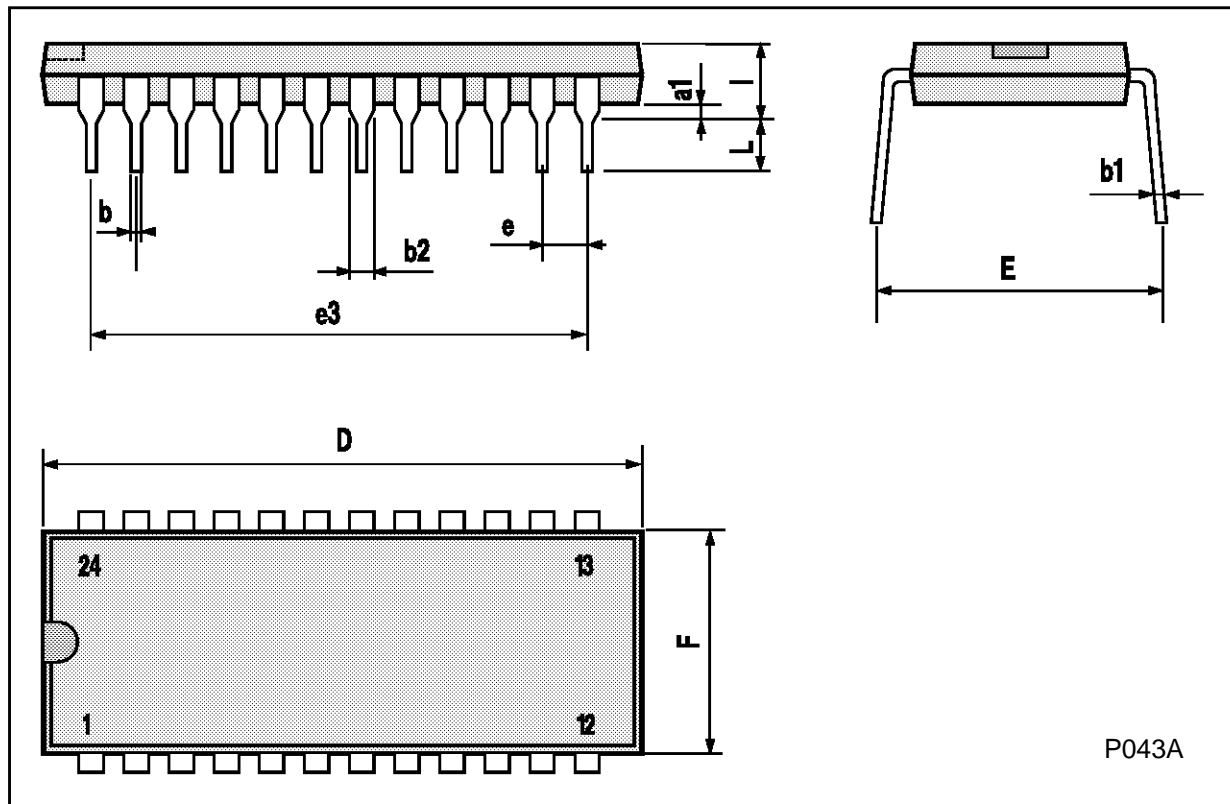

SO24 MECHANICAL DATA

DIM.	mm			inch		
	MIN.	TYP.	MAX.	MIN.	TYP.	MAX.
A			2.65			0.104
a1	0.10		0.20	0.004		0.007
a2			2.45			0.096
b	0.35		0.49	0.013		0.019
b1	0.23		0.32	0.009		0.012
C		0.50			0.020	
c1	45° (typ.)					
D	15.20		15.60	0.598		0.614
E	10.00		10.65	0.393		0.420
e		1.27			0.05	
e3		13.97			0.55	
F	7.40		7.60	0.291		0.299
L	0.50		1.27	0.19		0.050
S	8° (max.)					

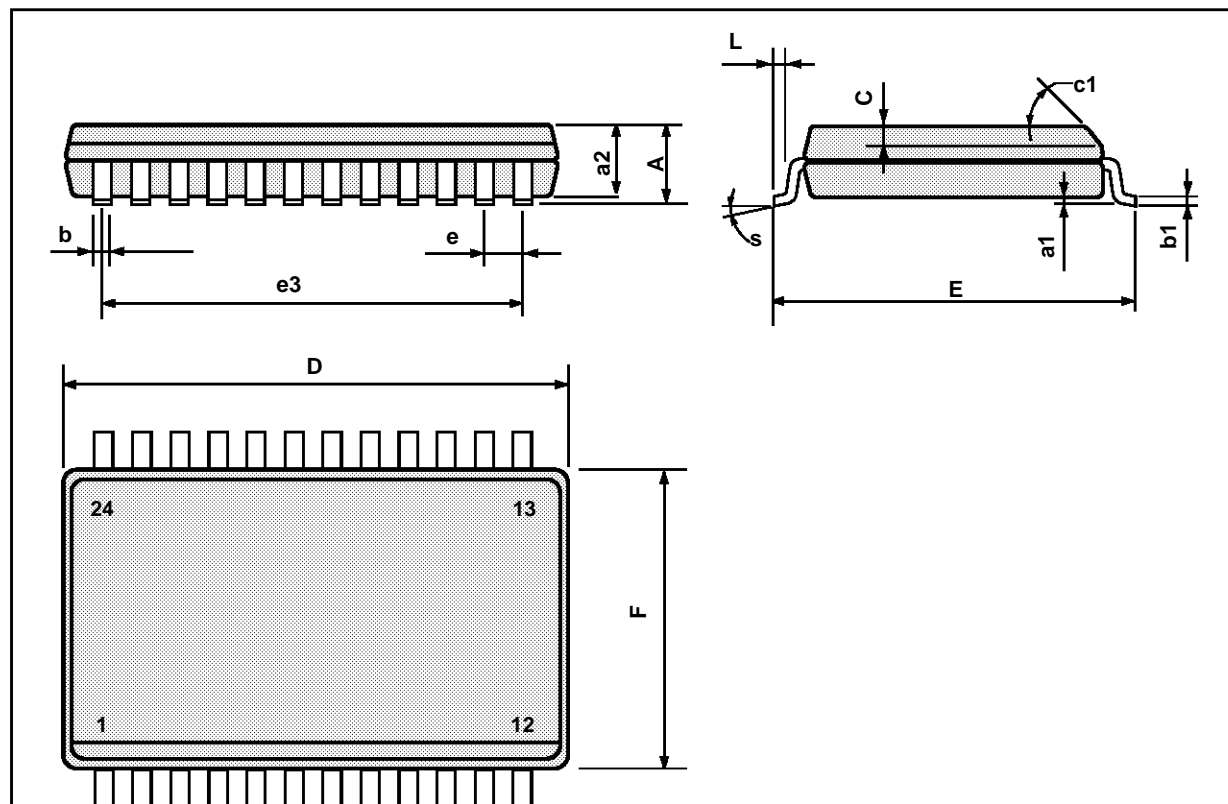

Information furnished is believed to be accurate and reliable. However, SGS-THOMSON Microelectronics assumes no responsibility for the consequences of use of such information nor for any infringement of patents or other rights of third parties which may result from its use. No license is granted by implication or otherwise under any patent or patent rights of SGS-THOMSON Microelectronics. Specifications mentioned in this publication are subject to change without notice. This publication supersedes and replaces all information previously supplied. SGS-THOMSON Microelectronics products are not authorized for use as critical components in life support devices or systems without express written approval of SGS-THOMSON Microelectronics.

© 1994 SGS-THOMSON Microelectronics - All Rights Reserved

SGS-THOMSON Microelectronics GROUP OF COMPANIES

Australia - Brazil - France - Germany - Hong Kong - Italy - Japan - Korea - Malaysia - Malta - Morocco - The Netherlands -
Singapore - Spain - Sweden - Switzerland - Taiwan - Thailand - United Kingdom - U.S.A