

DUAL DECADE COUNTER

- HIGH SPEED
f_{MAX} = 84 MHz (TYP.) AT V_{CC} = 5 V
- LOW POWER DISSIPATION
I_{CC} = 4 μA (MAX.) AT T_A = 25 °C
- HIGH NOISE IMMUNITY
V_{NIH} = V_{NIL} = 28 % V_{CC} (MIN.)
- OUTPUT DRIVE CAPABILITY
10 LSTTL LOADS
- SYMMETRICAL OUTPUT IMPEDANCE
|I_{OH}| = I_{OL} = 4 mA (MIN.)
- BALANCED PROPAGATION DELAYS
t_{PLH} = t_{PHL}
- WIDE OPERATING VOLTAGE RANGE
V_{CC} (OPR) = 2 V TO 6 V
- PIN AND FUNCTION COMPATIBLE WITH
54/74LS390

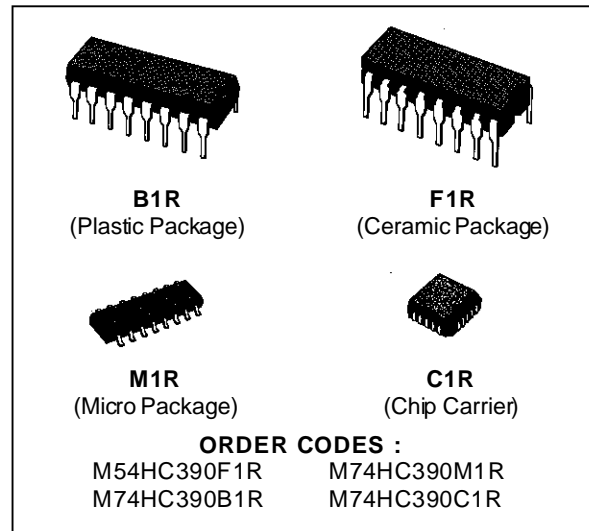

DESCRIPTION

The M54/74HC390 is a high speed CMOS DUAL DECADE COUNTER fabricated in silicon gate C²MOS technology. It has the same high speed performance of LSTTL combined with true CMOS low power consumption.

This dual decade counter contains two independent ripple carry counters. Each counter is composed of a divide-by-two and divide-by-five counter. The divide-by-two and divide-by-five counters can be cascaded to form dual decade, dual biquinary, or various combinations up to a single divide-by-100 counter.

Each 4-bit counter is incremented on the high to low transition (negative edge) of the clock input, and each has an independent clear input. When clear is set low all four bits of each counter are set to low. This enables count truncation and allows the implementation of divide-by-N counter configurations.

All inputs are equipped with protection circuits against static discharge and transient excess voltage.

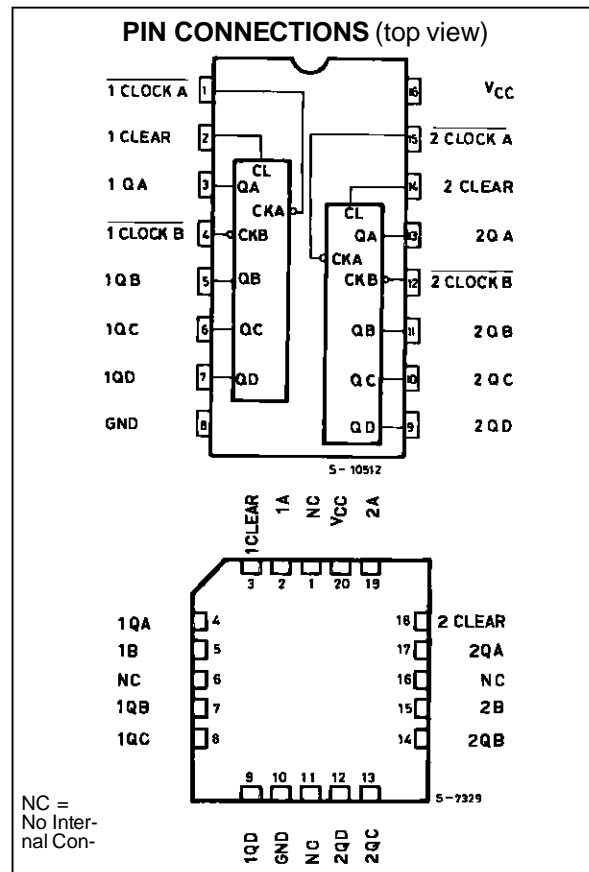

INPUT AND OUTPUT EQUIVALENT CIRCUIT



TRUTH TABLE

COUNT	OUTPUTS							
	BCD COUNT *				BI-QUINARY **			
	QD	QC	QB	QA	QA	QD	QC	QB
0	L	L	L	L	L	L	L	L
1	L	L	L	H	L	L	L	H
2	L	L	H	L	L	L	H	L
3	L	L	H	H	L	L	H	H
4	L	H	L	L	L	H	L	L
5	L	H	L	H	H	L	L	L
6	L	H	H	L	H	L	L	H
7	L	H	H	H	H	L	H	L
8	H	L	L	L	H	L	H	H
9	H	L	L	H	H	H	L	L

INPUTS			OUTPUTS			
CLOCK A	CLOCK B	CLEAR	QA	QB	QC	QD
X	X	H	L	L	L	L
$\overline{\text{L}}$	X	L	BINARY COUNT UP			
X	$\overline{\text{L}}$	L	QUINARY COUNT UP			

Note: * Output QA is connected to input $\overline{\text{CLOCK B}}$ for BCD count.

** Output QD is connected to input $\overline{\text{CLOCK A}}$ for bi-quinary count.

BLOCK DIAGRAM

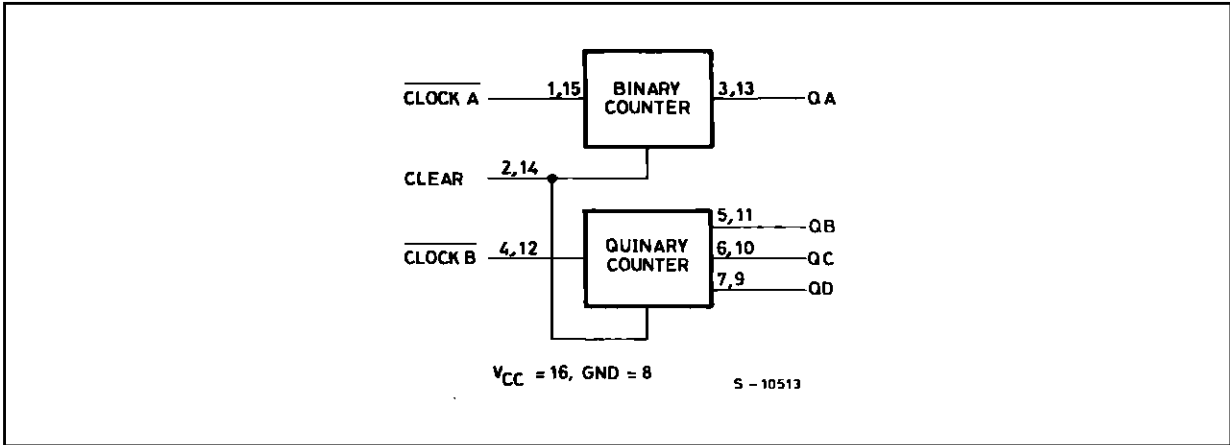

LOGIC DIAGRAM

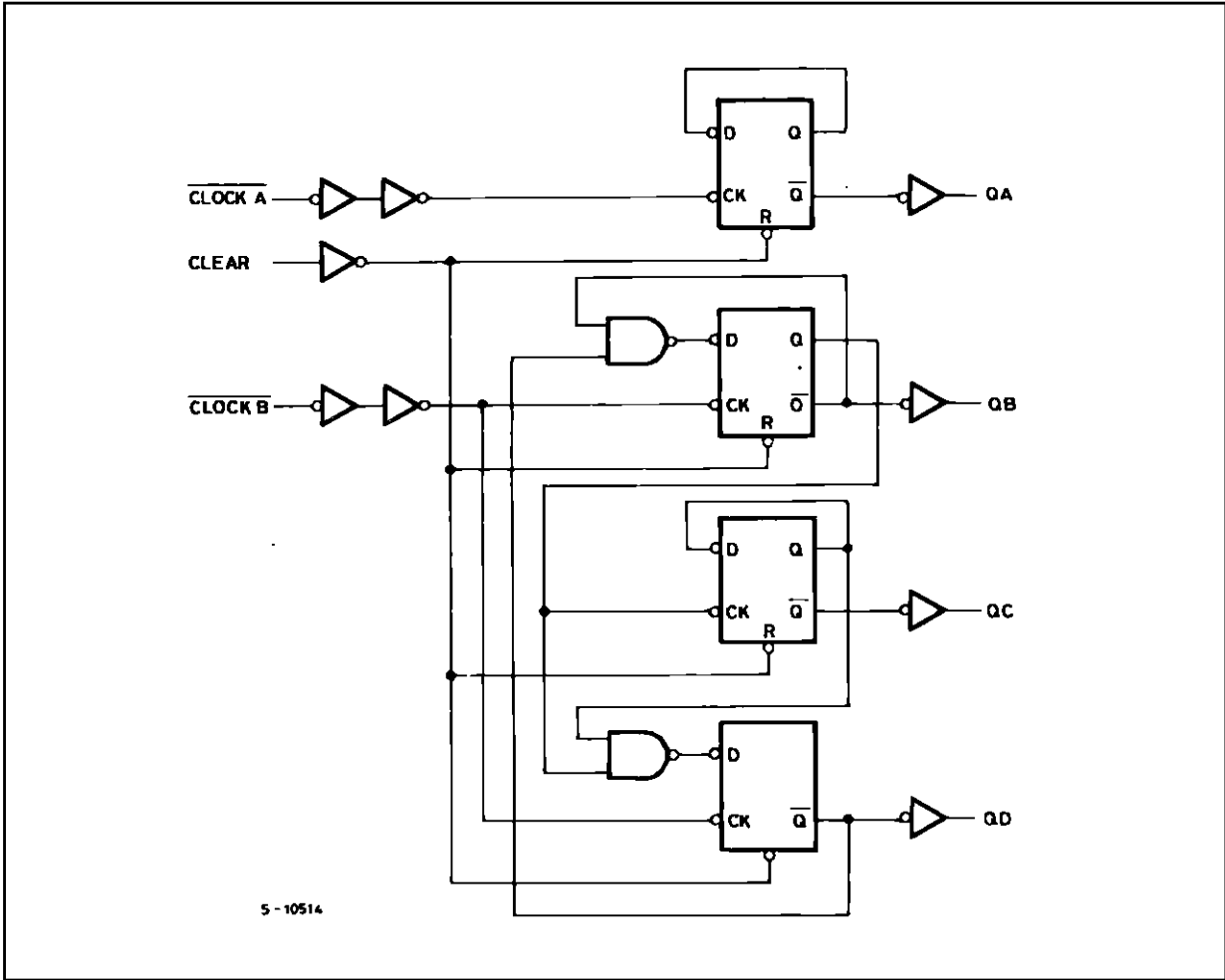

TIMING CHART

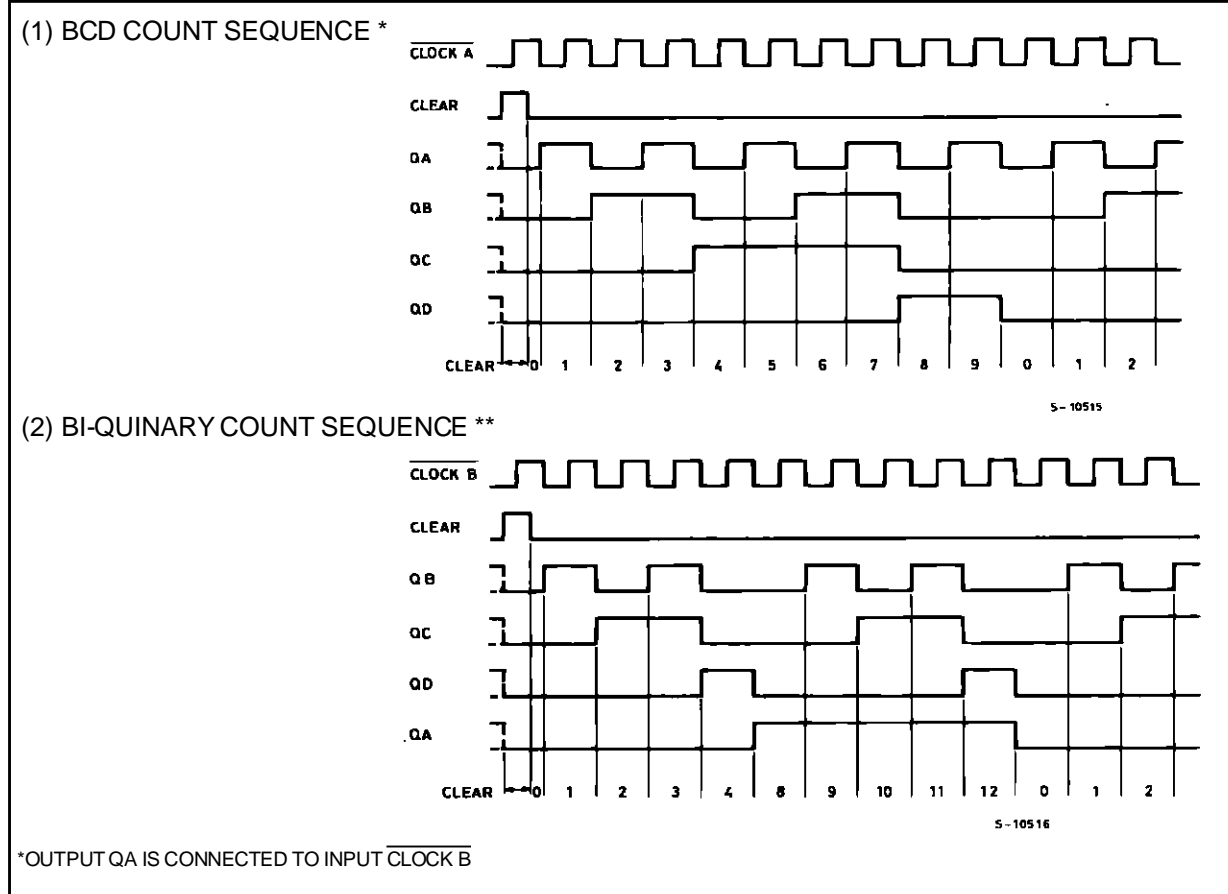

PIN DESCRIPTION

PIN No	SYMBOL	NAME AND FUNCTION
1, 15	1 CLOCK A 2 CLOCK B	Clock Input Divide by 2 Section (HIGH to LOW Edge-triggered)
2, 14	1 CLEAR 2 CLEAR	Asynchronous Master Reset Inputs
3, 5, 6, 7	1QA to 1QD	Flip Flop Outputs
4, 12	1 CLOCK B 2 CLOCK B	Clock Input Divide by 5 Section (HIGH to LOW Edge-triggered)
13, 11, 10, 9	2QA to 2QD	Flip Flop Outputs
8	GND	Ground (0V)
16	V _{CC}	Positive Supply Voltage

IEC LOGIC SYMBOL

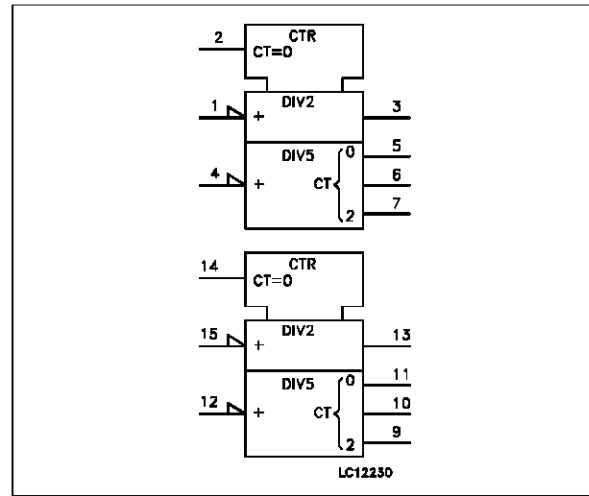

ABSOLUTE MAXIMUM RATINGS

Symbol	Parameter	Value	Unit
V _{CC}	Supply Voltage	-0.5 to +7	V
V _I	DC Input Voltage	-0.5 to V _{CC} + 0.5	V
V _O	DC Output Voltage	-0.5 to V _{CC} + 0.5	V
I _{IK}	DC Input Diode Current	± 20	mA
I _{OK}	DC Output Diode Current	± 20	mA
I _O	DC Output Source Sink Current Per Output Pin	± 25	mA
I _{CC} or I _{GND}	DC V _{CC} or Ground Current	± 50	mA
P _D	Power Dissipation	500 (*)	mW
T _{stg}	Storage Temperature	-65 to +150	°C
T _L	Lead Temperature (10 sec)	300	°C

Absolute Maximum Ratings are those values beyond which damage to the device may occur. Functional operation under these condition is not implied.
 (*) 500 mW: ± 65 °C derate to 300 mW by 10mW/°C: 65 °C to 85 °C

RECOMMENDED OPERATING CONDITIONS

Symbol	Parameter	Value	Unit	
V _{CC}	Supply Voltage	2 to 6	V	
V _I	Input Voltage	0 to V _{CC}	V	
V _O	Output Voltage	0 to V _{CC}	V	
T _{op}	Operating Temperature: M54HC Series M74HC Series	-55 to +125 -40 to +85	°C °C	
t _r , t _f	Input Rise and Fall Time	V _{CC} = 2 V V _{CC} = 4.5 V V _{CC} = 6 V	0 to 1000 0 to 500 0 to 400	ns

DC SPECIFICATIONS

Symbol	Parameter	Test Conditions		Value						Unit		
		V _{CC} (V)		T _A = 25 °C 54HC and 74HC			-40 to 85 °C 74HC		-55 to 125 °C 54HC			
				Min.	Typ.	Max.	Min.	Max.	Min.		Max.	
V _{IH}	High Level Input Voltage	2.0		1.5			1.5		1.5		V	
		4.5		3.15			3.15		3.15			
		6.0		4.2			4.2		4.2			
V _{IL}	Low Level Input Voltage	2.0				0.5		0.5		0.5	V	
		4.5				1.35		1.35		1.35		
		6.0				1.8		1.8		1.8		
V _{OH}	High Level Output Voltage	2.0	V _I = V _{IH} or V _{IL}	I _O = -20 μA	1.9	2.0		1.9		1.9	V	
		4.5			4.4	4.5		4.4		4.4		
		6.0			5.9	6.0		5.9		5.9		
		4.5	I _O = -4.0 mA	4.18	4.31		4.13		4.10			
		6.0		I _O = -5.2 mA	5.68	5.8		5.63		5.60		
V _{OL}	Low Level Output Voltage	2.0	V _I = V _{IH} or V _{IL}	I _O = 20 μA		0.0	0.1		0.1		0.1	V
		4.5				0.0	0.1		0.1		0.1	
		6.0				0.0	0.1		0.1		0.1	
		4.5		I _O = 4.0 mA		0.17	0.26		0.33		0.40	
		6.0			I _O = 5.2 mA		0.18	0.26		0.33		
I _I	Input Leakage Current	6.0	V _I = V _{CC} or GND			±0.1		±1		±1	μA	
I _{CC}	Quiescent Supply Current	6.0	V _I = V _{CC} or GND			4		40		80	μA	

AC ELECTRICAL CHARACTERISTICS ($C_L = 50 \text{ pF}$, Input $t_r = t_f = 6 \text{ ns}$)

Symbol	Parameter	Test Conditions		Value						Unit	
		V_{CC} (V)		$T_A = 25 \text{ }^\circ\text{C}$ 54HC and 74HC			$-40 \text{ to } 85 \text{ }^\circ\text{C}$ 74HC		$-55 \text{ to } 125 \text{ }^\circ\text{C}$ 54HC		
				Min.	Typ.	Max.	Min.	Max.	Min.		Max.
t_{TLH} t_{THL}	Output Transition Time	2.0			30	75		95		110	ns
		4.5			8	15		19		22	
		6.0			7	13		16		19	
t_{PLH} t_{PHL}	Propagation Delay Time (CLOCK A - QA)	2.0			42	120		150		180	ns
		4.5			14	24		30		36	
		6.0			12	20		26		31	
t_{PLH} t_{PHL}	Propagation Delay Time (CLOCK A - QB, QD)	2.0			45	120		150		180	ns
		4.5			15	24		30		36	
		6.0			13	20		26		31	
t_{PLH} t_{PHL}	Propagation Delay Time (CLOCK A - QC)	2.0	QA Connected to CKB		108	280		350		420	ns
		4.5			36	56		70		84	
		6.0			31	48		60		71	
t_{PLH} t_{PHL}	Propagation Delay Time (CLOCK B - QC)	2.0			72	185		230		280	ns
		4.5			24	37		46		56	
		6.0			20	31		39		48	
t_{PHL}	Propagation Delay Time (CLEAR - Qn)	2.0			45	125		155		190	ns
		4.5			15	25		31		38	
		6.0			13	21		26		32	
f_{MAX}	Maximum Clock Frequency (CLOCK A - QA)	2.0			8.4	17		6.8		5.6	ns
		4.5			42	65		34		28	
		6.0			50	79		40		33	
f_{MAX}	Maximum Clock Frequency (CLOCK B - QB)	2.0			8.4	17		6.8		5.6	ns
		4.5			42	67		34		28	
		6.0			50	79		40		33	
$t_{W(H)}$ $t_{W(L)}$	Minimum Pulse Width (CLOCK)	2.0			24	75		95		110	ns
		4.5			6	15		19		22	
		6.0			5	13		16		19	
$t_{(W)H}$	Minimum Pulse Width (CLEAR)	2.0			24	75		95		110	ns
		4.5			6	15		19		22	
		6.0			5	13		16		19	
t_{REM}	Propagation Delay Time	2.0				25		30		35	ns
		4.5				5		6		7	
		6.0					5		5		
C_{IN}	Input Capacitance				5	10		10		10	pF
C_{PD} (*)	Power Dissipation Capacitance				84						pF

(*) C_{PD} is defined as the value of the IC's internal equivalent capacitance which is calculated from the operating current consumption without load. (Refer to Test Circuit). Average operating current can be obtained by the following equation. $I_{CC(opr)} = C_{PD} \cdot V_{CC} \cdot f_{IN} + I_{CC}$

TEST CIRCUIT I_{CC} (Opr.)

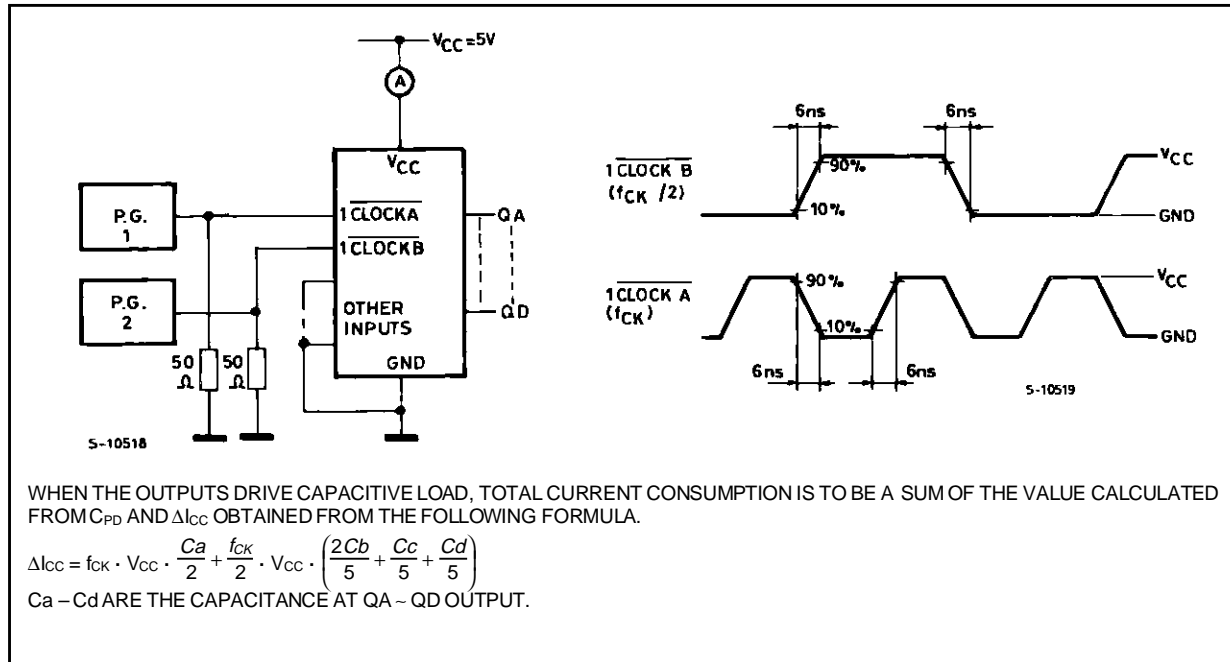

SWITCHING CHARACTERISTICS TEST WAVEFORM

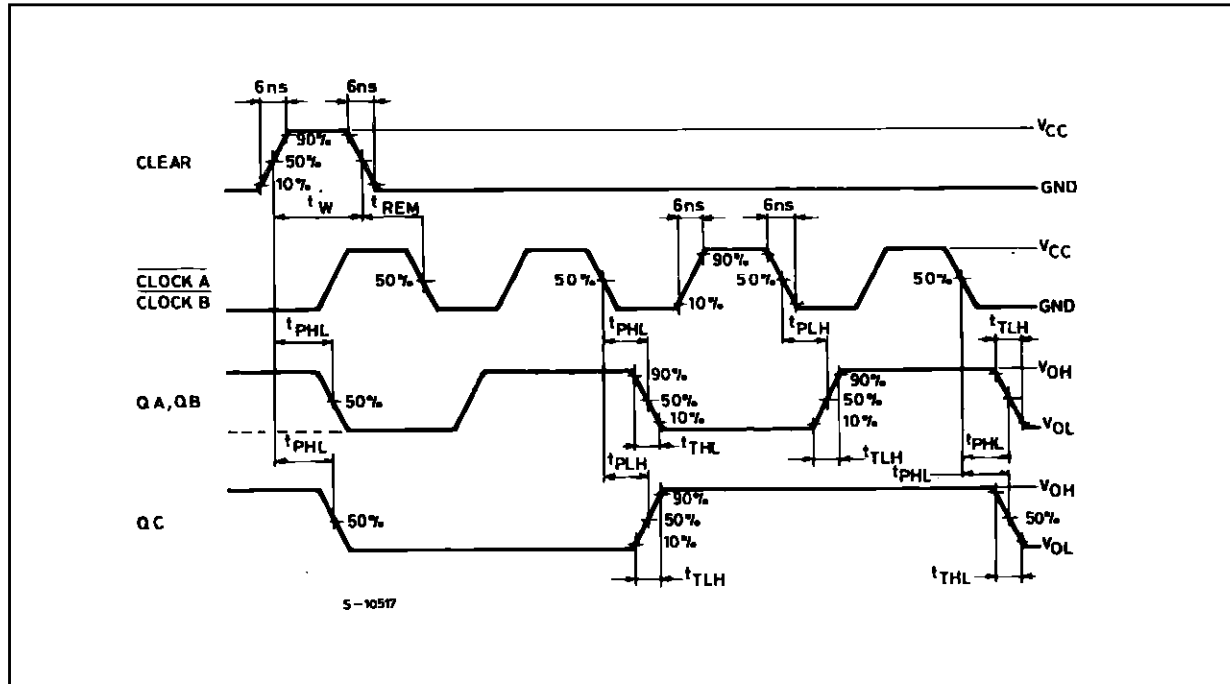

Plastic DIP16 (0.25) MECHANICAL DATA

DIM.	mm			inch		
	MIN.	TYP.	MAX.	MIN.	TYP.	MAX.
a1	0.51			0.020		
B	0.77		1.65	0.030		0.065
b		0.5			0.020	
b1		0.25			0.010	
D			20			0.787
E		8.5			0.335	
e		2.54			0.100	
e3		17.78			0.700	
F			7.1			0.280
I			5.1			0.201
L		3.3			0.130	
Z			1.27			0.050

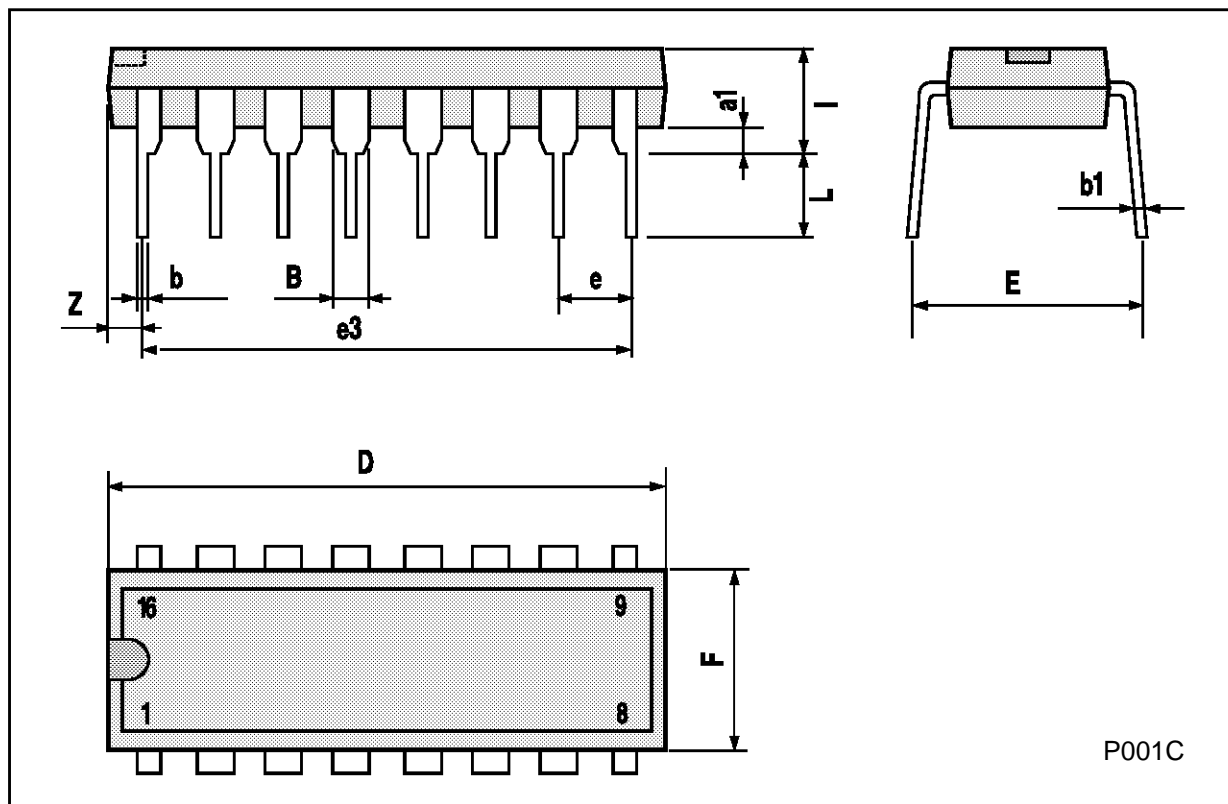

Ceramic DIP16/1 MECHANICAL DATA

DIM.	mm			inch		
	MIN.	TYP.	MAX.	MIN.	TYP.	MAX.
A			20			0.787
B			7			0.276
D		3.3			0.130	
E	0.38			0.015		
e3		17.78			0.700	
F	2.29		2.79	0.090		0.110
G	0.4		0.55	0.016		0.022
H	1.17		1.52	0.046		0.060
L	0.22		0.31	0.009		0.012
M	0.51		1.27	0.020		0.050
N			10.3			0.406
P	7.8		8.05	0.307		0.317
Q			5.08			0.200



SO16 (Narrow) MECHANICAL DATA

DIM.	mm			inch		
	MIN.	TYP.	MAX.	MIN.	TYP.	MAX.
A			1.75			0.068
a1	0.1		0.2	0.004		0.007
a2			1.65			0.064
b	0.35		0.46	0.013		0.018
b1	0.19		0.25	0.007		0.010
C		0.5			0.019	
c1	45° (typ.)					
D	9.8		10	0.385		0.393
E	5.8		6.2	0.228		0.244
e		1.27			0.050	
e3		8.89			0.350	
F	3.8		4.0	0.149		0.157
G	4.6		5.3	0.181		0.208
L	0.5		1.27	0.019		0.050
M			0.62			0.024
S	8° (max.)					

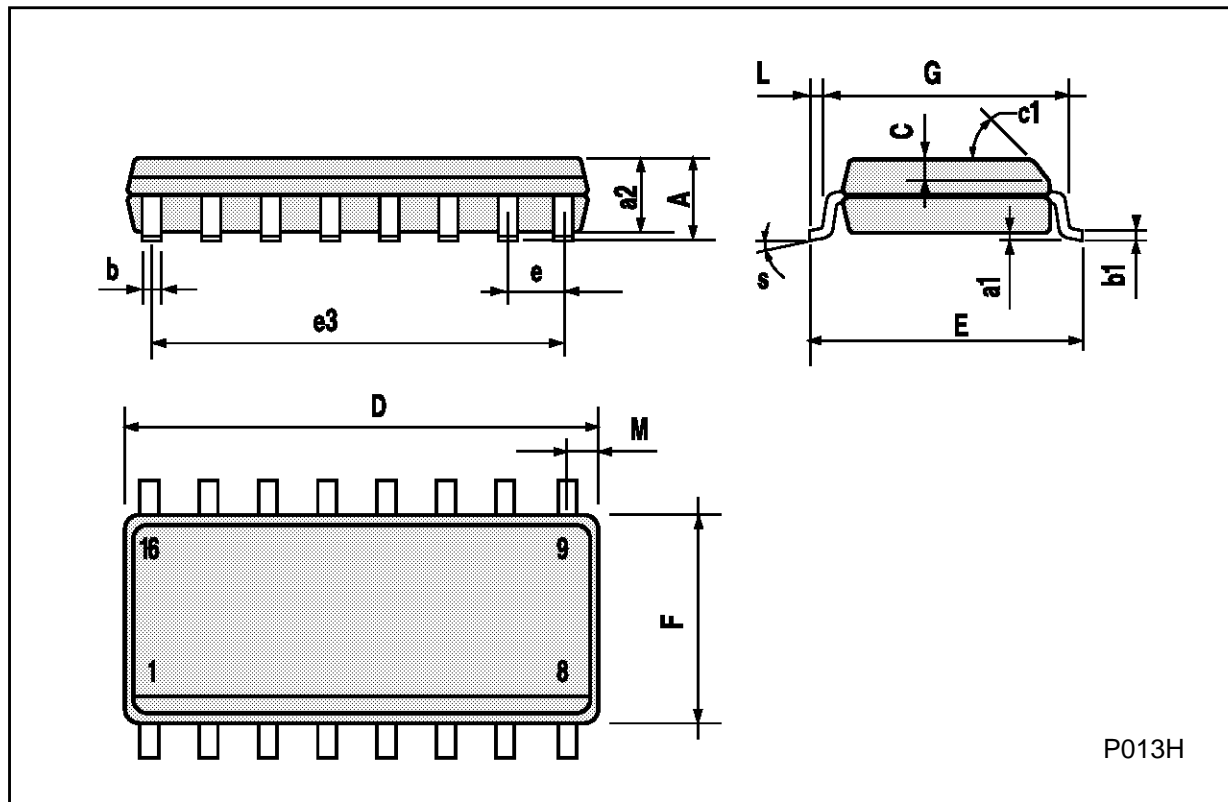

P013H

PLCC20 MECHANICAL DATA

DIM.	mm			inch		
	MIN.	TYP.	MAX.	MIN.	TYP.	MAX.
A	9.78		10.03	0.385		0.395
B	8.89		9.04	0.350		0.356
D	4.2		4.57	0.165		0.180
d1		2.54			0.100	
d2		0.56			0.022	
E	7.37		8.38	0.290		0.330
e		1.27			0.050	
e3		5.08			0.200	
F		0.38			0.015	
G			0.101			0.004
M		1.27			0.050	
M1		1.14			0.045	



Information furnished is believed to be accurate and reliable. However, SGS-THOMSON Microelectronics assumes no responsibility for the consequences of use of such information nor for any infringement of patents or other rights of third parties which may result from its use. No license is granted by implication or otherwise under any patent or patent rights of SGS-THOMSON Microelectronics. Specifications mentioned in this publication are subject to change without notice. This publication supersedes and replaces all information previously supplied. SGS-THOMSON Microelectronics products are not authorized for use as critical components in life support devices or systems without express written approval of SGS-THOMSON Microelectronics.

© 1994 SGS-THOMSON Microelectronics - All Rights Reserved

SGS-THOMSON Microelectronics GROUP OF COMPANIES

Australia - Brazil - France - Germany - Hong Kong - Italy - Japan - Korea - Malaysia - Malta - Morocco - The Netherlands -
Singapore - Spain - Sweden - Switzerland - Taiwan - Thailand - United Kingdom - U.S.A