

## HC4514: 4 TO 16 LINE DECODER/LATCH HC4515: 4 TO 16 LINE DECODER LATCH (INV.)

- HIGH SPEED  
 $t_{PD} = 18 \text{ ns (TYP.) AT } V_{CC} = 5 \text{ V}$
- LOW POWER DISSIPATION  
 $I_{CC} = 4 \mu\text{A (MAX.) AT } T_A = 25 \text{ }^\circ\text{C}$
- HIGH NOISE IMMUNITY  
 $V_{NIH} = V_{NIL} = 28 \% V_{CC} \text{ (MIN.)}$
- OUTPUT DRIVE CAPABILITY  
 10 LSTTL LOADS
- SYMMETRICAL OUTPUT IMPEDANCE  
 $|I_{OH}| = I_{OL} = 4 \text{ mA (MIN.)}$
- BALANCED PROPAGATION DELAYS  
 $t_{PLH} = t_{PHL}$
- WIDE OPERATING VOLTAGE RANGE  
 $V_{CC(OPR)} = 2 \text{ V TO } 6 \text{ V}$
- PIN AND FUNCTION COMPATIBLE WITH  
 4514B/4515B

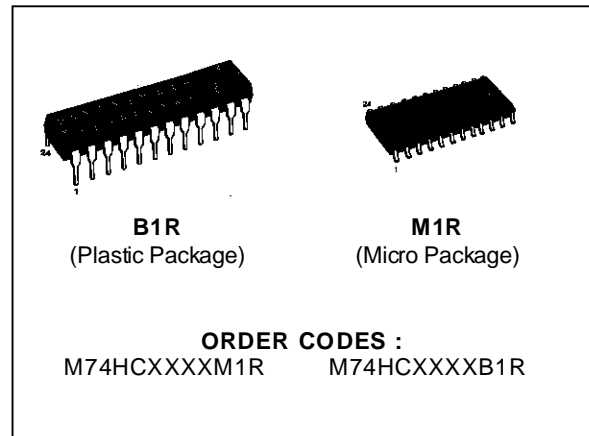

### DESCRIPTION

The 74HC4514 and the 74HC4515 are high speed CMOS 4-LINE TO 16-LINE DECODERS WITH LATCHED INPUTS fabricated in silicon gate C<sup>2</sup>MOS technology. They have the same high speed performance of LSTTL combined with true CMOS low power consumption.

A binary code stored in the four input latches (A to D) provides a high level (HC4514) or a low level (HC4515) at the selected one of sixteen outputs excluding the other fifteen outputs, when the inhibit input (INHIBIT) is held low. When the inhibit input is held high, all outputs are kept low level (HC4514) or high level (HC4515), while the latch function is available. The data applied to the data inputs are transferred to the Q outputs of latches when the strobe input is held high. When the strobe input is taken low, the information data applied to the data input at a time is retained at the output of the latches. All inputs are equipped with protection circuits against static discharge and transient excess voltage.

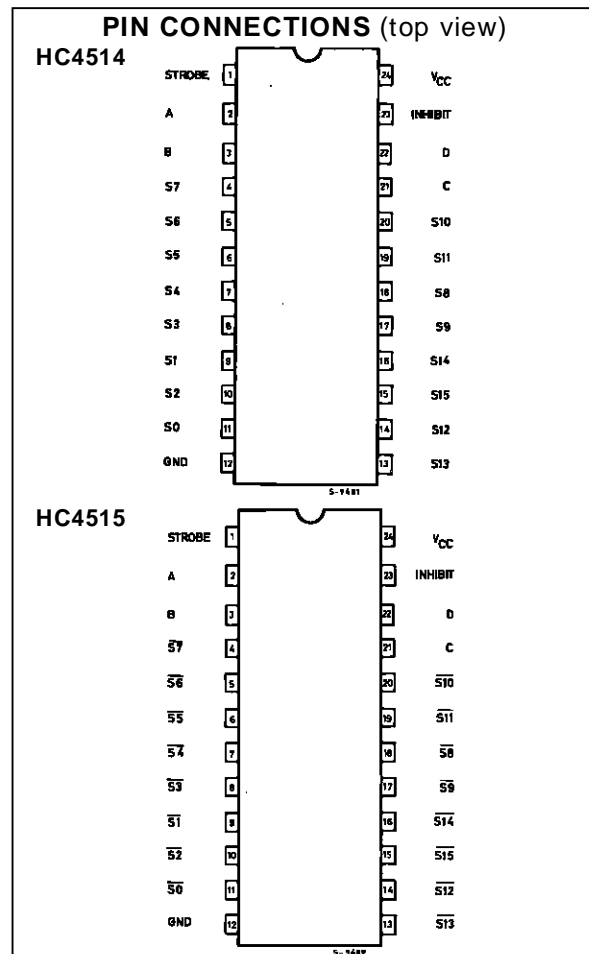

# M74HC4514/4515

## TRUTH TABLE

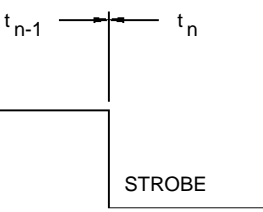
INPUTS					STROBE	SELECT OUTPUT HC4514 - 'H' (HC4515 - 'L')
INHIBIT	A	B	C	D		
L	L	L	L	L	STROBE = 'H' Refer to truth table  STROBE = 'L' Data at the negative going transition of strobe shall be provided on the each output while strobe is held low.  	S0 ( $\overline{S0}$ )
L	H	L	L	L		S1 ( $\overline{S1}$ )
L	L	H	L	L		S2 ( $\overline{S2}$ )
L	H	H	L	L		S3 ( $\overline{S3}$ )
L	L	L	H	L		S4 ( $\overline{S4}$ )
L	H	L	H	L		S5 ( $\overline{S5}$ )
L	L	H	H	L		S6 ( $\overline{S6}$ )
L	H	H	H	L		S7 ( $\overline{S7}$ )
L	L	L	L	H		S8 ( $\overline{S8}$ )
L	H	L	L	H		S9 ( $\overline{S9}$ )
L	L	H	L	H		S10 ( $\overline{S10}$ )
L	H	H	L	H		S11 ( $\overline{S11}$ )
L	L	L	H	H		S12 ( $\overline{S12}$ )
L	H	L	H	H		S13 ( $\overline{S13}$ )
L	L	H	H	H		S14 ( $\overline{S14}$ )
L	H	H	H	H		S15 ( $\overline{S15}$ )
H	X	X	X	X	HC4514 - ALL OUTPUTS 'L' (HC4515 - ALL OUTPUTS 'H')	

## LOGIC DIAGRAM (HC4514)

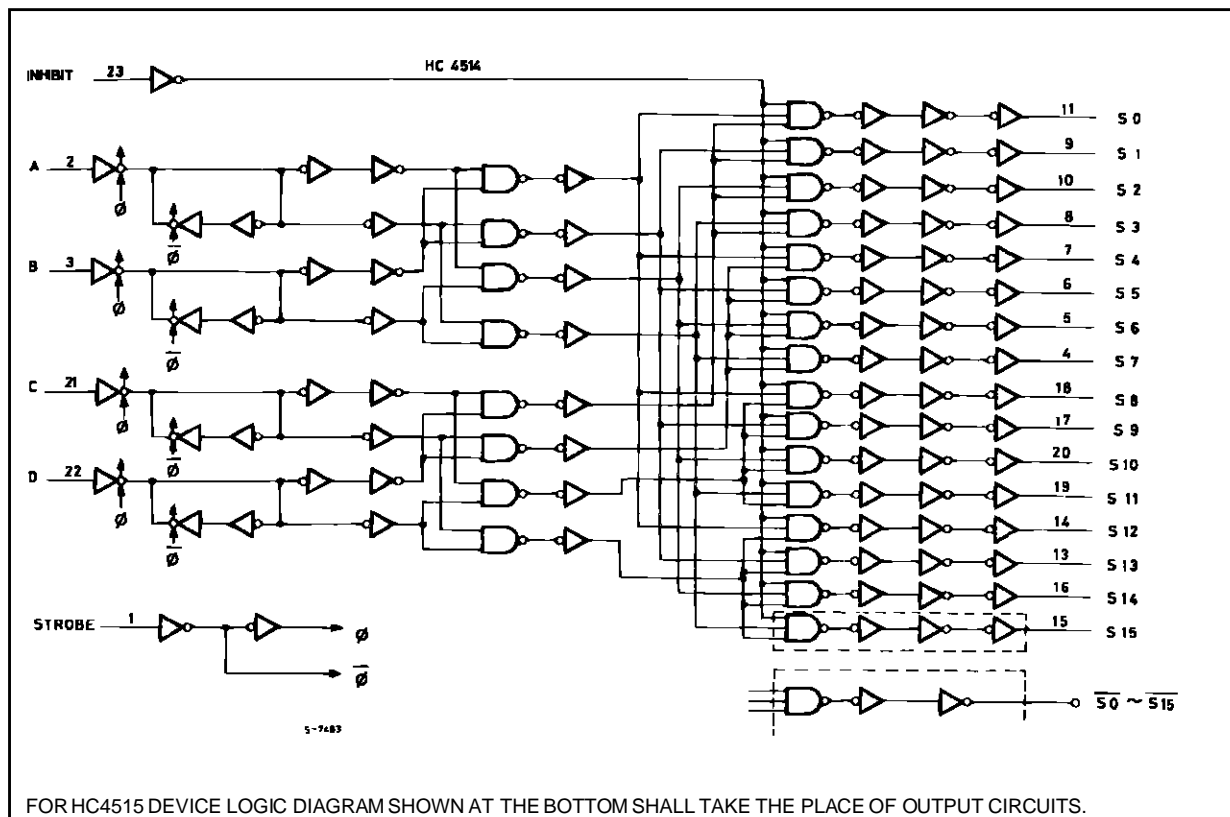

**PIN DESCRIPTION (HC4514)**

PIN No	SYMBOL	NAME AND FUNCTION
1	STROBE	Strobe Input
2, 3, 21, 22	A to D	Address Inputs
11, 9, 10, 8, 7, 6, 5, 4, 18, 17, 20, 19, 14, 13, 16, 15	S0 to S15	Multiplexer Outputs (Active HIGH)
23	INHIBIT	Enable Input
12	GND	Ground (0V)
24	V <sub>CC</sub>	Positive Supply Voltage

**PIN DESCRIPTION (HC4515)**

PIN No	SYMBOL	NAME AND FUNCTION
1	STROBE	Strobe Input
2, 3, 21, 22	A to D	Address Inputs
11, 9, 10, 8, 7, 6, 5, 4, 18, 17, 20, 19, 14, 13, 16, 15	$\overline{S0}$ to $\overline{S15}$	Multiplexer Outputs (Active LOW)
23	INHIBIT	Enable Input
12	GND	Ground (0V)
24	V <sub>CC</sub>	Positive Supply Voltage

**IEC LOGIC SYMBOLS**

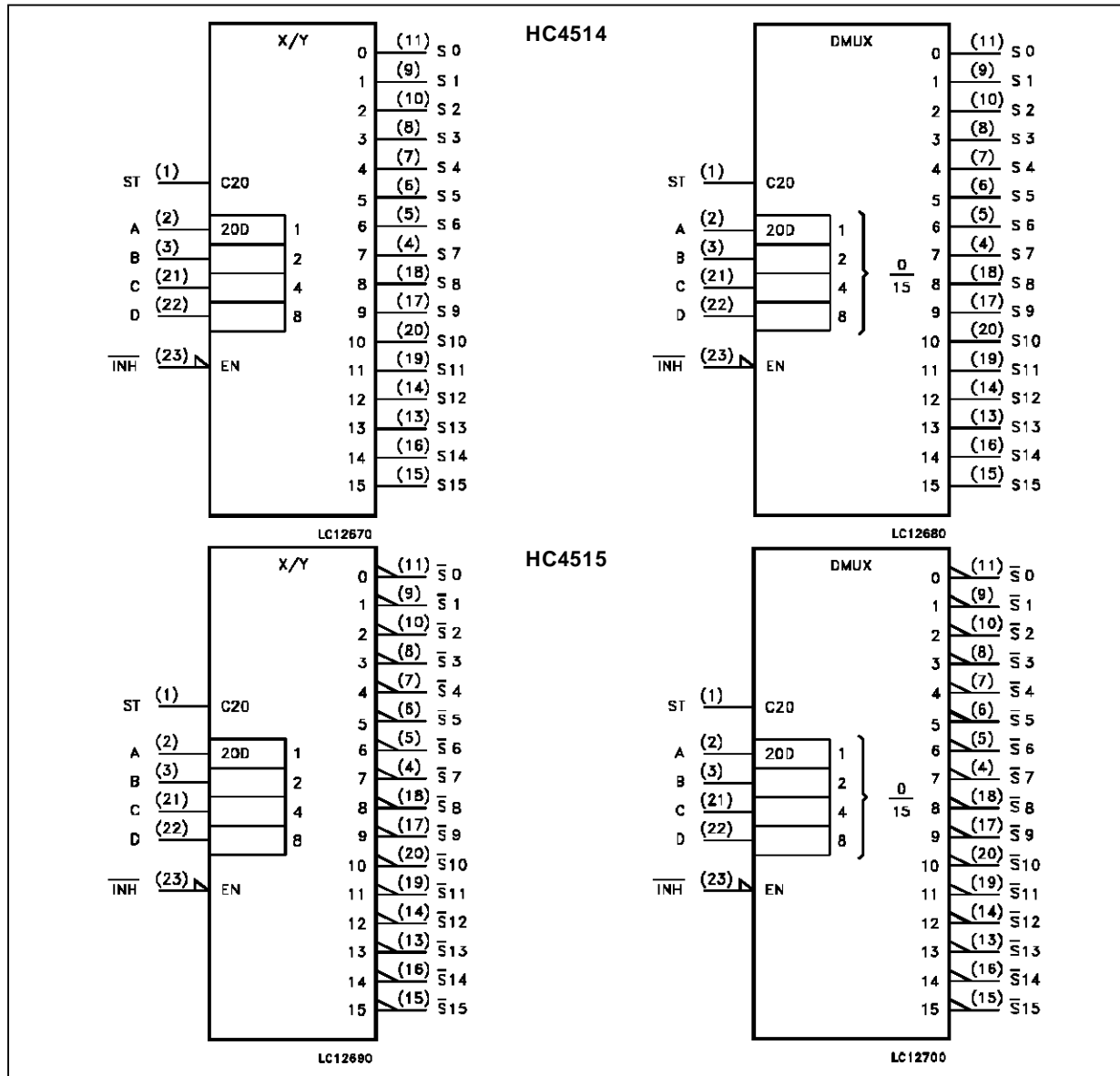

INPUT AND OUTPUT EQUIVALENT CIRCUIT

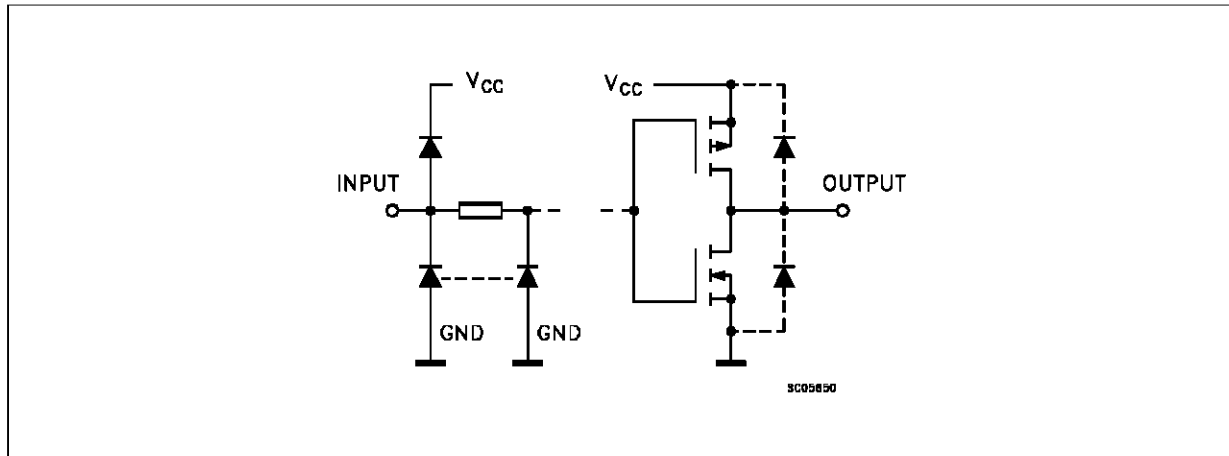

ABSOLUTE MAXIMUM RATINGS

Symbol	Parameter	Value	Unit
$V_{CC}$	Supply Voltage	-0.5 to +7	V
$V_I$	DC Input Voltage	-0.5 to $V_{CC} + 0.5$	V
$V_O$	DC Output Voltage	-0.5 to $V_{CC} + 0.5$	V
$I_{IK}$	DC Input Diode Current	$\pm 20$	mA
$I_{OK}$	DC Output Diode Current	$\pm 20$	mA
$I_O$	DC Output Source Sink Current Per Output Pin	$\pm 25$	mA
$I_{CC}$ or $I_{GND}$	DC $V_{CC}$ or Ground Current	$\pm 50$	mA
$P_D$	Power Dissipation	500 (*)	mW
$T_{stg}$	Storage Temperature	-65 to +150	$^{\circ}C$
$T_L$	Lead Temperature (10 sec)	300	$^{\circ}C$

Absolute Maximum Ratings are those values beyond which damage to the device may occur. Functional operation under these condition is not implied.

(\*) 500 mW:  $\equiv 65^{\circ}C$  derate to 300 mW by 10mW/ $^{\circ}C$ : 65  $^{\circ}C$  to 85  $^{\circ}C$

RECOMMENDED OPERATING CONDITIONS

Symbol	Parameter	Value	Unit	
$V_{CC}$	Supply Voltage	2 to 6	V	
$V_I$	Input Voltage	0 to $V_{CC}$	V	
$V_O$	Output Voltage	0 to $V_{CC}$	V	
$T_{op}$	Operating Temperature	-40 to +85	$^{\circ}C$	
$t_r, t_f$	Input Rise and Fall Time	$V_{CC} = 2 V$	0 to 1000	ns
		$V_{CC} = 4.5 V$	0 to 500	
		$V_{CC} = 6 V$	0 to 400	

## DC SPECIFICATIONS

Symbol	Parameter	Test Conditions		Value					Unit	
		V <sub>CC</sub> (V)		T <sub>A</sub> = 25 °C			-40 to 85 °C			
				Min.	Typ.	Max.	Min.	Max.		
V <sub>IH</sub>	High Level Input Voltage	2.0		1.5			1.5		V	
		4.5		3.15			3.15			
		6.0		4.2			4.2			
V <sub>IL</sub>	Low Level Input Voltage	2.0				0.5		0.5	V	
		4.5				1.35		1.35		
		6.0				1.8		1.8		
V <sub>OH</sub>	High Level Output Voltage	2.0	V <sub>I</sub> = V <sub>IH</sub> or V <sub>IL</sub>	I <sub>O</sub> = -20 μA	1.9	2.0		1.9		V
		4.5			4.4	4.5		4.4		
		6.0			5.9	6.0		5.9		
		4.5	I <sub>O</sub> = -4.0 mA	4.18	4.31		4.13			
		6.0		I <sub>O</sub> = -5.2 mA	5.68	5.8		5.63		
V <sub>OL</sub>	Low Level Output Voltage	2.0	V <sub>I</sub> = V <sub>IH</sub> or V <sub>IL</sub>	I <sub>O</sub> = 20 μA		0.0	0.1		0.1	V
		4.5				0.0	0.1		0.1	
		6.0				0.0	0.1		0.1	
		4.5	I <sub>O</sub> = 4.0 mA		0.17	0.26		0.33		
		6.0		I <sub>O</sub> = 5.2 mA		0.18	0.26		0.33	
I <sub>I</sub>	Input Leakage Current	6.0	V <sub>I</sub> = V <sub>CC</sub> or GND				±0.1		±1	μA
I <sub>OZ</sub>	3 State Output Off State Current	6.0	V <sub>I</sub> = V <sub>IH</sub> or V <sub>IL</sub> V <sub>O</sub> = V <sub>CC</sub> or GND				±0.5		±5.0	μA
I <sub>CC</sub>	Quiescent Supply Current	6.0	V <sub>I</sub> = V <sub>CC</sub> or GND				4		40	μA

## M74HC4514/4515

### AC ELECTRICAL CHARACTERISTICS ( $C_L = 50$ pF, Input $t_r = t_f = 6$ ns)

Symbol	Parameter	Test Conditions		Value					Unit
		V <sub>CC</sub> (V)		T <sub>A</sub> = 25 °C			-40 to 85 °C		
				Min.	Typ.	Max.	Min.	Max.	
t <sub>TLH</sub> t <sub>THL</sub>	Output Transition Time	2.0			30	75		95	ns
		4.5			8	15		19	
		6.0			7	13		16	
t <sub>PLH</sub> t <sub>PHL</sub>	Propagation Delay Time (DATA - Sn, Sn)	2.0			65	175		220	ns
		4.5			22	35		44	
		6.0			19	30		37	
t <sub>PHL</sub> t <sub>PLH</sub>	Propagation Delay Time (STROBE - Sn, Sn)	2.0			75	175		220	ns
		4.5			24	35		44	
		6.0			20	30		37	
t <sub>PHL</sub> t <sub>PLH</sub>	Propagation Delay Time (INHIBIT - Sn, Sn)	2.0			60	175		220	ns
		4.5			20	35		44	
		6.0			17	30		37	
t <sub>W(L)</sub>	Minimum Pulse Width (STROBE)	2.0			14	75		95	ns
		4.5			6	15		19	
		6.0			6	13		16	
t <sub>s</sub>	Minimum Set-up Time (DATA)	2.0			10	50		65	ns
		4.5			2	10		13	
		6.0			2	9		11	
t <sub>h</sub>	Minimum Hold Time (DATA)	2.0				5		5	ns
		4.5				5		5	
		6.0				5		5	
C <sub>IN</sub>	Input Capacitance				5	10		10	pF
C <sub>PD</sub> (*)	Power Dissipation Capacitance				61				pF

(\*) C<sub>PD</sub> is defined as the value of the IC's internal equivalent capacitance which is calculated from the operating current consumption without load. (Refer to Test Circuit). Average operating current can be obtained by the following equation.  $I_{CC(opr)} = C_{PD} \cdot V_{CC} \cdot f_{IN} + I_{CC}$



**Plastic DIP24 (0.25) MECHANICAL DATA**

DIM.	mm			inch		
	MIN.	TYP.	MAX.	MIN.	TYP.	MAX.
a1		0.63			0.025	
b		0.45			0.018	
b1	0.23		0.31	0.009		0.012
b2		1.27			0.050	
D			32.2			1.268
E	15.2		16.68	0.598		0.657
e		2.54			0.100	
e3		27.94			1.100	
F			14.1			0.555
l		4.445			0.175	
L		3.3			0.130	

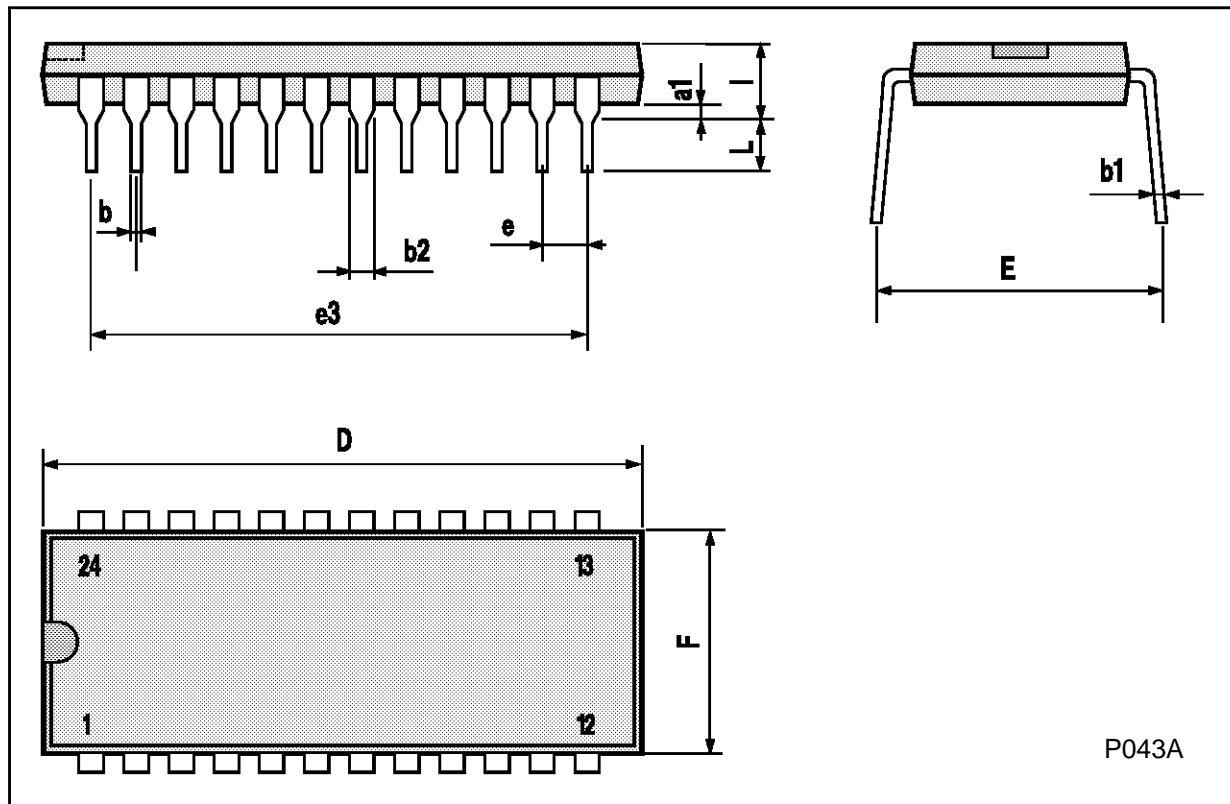

**SO24 MECHANICAL DATA**

DIM.	mm			inch		
	MIN.	TYP.	MAX.	MIN.	TYP.	MAX.
A			2.65			0.104
a1	0.10		0.20	0.004		0.007
a2			2.45			0.096
b	0.35		0.49	0.013		0.019
b1	0.23		0.32	0.009		0.012
C		0.50			0.020	
c1	45° (typ.)					
D	15.20		15.60	0.598		0.614
E	10.00		10.65	0.393		0.420
e		1.27			0.05	
e3		13.97			0.55	
F	7.40		7.60	0.291		0.299
L	0.50		1.27	0.19		0.050
S	8° (max.)					

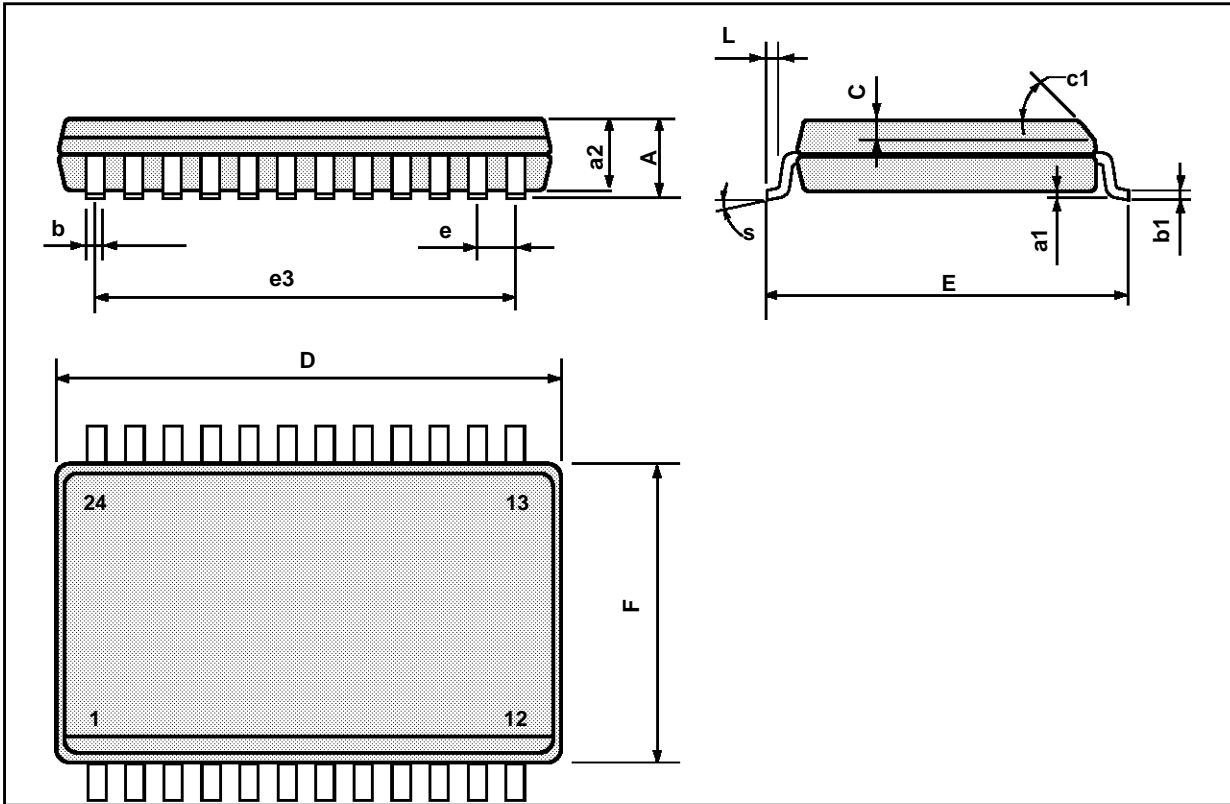

Information furnished is believed to be accurate and reliable. However, SGS-THOMSON Microelectronics assumes no responsibility for the consequences of use of such information nor for any infringement of patents or other rights of third parties which may result from its use. No license is granted by implication or otherwise under any patent or patent rights of SGS-THOMSON Microelectronics. Specifications mentioned in this publication are subject to change without notice. This publication supersedes and replaces all information previously supplied. SGS-THOMSON Microelectronics products are not authorized for use as critical components in life support devices or systems without express written approval of SGS-THOMSON Microelectronics.

© 1994 SGS-THOMSON Microelectronics - All Rights Reserved

SGS-THOMSON Microelectronics GROUP OF COMPANIES

Australia - Brazil - France - Germany - Hong Kong - Italy - Japan - Korea - Malaysia - Malta - Morocco - The Netherlands -  
Singapore - Spain - Sweden - Switzerland - Taiwan - Thailand - United Kingdom - U.S.A