

QUAD 2-INPUT NOR GATE

- **HIGH SPEED**
 $t_{PD} = 11 \text{ ns (TYP.) AT } V_{CC} = 5 \text{ V}$
- **LOW POWER DISSIPATION**
 $I_{CC} = 1 \mu\text{A (MAX.) AT } T_A = 25 \text{ }^\circ\text{C}$
- **COMPATIBLE WITH TTL OUTPUTS**
 $V_{IH} = 2\text{V (MIN.) } V_{IL} = 0.8\text{V (MAX)}$
- **OUTPUT DRIVE CAPABILITY**
10 LSTTL LOADS
- **SYMMETRICAL OUTPUT IMPEDANCE**
 $|I_{OH}| = I_{OL} = 4 \text{ mA (MIN.)}$
- **BALANCED PROPAGATION DELAYS**
 $t_{PLH} = t_{PHL}$
- **PIN AND FUNCTION COMPATIBLE**
WITH 54/74LS02

DESCRIPTION

The M54/74HCT02 is a high speed CMOS QUAD 2-INPUT NOR GATE fabricated in silicon gate C²MOS technology. It has the same high speed performance of LSTTL combined with true CMOS low power consumption. The internal circuit is composed of 3 stages including buffer output, which gives high noise immunity and stable output. All inputs are equipped with protection circuits against static discharge and transient excess voltage.

This integrated circuit has input and output characteristics that are fully compatible with 54/74 LSTTL logic families. M54/74HCT devices are designed to directly interface HSC²MOS systems with TTL and NMOS components. They are also plug in replacements for LSTTL devices giving a reduction of power consumption.

INPUT AND OUTPUT EQUIVALENT CIRCUIT

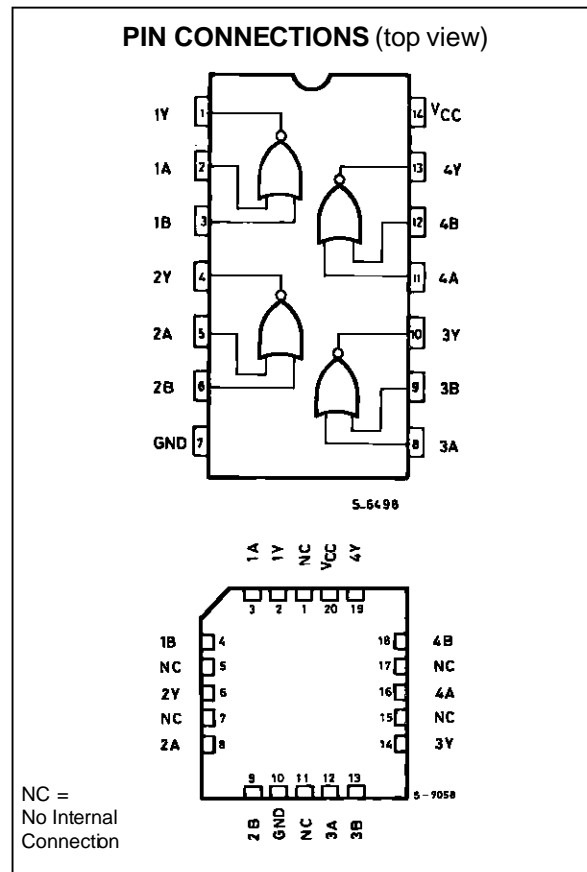
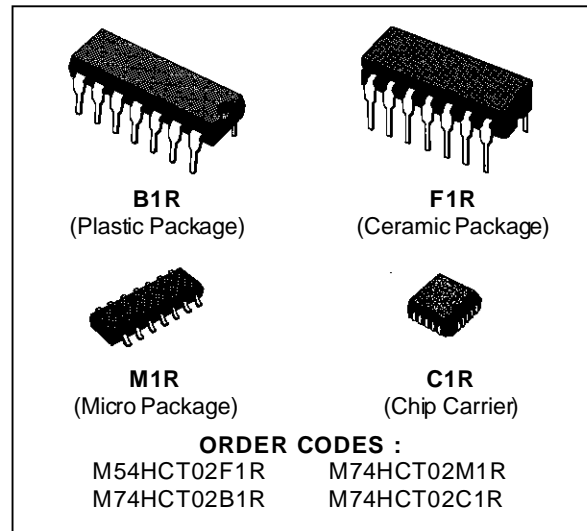
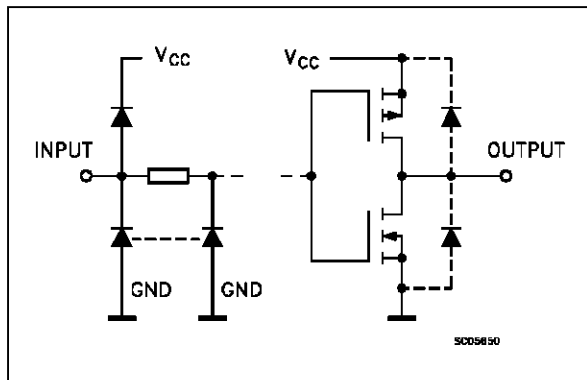

M54/M74HCT02

TRUTH TABLE

A	B	Y
L	L	H
L	H	L
H	L	L
H	H	L

PIN DESCRIPTION

PIN No	SYMBOL	NAME AND FUNCTION
2, 5, 8, 11	1A to 4A	Data Inputs
3, 6, 9, 12	1B to 4B	Data Inputs
1, 4, 10, 12	1Y to 4Y	Data Outputs
7	GND	Ground (0V)
14	V _{CC}	Positive Supply Voltage

IEC LOGIC SYMBOL

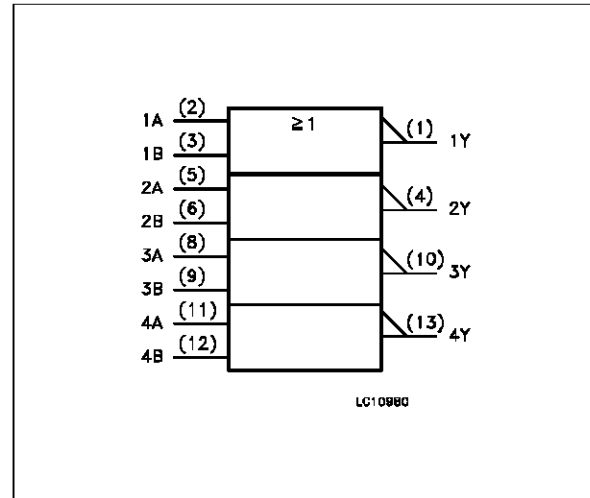

LOGIC DIAGRAM

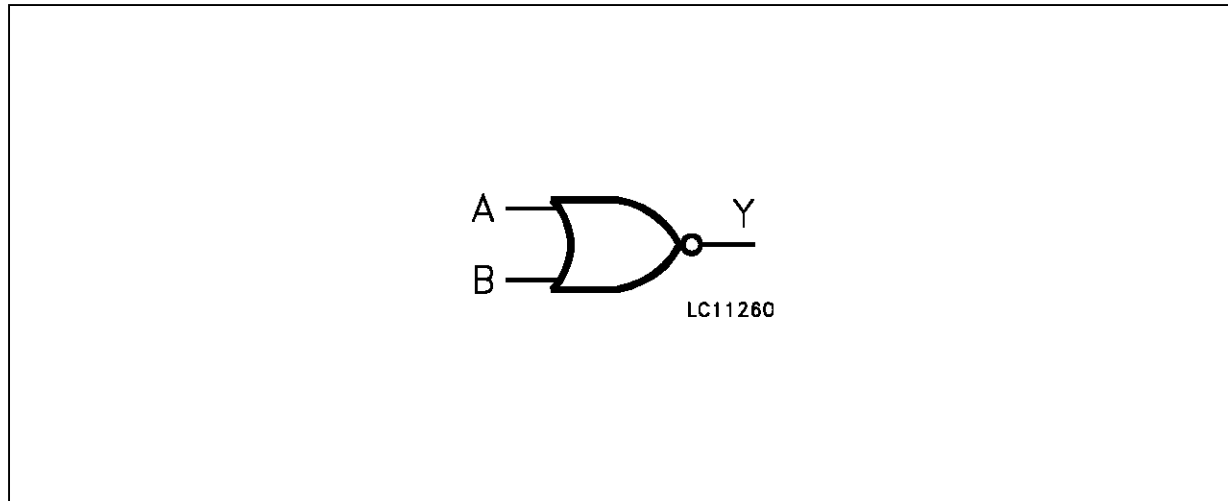

ABSOLUTE MAXIMUM RATINGS

Symbol	Parameter	Value	Unit
V _{CC}	Supply Voltage	-0.5 to +7	V
V _I	DC Input Voltage	-0.5 to V _{CC} + 0.5	V
V _O	DC Output Voltage	-0.5 to V _{CC} + 0.5	V
I _{IK}	DC Input Diode Current	± 20	mA
I _{OK}	DC Output Diode Current	± 20	mA
I _O	DC Output Source Sink Current Per Output Pin	± 25	mA
I _{CC} or I _{GND}	DC V _{CC} or Ground Current	± 50	mA
P _D	Power Dissipation	500 (*)	mW
T _{stg}	Storage Temperature	-65 to +150	°C
T _L	Lead Temperature (10 sec)	300	°C

Absolute Maximum Ratings are those values beyond which damage to the device may occur. Functional operation under these condition is not implied.

(*) 500 mW: ≅ 65 °C derate to 300 mW by 10mW/°C: 65 °C to 85 °C

RECOMMENDED OPERATING CONDITIONS

Symbol	Parameter	Value	Unit
V_{CC}	Supply Voltage	4.5 to 5.5	V
V_I	Input Voltage	0 to V_{CC}	V
V_O	Output Voltage	0 to V_{CC}	V
T_{op}	Operating Temperature: M54HC Series M74HC Series	-55 to +125 -40 to +85	°C °C
t_r, t_f	Input Rise and Fall Time ($V_{CC} = 4.5$ to $5.5V$)	0 to 500	ns

DC SPECIFICATIONS

Symbol	Parameter	Test Conditions		Value						Unit		
		V_{CC} (V)		$T_A = 25\text{ }^\circ\text{C}$ 54HC and 74HC			-40 to $85\text{ }^\circ\text{C}$ 74HC		-55 to $125\text{ }^\circ\text{C}$ 54HC			
				Min.	Typ.	Max.	Min.	Max.	Min.		Max.	
V_{IH}	High Level Input Voltage	4.5 to 5.5		2.0			2.0		2.0		V	
V_{IL}	Low Level Input Voltage	4.5 to 5.5				0.8		0.8		0.8	V	
V_{OH}	High Level Output Voltage	4.5	$V_I = V_{IH}$ or V_{IL}	$I_O = -20\text{ }\mu\text{A}$	4.4	4.5		4.4		4.4		V
				$I_O = -4.0\text{ mA}$	4.18	4.31		4.13		4.10		
V_{OL}	Low Level Output Voltage	4.5	$V_I = V_{IH}$ or V_{IL}	$I_O = 20\text{ }\mu\text{A}$		0.0	0.1		0.1		0.1	V
				$I_O = 4.0\text{ mA}$		0.17	0.26		0.33		0.4	
I_I	Input Leakage Current	5.5	$V_I = V_{CC}$ or GND				± 0.1		± 1		± 1	μA
I_{CC}	Quiescent Supply Current	5.5	$V_I = V_{CC}$ or GND				1		10		20	μA
ΔI_{CC}	Additional worst case supply current	5.5	Per Input pin $V_I = 0.5V$ or $V_I = 2.4V$ Other Inputs at V_{CC} or GND $I_O = 0$				2.0		2.9		3.0	mA

M54/M74HCT02

AC ELECTRICAL CHARACTERISTICS ($C_L = 50 \text{ pF}$, Input $t_r = t_f = 6 \text{ ns}$)

Symbol	Parameter	Test Conditions		Value						Unit	
		V_{CC} (V)		$T_A = 25 \text{ }^\circ\text{C}$ 54HC and 74HC			$-40 \text{ to } 85 \text{ }^\circ\text{C}$ 74HC		$-55 \text{ to } 125 \text{ }^\circ\text{C}$ 54HC		
				Min.	Typ.	Max.	Min.	Max.	Min.		Max.
t_{TLH} t_{THL}	Output Transition Time	4.5			8	15		19		22	ns
t_{PLH} t_{PHL}	Propagation Delay Time	4.5			15	24		30		36	ns
C_{IN}	Input Capacitance				5	10		10		10	pF
$C_{PD} (*)$	Power Dissipation Capacitance				25						pF

(*) C_{PD} is defined as the value of the IC's internal equivalent capacitance which is calculated from the operating current consumption without load. (Refer to Test Circuit). Average operating current can be obtained by the following equation. $I_{CC(opr)} = C_{PD} \cdot V_{CC} \cdot f_{IN} + I_{CC}/4$ (per Gate)

SWITCHING CHARACTERISTICS TEST CIRCUIT

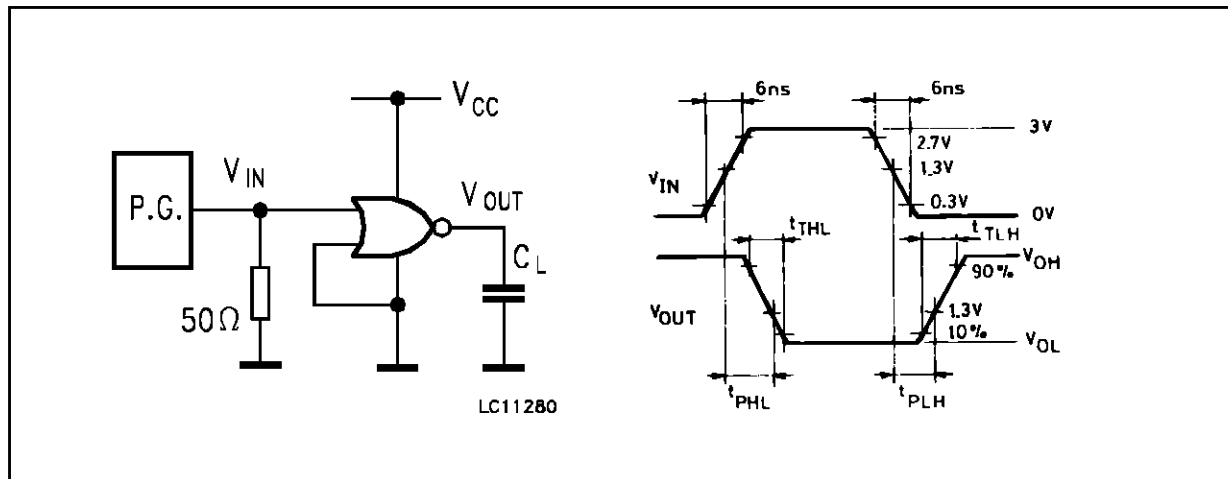

TEST CIRCUIT I_{CC} (Opr.)

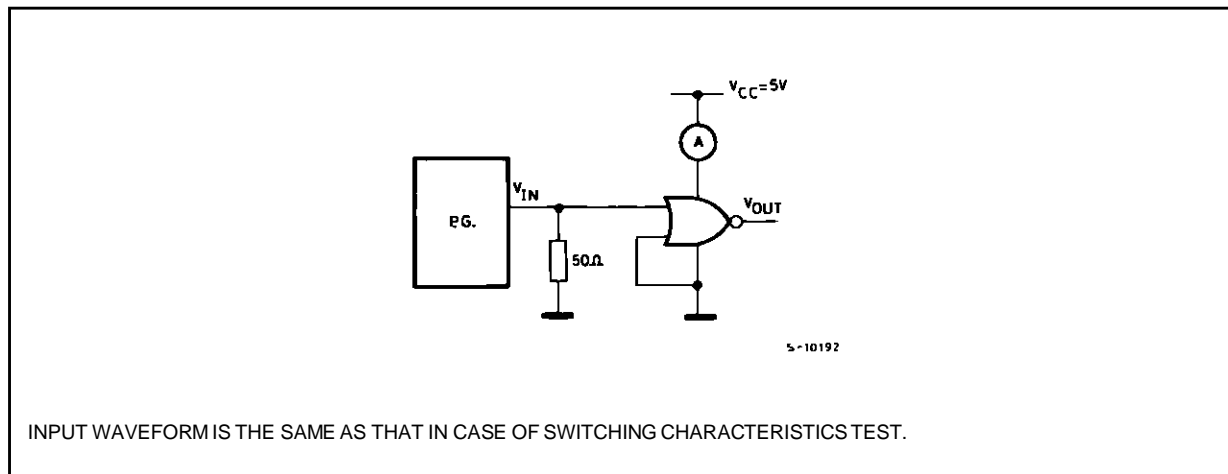

Plastic DIP14 MECHANICAL DATA

DIM.	mm			inch		
	MIN.	TYP.	MAX.	MIN.	TYP.	MAX.
a1	0.51			0.020		
B	1.39		1.65	0.055		0.065
b		0.5			0.020	
b1		0.25			0.010	
D			20			0.787
E		8.5			0.335	
e		2.54			0.100	
e3		15.24			0.600	
F			7.1			0.280
I			5.1			0.201
L		3.3			0.130	
Z	1.27		2.54	0.050		0.100

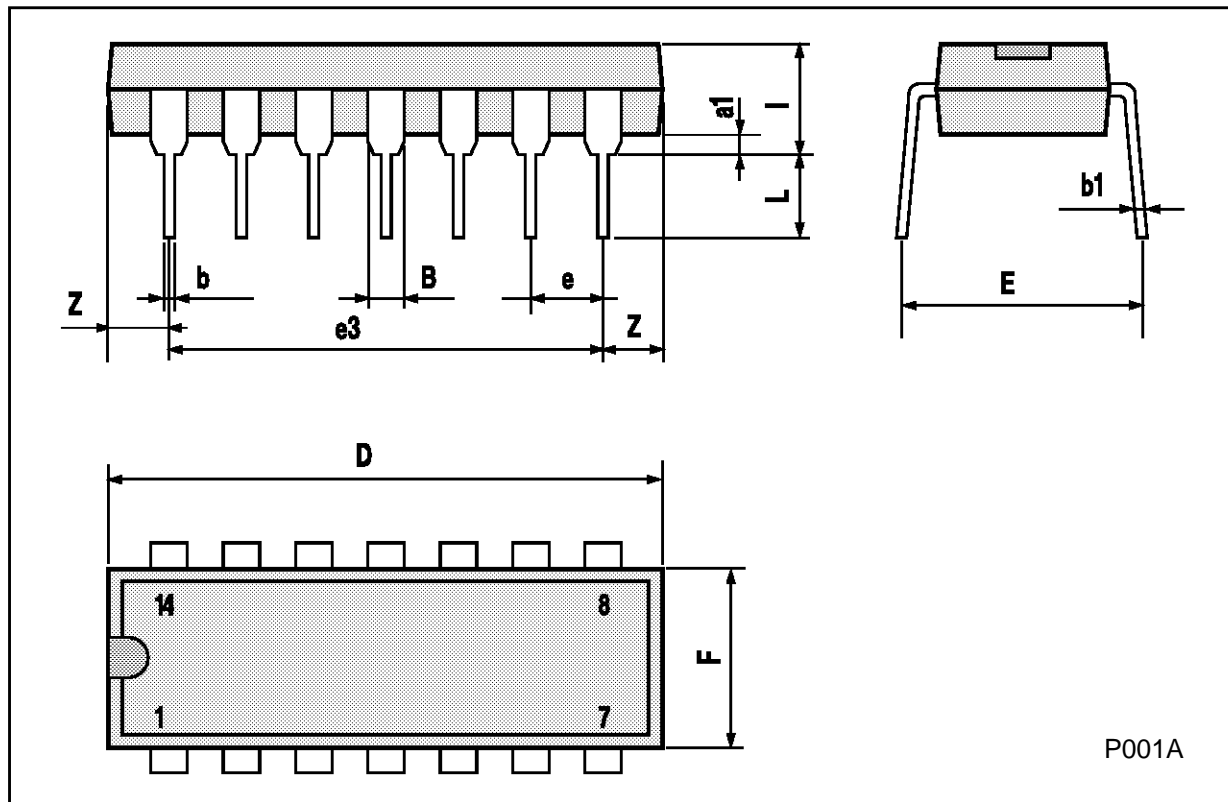

P001A

Ceramic DIP14/1 MECHANICAL DATA

DIM.	mm			inch		
	MIN.	TYP.	MAX.	MIN.	TYP.	MAX.
A			20			0.787
B			7.0			0.276
D		3.3			0.130	
E	0.38			0.015		
e3		15.24			0.600	
F	2.29		2.79	0.090		0.110
G	0.4		0.55	0.016		0.022
H	1.17		1.52	0.046		0.060
L	0.22		0.31	0.009		0.012
M	1.52		2.54	0.060		0.100
N			10.3			0.406
P	7.8		8.05	0.307		0.317
Q			5.08			0.200



P053C

SO14 MECHANICAL DATA

DIM.	mm			inch		
	MIN.	TYP.	MAX.	MIN.	TYP.	MAX.
A			1.75			0.068
a1	0.1		0.2	0.003		0.007
a2			1.65			0.064
b	0.35		0.46	0.013		0.018
b1	0.19		0.25	0.007		0.010
C		0.5			0.019	
c1	45° (typ.)					
D	8.55		8.75	0.336		0.344
E	5.8		6.2	0.228		0.244
e		1.27			0.050	
e3		7.62			0.300	
F	3.8		4.0	0.149		0.157
G	4.6		5.3	0.181		0.208
L	0.5		1.27	0.019		0.050
M			0.68			0.026
S	8° (max.)					



PLCC20 MECHANICAL DATA

DIM.	mm			inch		
	MIN.	TYP.	MAX.	MIN.	TYP.	MAX.
A	9.78		10.03	0.385		0.395
B	8.89		9.04	0.350		0.356
D	4.2		4.57	0.165		0.180
d1		2.54			0.100	
d2		0.56			0.022	
E	7.37		8.38	0.290		0.330
e		1.27			0.050	
e3		5.08			0.200	
F		0.38			0.015	
G			0.101			0.004
M		1.27			0.050	
M1		1.14			0.045	



Information furnished is believed to be accurate and reliable. However, SGS-THOMSON Microelectronics assumes no responsibility for the consequences of use of such information nor for any infringement of patents or other rights of third parties which may result from its use. No license is granted by implication or otherwise under any patent or patent rights of SGS-THOMSON Microelectronics. Specifications mentioned in this publication are subject to change without notice. This publication supersedes and replaces all information previously supplied. SGS-THOMSON Microelectronics products are not authorized for use as critical components in life support devices or systems without express written approval of SGS-THOMSON Microelectronics.

© 1994 SGS-THOMSON Microelectronics - All Rights Reserved

SGS-THOMSON Microelectronics GROUP OF COMPANIES

Australia - Brazil - France - Germany - Hong Kong - Italy - Japan - Korea - Malaysia - Malta - Morocco - The Netherlands -
Singapore - Spain - Sweden - Switzerland - Taiwan - Thailand - United Kingdom - U.S.A