

## HCT646 OCTAL BUS TRANSCEIVER/REGISTER (3-STATE)

## HCT648 OCTAL BUS TRANSCEIVER/REGISTER (3-STATE, INV.)

- HIGH SPEED  
 $f_{MAX} = 60 \text{ MHz (TYP.) AT } V_{CC} = 5 \text{ V}$
- LOW POWER DISSIPATION  
 $I_{CC} = 4 \mu\text{A (MAX.) AT } T_A = 25 \text{ }^\circ\text{C}$
- COMPATIBLE WITH TTL OUTPUTS  
 $V_{IH} = 2\text{V (MIN.) } V_{IL} = 0.8\text{V (MAX)}$
- OUTPUT DRIVE CAPABILITY  
 15 LSTTL LOADS
- SYMMETRICAL OUTPUT IMPEDANCE  
 $|I_{OH}| = I_{OL} = 6 \text{ mA (MIN.)}$
- BALANCED PROPAGATION DELAYS  
 $t_{PLH} = t_{PHL}$
- PIN AND FUNCTION COMPATIBLE  
 WITH 54/74LS646/648

### DESCRIPTION

The M74HCT646/648 are high speed CMOS OCTAL BUS TRANSCEIVERS AND REGISTERS, (3-STATE) fabricated in silicon gate CMOS technology. They have the same high speed performance of LSTTL combined with true CMOS low power consumption. These devices consist of bus transceiver circuits with 3-state output, D-type flip-flops, and control circuitry arranged for multiplexed transmission of data directly from the input bus or from the internal registers. Data on the A or B bus will be clocked into the registers on the low-to-high transition of the appropriate clock pin (Clock AB - or Clock BA). Enable ( $\bar{G}$ ) and direction (DIR) pins are provided to control the transceiver functions. In the transceiver mode, data present at the high-impedance port may be stored in either register or in both. The select controls (Select AB select BA) can multiplex stored and real-time (transparent mode) data. The direction control determines which bus will receive data when enable  $\bar{G}$  is active (low). In the isolation mode (enable  $\bar{G}$  high), "A" data may be stored in one register and/or "B" data may be stored in the other register. When an output function is disabled, the input function is still enabled and may be used to store and transmit data. Only one of the two buses, A or B, may be driven at a time. All inputs are equipped with protection circuits against static discharge and transient excess voltage. This integrated circuit has input and output characteristics that are fully compatible with 54/74 LSTTL logic families. M74HCT devices are designed to directly interface HSC<sup>2</sup>MOS systems with TTL and NMOS components. They are also plug in replacements for LSTTL devices giving a reduction of power consumption.

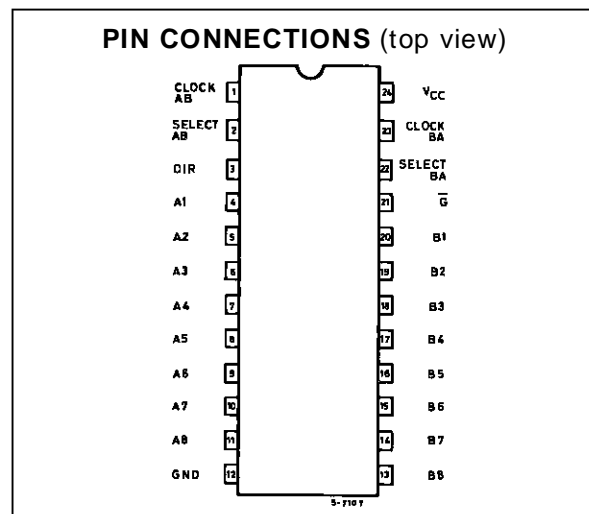
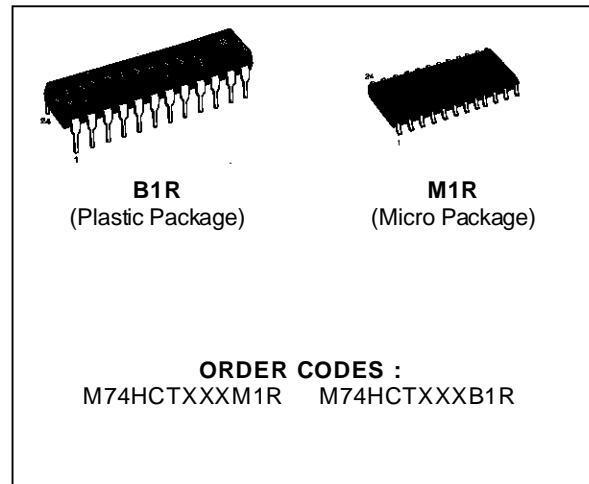

### INPUT AND OUTPUT EQUIVALENT CIRCUIT

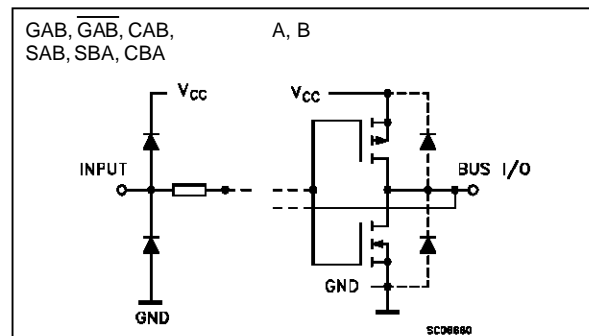

# M74HCT646/648

## LOGIC DIAGRAM (HCT648)

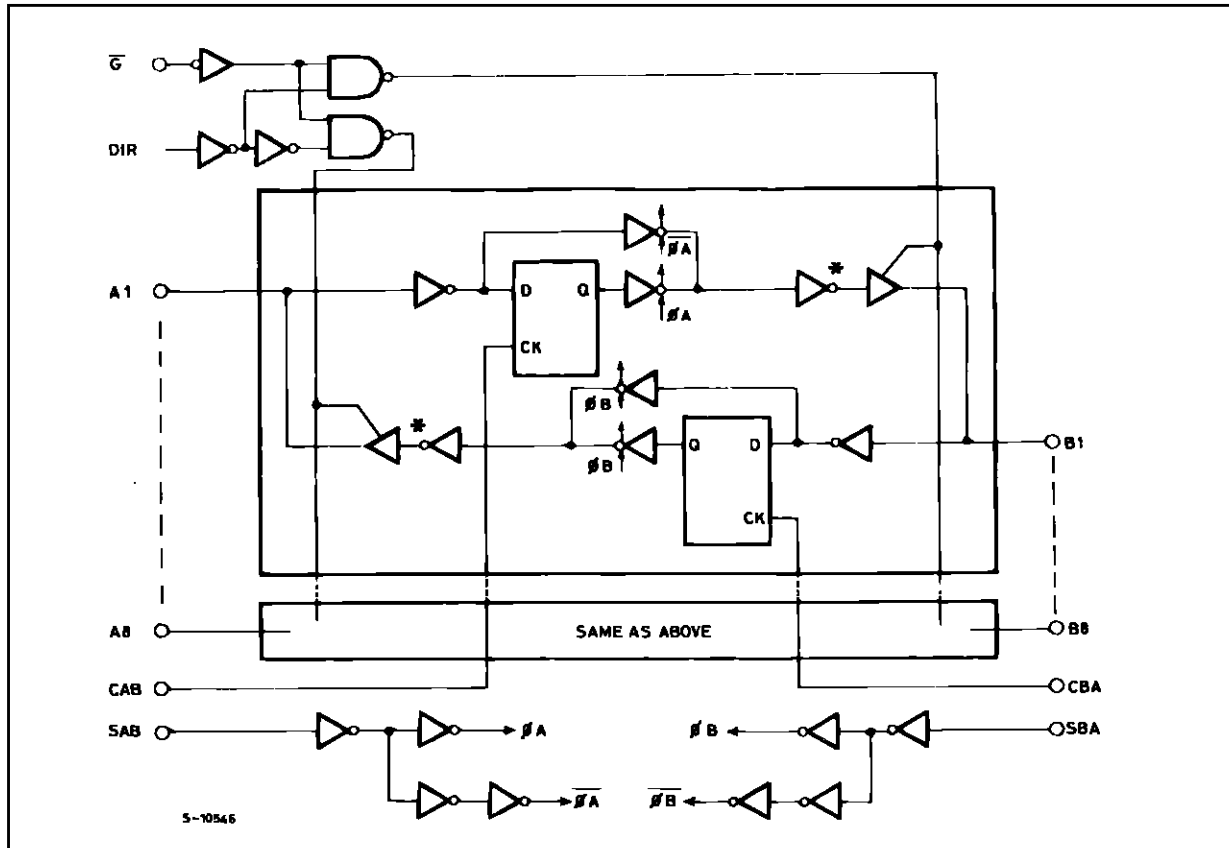

Note : In case of M54/74HCT646 output inverter marked \* at A bus and B bus are eliminated.

## TIMING CHART

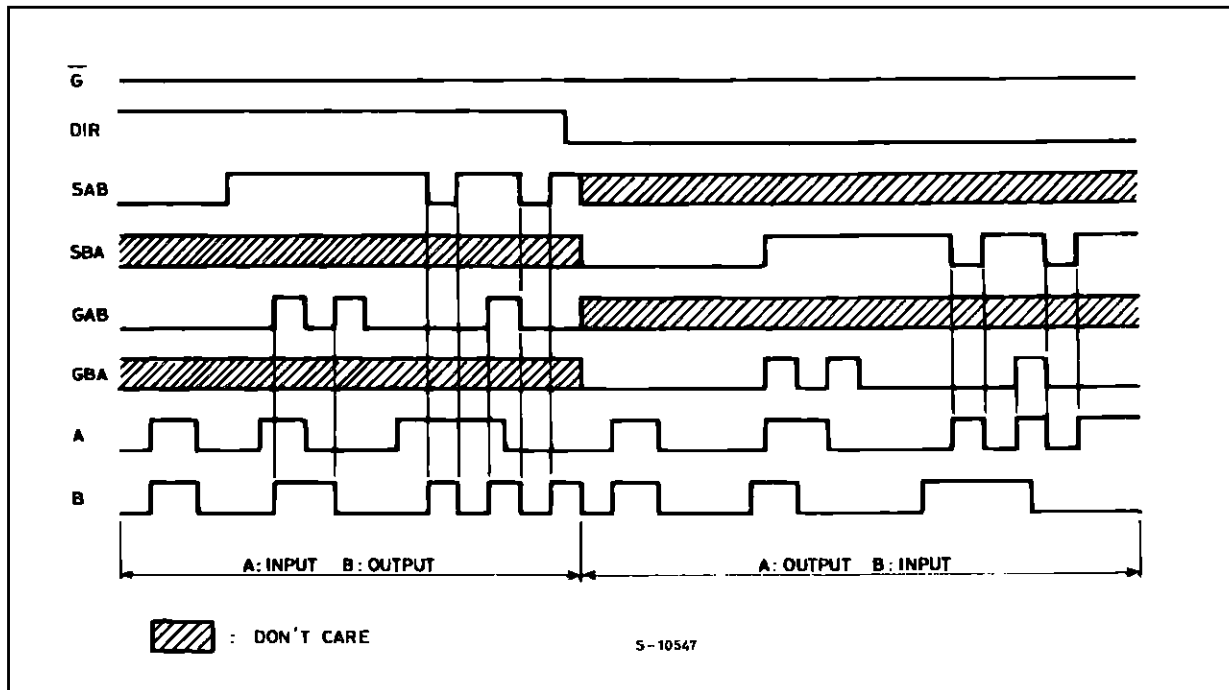

**TRUTH TABLE**

HCT646 (The truth table for HCT648 is the same as this, but with the outputs inverted)

$\overline{G}$	DIR	CAB	CBA	SAB	SBA	A	B	FUNCTION
H	X					INPUTS	INPUTS	Both the A bus and the B bus are inputs
		X	X	X	X	Z	Z	The output functions of the A and B bus are disabled
		$\lceil$	$\lceil$	X	X	INPUTS	INPUTS	Both the A and B bus are used for inputs to the internal flip-flops. Data at the bus will be stored on low to high transition of the clock inputs
L	H					INPUTS	OUTPUTS	The A bus are inputs and the B bus are outputs
		X	X*	L	X	L	L	The data at the A bus are displayed at the B bus
						H	H	
		$\lceil$	X*	L	X	L	L	The data at the A bus are displayed at the B bus. The data of the A bus are stored to the internal flip-flop on low to high transition of the clock pulse.
						H	H	
X	X*	H	X	X	Qn		The data stored to the internal flip-flop are displayed at the B bus	
$\lceil$	X*	H	X	L	L	L	The data at the A bus are stored to the internal flip-flop on low to high transition of the clock pulse. The states of the internal flip-flops output directly to the B bus	
				H	H			
L	L					OUTPUTS	INPUTS	The A bus are outputs and the B bus are inputs
		X*	X	X	L	L	L	The data at the B bus are displayed at the A bus
						H	H	
		X*	$\lceil$	X	L	L	L	The data at the B bus are displayed at the A bus. The data of the B bus are stored to the internal flip-flop on low to high transition of the clock pulse
						H	H	
X*	X	X	H	Qn	X		The data stored to the internal flip-flops are displayed at the B bus	
x*	$\lceil$	X	H	L	L	L	the data at the B bus are stored to the internal flip-flop on low to high transition of the clock pulse. The states of the internal flip-flops output directly to the A bus	
				H	H			

X : DON'T CARE

Z : HIGH IMPEDANCE

Qn : THE DATA STORED TO THE INTERNAL FLIP-FLOPS BY MOST RECENT LOW TO HIGH TRANSITION OF THE CLOCK INPUTS

\* : THE DATA AT THE A AND B BUS WILL BE STORED TO THE INTERNAL FLIP-FLOPS ON EVERY LOW TO HIGH TRANSITION OF THE CLOCK INPUTS

# M74HCT646/648

## PIN DESCRIPTION

PIN No	SYMBOL	NAME AND FUNCTION
1	CLOCK AB	A to B Clock Input (LOW to HIGH, Edge-Triggered)
2	SELECT AB	Select A to B Source Input
3	DIR	Direction Control Input
4, 5, 6, 7, 8, 9, 10, 11	A1 to A8	A data Inputs/Outputs
20, 19, 18, 17, 16, 15, 14, 13	B1 to B8	B Data Inputs/Outputs
21	$\overline{G}$	Output Enable Input (Active LOW)
22	SELECT BA	Select B to A Source Input
23	CLOCK BA	B to A Clock Input (LOW to HIGH, Edge-Triggered)
12	GND	Ground (0V)
24	Vcc	Positive Supply Voltage

## IEC LOGIC SYMBOLS

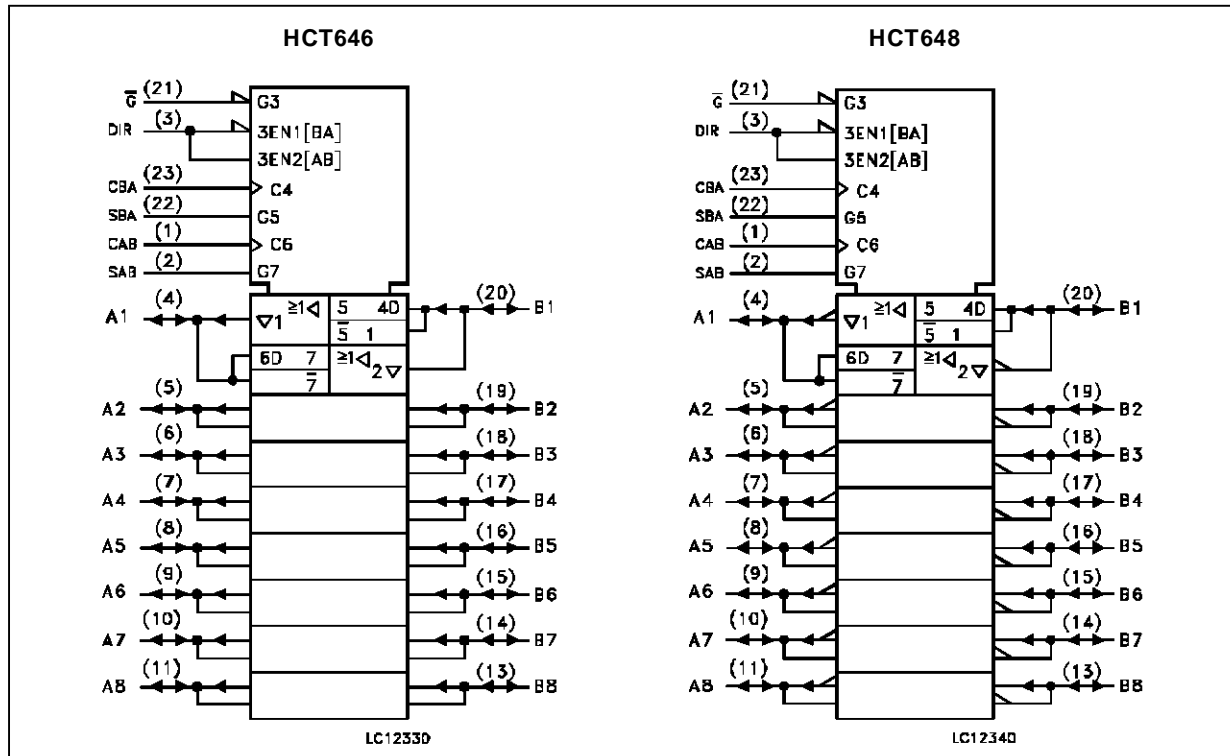

**ABSOLUTE MAXIMUM RATINGS**

Symbol	Parameter	Value	Unit
V <sub>CC</sub>	Supply Voltage	-0.5 to +7	V
V <sub>I</sub>	DC Input Voltage	-0.5 to V <sub>CC</sub> + 0.5	V
V <sub>O</sub>	DC Output Voltage	-0.5 to V <sub>CC</sub> + 0.5	V
I <sub>IK</sub>	DC Input Diode Current	± 20	mA
I <sub>OK</sub>	DC Output Diode Current	± 20	mA
I <sub>O</sub>	DC Output Source Sink Current Per Output Pin	± 35	mA
I <sub>CC</sub> or I <sub>GND</sub>	DC V <sub>CC</sub> or Ground Current	± 70	mA
P <sub>D</sub>	Power Dissipation	500 (*)	mW
T <sub>stg</sub>	Storage Temperature	-65 to +150	°C
T <sub>L</sub>	Lead Temperature (10 sec)	300	°C

Absolute Maximum Ratings are those values beyond which damage to the device may occur. Functional operation under these condition is not implied.

(\*) 500 mW: ≡ 65 °C derate to 300 mW by 10mW/°C: 65 °C to 85 °C

**RECOMMENDED OPERATING CONDITIONS**

Symbol	Parameter	Value	Unit
V <sub>CC</sub>	Supply Voltage	4.5 to 5.5	V
V <sub>I</sub>	Input Voltage	0 to V <sub>CC</sub>	V
V <sub>O</sub>	Output Voltage	0 to V <sub>CC</sub>	V
T <sub>op</sub>	Operating Temperature	-40 to +85	°C
t <sub>r</sub> , t <sub>f</sub>	Input Rise and Fall Time (V <sub>CC</sub> = 4.5 to 5.5V)	0 to 500	ns

**DC SPECIFICATIONS**

Symbol	Parameter	Test Conditions		Value					Unit	
		V <sub>CC</sub> (V)		T <sub>A</sub> = 25 °C			-40 to 85 °C			
				Min.	Typ.	Max.	Min.	Max.		
V <sub>IH</sub>	High Level Input Voltage	4.5 to 5.5		2.0			2.0		V	
V <sub>IL</sub>	Low Level Input Voltage	4.5 to 5.5				0.8		0.8	V	
V <sub>OH</sub>	High Level Output Voltage	4.5	V <sub>I</sub> = V <sub>IH</sub> or V <sub>IL</sub>	I <sub>O</sub> = -20 μA	4.4	4.5		4.4		V
				I <sub>O</sub> = -6.0 mA	4.18	4.31		4.13		
V <sub>OL</sub>	Low Level Output Voltage	4.5	V <sub>I</sub> = V <sub>IH</sub> or V <sub>IL</sub>	I <sub>O</sub> = 20 μA		0.0	0.1		0.1	V
				I <sub>O</sub> = 6.0 mA		0.17	0.26		0.33	
I <sub>I</sub>	Input Leakage Current (*)	5.5	V <sub>I</sub> = V <sub>CC</sub> or GND			±0.1		±1	μA	
I <sub>CC</sub>	Quiescent Supply Current	5.5	V <sub>I</sub> = V <sub>CC</sub> or GND			4		40	μA	
I <sub>OZ</sub>	Output Off-state Current	5.5	V <sub>O</sub> = V <sub>CC</sub> or GND V <sub>I</sub> = V <sub>IH</sub> or V <sub>IL</sub>			æ0.5		±5	μA	
ΔI <sub>CC</sub>	Additional worst case supply current	5.5	Per Input pin V <sub>I</sub> = 0.5V or V <sub>I</sub> = 2.4V Other Inputs at V <sub>CC</sub> or GND I <sub>O</sub> = 0			2.0		2.9	mA	

(\*): Applicable only to DIR,  $\bar{G}$ , CAB, CBA, SBA input.

AC ELECTRICAL CHARACTERISTICS ( $C_L = 50$  pF, Input  $t_r = t_f = 6$  ns)

Symbol	Parameter	Test Conditions			Value					Unit
		V <sub>CC</sub> (V)	C <sub>L</sub> (pF)		T <sub>A</sub> = 25 °C 54HC and 74HC			-40 to 85 °C 74HC		
					Min.	Typ.	Max.	Min.	Max.	
t <sub>TLH</sub> t <sub>THL</sub>	Output Transition Time	4.5	50			7	12		15	ns
t <sub>PLH</sub> t <sub>PHL</sub>	Propagation Delay Time (BUS - BUS)	4.5	50			20	30		38	ns
		4.5	150			25	38		48	ns
t <sub>PLH</sub> t <sub>PHL</sub>	Propagation Delay Time (CLOCK - BUS)	4.5	50			29	44		55	ns
		4.5	150			34	52		65	ns
t <sub>PLH</sub> t <sub>PHL</sub>	Propagation Delay Time (SELECT - BUS)	4.5	50			24	34		43	ns
		4.5	150			29	42		53	ns
t <sub>PZL</sub> t <sub>PZH</sub>	3-State Output Enable Time ( $\bar{G}$ , DIR - BUS)	4.5	50	R <sub>L</sub> = 1 K $\Omega$		26	38		48	ns
		4.5	150	R <sub>L</sub> = 1 K $\Omega$		31	46		58	ns
t <sub>PLZ</sub> t <sub>PHZ</sub>	3-State Output Disable Time ( $\bar{G}$ , DIR - BUS)	4.5	50	R <sub>L</sub> = 1 K $\Omega$		26	35		44	ns
f <sub>MAX</sub>	Maximum Clock Frequency	4.5	50		31	55		25		MHz
t <sub>W(H)</sub> t <sub>W(L)</sub>	Minimum Pulse Width	4.5	50			8	15		19	ns
t <sub>s</sub>	Minimum Set-up Time	4.5	50			3	10		13	ns
t <sub>h</sub>	Minimum Hold Time	4.5	50				5		5	ns
C <sub>IN</sub>	Input Capacitance					5	10		10	pF
C <sub>I/O</sub>	Bus Terminal Capacitance					13				pF
C <sub>PD</sub> (*)	Power Dissipation Capacitance			for HCT646 for HCT648		40 39				pF

(\*) C<sub>PD</sub> is defined as the value of the IC's internal equivalent capacitance which is calculated from the operating current consumption without load. (Refer to Test Circuit). Average operating current can be obtained by the following equation. I<sub>CC(opr)</sub> = C<sub>PD</sub> • V<sub>CC</sub> • f<sub>IN</sub> + I<sub>CC</sub>/8 (per bit)

SWITCHING CHARACTERISTICS TEST CIRCUIT AND WAVEFORM

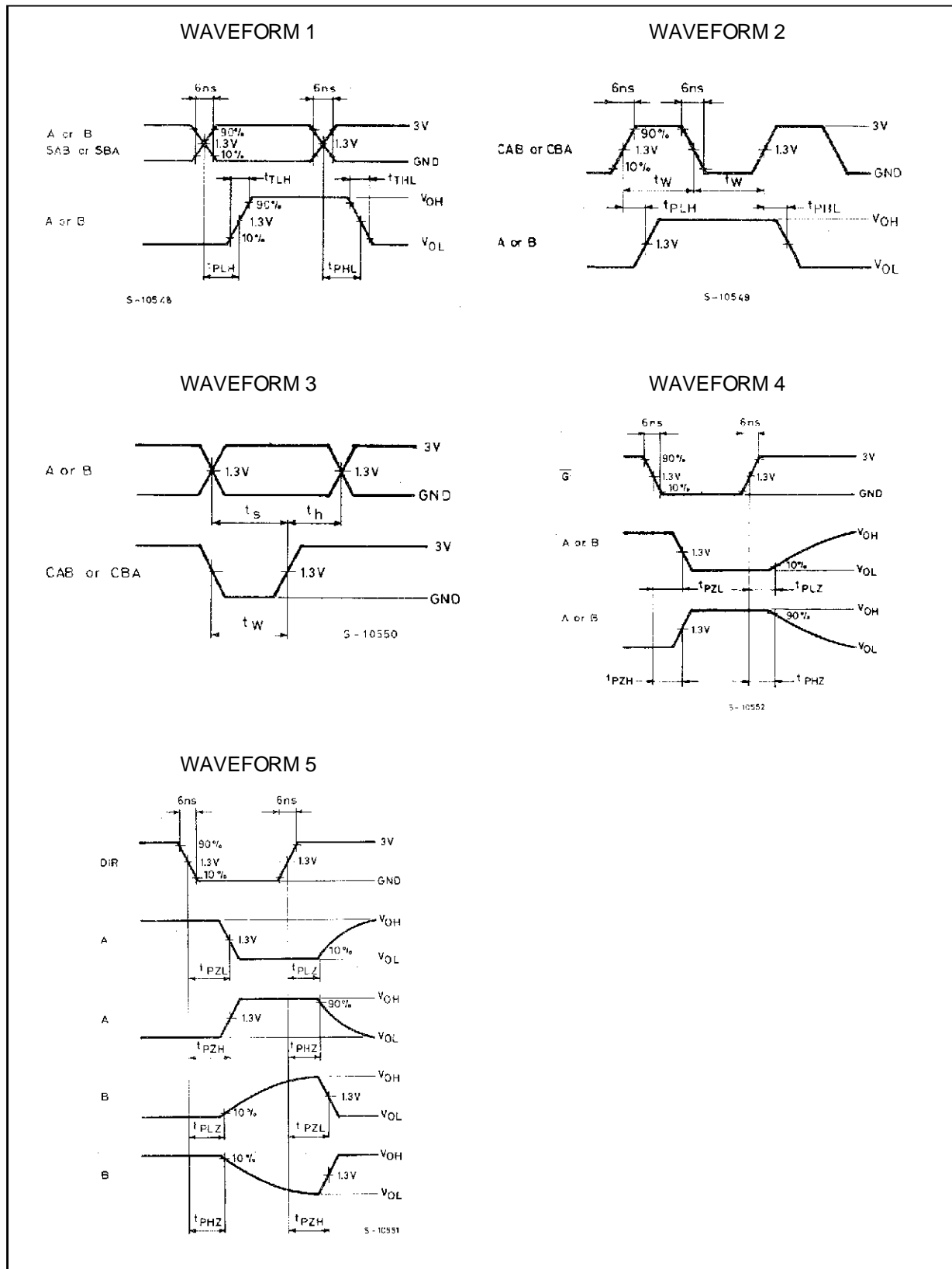

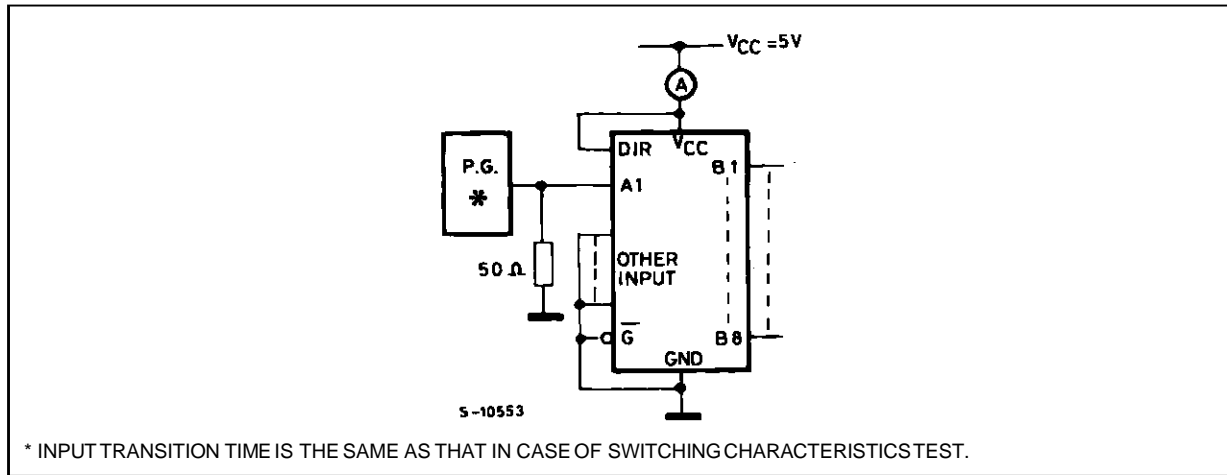
TEST WAVEFORM  $I_{cc}$  (Opr.)

**Plastic DIP24 (0.25) MECHANICAL DATA**

DIM.	mm			inch		
	MIN.	TYP.	MAX.	MIN.	TYP.	MAX.
a1		0.63			0.025	
b		0.45			0.018	
b1	0.23		0.31	0.009		0.012
b2		1.27			0.050	
D			32.2			1.268
E	15.2		16.68	0.598		0.657
e		2.54			0.100	
e3		27.94			1.100	
F			14.1			0.555
l		4.445			0.175	
L		3.3			0.130	

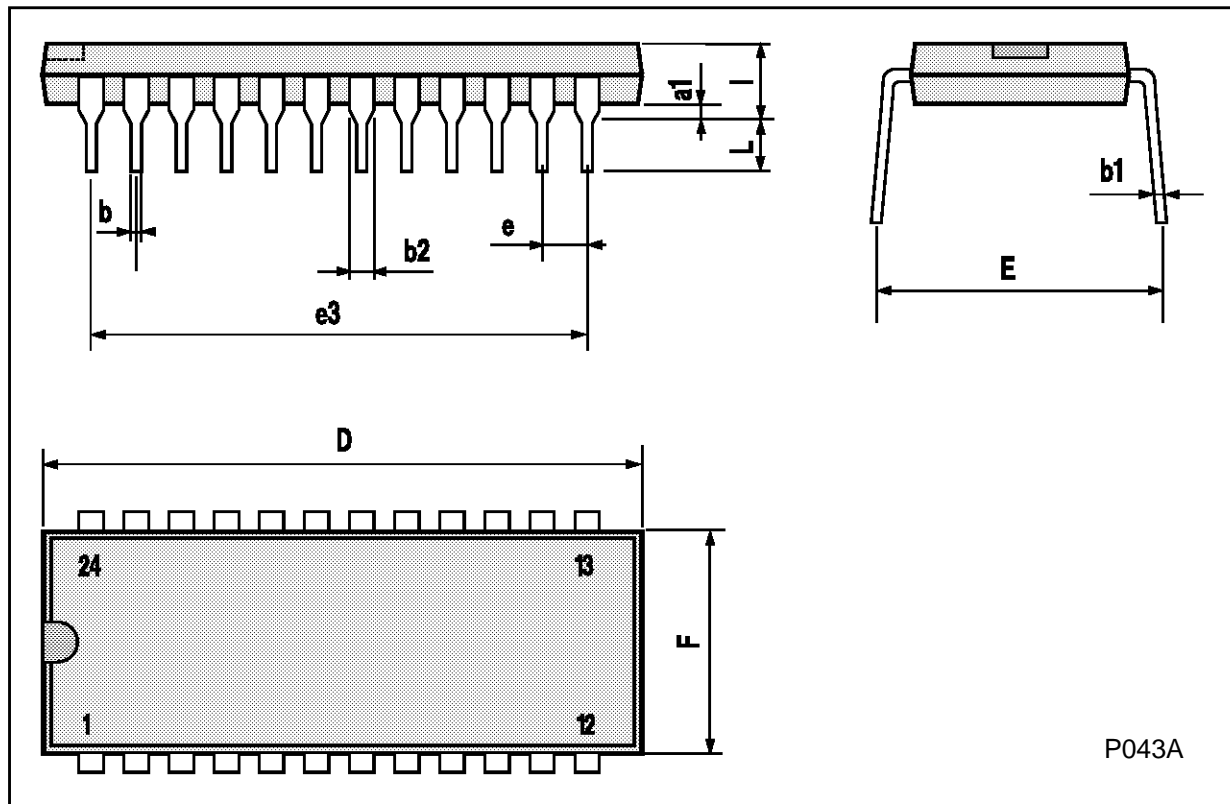

## SO24 MECHANICAL DATA

DIM.	mm			inch		
	MIN.	TYP.	MAX.	MIN.	TYP.	MAX.
A			2.65			0.104
a1	0.10		0.20	0.004		0.007
a2			2.45			0.096
b	0.35		0.49	0.013		0.019
b1	0.23		0.32	0.009		0.012
C		0.50			0.020	
c1	45° (typ.)					
D	15.20		15.60	0.598		0.614
E	10.00		10.65	0.393		0.420
e		1.27			0.05	
e3		13.97			0.55	
F	7.40		7.60	0.291		0.299
L	0.50		1.27	0.19		0.050
S	8° (max.)					

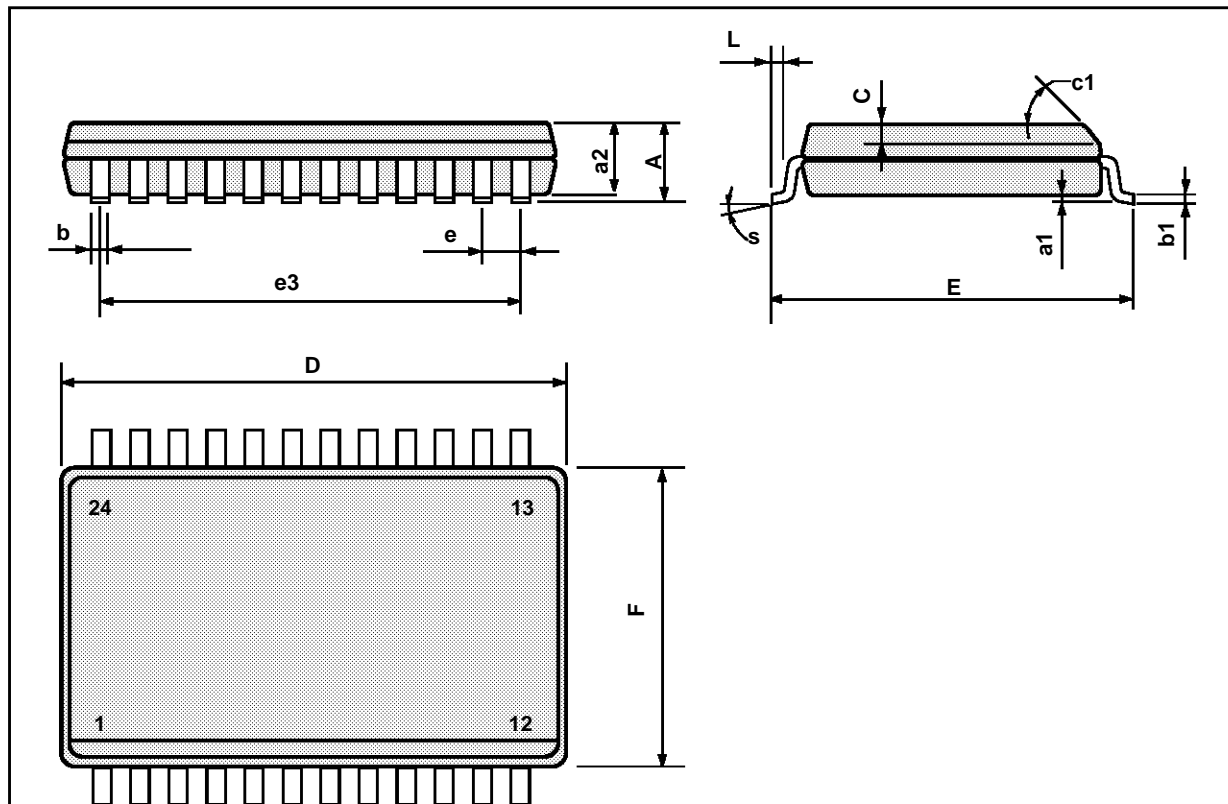

Information furnished is believed to be accurate and reliable. However, SGS-THOMSON Microelectronics assumes no responsibility for the consequences of use of such information nor for any infringement of patents or other rights of third parties which may result from its use. No license is granted by implication or otherwise under any patent or patent rights of SGS-THOMSON Microelectronics. Specifications mentioned in this publication are subject to change without notice. This publication supersedes and replaces all information previously supplied. SGS-THOMSON Microelectronics products are not authorized for use as critical components in life support devices or systems without express written approval of SGS-THOMSON Microelectronics.

© 1994 SGS-THOMSON Microelectronics - All Rights Reserved

SGS-THOMSON Microelectronics GROUP OF COMPANIES

Australia - Brazil - France - Germany - Hong Kong - Italy - Japan - Korea - Malaysia - Malta - Morocco - The Netherlands -  
Singapore - Spain - Sweden - Switzerland - Taiwan - Thailand - United Kingdom - U.S.A