

## 8 x 8 Video Crosspoint Switch

### General Description

The MAX456 is the first monolithic CMOS 8 x 8 video crosspoint switch that significantly reduces component count, board space, and cost. The crosspoint switch contains a digitally controlled matrix of 64 T-switches that connect eight video input signals to any, or all, output channels. Each matrix output connects to eight internal, high-speed (250V/ $\mu$ s), unity-gain-stable buffers capable of driving 400 $\Omega$  and 20pF to  $\pm 1.3$ V. For applications requiring increased drive capability, the MAX456 outputs can be connected directly to two MAX470 quad, gain-of-two video buffers, which are capable of driving 75 $\Omega$  loads.

Three-state output capability and internal, programmable active loads make it feasible to parallel multiple MAX456s and form larger switch matrices.

In the 40-pin DIP package, crosstalk (70dB at 5MHz) is minimized, and board area and complexity are simplified by using a straight-through pinout. The analog inputs and outputs are on opposite sides, and each channel is separated by a power-supply line or quiet digital logic line.

### Applications

Video Test Equipment  
Video Security Systems  
Video Editing

### Typical Application Circuit

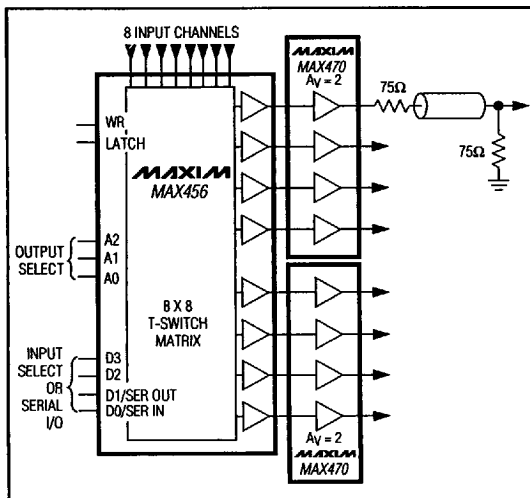

### Features

- ◆ Routes Any Input Channel to Any Output Channel
- ◆ Switches Standard Video Signals
- ◆ Serial or Parallel Digital Interface
- ◆ Expandable for Larger Switch Matrices
- ◆ 80dB All-Channel Off Isolation at 5MHz
- ◆ 8 Internal Buffers with:  
250V/ $\mu$ s Slew Rate, Three-State Output Capability,  
Power-Saving Disable Feature, 35MHz Bandwidth

### Ordering Information

PART	TEMP. RANGE	PIN-PACKAGE
MAX456CPL	0°C to +70°C	40 Plastic DIP
MAX456CQH	0°C to +70°C	44 PLCC
MAX456C/D	0°C to +70°C	Dice*

Ordering information continued on last page.

\* Dice are specified at  $T_A = +25^\circ\text{C}$ , DC parameters only.

### Pin Configurations

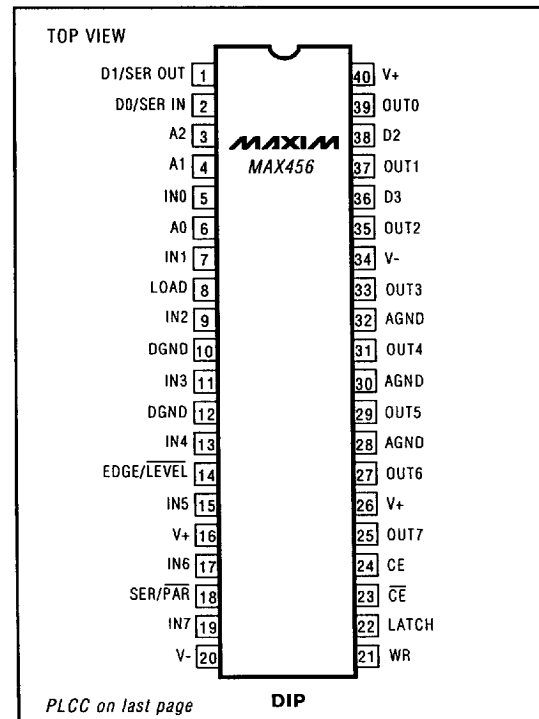

Maxim Integrated Products 1

Call toll free 1-800-998-8800 for free samples or literature.

■ 5876651 0010710 82T ■

# 8 x 8 Video Crosspoint Switch

## ABSOLUTE MAXIMUM RATINGS

Total Supply Voltage (V+ to V-) .....+12V  
 Positive Supply Voltage V+ Referred to AGND.....-0.3V to +12V  
 Negative Supply Voltage V- Referred to AGND.....-12V to +0.3V  
 DGND Voltage.....AGND  $\pm$ 0.3V  
 Buffer Short Circuit to Ground when  
   Not Exceeding Package Power Dissipation.....Indefinite  
 Analog Input Voltage.....(V+ + 0.3V) to (V- - 0.3V)  
 Digital Input Voltage.....(V+ + 0.3V) to (V- - 0.3V)  
 Input Current, Power On or Off  
   Digital Inputs..... $\pm$ 20mA  
   Analog Inputs..... $\pm$ 50mA

Continuous Power Dissipation ( $T_A = +70^\circ\text{C}$ )  
 40-Pin Plastic DIP (derate 11.3mW/ $^\circ\text{C}$  above +70 $^\circ\text{C}$ )....889mW  
 40-Pin CERDIP (derate 20.0mW/ $^\circ\text{C}$  above +70 $^\circ\text{C}$ )....1600mW  
 44-Pin PLCC (derate 13.3mW/ $^\circ\text{C}$  above +70 $^\circ\text{C}$ ) .....1066mW  
 Operating Temperature Ranges:  
   MAX456C \_ \_ .....0 $^\circ\text{C}$  to +70 $^\circ\text{C}$   
   MAX456E \_ \_ .....-40 $^\circ\text{C}$  to +85 $^\circ\text{C}$   
 Storage Temperature Range.....-65 $^\circ\text{C}$  to +160 $^\circ\text{C}$   
 Lead Temperature (soldering, 10 sec) .....+300 $^\circ\text{C}$

Stresses beyond those listed under "Absolute Maximum Ratings" may cause permanent damage to the device. These are stress ratings only, and functional operation of the device at these or any other conditions beyond those indicated in the operational sections of the specifications is not implied. Exposure to absolute maximum rating conditions for extended periods may affect device reliability.

## ELECTRICAL CHARACTERISTICS

(V+ = 5.0V, V- = -5.0V, -1.3V  $\leq$  V<sub>IN</sub>  $\leq$  +1.3V; LOAD = +5V; internal load resistors on; AGND = DGND = 0V; T<sub>A</sub> = +25 $^\circ\text{C}$ , unless otherwise noted.)

PARAMETER	CONDITIONS		MIN	TYP	MAX	UNITS
Input Voltage Range			-1.3		1.3	V
Voltage Gain	Internal load resistors on, no external load, V <sub>IN</sub> = 0V to 1V	T <sub>A</sub> = +25 $^\circ\text{C}$	0.99	1.0	1.01	V/V
		T <sub>A</sub> = T <sub>MIN</sub> to T <sub>MAX</sub>	0.98	1.0	1.02	
Buffer Offset Voltage	T <sub>A</sub> = +25 $^\circ\text{C}$					$\pm$ 7
	T <sub>A</sub> = T <sub>MIN</sub> to T <sub>MAX</sub>					$\pm$ 12
Offset Voltage Drift	T <sub>A</sub> = T <sub>MIN</sub> to T <sub>MAX</sub>					20
Operating Supply Voltage			$\pm$ 4.5		$\pm$ 5.5	V
Supply Current, All Buffers On (No External Load)	T <sub>A</sub> = +25 $^\circ\text{C}$					39
	T <sub>A</sub> = T <sub>MIN</sub> to T <sub>MAX</sub>					45
Supply Current, All Buffers Off	T <sub>A</sub> = +25 $^\circ\text{C}$					1.5
	T <sub>A</sub> = T <sub>MIN</sub> to T <sub>MAX</sub>					3.0
Power-Supply Rejection Ratio	$\pm$ 4.5V to $\pm$ 5.5V, DC measurement		50	64		dB
Analog Input Current	T <sub>A</sub> = T <sub>MIN</sub> to T <sub>MAX</sub>					$\pm$ 0.1
Output Leakage Current	Internal load resistors off, all buffers off, T <sub>A</sub> = T <sub>MIN</sub> to T <sub>MAX</sub>					$\pm$ 100
Internal Amplifier Load Resistor (LOAD Pin = 5V)	T <sub>A</sub> = +25 $^\circ\text{C}$		250	400	600	$\Omega$
	T <sub>A</sub> = T <sub>MIN</sub> to T <sub>MAX</sub>		200		765	
Buffer Output Voltage Swing	Internal load resistors on, no external load					$\pm$ 1.3
Digital Input Current	T <sub>A</sub> = T <sub>MIN</sub> to T <sub>MAX</sub>					$\pm$ 1
Output Impedance at DC						10
Input Logic Low Threshold						0.8
Input Logic High Threshold						2.4
SER OUT Output Logic Low	Serial mode, SER/PAR = 5V	I <sub>OL</sub> = 1.6mA				0.4
SER OUT Output Logic High		I <sub>OH</sub> = -0.4mA				4

## 8 x 8 Video Crosspoint Switch

### ELECTRICAL CHARACTERISTICS

( $V_+ = 5.0V$ ,  $V_- = -5.0V$ ,  $-1.3V \leq V_{IN} \leq +1.3V$ ,  $LOAD = +5V$ , internal load resistors on,  $AGND = DGND = 0V$ ,  $T_A = +25^\circ C$ , unless otherwise noted.)

PARAMETER	CONDITIONS	MIN	TYP	MAX	UNITS
<b>DYNAMIC SPECIFICATIONS (Note 1)</b>					
Output-Buffer Slew Rate	Internal load resistors on, 10pF load		250		V/ $\mu$ s
Single-Channel Crosstalk	5MHz, $V_{IN} = 2V_{P-P}$ (Note 2)	60	70		dB
All-Channel Crosstalk	5MHz, $V_{IN} = 2V_{P-P}$ (Notes 2, 3)		57		dB
All-Channel Off Isolation	5MHz, $V_{IN} = 2V_{P-P}$ (Note 2)		80		dB
-3dB Bandwidth	10pF load, $V_{IN} = 2V_{P-P}$ (Note 2)	25	35		MHz
Differential Phase Error	(Note 4)		1.0		deg
Differential Gain Error	(Note 4)		0.5		%
Input Noise	DC to 40MHz		0.3	1.0	mV <sub>RMS</sub>
Input Capacitance	All buffer inputs grounded		6		pF
Buffer Input Capacitance	Additional capacitance for each output buffer connected to channel input		2		pF
Output Capacitance	Output buffer off		7		pF

### SWITCHING CHARACTERISTICS (Note 1)

(Figure 4,  $V_+ = 5.0V$ ,  $V_- = -5.0V$ ,  $-1.3V \leq V_{IN} \leq +1.3V$ ,  $LOAD = +5V$ , internal load resistors on,  $AGND = DGND = 0V$ ,  $T_A = T_{MIN}$  to  $T_{MAX}$ , unless otherwise noted.)

PARAMETER	SYMBOL	CONDITIONS	MIN	TYP	MAX	UNITS
Chip-Enable to Write Setup	$t_{CE}$		0			ns
Write Pulse Width High	$t_{WH}$		80			ns
Write Pulse Width Low	$t_{WL}$		80			ns
Data Setup	$t_{DS}$	Parallel mode		240		ns
		32-bit serial mode		160		
Data Hold	$t_{DH}$		0			ns
Latch Pulse Width	$t_L$		80			ns
Latch Delay	$t_D$		80			ns
Switch Break-Before-Make Delay	$t_{ON - t_{OFF}}$			15		ns
LATCH Edge to Switch Off	$t_{OFF}$	LATCH on		35		ns
LATCH Edge to Switch On	$t_{ON}$			50		ns

**Note 1:** Guaranteed by design.

**Note 2:** See *Dynamic Test Circuits* on page 11.

**Note 3:** 3dB typical crosstalk improvement when  $R_S = 0\Omega$ .

**Note 4:** Input test signal: 3.58MHz sine wave of amplitude 40IRE superimposed on a linear ramp (0 to 100IRE). IRE is a unit of video-signal amplitude developed by the International Radio Engineers. 140IRE = 1.0V.

**MAXIM**

3

■ 5876651 0010712 6T2 ■

# 8 x 8 Video Crosspoint Switch

## Pin Description

PIN		NAME	FUNCTION
DIP	PLCC		
—	1, 12, 23, 34	N.C.	No connect. Not internally connected.
1	2	D1/SER OUT	Parallel Data Bit D1 when SER/PAR = 0V. Serial Output for cascading multiple parts when SER/PAR = 5V.
2	3	D0/SER IN	Parallel Data Bit D0 when SER/PAR = 0V. A Serial Input when SER/PAR = 5V.
3, 4, 6	4, 5, 7	A2, A1, A0	Output Buffer Address Lines
5, 7, 9, 11, 13, 15, 17, 19	6, 8, 10, 13, 15, 17, 19, 21	IN0-IN7	Video Input Lines
8	9	LOAD	Asynchronous control line. When LOAD = 1, all the 400Ω internal active loads are on. When LOAD = 0, external 400Ω loads must be used. The buffers MUST have a resistive load to maintain stability.
10, 12	11, 14	DGND	Digital Ground Pins. Both DGND pins must have the same potential and be bypassed to AGND. DGND should be within ±0.3V of AGND.
14	16	EDGE/LEVEL	When this control line is high, the 2nd-rank registers are loaded with the rising edge of the LATCH line. If this control line is low, the 2nd-rank registers are transparent when LATCH is low, passing data directly from the 1st-rank registers to the decoders.
16, 26, 40	18, 29, 44	V+	All V+ pins must be tied to each other and bypassed to AGND separately (Figure 2).
18	20	SER/PAR	5V = 32-Bit Serial, 0V = 7-Bit Parallel
20, 34	22, 38	V-	Both V- pins must be tied to each other and bypassed to AGND separately (Figure 2).
21	24	WR	WRITE in the serial mode, shifts data in. In the parallel mode, WR loads data into the 1st-rank registers. Data is latched on the rising edge.
22	25	LATCH	If EDGE/LEVEL = 5V, data is loaded from the 1st-rank registers to the 2nd-rank registers on the rising edge of LATCH. If EDGE/LEVEL = 0V, data is loaded while LATCH = 0V. In addition, data is loaded during the execution of parallel-mode functions 1011 through 1110, or if LATCH = 5V during the execution of the parallel-mode "software-LATCH" command (1111).
23	26	CE	Chip Enable. When CE = 0V and CE = 5V, the WR line is enabled.
24	27	CE	Chip Enable. When CE = 0V and CE = 5V, the WR line is enabled.
25, 27, 29, 31, 33, 35, 37, 39	28, 30, 32, 35, 37, 39, 41, 43	OUT7-OUT0	Output Buffers 7-0 (Note 1)
28, 30, 32	31, 33, 36	AGND	Analog Ground must be at 0.0V since the gain resistors of the buffers are tied to these 3 pins.
36	40	D3	Parallel Data Bit D3 when SER/PAR = 0V. When D3 = 0V, D0-D2 specifies the input channel to be connected to buffer. When D3 = 5V, then D0-D2 specify control codes. D3 is not used when SER/PAR = 5V.
38	42	D2	Parallel Data Bit D2 when SER/PAR = 0V. Not used when SER/PAR = 5V.

**Note 1:** Buffer inputs are internally grounded with a 1000 or 1001 command from the D3-D0 lines. AGND must be at 0.0V since the gain setting resistors of the buffers are internally tied to AGND.

# 8 x 8 Video Crosspoint Switch

MAX456

## Detailed Description

### Output Buffers

The MAX456 video crosspoint switch consists of 64 T-switches in an 8 x 8 grid (Figure 1). The 8 matrix outputs are followed by 8 wideband buffers optimized for driving 400 $\Omega$  and 20pF loads. Each buffer has an internal active load on the output that can be readily shut off via the LOAD input (off when LOAD = 0V). The shut-off is useful when two or more MAX456 circuits are connected in parallel to create more input channels. With more input channels, only one set of buffers can be active and only one set of loads can be driven. And, when active, the buffer must have either 1) an internal load, 2) the internal load of another buffer in another MAX456, or 3) an external load.

Each MAX456 output can be disabled under logic control. When a buffer is disabled, its output enters a high-impedance state. In multichip parallel applications, the disable function prevents inactive outputs from loading lines driven by other devices. Disabling the inactive buffers reduces power consumption.

The MAX456 outputs connect easily to MAX470 quad, gain-of-two buffers when 75 $\Omega$  loads must be driven.

### Power-On RESET

The MAX456 has an internal power-on reset (POR) circuit that remains low for 5 $\mu$ s when power is applied. POR also remains low if the total supply voltage is less than 4V. **The POR disables all buffer outputs at power-up**, but the switch matrix is not preset to any initial condition. The desired switch state should be programmed before the buffer outputs are enabled.

## Digital Interface

The desired switch state can be loaded in a 7-bit parallel-interface mode or 32-bit serial-interface mode (see Table 3 and Figures 4-6). All action associated with the WR line occurs on its rising edge. The same is true for the LATCH line if EDGE/LEVEL is high. Otherwise, the second-rank registers update while LATCH is low (when EDGE/LEVEL is low). WR is logically ANDed with CE and  $\overline{\text{CE}}$  to allow active-high or active-low chip enable.

### 7-Bit Parallel Mode

In the parallel-interface mode, the 7 data bits A2-A0 and D3-D0 specify an output channel (A2-A0) and the input channel to which it connects (D3-D0). The data is loaded on the rising edge of WR. The 8 input channels are selected by 0000 through 0111 (D3-D0). The remaining 8 codes (1000-1111) control other MAX456 functions, as listed in Table 1.

### 32-Bit Serial-Interface Mode

In serial mode (SER/PAR = high), all first-rank registers are loaded with data, making it unnecessary to specify an output address (A2, A1, A0). The input data format is D3-D0, starting with OUT0 and ending with OUT7 for 32 total bits. Only codes 0000 through 1010 are valid. Code 1010 disables a buffer, while code 1001 enables it. After data is shifted into the 32-bit first-rank register, it is transferred to the second rank by the LATCH line (see Table 2).

MAXIM

5

■ 5876651 0010714 475 ■

## 8 x 8 Video Crosspoint Switch

**Table 1. Parallel-Interface Mode Functions**

A2-A0	D3-D0	FUNCTION
Selects Output Buffer, OUT0 to OUT7	0000 to 0111	Connect the buffer selected by A2-A0 to the input channel selected by D3-D0.
	1000	Connect the buffer selected by A2-A0 to DGND. Note, if the buffer output is on, its output is its offset voltage.
	1011	Shut off the buffer selected by A2-A0, and retain 2nd-rank contents.
	1100	Turn on the buffer selected by A2-A0, or restore the previously connected channel.
	1101	Turn off all buffers, or leave 2nd-rank registers unchanged.
	1110	Turn on all buffers, or restore the previously connected channels.
	1111	Send a pulse to the 2nd-rank registers to load them with the contents of the 1st-rank registers. When latch is held high, this "software-LATCH" command performs the same function as pulsing LATCH low.
	1001 and 1010	Do not use these codes in the parallel-interface mode. These codes are for the serial-interface mode only.

**Table 2. Serial-Interface Mode Functions**

D3-D0	FUNCTION
0000 to 0111	Connect the selected buffer to the input channel selected by D3-D0.
1000	Connect the input of the selected buffer to GND. Note, if the buffer output remains on, its input is its offset voltage.
1001	Turn on the selected buffer and connect its input to GND. Use this code to turn on buffers after power is applied. The default power-up state is all buffers disabled.
1010	Shut off the selected buffer at the specified channel, and erase data stored in the 2nd rank of registers. The 2nd rank now holds the command word 1010.
1011 to 1111	Do not use these codes in the serial-interface mode. They inhibit the latching of the 2nd-rank registers, which prevents proper data loading.

# 8 x 8 Video Crosspoint Switch

**MAX456**

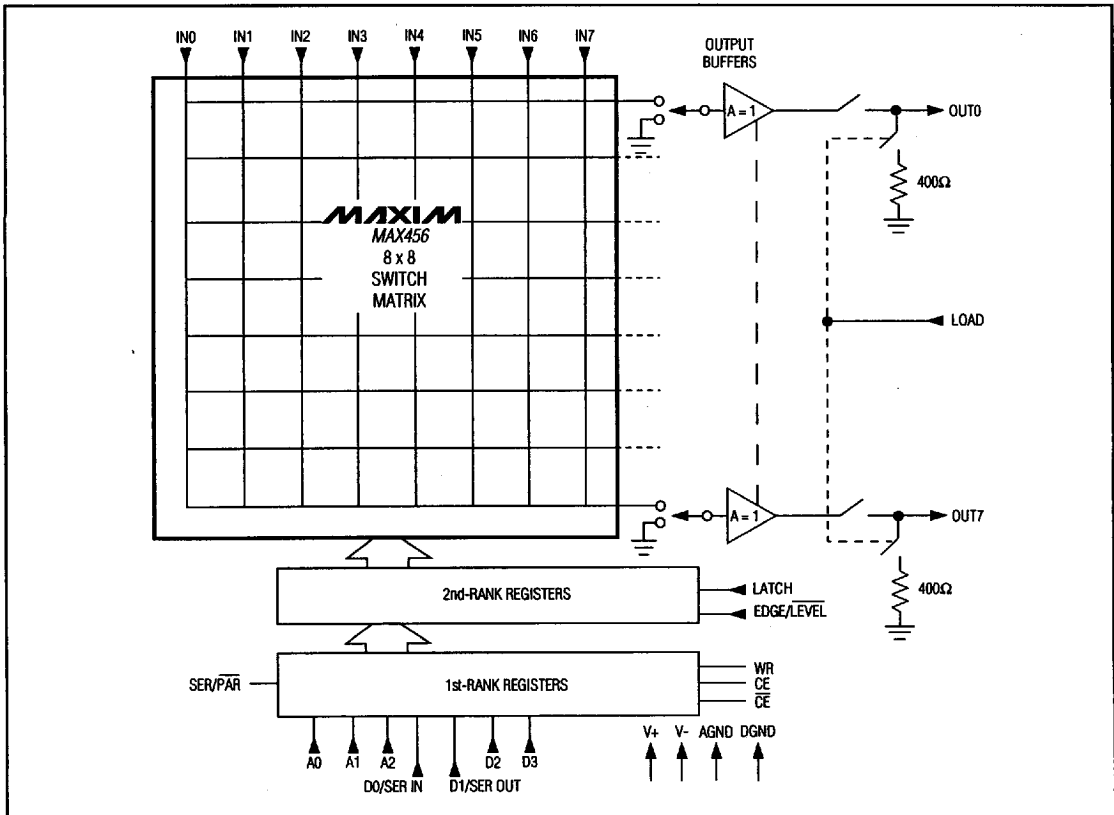

Figure 1. MAX456 Functional Diagram

Table 3. Input/Output Line Configurations

SERIAL/ PARALLEL	D3	D2	D1	D0	A2-A0	COMMENT
H	X	X	Serial Output	Serial Input	X	32-Bit Serial Mode
L	H	Parallel Input	Parallel Input	Parallel Input	Output Buffer Address	Parallel Mode, D0-D2 = Control Code
L	L	Parallel Input	Parallel Input	Parallel Input	Output Buffer Address	Parallel Mode, D0-D2 = Input Address

Note : X = Don't Care, H = 5V, L = 0V

**MAXIM**

7

■ 5876651 0010716 248 ■

# 8 x 8 Video Crosspoint Switch

## Typical Application

Figure 2 shows a typical application of the MAX456 with MAX470 quad, gain-of-two buffers at the outputs to drive 75Ω loads. This application shows the MAX456 digital-switch control interface set up in the 7-bit parallel mode. The MAX456 uses 7 data lines and 2 control lines (WR and LATCH). Two additional lines may be needed to control CE and LOAD when using multiple MAX456s.

The input/output information is presented to the chip at A2-A0 and D3-D0 by a parallel printer port. The data is stored in the 1st-rank registers on the rising edge of WR. When the LATCH line goes high, the switch configuration is loaded into the 2nd-rank registers, and all 8 outputs enter the new configuration at the same time.

Each 7-bit word updates only one output buffer at a time. If several buffers are to be updated, the data is individually loaded into the 1st-rank registers. Then, a single LATCH pulse is used to reconfigure all channels simultaneously.

The short Basic program in Figure 3 loads programming data into the MAX456 from any IBM PC or compatible. It uses the computer's "LPT1" output to interface to the circuit, then automatically finds the address for LPT1 and displays a table of valid input values to be used. The program does not keep track of previous commands, but it does display the last data sent to LPT1, which is written and latched with each transmission.

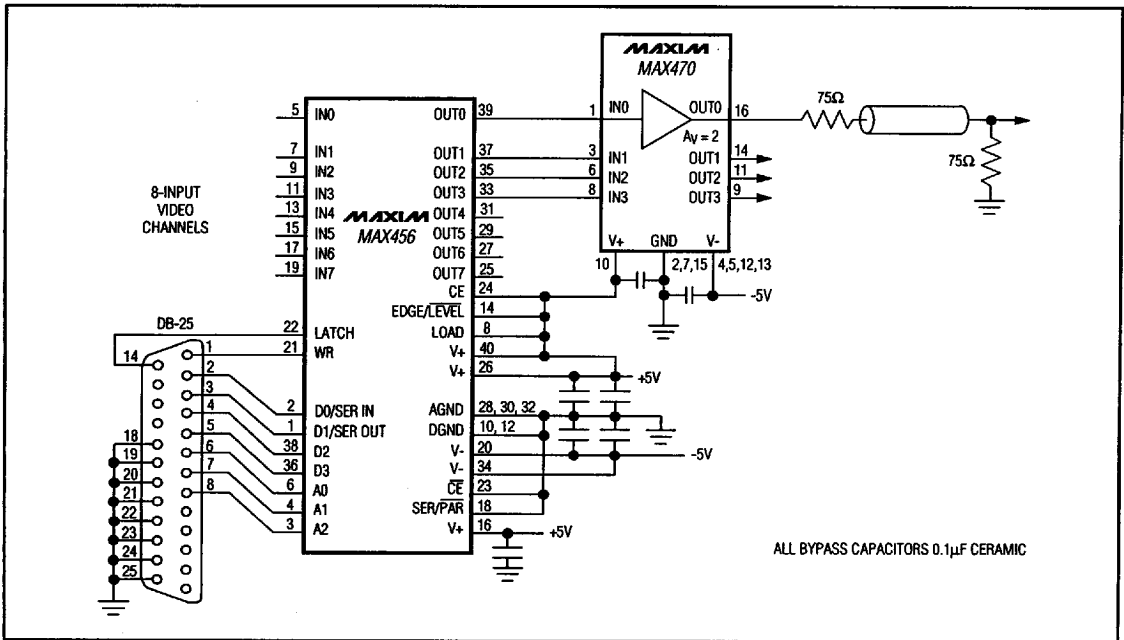

Figure 2. Typical Application Circuit

# 8 x 8 Video Crosspoint Switch

MAX456

```

10 REM MAX456at rev. 4/26/90 : CLS
20 DIM VALU(5,5): COL=17 : RO=5
30 DEF SEG=&MO : ADDRESS=(PEEK(&M409)*256)+(PEEK(&M408))
40 LOCATE RO-4,COL-2 : PRINT"MAX456 8 X 8 CROSSPOINT SWITCH "
50 LOCATE RO+8,COL-12 : PRINT " Input and control codes:"
60 LOCATE RO+10,COL-16 : PRINT "0 to 7 = Valid channel and buffer input values"
70 LOCATE RO+11,COL-12 : PRINT " 8 = Specify Buffer input to connect to ground"
80 LOCATE RO+12,COL-12 : PRINT "11 = Shut off specified Buffer output"
90 LOCATE RO+13,COL-12 : PRINT "12 = Turn on specified Buffer output"
100 LOCATE RO+14,COL-12 : PRINT "13 = Shut off all Buffer outputs"
110 LOCATE RO+15,COL-12 : PRINT "14 = Turn on all Buffer outputs"
120 LOCATE RO+16,COL-12 : PRINT " E = End Program"
130 LOCATE RO+0,COL+21 : PRINT " "
140 LOCATE RO-1,COL+5 : PRINT "Input Channel or "
150 LOCATE RO+0,COL+5 : INPUT "Control Code ? ",CH$: REM D0-D3
160 CH=VAL(RIGHT$(CH$,2)) : IF CH<0 OR CH>15 OR CH=9 OR CH=10 THEN 130
170 IF RIGHT$(CH$,1)="#" OR RIGHT$(CH$,1)="e" THEN END
180 LOCATE RO+1,COL+5 : INPUT "Buffer Output ? ",AM$: REM A0-A2
190 LOCATE RO+1,COL+21 : PRINT " "
200 AM=VAL(RIGHT$(AM$,1)) : IF AM<0 OR AM>7 THEN 180
210 LOCATE RO+3,COL+5 : PRINT "OUTPUT VALUES"
220 LOCATE RO+4,COL+5 : PRINT "DATA=";CH :LOCATE RO+4,COL+15 :PRINT" BUF=";AM
230 OUT ADDRESS,(AM*16)+CH: REM DATA OUT
240 OUT ADDRESS+2,1 : REM Write low DB25-1
250 OUT ADDRESS+2,2 : REM Latch low DB25-14 and WR hi DB25-1
260 OUT ADDRESS+2,0 : REM take Latch hi
270 GOTO 130
    
```

Figure 3. BASIC Program for Loading Data into the MAX456 from a PC Using Figure 2's Circuit

## Timing Diagrams

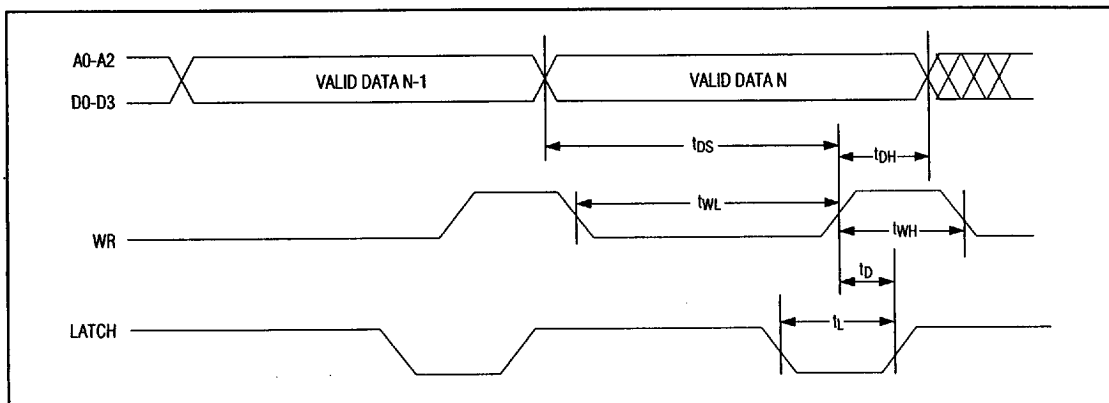

Figure 4. Write Timing for Serial- and Parallel-Interface Modes

MAXIM

9

■ 5876651 0010718 010 ■

# 8 x 8 Video Crosspoint Switch

## Timing Diagrams (continued)

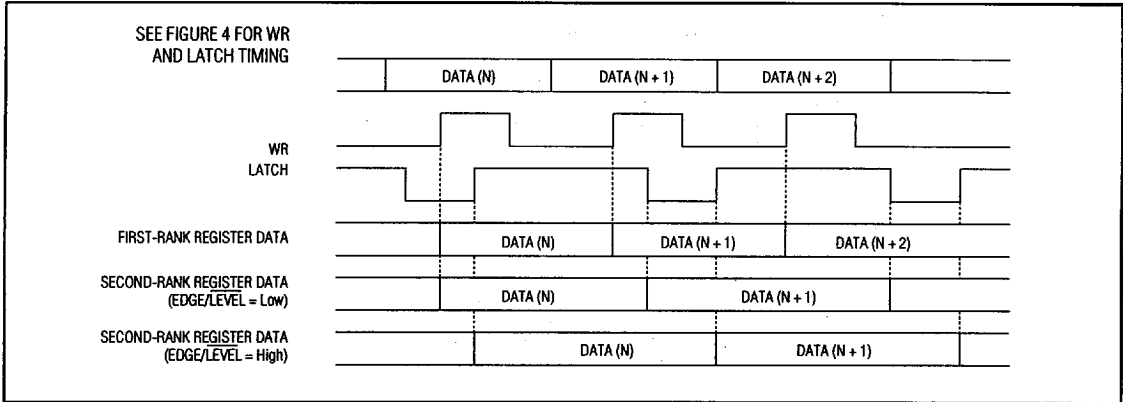

Figure 5. Parallel-Interface Mode Format (SER/PAR = Low)

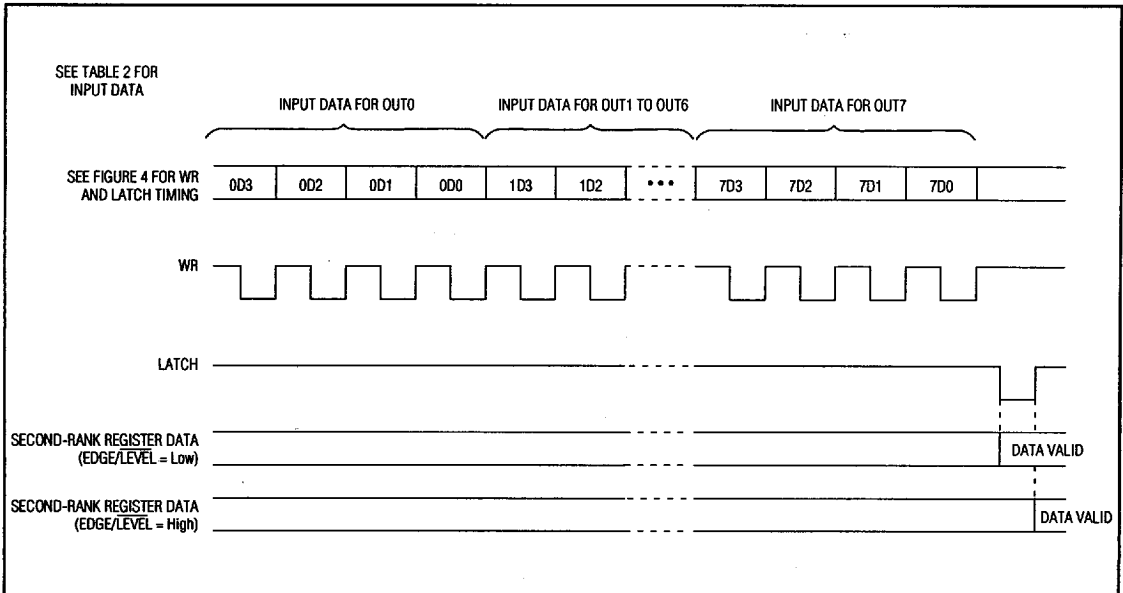
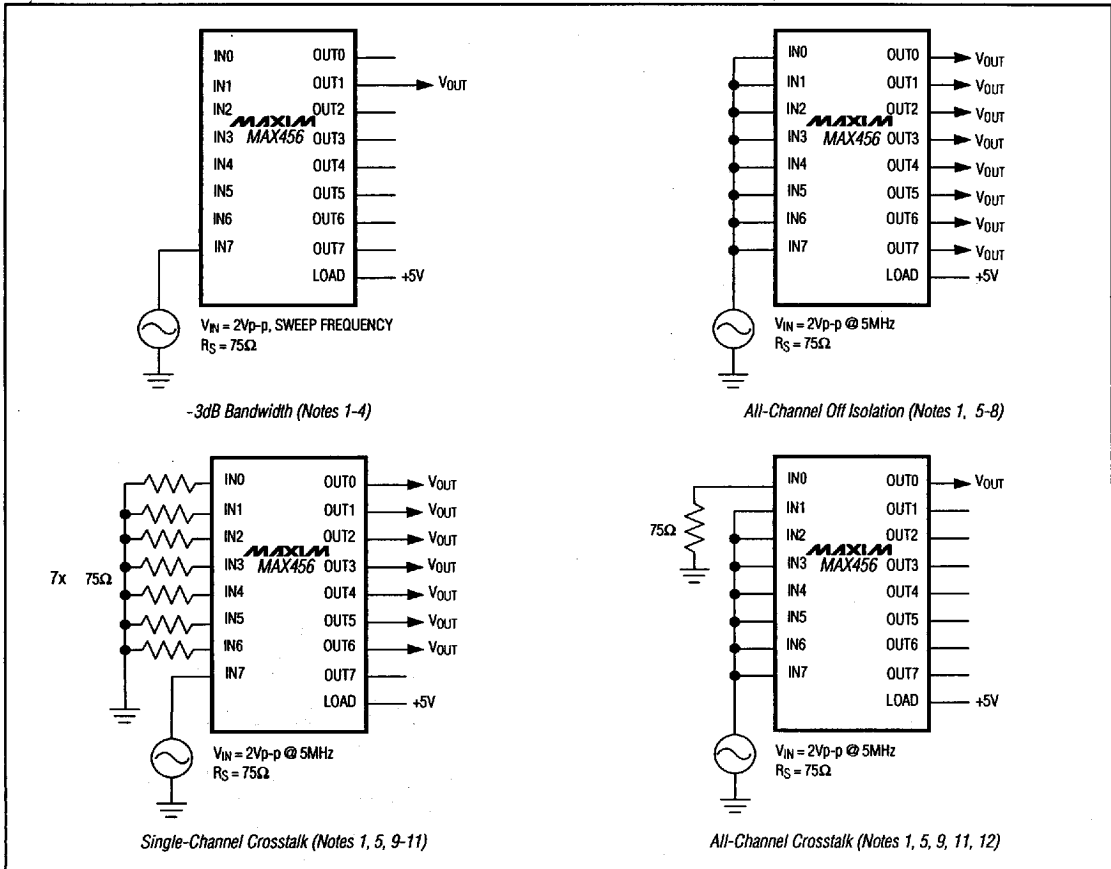

Figure 6. 32-Bit Serial-Mode Interface Format (SER/PAR = High)

# 8 x 8 Video Crosspoint Switch

## Dynamic Test Circuits

MAX456



- Note 1:** Connect LOAD (pin 8) to +5V (internal 400Ω loads on at all outputs).
- Note 2:** Program any one input to connect to any one output (see Table 1 or 2 for programming codes).
- Note 3:** Turn on buffer at the selected output (see Table 1 or 2).
- Note 4:** Drive the selected input with  $V_{IN}$  and measure  $V_{OUT}$  at the selected output.
- Note 5:** Program each numbered input to connect to the same numbered output (IN0 to OUT0, IN1 to OUT1, etc.). See Table 1 or 2 for programming codes.
- Note 6:** Turn off all output buffers (see Table 1 or 2).
- Note 7:** Drive all inputs with  $V_{IN}$  and measure  $V_{OUT}$  at any output.
- Note 8:** Isolation (in dB) =  $20\log_{10}(V_{OUT}/V_{IN})$ .
- Note 9:** Turn on all output buffers (see Table 1 or 2).
- Note 10:** Drive any one input with  $V_{IN}$  and measure  $V_{OUT}$  at any undriven output.
- Note 11:** Crosstalk (in dB) =  $20\log_{10}(V_{OUT}/V_{IN})$ .
- Note 12:** Drive all but one input with  $V_{IN}$  and measure  $V_{OUT}$  at the undriven output.

**MAXIM**

11

■ 5876651 0010720 779 ■

# 8 x 8 Video Crosspoint Switch

## Pin Configurations (continued)

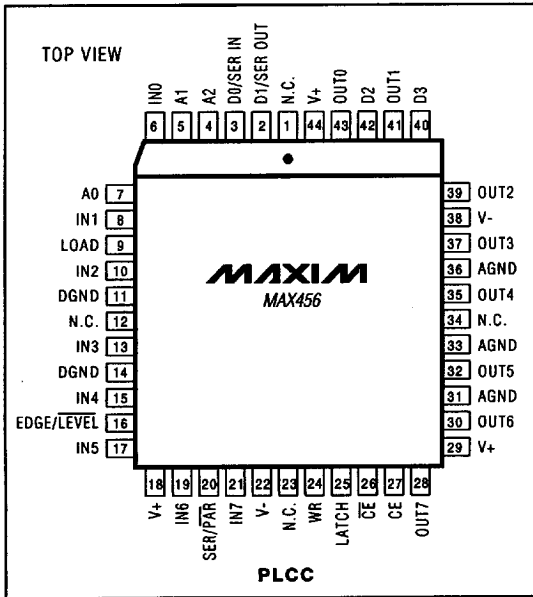

## Ordering Information (continued)

PART	TEMP. RANGE	PIN-PACKAGE
MAX456EPL	-40°C to +85°C	40 Plastic DIP
MAX456EQH	-40°C to +85°C	44 PLCC
MAX456EJL	-40°C to +85°C	40 CERDIP

## Chip Topography

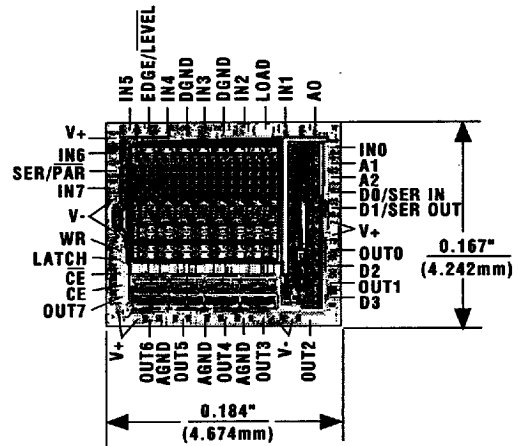

TRANSISTOR COUNT: 3820;  
SUBSTRATE CONNECTED TO V+.

Maxim cannot assume responsibility for use of any circuitry other than circuitry entirely embodied in a Maxim product. No circuit patent licenses are implied. Maxim reserves the right to change the circuitry and specifications without notice at any time.

12 **Maxim Integrated Products, 120 San Gabriel Drive, Sunnyvale, CA 94086 (408) 737-7600**

© 1994 Maxim Integrated Products Printed USA **MAXIM** is a registered trademark of Maxim Integrated Products.

■ 5876651 0010721 605 ■

46995