

ASSP

Serial Input PLL Frequency Synthesizer

MB1511

■ DESCRIPTION

The Fujitsu MB1511 is a single chip serial input PLL frequency synthesizer designed for VHF tuner and cellular telephone applications.

It contains a 1.1 GHz dual modulus prescaler which enables pulse swallow function, and an analog switch to speed up lock up time.

It operates supply voltage of 3.0 V typ. and dissipates 7 mA typ. of current realized through the use of Fujitsu's unique U-ESBIC Bi-CMOS technology.

The MB1511 is housed in SSOP package, this enables high integration.

■ FEATURES

- Low power supply voltage: $V_{CC} = 2.7$ to 5.5 V
- High operating frequency: $f_{IN\ MAX} = 1.1$ GHz ($V_{IN\ MIN} = -10$ dBm)
- Pulse swallow function: 64/65 or 128/129
- Low supply current: $I_{CC} = 7$ mA typ.
 - Serial input 18-bit programmable divider consisting of:
 - Binary 7-bit swallow counter: 0 to 127
 - Binary 11-bit programmable counter: 16 to 2047
- Serial input 15-bit programmable reference divider consisting of:
 - Binary 14-bit programmable reference counter: 8 to 16383
 - 1-bit switch counter (SW) sets divide ratio of prescaler

(Continued)

■ PACKAGE

20 pin, Plastic SSOP

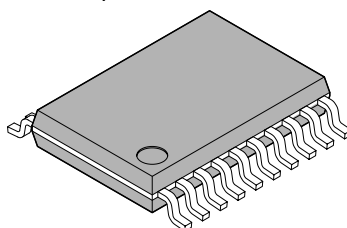

(FPT-20P-M03)

MB1511

(Continued)

- On-chip analog switch achieves fast lock up time
- 2 types of phase detector output
 - On-chip charge pump (Bipolar type)
 - Output for external charge pump
- Wide operating temperature: -40°C to $+85^{\circ}\text{C}$
- 20-pin Plastic Shrink Small Outline Package (Suffix: -PFV)

■ PIN ASSIGNMENT

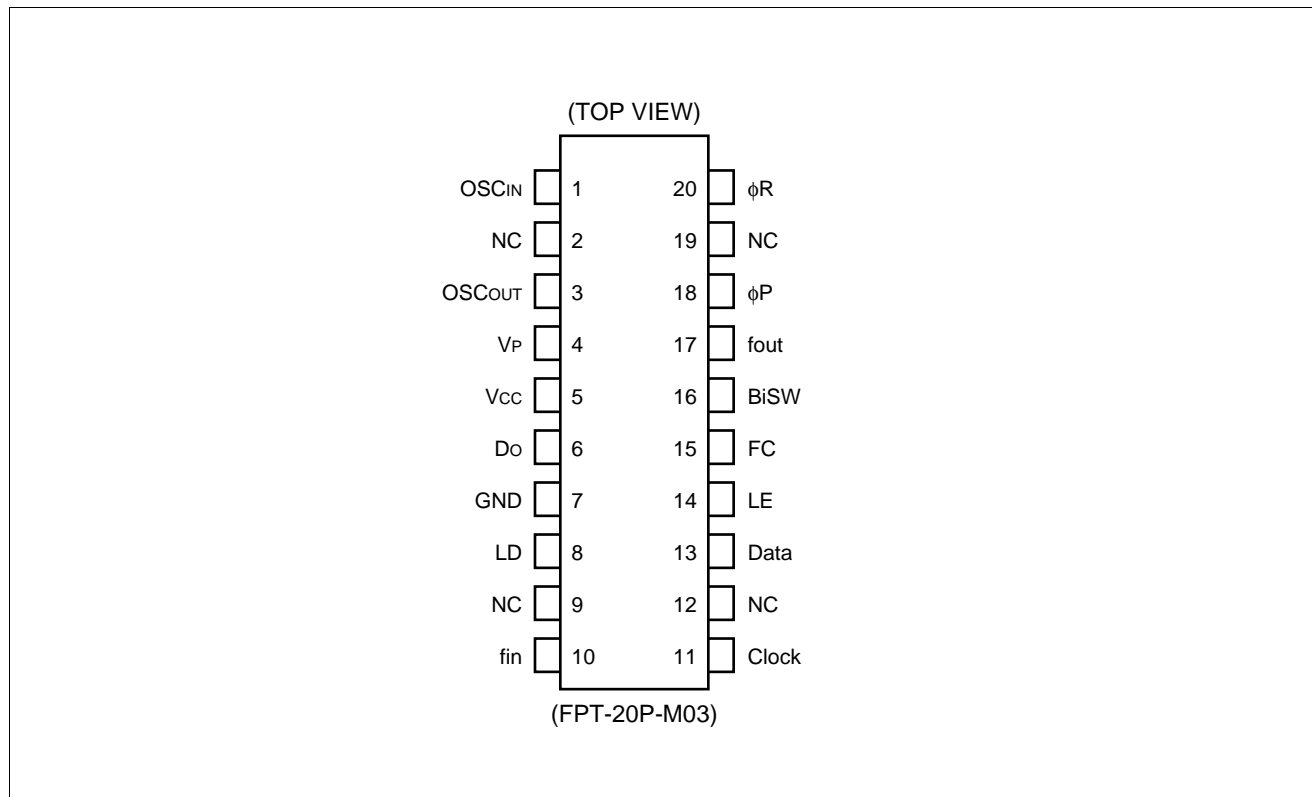

■ PIN DESCRIPTION

Pin No.	Pin Name	I/O	Functions
1	OSC _{IN}	I	Oscillator input.
3	OSC _{OUT}	O	Oscillator output. A crystal is placed between OSC _{IN} and OSC _{OUT} .
4	V _P	—	Power supply input for charge pump and analog switch.
5	V _{CC}	—	Power supply voltage input.
6	D _O	O	Charge pump output. The characteristics of charge pump is reversed depending upon FC input.
7	GND	—	Ground.
8	LD	O	Phase comparator output. Normally this pin outputs high level. While the phase difference of fr and fp exists, this pin outputs low level.
10	fin	I	Prescaler input. The connection with an external VCO should be AC connection.
11	Clock	I	Clock input for 19-bit shift register and 16-bit shift register. On rising edge of the clock shifts one bit of data into the shift registers.
13	Data	I	Binary serial data input. The last bit of the data is a control bit which specified destination of shift registers. When this bit is high level and LE is high level, the data stored in shift register is transferred to 15-bit latch. When this bit is low level and LE is high level, the data is transferred to 18-bit latch.
14	LE	I	Load enable input (with internal pull up resistor). When LE is high or open, the data stored in shift register is transferred into latch depending upon the control bit. At the time, internal charge pump output is connected to BiSW pin because internal analog switch becomes ON state.
15	FC	I	Phase select input of phase comparator (with internal pull up resistor). When FC is low level, the characteristics of charge pump, phase comparator is reversed. FC input signal controls fout pin (test pin) output level, fr or fp.
16	BiSW	O	Analog switch output. Usually BiSW pin is set high-impedance state. When internal analog switch is ON (LE pin is high level), this pin outputs internal charge pump output.
17	fout	O	Monitor pin of phase comparator input. fout pin outputs either programmable reference divider output (fr) or programmable divider output (fp) depending upon FC pin input level. FC = H: It is the same as fr output level. FC = L: It is the same as fp output level.
18	φP	O	Output for external charge pump.
20	φR	O	The characteristics are reversed according to FC input. φP pin is N-channel open drain output.
2, 9 12, 19	NC	—	No connection.

■ BLOCK DIAGRAM

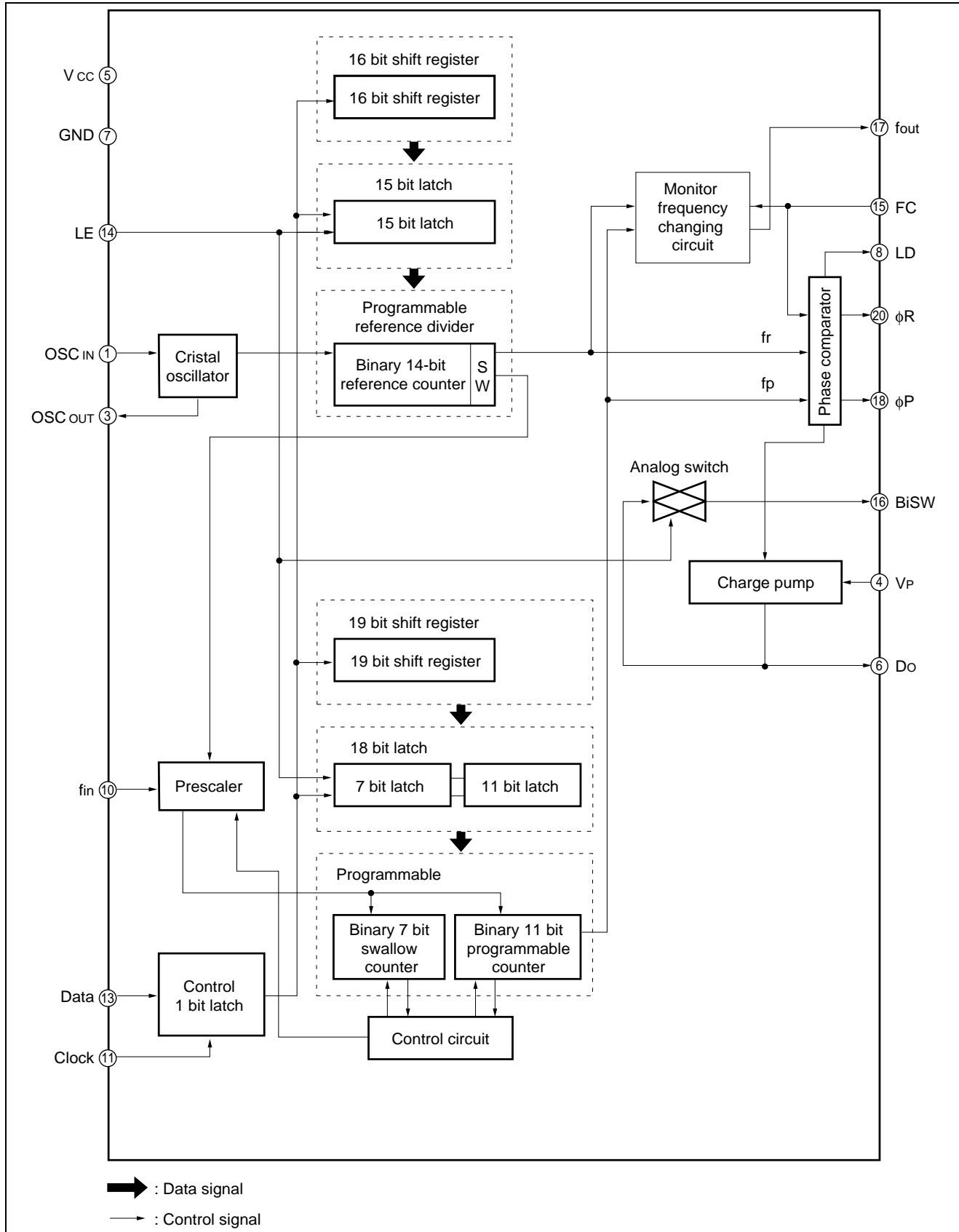

■ FUNCTIONAL DESCRIPTIONS

1. Pulse Swallow Function

The divide ratio is set using the following equation.

$$f_{vco} = [(M \times N) + A] \times f_{osc} \div R$$

f_{vco} : Output frequency of external voltage controlled oscillator (VCO)

M : Preset modulus of external dual modulus prescaler (64 or 128)

N : Preset divide ratio of binary 11-bit programmable counter (16 to 2047)

A : Preset divide ratio of binary 7-bit swallow counter ($0 \leq A \leq 127$, $A < N$)

f_{osc} : Output frequency of the external reference frequency oscillator

R : Preset divide ratio of binary 14-bit programmable reference counter (8 to 16383)

2. Serial Data Input

Serial data input is achieved by three inputs, such as Data pin, Clock pin and LE pin. Serial data input controls 15-bit programmable reference divider and 18-bit programmable divider, respectively.

Binary serial data is input to Data pin.

On rising edge of clock shifts one bit of serial data into the internal shift registers and when load enable pin is high level or open, stored data is transferred into latch depending upon the control bit.

Control data "H" data is transferred into 15-bit latch.

Control data "L" data is transferred into 18-bit latch.

(1) Programmable Reference Divider

Programmable reference divider consists of 16-bit shift register, 15-bit latch and 14-bit reference counter. Serial 16-bit data format is shown below.

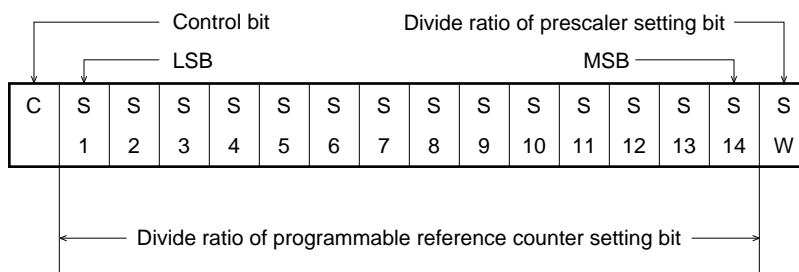

• 14-BIT PROGRAMMABLE REFERENCE COUNTER DIVIDE RATIO

Divide Ratio	S14	S13	S12	S11	S10	S9	S8	S7	S6	S5	S4	S3	S2	S1
8	0	0	0	0	0	0	0	0	0	0	1	0	0	0
9	0	0	0	0	0	0	0	0	0	0	1	0	0	1
⋮	⋮	⋮	⋮	⋮	⋮	⋮	⋮	⋮	⋮	⋮	⋮	⋮	⋮	⋮
16383	1	1	1	1	1	1	1	1	1	1	1	1	1	1

NOTES: Divide ratio less than 8 is prohibited.

Divide ratio: 8 to 16383

SW: This bit selects divide ratio of prescaler.

SW = H: 64/65

SW = L: 128/129

S1 to S14: These bits select divide ratio of programmable reference divider.

C: Control bit (sets as high level).

Data is input from MSB side.

(2) Programmable Divider

Programmable divider consists of 19-bit shift register, 18-bit latch, 7-bit swallow counter and 11-bit programmable counter. Serial 19-bit data format is shown following page.

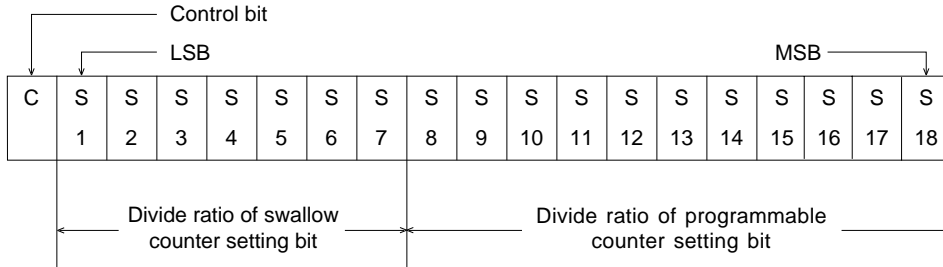

• 7-bit Swallow Counter Divide Ratio

Divide Ratio	S 7	S 6	S 5	S 4	S 3	S 2	S 1
A							
0	0	0	0	0	0	0	0
1	0	0	0	0	0	0	1
⋮	⋮	⋮	⋮	⋮	⋮	⋮	⋮
127	1	1	1	1	1	1	1

Note: Divide ratio: 0 to 127

• 11-bit Programmable Counter Divide Ratio

Divide Ratio	S 18	S 17	S 16	S 15	S 14	S 13	S 12	S 11	S 10	S 9	S 8
N											
16	0	0	0	0	0	0	1	0	0	0	1
17	0	0	0	0	0	0	1	0	0	0	1
⋮	⋮	⋮	⋮	⋮	⋮	⋮	⋮	⋮	⋮	⋮	⋮
2047	1	1	1	1	1	1	1	1	1	1	1

Notes: Divide ratio less than 16 is prohibited.
 Divide ratio: 16 to 2047
 S1 to S7: Swallow counter divide ratio setting bit. (0 to 127)
 S8 to S18: Programmable counter divide ratio setting bit. (16 to 2047)
 C: Control bit (sets as low level).
 Data is input from MSB side.

3. Serial Data Input Timing

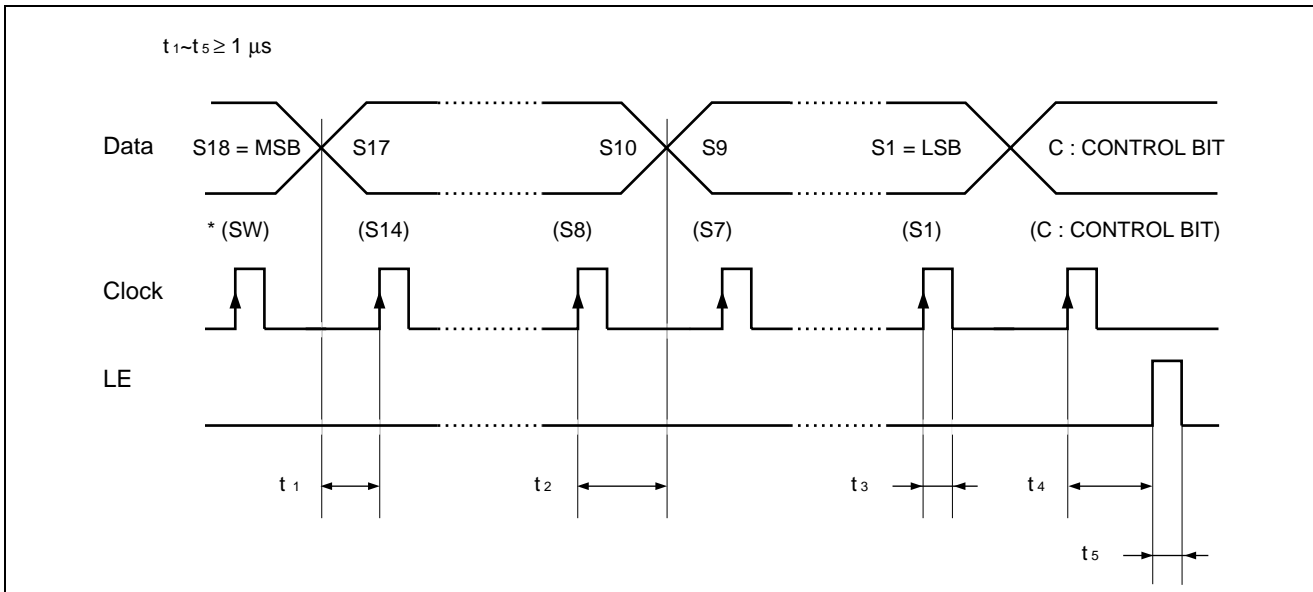

* : Parenthesis data is used for setting divide ratio of programmable reference divider.
 On rising edge of clock shifts one bit of data in the shift register.

4. Phase Characteristics

FC pin is provided to change phase characteristics of phase comparator. Characteristics of internal charge pump output level (D_o), phase comparator output level (ϕ_R , ϕ_P) are reversed depending upon FC pin input level. Also, monitor pin (f_{OUT}) output level of phase comparator is controlled by FC pin input level. The relation between outputs (D_o , ϕ_R , ϕ_P) and FC input level are shown below.

	FC : "H" or open				FC : "L"			
	D_o	ϕ_R	ϕ_P	f_{out}	D_o	ϕ_R	ϕ_P	f_{out}
$f_r > f_p$	H	L	L	(fr)	L	H	Z	(fp)
$f_r = f_p$	Z	L	Z	(fr)	Z	L	Z	(fp)
$f_r < f_p$	L	H	Z	(fr)	H	L	L	(fp)

Note: Z = (High impedance)

Depending upon VCO characteristics, FC pin should be set accordingly:

- When VCO characteristics are like (1), FC should be set High or open circuit; When VCO characteristics are like (2), FC should be set Low.

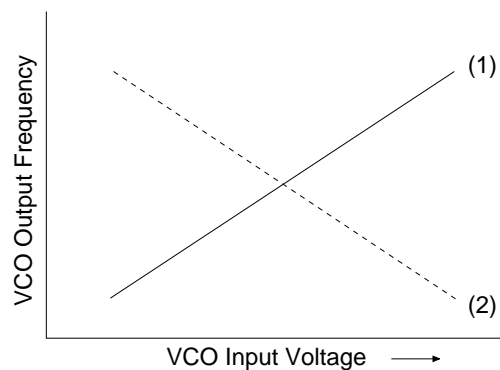

Phase comparator output waveforms are shown below.

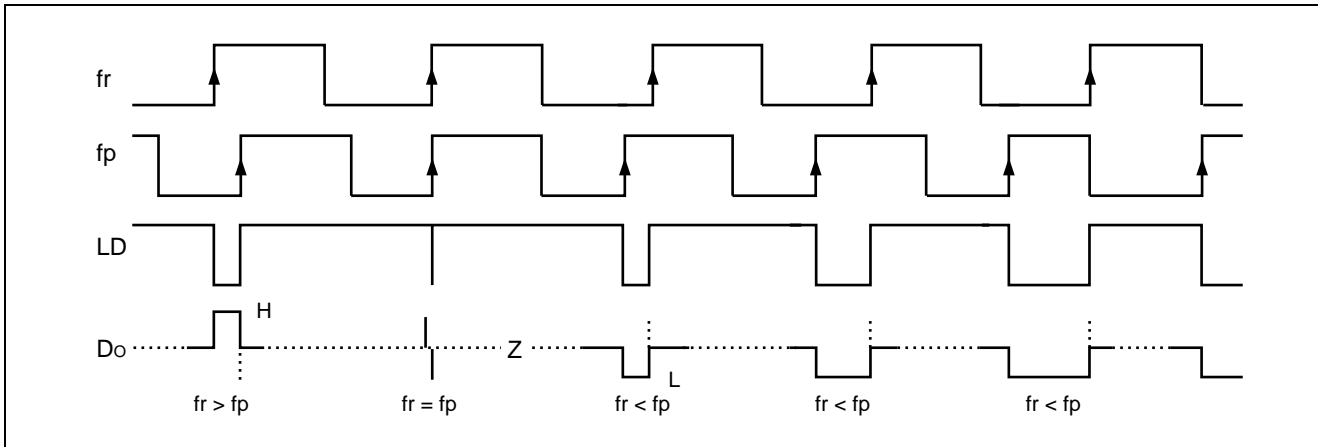

Notes: Phase difference detection range: -2π to $+2\pi$

Spike appearance depends on charge pump characteristics. Also, the spike is output in order to diminish dead band. When $f_r > f_p$ or $f_r < f_p$, spike might not appear depending upon charge rump characteristics.

5. Analog Switch

ON/OFF of analog switch is controlled by LE input signal. When the analog switch is ON, internal charge pump output (D_o) is connected to BiSW pin. When the analog switch is OFF, BiSW pin is set to high-impedance state.

LE	Analog Switch
H (Changing the divide ratio of internal prescaler)	ON
L (Normal operation mode)	OFF

When an analog switch is inserted between LP1 and LP2, faster lock up times is achieved to reduce LPF time constant during PLL channel switching.

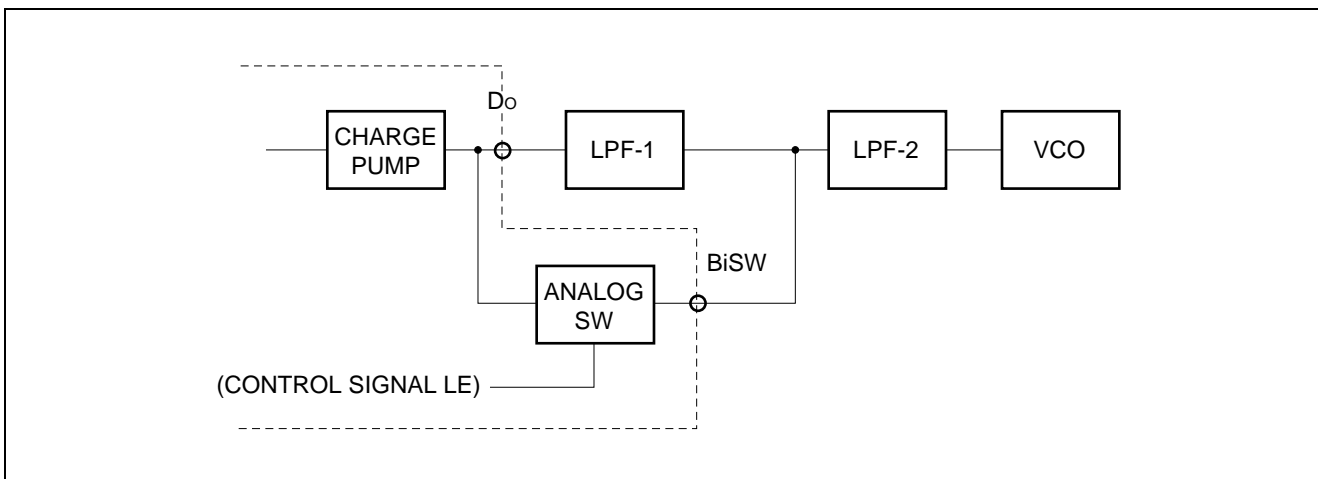

■ ABSOLUTE MAXIMUM RATINGS (See WARNING)

Parameter	Symbol	Rating		Unit
		Min.	Max.	
Power supply voltage	V_{CC}	-0.5	+7.0	V
	V_P	V_{CC}	+10.0	V
Output voltage	V_{OUT}	-0.5	$V_{CC} + 0.5$	V
Open-drain voltage	V_{OOP}	-0.5	+8.0	V
Output current	I_{OUT}	-10	+10	mA
Storage temperature	T_{stg}	-55	+125	°C

WARNING: Semiconductor devices can be permanently damaged by application of stress (voltage, current, temperature, etc.) in excess of absolute maximum ratings. Do not exceed these ratings.

■ RECOMMENDED OPERATING CONDITIONS

Parameter	Symbol	Value			Unit
		Min.	Typ.	Max.	
Power supply voltage	V_{CC}	2.7	3.0	5.5	V
	V_P	V_{CC}	—	8.0	V
Input voltage	V_{IN}	GND	—	V_{CC}	V
Operating temperature	T_a	-40	—	+85	°C

WARNING: The recommended operating conditions are required in order to ensure the normal operation of the semiconductor device. All of the device's electrical characteristics are warranted when the device is operated within these ranges.

Always use semiconductor devices within their recommended operating condition ranges. Operation outside these ranges may adversely affect reliability and could result in device failure.

No warranty is made with respect to uses, operating conditions, or combinations not represented on the data sheet. Users considering application outside the listed conditions are advised to contact their FUJITSU representatives beforehand.

HANDLING PRECAUTIONS

- This device should be transported and stored in anti-static containers.
- This is static-sensitive device; take proper anti-ESD precautions. Ensure that personnel and equipment are properly grounded. Cover workbenches with grounded conductive mats.
- Always turn the power supply off before inserting or removing the device from its socket.
- Protect leads with a conductive sheet when handling or transporting PC boards with devices.

MB1511

■ ELECTRICAL CHARACTERISTICS

($V_{CC} = 2.7\text{ V to }5.5\text{ V}$, $T_a = -40^\circ\text{C to }+85^\circ\text{C}$)

Parameter		Symbol	Values			Unit
			Min.	Typ.	Max.	
Power supply current*1		I_{CC}	—	7.0	—	mA
Operating frequency	f_{IN}^{*2}	f_{IN}	10	—	1100	MHz
	OSC_{IN}	f_{OSC}	—	12	20	MHz
Input sensitivity	$fin-1^{*3}$	V_{fin1}	-4	—	6	dBm
	$fin-2^{*4}$	V_{fin2}	-10	—	6	dBm
	OSC_{IN}	V_{OSC}	0.5	—	—	V_{p-p}
High-level input voltage	Except f_{IN} and OSC_{IN}	V_{IH}	$V_{CC} \times 0.7$	—	—	V
Low-level input voltage		V_{IL}	—	—	$V_{CC} \times 0.3$	V
High-level input current	Data, clock	I_{IH}	—	1.0	—	μA
Low-level input current		I_{IL}	—	-1.0	—	μA
Input current	OSC_{IN}	I_{OSC}	—	± 50	—	μA
	LE, FC	I_{LE}	—	-60	—	μA
High-level output voltage	Except D_o and OSC_{OUT}	V_{OH}^{*5}	2.2	—	—	V
Low-level output voltage		V_{OL}	—	—	0.4	V
N-channel open drain cutoff current	$D_o, \phi P^{*6}$	I_{OFF}	—	—	1.1	μA
Output current	Except D_o and OSC_{OUT}	I_{OH}	-1.0	—	—	mA
		I_{OL}	1.0	—	—	mA
Analog switch on resistance		R_{ON}	—	25	—	Ω

*1: $f_{IN} = 1.1\text{ GHz}$, $OSC_{IN} = 12\text{ MHz}$, $V_{CC} = 3\text{V}$. Inputs are grounded and outputs are open.

*2: AC coupling. Minimum operating frequency is measured when a capacitor 1000pF.

*3: $V_{CC} = 4.0\text{ to }5.5\text{V}$, 50 (Ω)

*4: $V_{CC} = 2.7\text{ to }4.0\text{V}$, 50 (Ω)

*5: $V_{CC} = 3\text{V}$

*6: $V_P = V_{CC}\text{ to }8\text{V}$, $V_{OOP} = \text{GND to }8\text{V}$

MEASUREMENT CIRCUIT

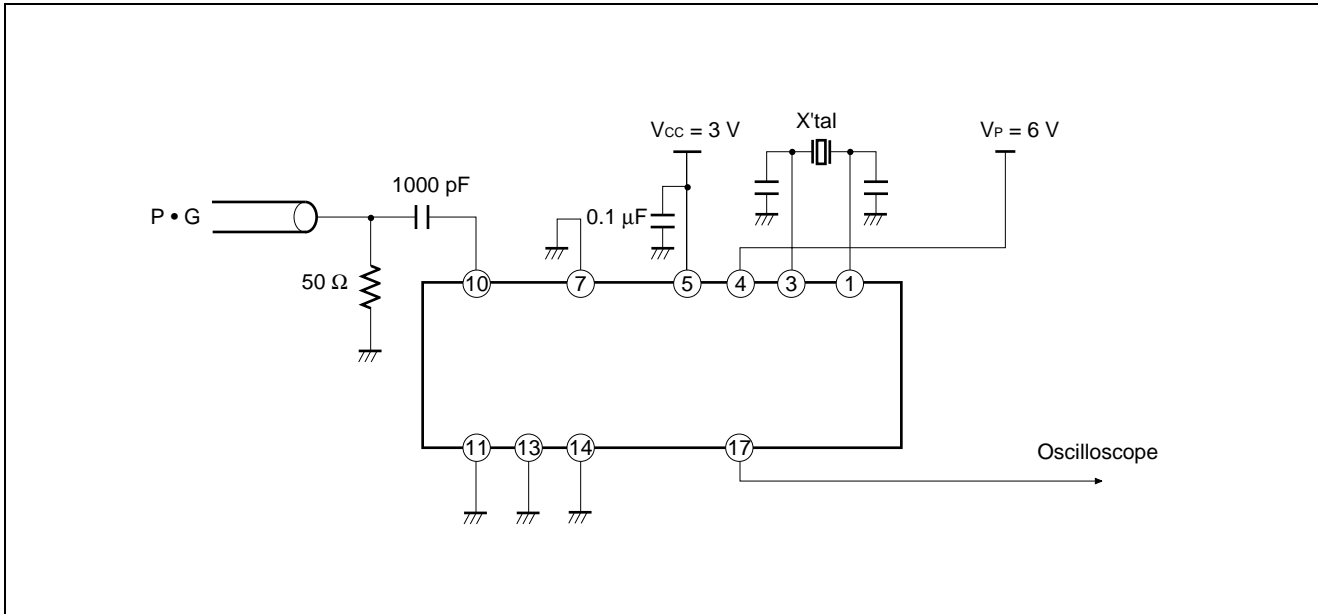

MB1511

■ TYPICAL APPLICATION EXAMPLE

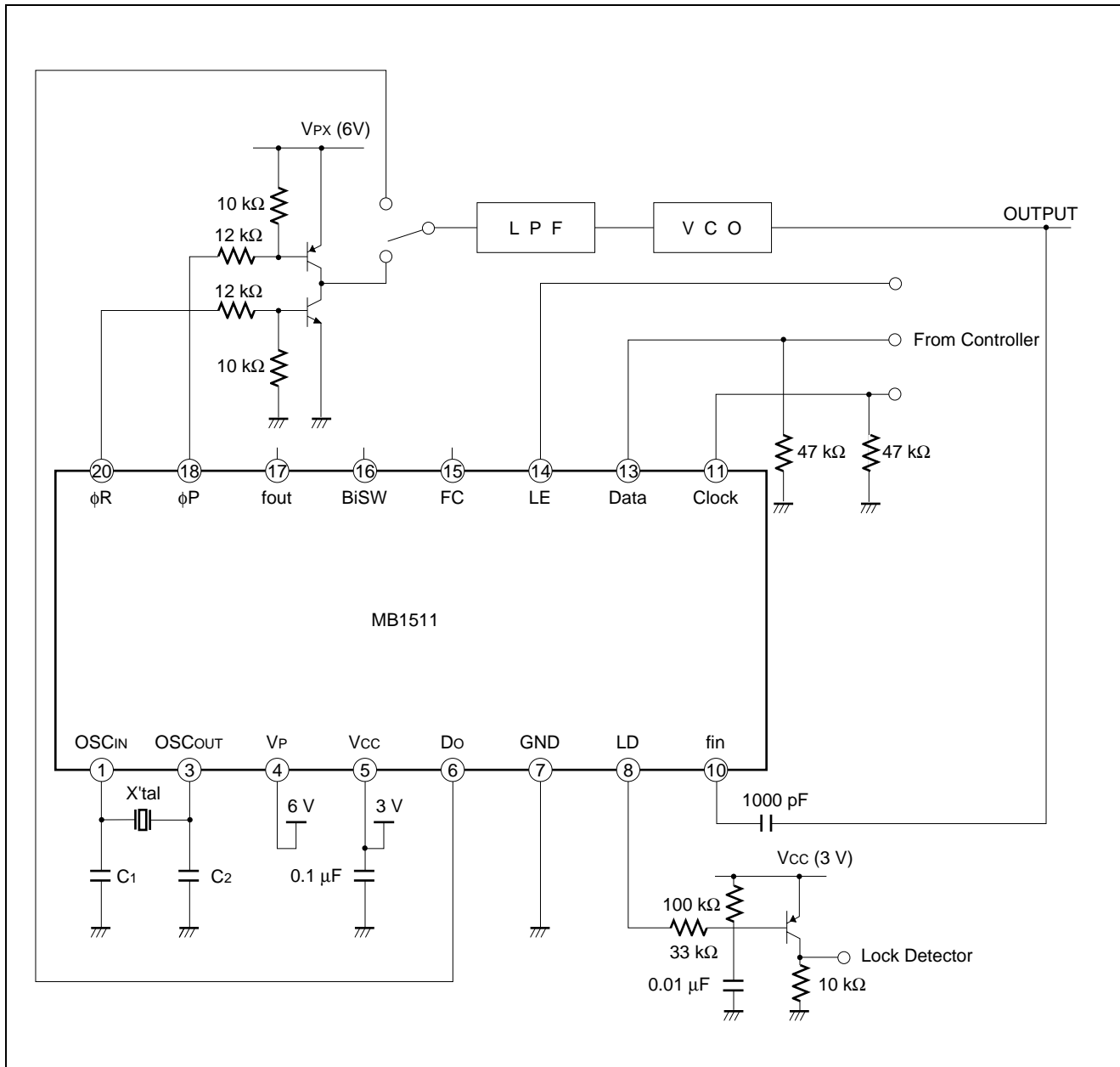

V_{PX}, V_P : 8 V max.

C_1, C_2 : Depends on crystal oscillator

LE, FC : With internal pull up resistor

ϕP : Open drain output

■ ORDERING INFORMATION

Part number	Package	Remarks
MB1511PFV	20-pin plastic SSOP (FPT-20P-M03)	

MB1511

■ PACKAGE DIMENSION

20 pin, Plastic SSOP
(FPT-20P-M03)

Note1) *: This dimension does not include resin protrusion.
Note2) Pins width and pins thickness include plating thickness.

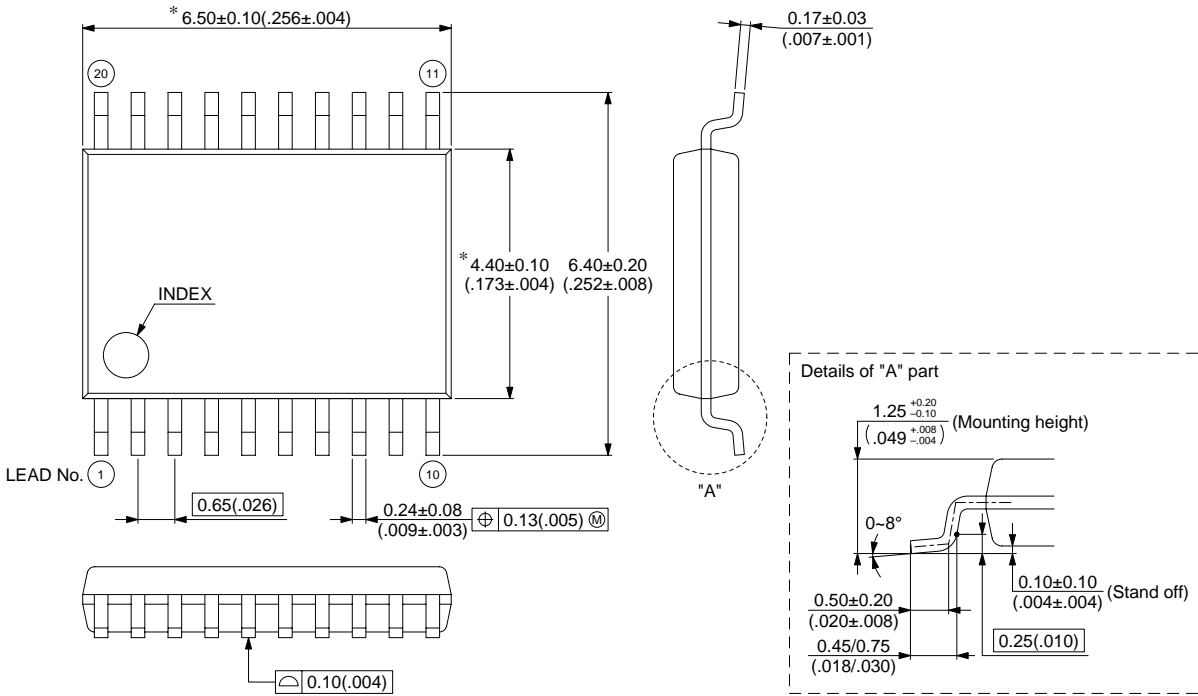

© 1999 FUJITSU LIMITED F20012S-3C-5

Dimensions in mm (inches).

FUJITSU LIMITED

All Rights Reserved.

The contents of this document are subject to change without notice. Customers are advised to consult with FUJITSU sales representatives before ordering.

The information and circuit diagrams in this document are presented as examples of semiconductor device applications, and are not intended to be incorporated in devices for actual use. Also, FUJITSU is unable to assume responsibility for infringement of any patent rights or other rights of third parties arising from the use of this information or circuit diagrams.

The products described in this document are designed, developed and manufactured as contemplated for general use, including without limitation, ordinary industrial use, general office use, personal use, and household use, but are not designed, developed and manufactured as contemplated (1) for use accompanying fatal risks or dangers that, unless extremely high safety is secured, could have a serious effect to the public, and could lead directly to death, personal injury, severe physical damage or other loss (i.e., nuclear reaction control in nuclear facility, aircraft flight control, air traffic control, mass transport control, medical life support system, missile launch control in weapon system), or (2) for use requiring extremely high reliability (i.e., submersible repeater and artificial satellite).

Please note that Fujitsu will not be liable against you and/or any third party for any claims or damages arising in connection with above-mentioned uses of the products.

Any semiconductor devices have an inherent chance of failure. You must protect against injury, damage or loss from such failures by incorporating safety design measures into your facility and equipment such as redundancy, fire protection, and prevention of over-current levels and other abnormal operating conditions.

If any products described in this document represent goods or technologies subject to certain restrictions on export under the Foreign Exchange and Foreign Trade Law of Japan, the prior authorization by Japanese government will be required for export of those products from Japan.