

VOLTAGE REGULATOR

MB3756

May 1988
Edition 2.0

VOLTAGE REGULATOR

The Fujitsu MB3756 monolithic voltage regulator with three outputs is fabricated with a bipolar linear IC technology. Two alternately exchangeable outputs are provided for two stabilized output levels and controlled by an external control signal. Switching noise is prevented by internal circuitry that is suitable for switching between modes such as transmitting and receiving or AM and FM. The MB3756 is packaged in an 8-pin single-in-line package with a heat radiation fin to allow large power consumption.

- No need for external components
- Good balance between three outputs
- On-chip noise protection circuitry
- On-chip overload current protection and thermal protection circuitry
- Good mountability
- High output current : 200 mA typical for V₀₂ output
 : 100 mA typical for V₀₀, V₀₁ outputs

ABSOLUTE MAXIMUM RATINGS (see NOTE) TA = 25°C

Rating	Symbol	Value	Unit
Input Voltage	V _{IN}	18	V
Power Dissipation	P _D	1 *1	W
		4 *2	W
Operating Temperature	T _C	-20 to +75	°C
Storage Temperature	T _{STG}	-55 to +125	°C

Notes: *1 No Heat Sink (TA ≤ 70°C)
 *2 Infinite Heat Sink (TA ≤ 70°C)
 Permanent device damage may occur if the above Absolute Maximum Ratings are exceeded. Functional operation should be restricted to the conditions as detailed in the operational sections of this data sheet. Exposure to absolute maximum rating conditions for extended periods may affect device reliability.

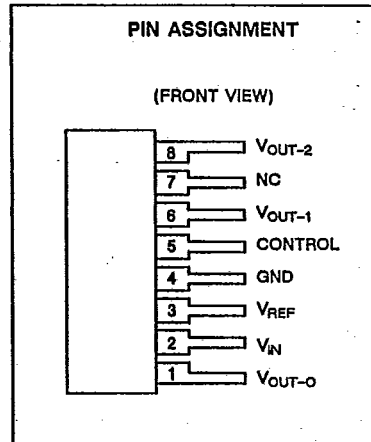
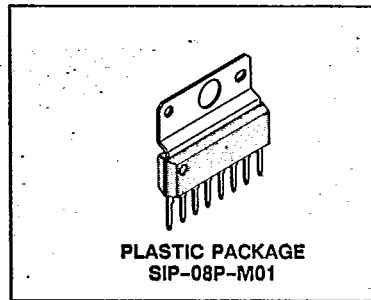

This device contains circuitry to protect the inputs against damage due to high static voltages or electric fields. However, it is advised that normal precautions be taken to avoid application of any voltage higher than maximum rated voltages to this high impedance circuit.



MB3756

T-58-11-13

Fig. 1 — MB3756 EQUIVALENT CIRCUIT

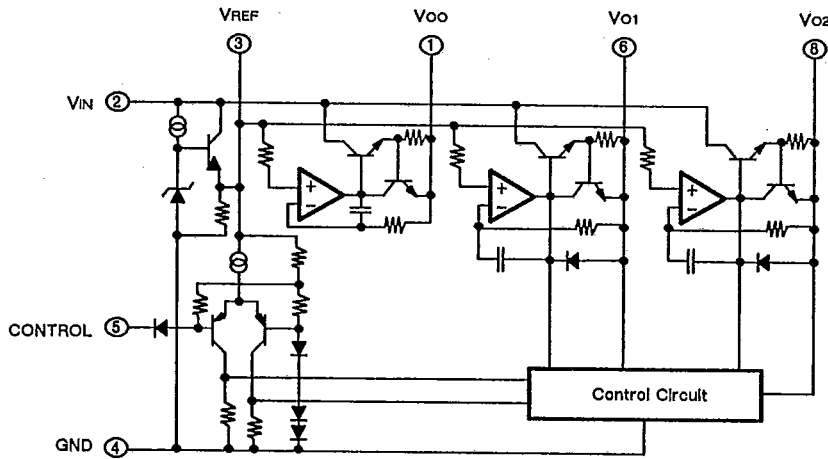

RECOMMENDED OPERATING CONDITIONS

Parameter	Symbol	Value			Unit
		Min	Typ	Max	
Input Voltage	V _{IN}	11	-	16	V
Load Current	I _{L1} *1	0	-	100	mA
	I _{L2} *2	0	-	200	mA
Operating Temperature	T _c	-20	-	+75	°C

Note : *1 V₀₀, V₀₁
 *2 V₀₂

ELECTRICAL CHARACTERISTICS

T-58-11-13

(TC = 25°C, VIN = 14 V, RLO = RLI = 200 Ω, RL2 = 100 Ω)

Parameter	Symbol	Condition	Values			Unit
			Min	Typ	Max	
Input Voltage	VIN	—	10.6	—	18	V
Output Voltage	Vo	—	7.8	8.2	8.6	V
Input Regulation	—	11 V ≤ VIN ≤ 18 V	—	20	100	mV
Load Regulation	—	(V00, V01) 1 mA ≤ IL ≤ 100 mA	—	15	80	mV
	—	(V02) 1 mA ≤ IL ≤ 200 mA	—	20	100	mV
	—	(V00, V01) 1 mA ≤ IL ≤ 100 mA VIN = 11.5 V	—	20	100	mV
	—	(V02) 1 mA ≤ IL ≤ 200 mA VIN = 11.5 V	—	30	150	mV
Bias Current	IB	VIN = 18 V	—	6	10	mA
Ripple Rejection Ratio	—	f = 100 Hz	—	60	—	dB
Output Noise Voltage	—	10 Hz ≤ f ≤ 100kHz, CR = 10 μF	—	40	—	μV
Input to Output Voltage Differential	VIN-V0	—	—	1.7	—	V
Temperature Coefficient of Output Voltage	TCV0	—	—	-0.4	—	mV/C°
Output Voltage Deviation	ΔV0	—	—	10	50	mV
Short Circuit Output Current	ISC	(V00, V01)	—	200	—	mA
		(V02)	—	350	—	mA
Output Voltage	V01L	VIC = 0.8 V	0	—	0.2	V
	V02L	VIC = 0.8 V	7.8	8.2	8.6	V
	V01H	VIC = 2.0 V	7.8	8.2	8.6	V
	V02H	VIC = 2.0 V	0	—	0.2	V
Control Input Current	IL	VICL = 0 V	—	-0.2	-1.0	mA
	IH	VICH = 18V, VIN = 18V	—	—	10	μA



T-58-11-13



MB3756

TYPICAL PERFORMANCE CHARACTERISTICS

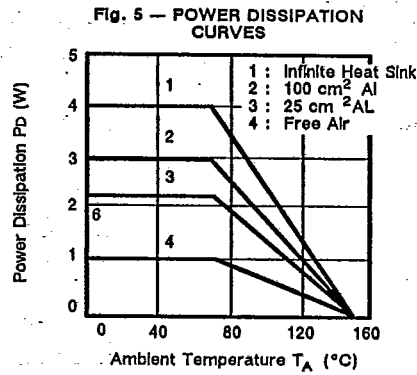
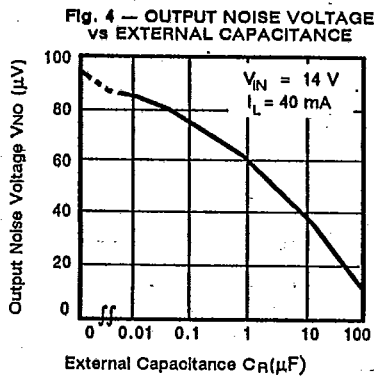
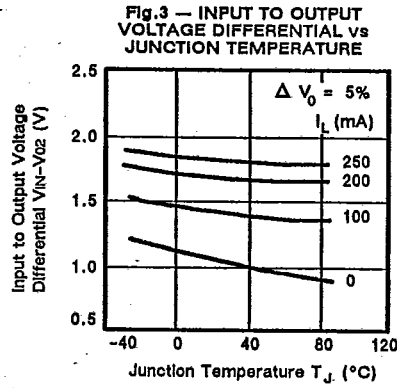
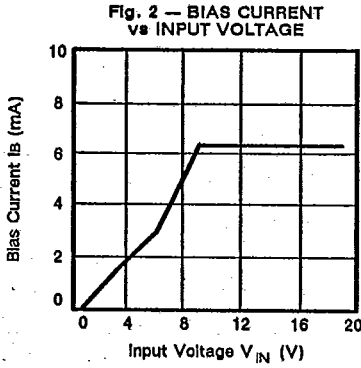

FUJITSU
 MB3756
 T-58-11-13

TYPICAL PERFORMANCE CHARACTERISTICS (Continued)

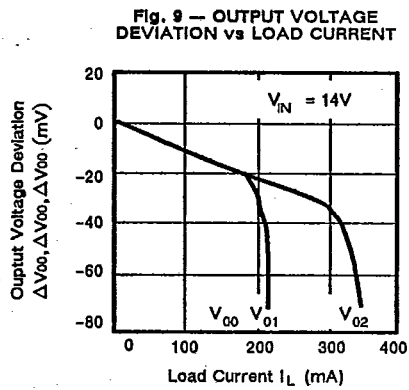
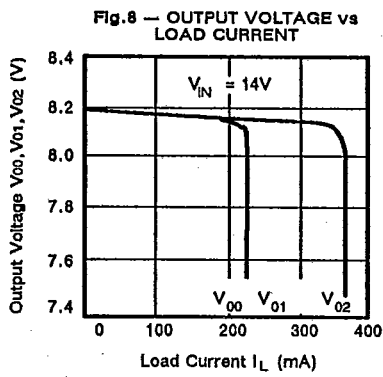
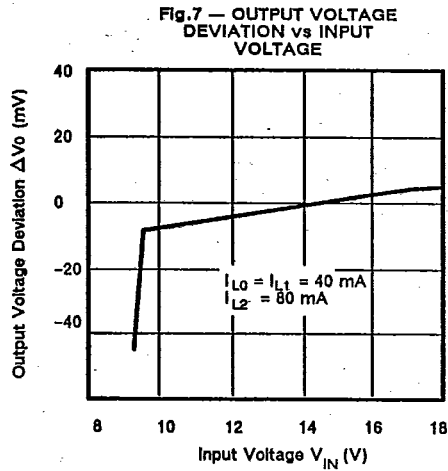
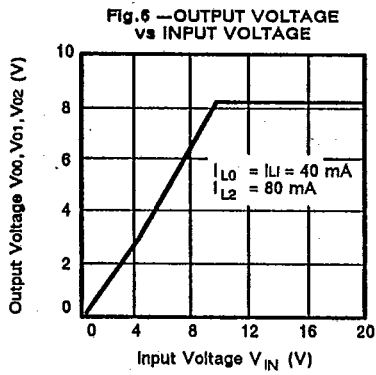



MB3756

TYPICAL PERFORMANCE CHARACTERISTICS (Continued)

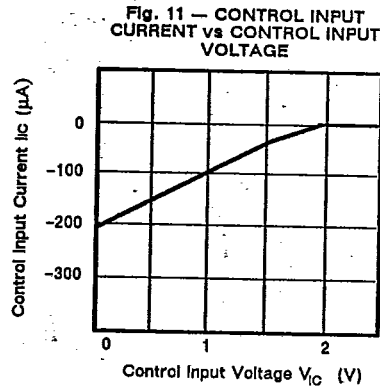
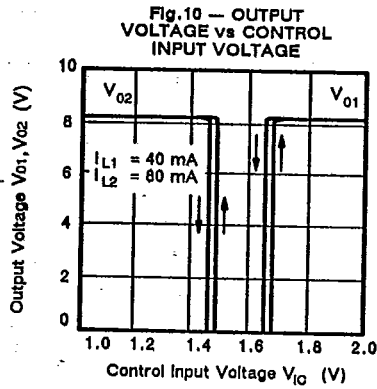
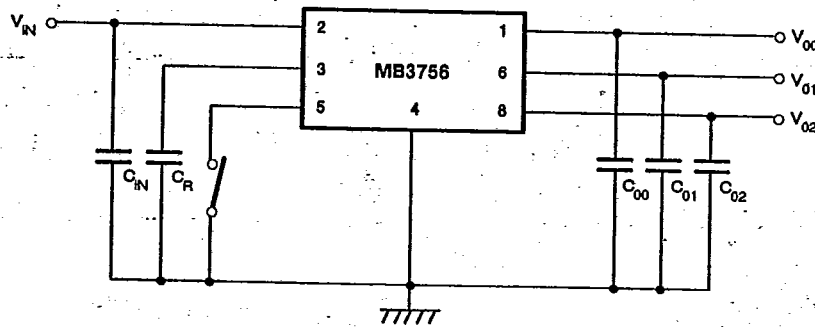

Fig. 12 — APPLICATION CIRCUIT



Note: C_{IN} is required if the regulator is located at a distance from the power supply filter.
 C_L improves output noise and ripple rejection.
 C_{00}, C_{01}, C_{02} improve transient response.

