

ASSP

DUAL REVERSIBLE MOTOR DRIVER

MB3863

■ DESCRIPTION

The MB3863 is an IC motor driver with two independent reverse control functions. It drives motor drives of front-loading VCRs and auto-reverse cassette decks and stepping motors by reversible control at TTL and CMOS levels. A heat protection circuit is incorporated to prevent damage by overheating.

■ FEATURES

- Wide voltage range: $V_{CC} = +4$ to $+36V$
- Motor drive current: 500 mA (1.2 A for surge current)
- Two internal independent drivers
- Internal heat protection circuit
- Control at TTL and CMOS level
- Stand-by mode
- Brake function to stop motors
- Surge absorption diode
- Stepping motor application
- Symmetrical pin layout

■ PACKAGE

Plastic ZIP, 17 pin

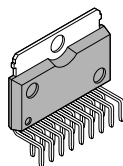

(ZIP-17P-M03)

Plastic ZIP, 20 pin

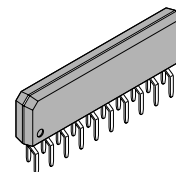

(ZIP-20P-M01)

MB3863

■ PIN ASSIGNMENT

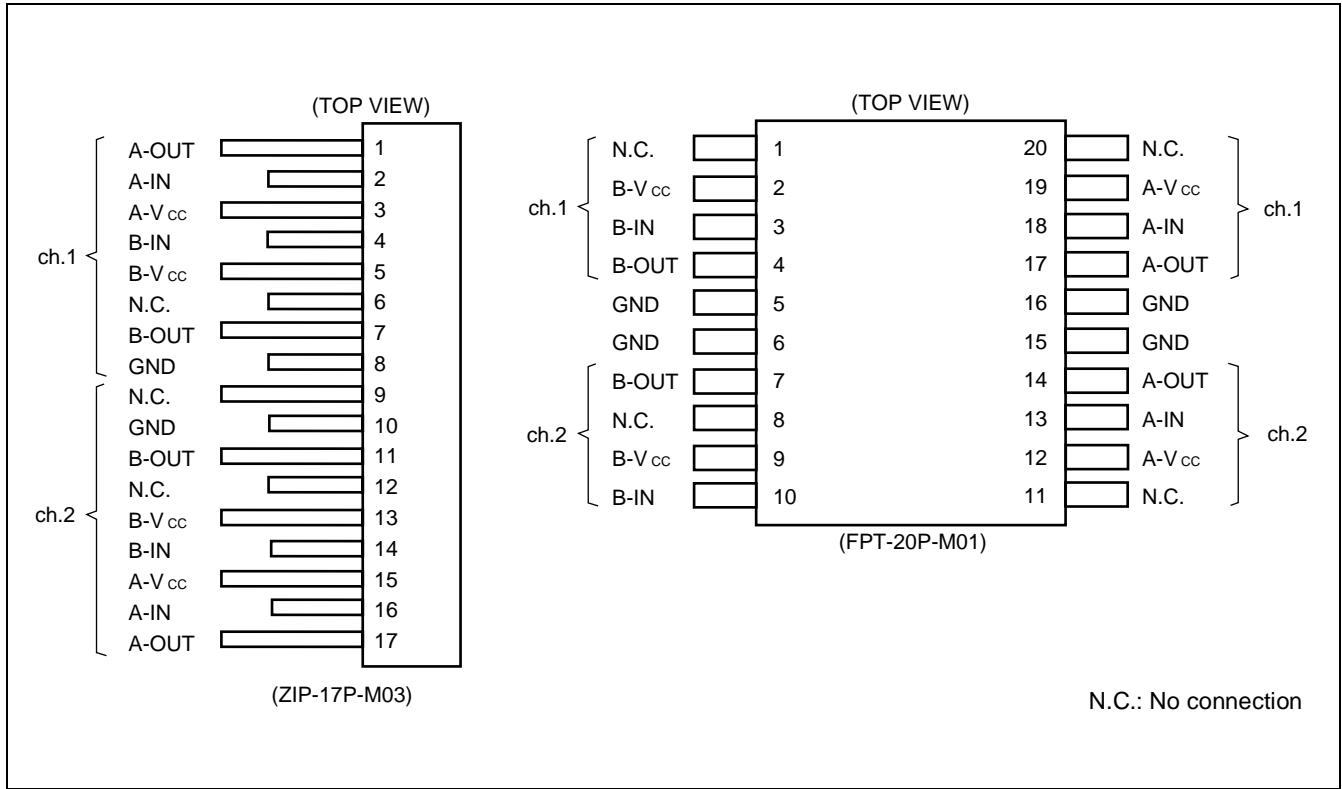

■ BLOCK DIAGRAM

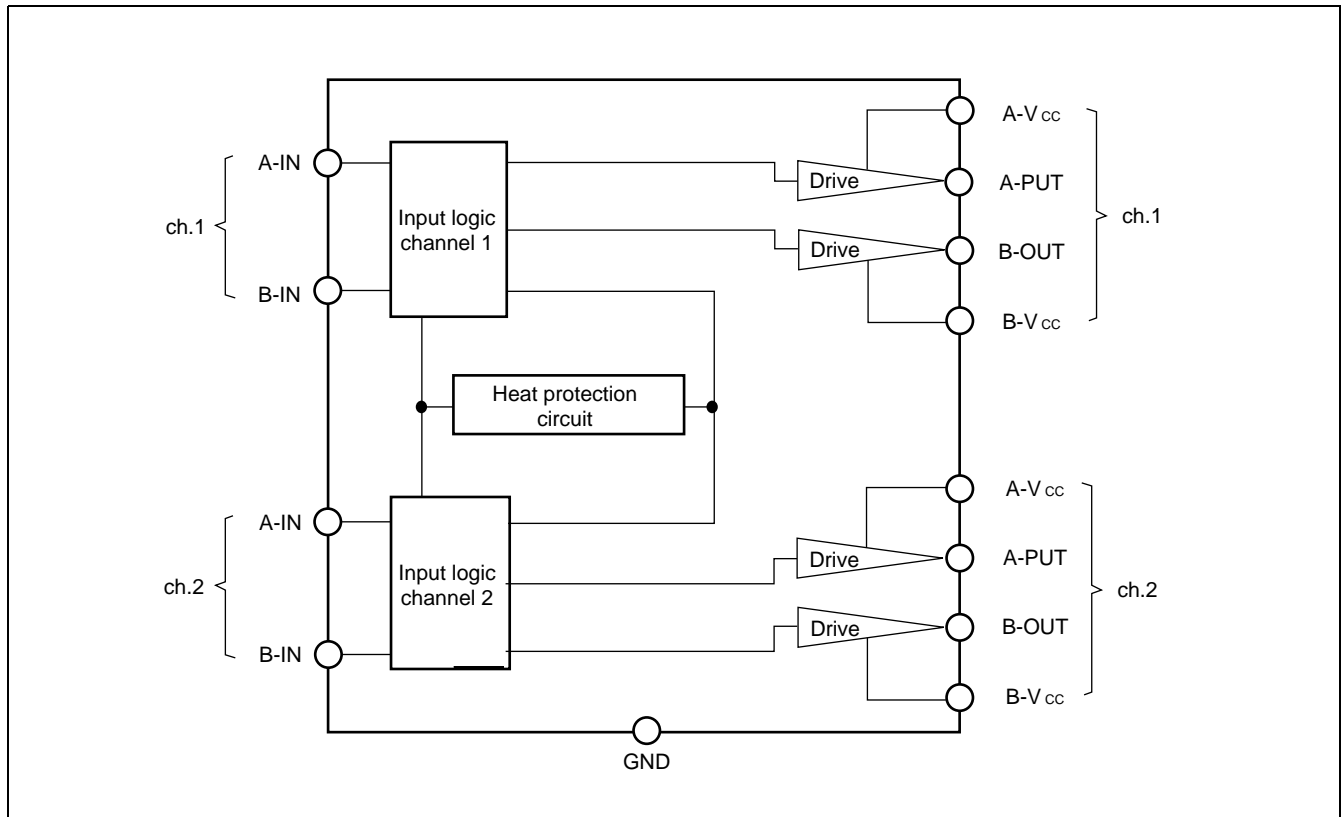

■ ABSOLUTE MAXIMUM RATINGS

Parameter	Symbol	Ratings	Unit
Supply Voltage	V _{CC}	+38	V
Output Current	I _O	550	mA
Maximum Output Current (within 5 ms)	I _{Omax}	1.2	A
Allowable Loss	P _D	6.5 (ZIP-17)	W
		1.6 (SOP-20)	
Operating Temperature	T _{OP}	-20 to +75	°C
Storage Temperature	T _{stg}	-55 to +150	°C

■ RECOMMENDED OPERATING CONDITIONS

Parameter	Symbol	Ratings	Unit	
Supply Voltage	V _{CC}	+4 to +36	V	
Output Current	I _O	0 to 500	mA	
Input Voltage	High level	V _{IH}	2.4 to V _{CC} +0.3	V
	Low level	V _{IL}	0 to 0.4	V

■ ELECTRICAL CHARACTERISTICS

(V_{CC} = 24V, V_{IN} = 2.4V, T_a = +25°C)

Parameter	Symbol	Conditions	Values			Unit	
			Min.	Typ.	Max.		
Stand-by Supply Voltage	I _{CC0}	V _{CC} = +24V, V _{IA} = V _{IB} = 0V	—	—	100	μA	
Supply Voltage	I _{CC1}	I _O = 0 mA	—	24	38	mA	
	I _{CC2}	I _O = 500 mA	—	24	—	mA	
	I _{CC3}	I _O = 0 mA, V _{IA} = V _{IB} = +2.4V	—	37	—	mA	
Output Voltage	High level	V _{OH}	I _O = 500 mA	22.65	23	—	V
	Low level	V _{OL}	I _O = 500 mA	—	0.35	0.65	V
Saturated Output Voltage	V _{SAT}	I _O = 500 mA	—	1.35	2.00	V	
Input Current	T	V _{IN} = +2.4V	—	250	400	μA	
Surge Absorption Diode Voltage in Forward Direction	I _{IH}	I _O = 1.2A	—	2.0	—	V	
	V _F						

MB3863

■ OPERATIONS

1. Forward and Reverse

Switching control mode A or B pairs Q2 and Q3, or Q1 and Q4, respectively, while reversing the supply current to the motor for each switching. When Q2 and Q3 are in use, B-OUT and A-OUT are High level and Low level, respectively. In this case, current flows B-OUT motor A-OUT, causing forward operation as described in the table below.

When Q1 and Q4 are in use, current flows in the reverse direction to the above flow, causing reverse motor operation.

2. Brake

Control mode C operates Q3 and Q4 while stopping Q1 and Q3.

Since A-OUT and B-OUT are held at Low level, both poles of the motor are short-circuited and the motor is stopped.

3. Stand-by

Control mode D turns Q1 to Q4 OFF and the motor has no current flow.

In this mode, the power current is less than 100 μ A.

Mode	Input mode*		Operation state of output transistor				State of output pin		Output operation mode
	A=IN	B=IN	Q1	Q2	Q3	Q4	A-OUT	B-OUT	
A	1	0	OFF	ON	ON	OFF	L	H	Forward (Reverse)
B	0	1	ON	OFF	OFF	ON	H	L	Reverse (Forward)
C	1	1	OFF	ON	OFF	ON	L	L	Brake
D	0	0	OFF	OFF	OFF	OFF	—	—	Open (High impedance)

* : Input mode: -1: +2.4V min.
-0: +0.4V max.

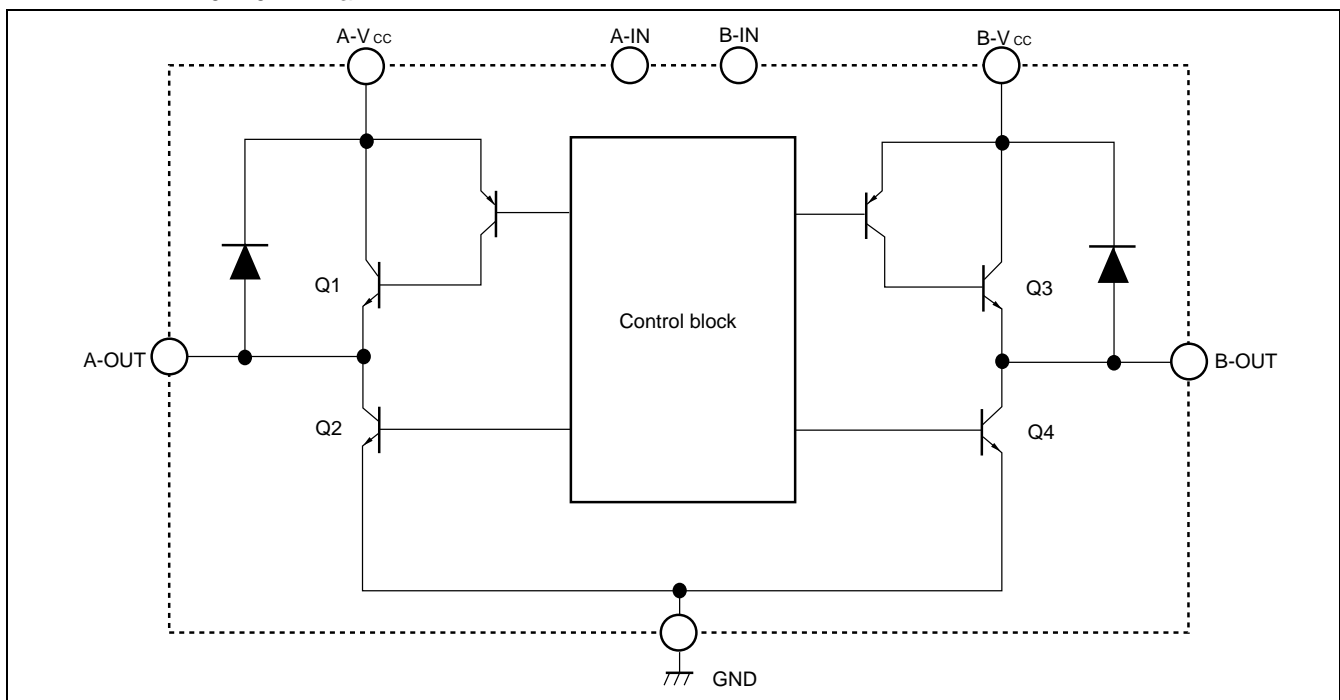

■ TYPICAL CONNECTION

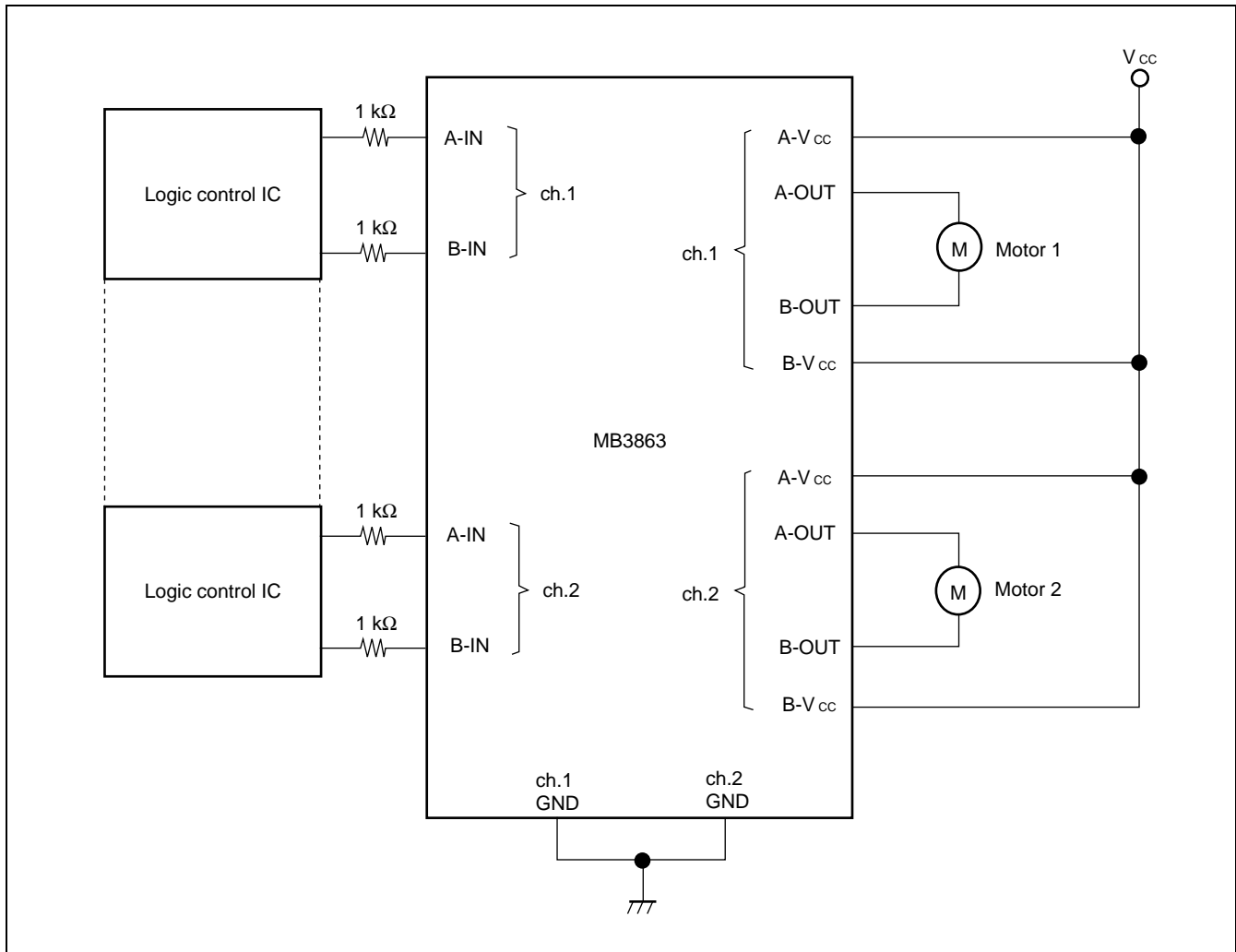

Note: If input voltage is applied when power is not supplied, over-current flows into the device via the input pins. In this case, connect a resistor of at least 1 kΩ in series with the input pins to prevent passage of a large current.

MB3863

TYPICAL CHARACTERISTIC CURVES

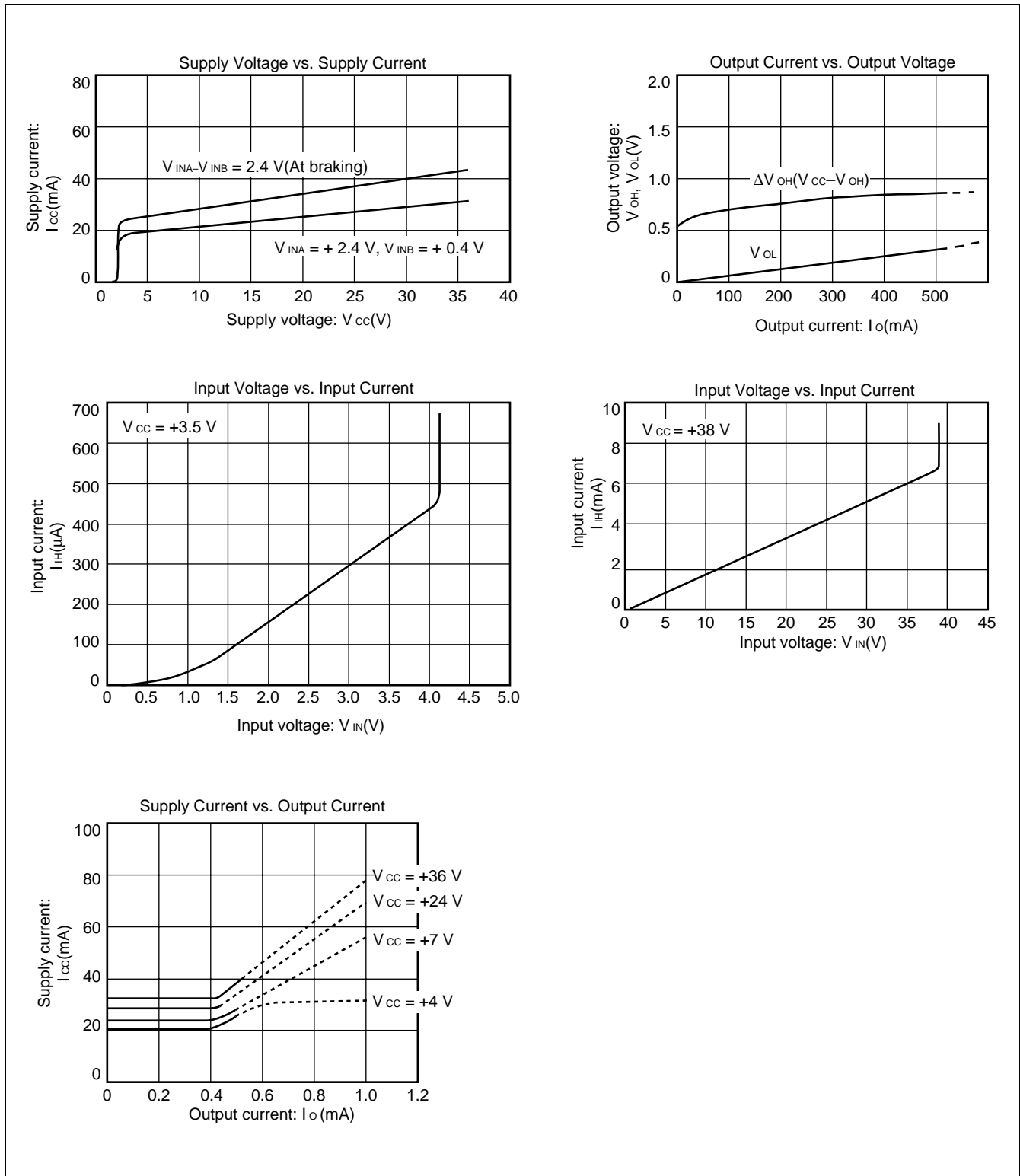

Note: The above characteristic curves are at $T_a = +25^\circ\text{C}$

POWER DERATING CHARACTERISTICS

(1) ZIP-17P

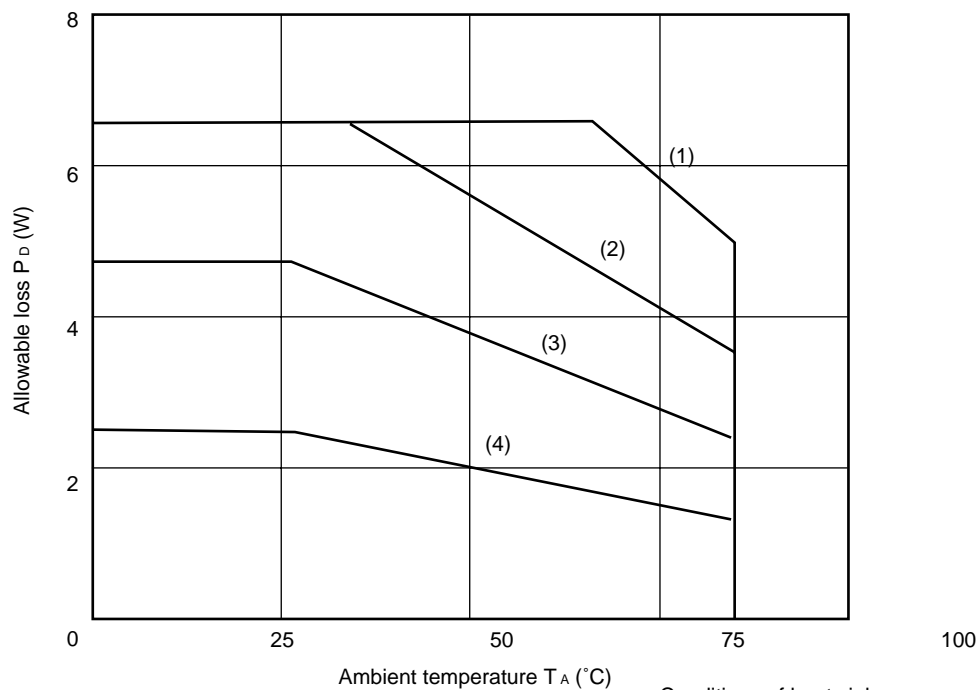

Conditions of heat sink:

- (1) With 50-cm square and 2-mm thickness plate
- (2) With 25-cm square and 2-mm thickness plate
- (3) With 10-cm square and 2-mm thickness plate
- (4) Without heat sink

(2) SOP-20P

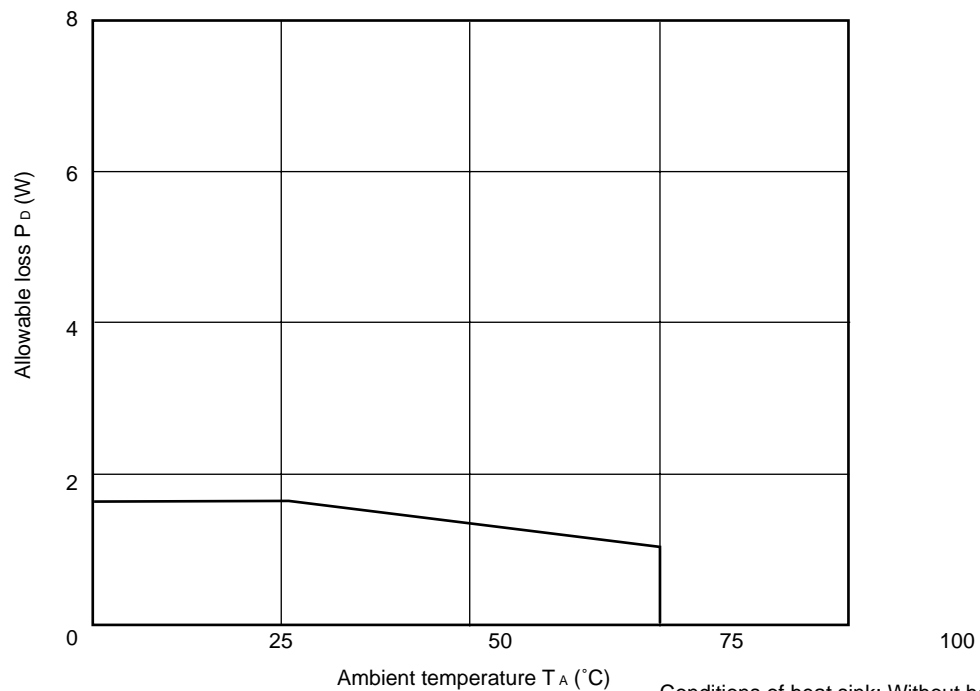

Conditions of heat sink: Without heat sink plate

MB3863

■ PACKAGE DIMENSIONS

Plastic ZIP, 17 pin
(ZIP-17P-M03)

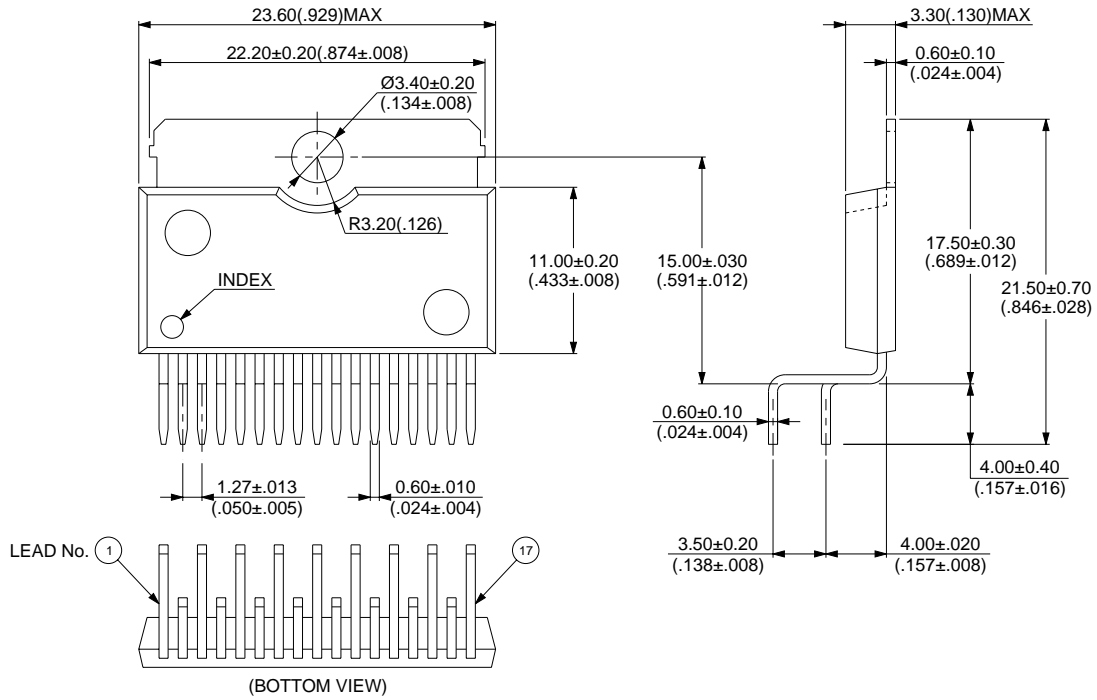

(Continued)

(Continued)

Plastic ZIP, 20 pin
(ZIP-20P-M01)

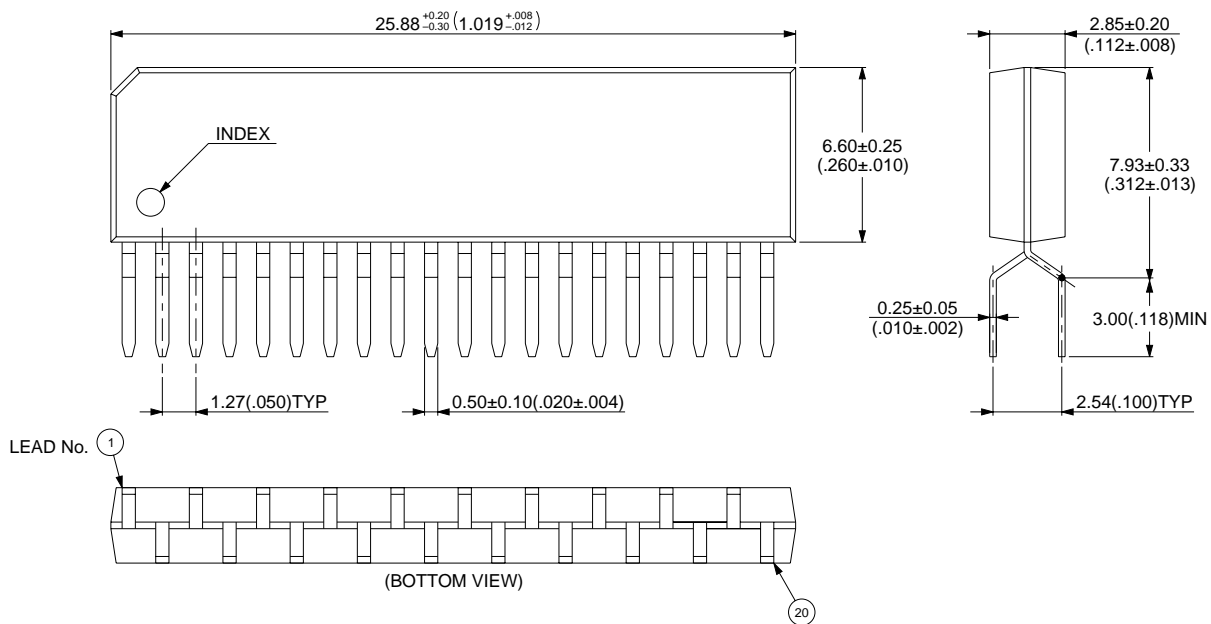

© 1994 FUJITSU LIMITED Z20001S-4C-2

Dimensions in mm (inches)

FUJITSU LIMITED

For further information please contact:

Japan

FUJITSU LIMITED
Corporate Global Business Support Division
Electronic Devices
KAWASAKI PLANT, 4-1-1, Kamikodanaka
Nakahara-ku, Kawasaki-shi
Kanagawa 211-8588, Japan
Tel: (044) 754-3763
Fax: (044) 754-3329

<http://www.fujitsu.co.jp/>

North and South America

FUJITSU MICROELECTRONICS, INC.
Semiconductor Division
3545 North First Street
San Jose, CA 95134-1804, USA
Tel: (408) 922-9000
Fax: (408) 922-9179

Customer Response Center
Mon. - Fri.: 7 am - 5 pm (PST)
Tel: (800) 866-8608
Fax: (408) 922-9179

<http://www.fujitsumicro.com/>

Europe

FUJITSU MIKROELEKTRONIK GmbH
Am Siebenstein 6-10
D-63303 Dreieich-Buchsschlag
Germany
Tel: (06103) 690-0
Fax: (06103) 690-122

<http://www.fujitsu-edc.com/>

Asia Pacific

FUJITSU MICROELECTRONICS ASIA PTE LTD
#05-08, 151 Lorong Chuan
New Tech Park
Singapore 556741
Tel: (65) 281-0770
Fax: (65) 281-0220

<http://www.fmap.com.sg/>

F9803

© FUJITSU LIMITED Printed in Japan

All Rights Reserved.

The contents of this document are subject to change without notice. Customers are advised to consult with FUJITSU sales representatives before ordering.

The information and circuit diagrams in this document presented as examples of semiconductor device applications, and are not intended to be incorporated in devices for actual use. Also, FUJITSU is unable to assume responsibility for infringement of any patent rights or other rights of third parties arising from the use of this information or circuit diagrams.

FUJITSU semiconductor devices are intended for use in standard applications (computers, office automation and other office equipment, industrial, communications, and measurement equipment, personal or household devices, etc.).

CAUTION:

Customers considering the use of our products in special applications where failure or abnormal operation may directly affect human lives or cause physical injury or property damage, or where extremely high levels of reliability are demanded (such as aerospace systems, atomic energy controls, sea floor repeaters, vehicle operating controls, medical devices for life support, etc.) are requested to consult with FUJITSU sales representatives before such use. The company will not be responsible for damages arising from such use without prior approval.

Any semiconductor devices have inherently a certain rate of failure. You must protect against injury, damage or loss from such failures by incorporating safety design measures into your facility and equipment such as redundancy, fire protection, and prevention of over-current levels and other abnormal operating conditions.

If any products described in this document represent goods or technologies subject to certain restrictions on export under the Foreign Exchange and Foreign Trade Control Law of Japan, the prior authorization by Japanese government should be required for export of those products from Japan.