

MC34001, B MC34002, B MC34004, B

JFET Input Operational Amplifiers

These low cost JFET input operational amplifiers combine two state-of-the-art analog technologies on a single monolithic integrated circuit. Each internally compensated operational amplifier has well matched high voltage JFET input devices for low input offset voltage. The BIFET technology provides wide bandwidths and fast slew rates with low input bias currents, input offset currents, and supply currents.

The Motorola BIFET family offers single, dual and quad operational amplifiers which are pin-compatible with the industry standard MC1741, MC1458, and the MC3403/LM324 bipolar devices. The MC34001/34002/34004 series are specified from 0° to +70°C.

- Input Offset Voltage Options of 5.0 mV and 10 mV Maximum
- Low Input Bias Current: 40 pA
- Low Input Offset Current: 10 pA
- Wide Gain Bandwidth: 4.0 MHz
- High Slew Rate: 13 V/μs
- Low Supply Current: 1.4 mA per Amplifier
- High Input Impedance: 10¹² Ω
- High Common Mode and Supply Voltage Rejection Ratios: 100 dB
- Industry Standard Pinouts

JFET INPUT OPERATIONAL AMPLIFIERS

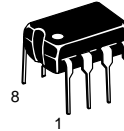

P SUFFIX
PLASTIC PACKAGE
CASE 626



D SUFFIX
PLASTIC PACKAGE
CASE 751
(SO-8)

PIN CONNECTIONS

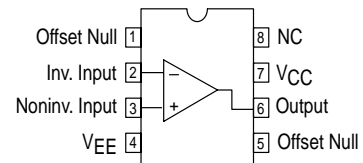

MC34001 (Top View)

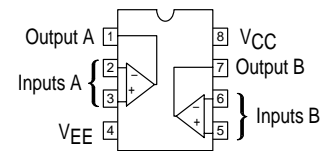

MC34002 (Top View)

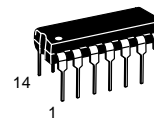

P SUFFIX
PLASTIC PACKAGE
CASE 646

PIN CONNECTIONS

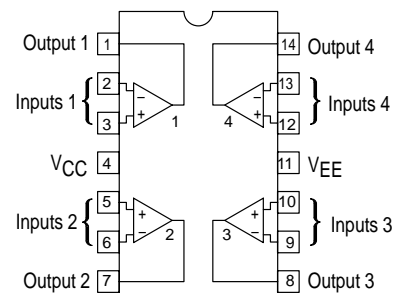

MC34004 (Top View)

ORDERING INFORMATION

Op Amp Function	Device	Operating Temperature Range	Package
Single	MC34001BD, D	$T_A = 0^\circ \text{ to } +70^\circ\text{C}$	SO-8
	MC34001BP, P		Plastic DIP
Dual	MC34002BD, D	$T_A = 0^\circ \text{ to } +70^\circ\text{C}$	SO-8
	MC34002BP, P		Plastic DIP
Quad	MC34004BP, P	$T_A = 0^\circ \text{ to } +70^\circ\text{C}$	Plastic DIP

MC34001, B MC34002, B MC34004, B

MAXIMUM RATINGS

Rating	Symbol	Value	Unit
Supply Voltage	V_{CC}, V_{EE}	± 18	V
Differential Input Voltage (Note 1)	V_{ID}	± 30	V
Input Voltage Range	V_{IDR}	± 16	V
Open Short Circuit Duration	t_{SC}	Continuous	
Operating Ambient Temperature Range	T_A	0 to +70	°C
Operating Junction Temperature	T_J	150	°C
Storage Temperature Range	T_{stg}	-65 to +150	°C

NOTES: 1. Unless otherwise specified, the absolute maximum negative input voltage is equal to the negative power supply.

ELECTRICAL CHARACTERISTICS ($V_{CC} = +15$ V, $V_{EE} = -15$ V, $T_A = 25^\circ\text{C}$, unless otherwise noted.)

Characteristics	Symbol	Min	Typ	Max	Unit
Input Offset Voltage ($R_S \leq 10$ k) MC3400XB MC3400X	V_{IO}	— —	3.0 5.0	5.0 10	mV
Average Temperature Coefficient of Input Offset Voltage $R_S \leq 10$ k, $T_A = T_{low}$ to T_{high} (Note 2)	$\Delta V_{IO}/\Delta T$	—	10	—	$\mu\text{V}/^\circ\text{C}$
Input Offset Current ($V_{CM} = 0$) (Note 3) MC3400XB MC3400X	I_{IO}	— —	25 25	100 100	pA
Input Bias Current ($V_{CM} = 0$) (Note 3) MC3400XB MC3400X	I_{IB}	— —	50 50	200 200	pA
Input Resistance	r_i	—	10^{12}	—	Ω
Common Mode Input Voltage Range	V_{ICR}	± 11 —	+15 -12	— —	V
Large Signal Voltage Gain ($V_O = \pm 10$ V, $R_L = 2.0$ k) MC3400XB MC3400X	A_{VOL}	50 25	150 100	— —	V/mV
Output Voltage Swing ($R_L \geq 10$ k) ($R_L \geq 2.0$ k)	V_O	± 12 ± 10	± 14 ± 13	— —	V
Common Mode Rejection Ratio ($R_S \leq 10$ k) MC3400XB MC3400X	CMRR	80 70	100 100	— —	dB
Supply Voltage Rejection Ratio ($R_S \leq 10$ k) (Note 4) MC3400XB MC3400X	PSRR	80 70	100 100	— —	dB
Supply Current (Each Amplifier) MC3400XB MC3400X	I_D	— —	1.4 1.4	2.5 2.7	mA
Slew Rate ($A_V = 1.0$)	SR	—	13	—	V/ μs
Gain-Bandwidth Product	GBW	—	4.0	—	MHz
Equivalent Input Noise Voltage ($R_S = 100$ Ω , $f = 1000$ Hz)	e_n	—	25	—	$\text{nV}/\sqrt{\text{Hz}}$
Equivalent Input Noise Current ($f = 1000$ Hz)	i_n	—	0.01	—	$\text{pA}/\sqrt{\text{Hz}}$

NOTES: 2. $T_{low} = 0^\circ\text{C}$ for MC34001/34001B
MC34002
MC34004/34004B
 $T_{high} = +70^\circ\text{C}$ for MC34001/34001B
MC34002
MC34004/34004B

3. The input bias currents approximately double for every 10°C rise in junction temperature, T_J . Due to limited test time, the input bias currents are correlated to junction temperature. Use of a heatsink is recommended if input bias current is to be kept to a minimum.
4. Supply voltage rejection ratio is measured for both supply magnitudes increasing or decreasing simultaneously, in accordance with common practice.

MC34001, B MC34002, B MC34004, B

ELECTRICAL CHARACTERISTICS ($V_{CC} = +15\text{ V}$, $V_{EE} = -15\text{ V}$, $T_A = T_{low}$ to T_{high} [Note 2].)

Characteristics	Symbol	Min	Typ	Max	Unit
Input Offset Voltage ($R_S \leq 10\text{ k}$) MC3400XB MC3400X	V_{IO}	— —	— —	7.0 13	mV
Input Offset Current ($V_{CM} = 0$) (Note 3) MC3400XB MC3400X	I_{IO}	— —	— —	4.0 4.0	nA
Input Bias Current ($V_{CM} = 0$) (Note 3) MC3400XB MC3400X	I_{IB}	— —	— —	8.0 8.0	nA
Common Mode Input Voltage Range	V_{ICR}	± 11	—	—	V
Large Signal ($V_O = \pm 10\text{ V}$, $R_L = 2.0\text{ k}$) MC3400XB MC3400X	A_{VOL}	25 15	— —	— —	V/mV
Output Voltage Swing ($R \geq 10\text{ k}$) ($R \geq 2.0\text{ k}$)	V_O	± 12 ± 10	— —	— —	V
Common Mode Rejection Ratio ($R_S \leq 10\text{ k}$) MC3400XB MC3400X	CMRR	80 70	— —	— —	dB
Supply Voltage Rejection Ratio ($R_S \leq 10\text{ k}$) (Note 4) MC3400XB MC3400X	PSRR	80 70	— —	— —	dB
Supply Current (Each Amplifier) MC3400XB MC3400X	I_D	— —	— —	2.8 3.0	mA

NOTES: 2. $T_{low} = 0^\circ\text{C}$ for MC34001/34001B
 MC34002
 MC34004/34004B
 $T_{high} = +70^\circ\text{C}$ for MC34001/34001B
 MC34002
 MC34004/34004B

3. The input bias currents approximately double for every 10°C rise in junction temperature, T_J . Due to limited test time, the input bias currents are correlated to junction temperature. Use of a heatsink is recommended if input bias current is to be kept to a minimum.

4. Supply voltage rejection ratio is measured for both supply magnitudes increasing or decreasing simultaneously, in accordance with common practice.

Figure 1. Input Bias Current versus Temperature

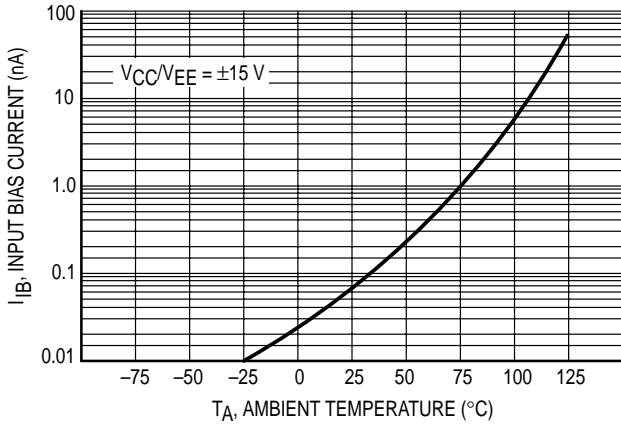

Figure 2. Output Voltage Swing versus Frequency

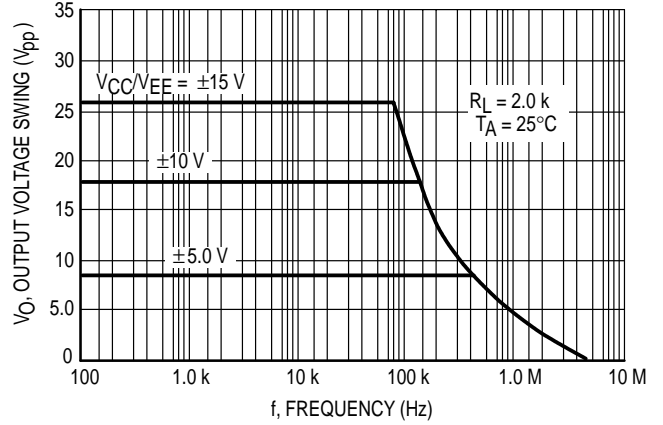

Figure 3. Output Voltage Swing versus Load Resistance

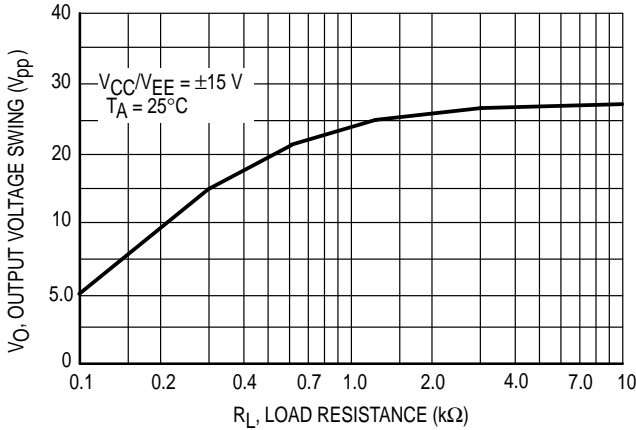

Figure 4. Output Voltage Swing versus Supply Voltage

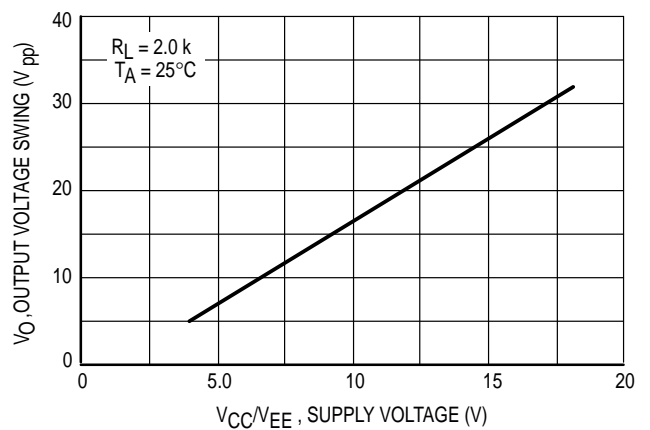

Figure 5. Output Voltage Swing versus Temperature

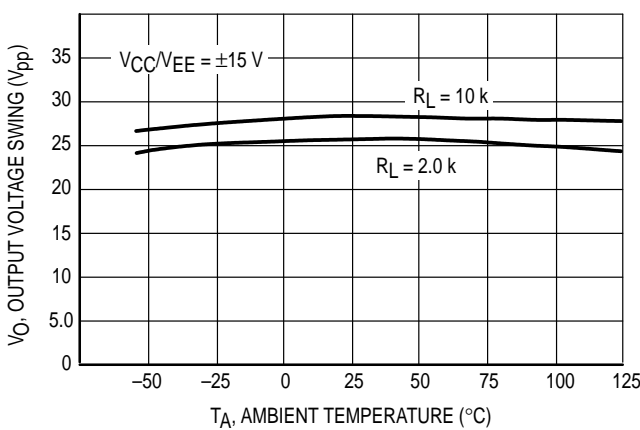

Figure 6. Supply Current per Amplifier versus Temperature

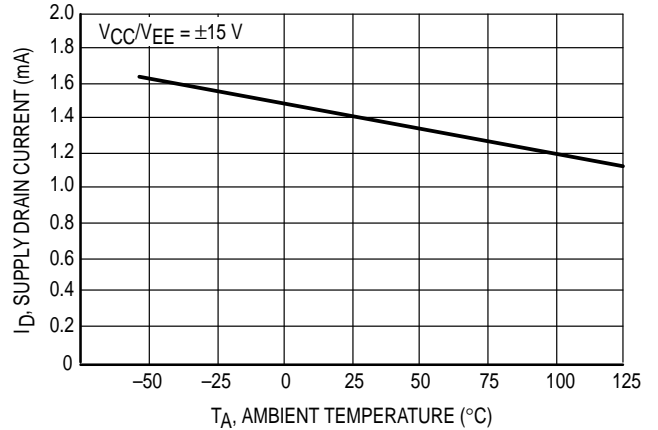

Figure 7. Large-Signal Voltage Gain and Phase Shift versus Frequency

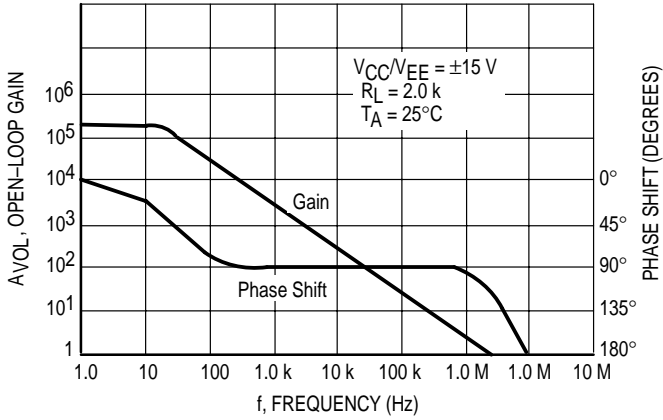

Figure 8. Large-Signal Voltage Gain versus Temperature

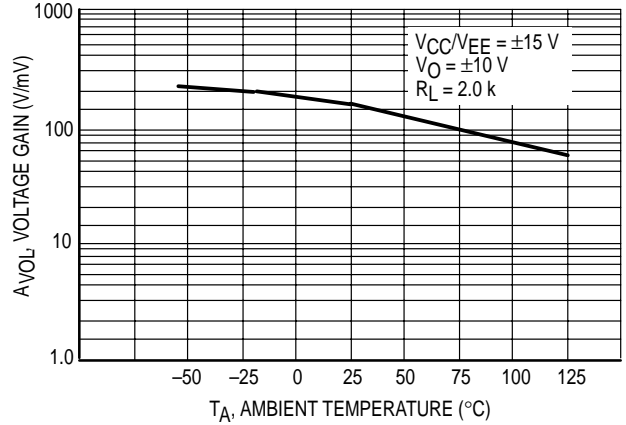

Figure 9. Normalized Slew Rate versus Temperature

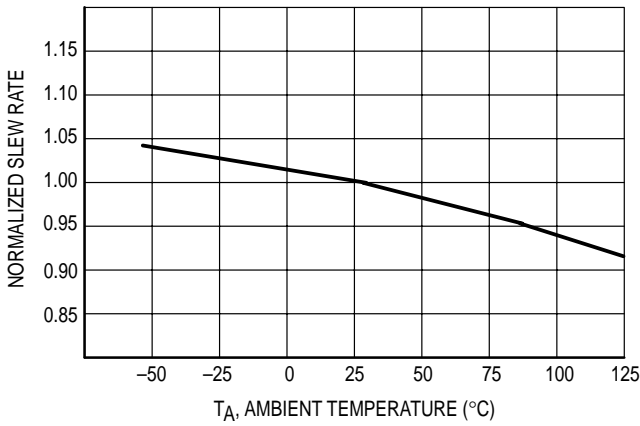

Figure 10. Equivalent Input Noise Voltage versus Frequency

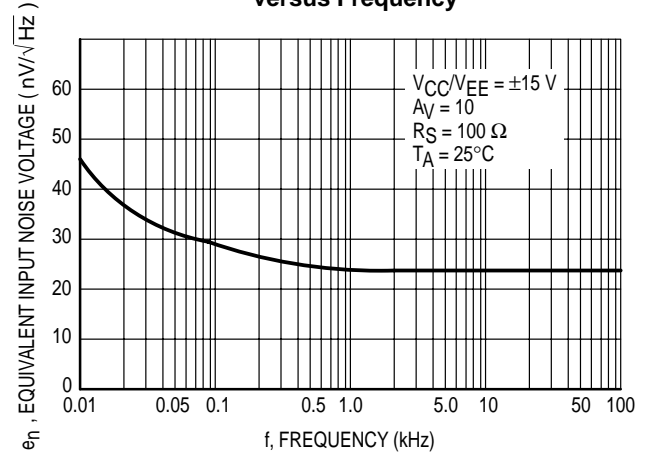
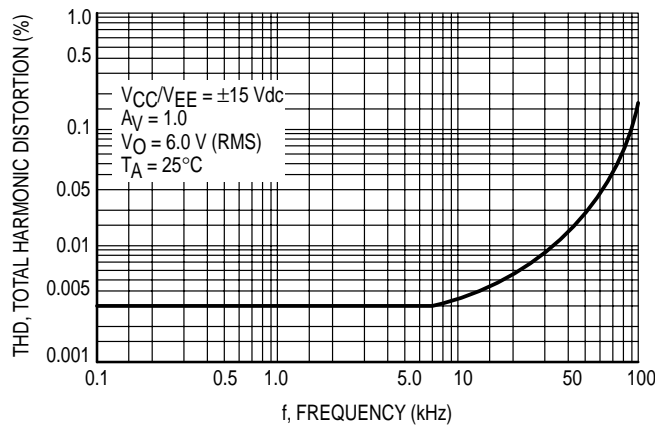

Figure 11. Total Harmonic Distortion versus Frequency



MC34001, B MC34002, B MC34004, B

Representative Circuit Schematic (Each Amplifier)

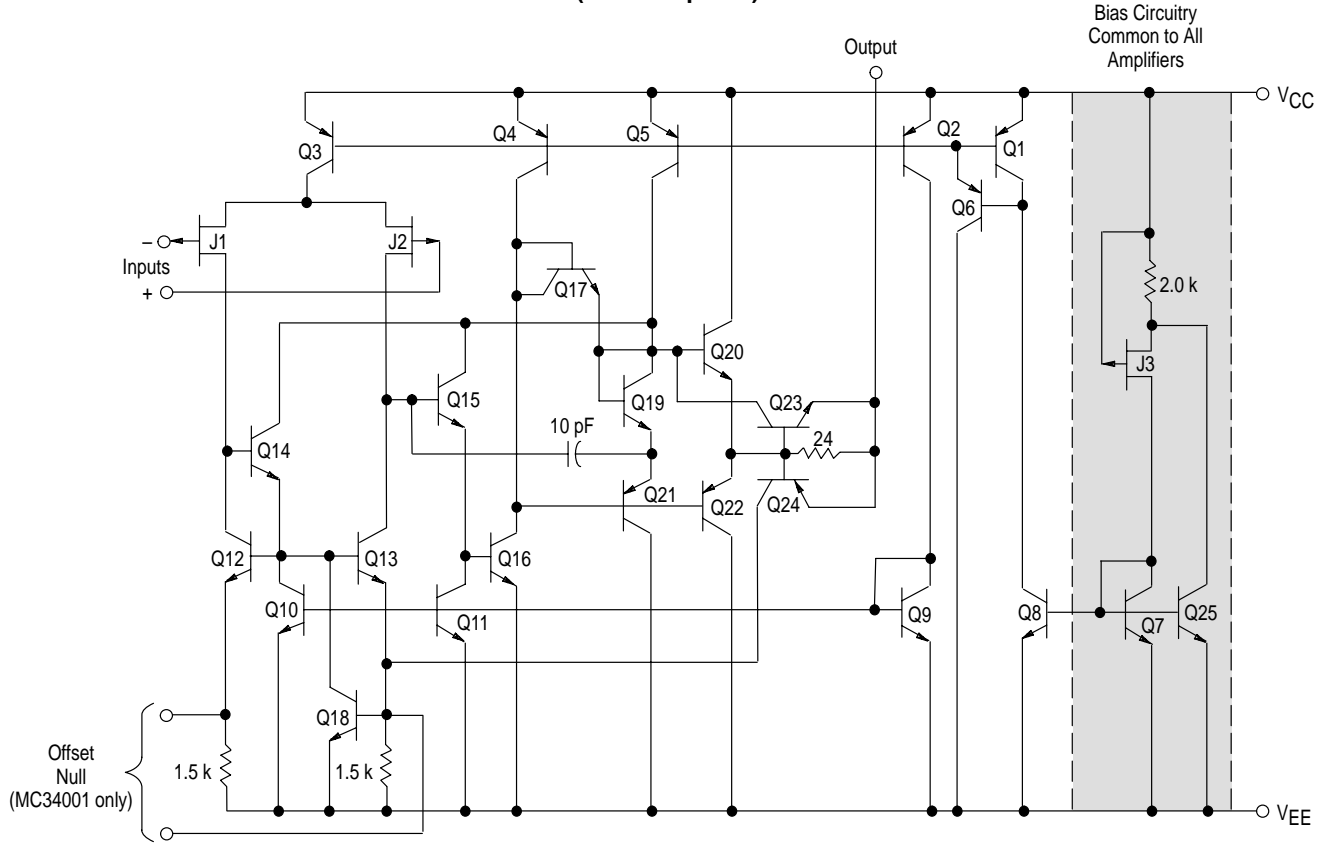
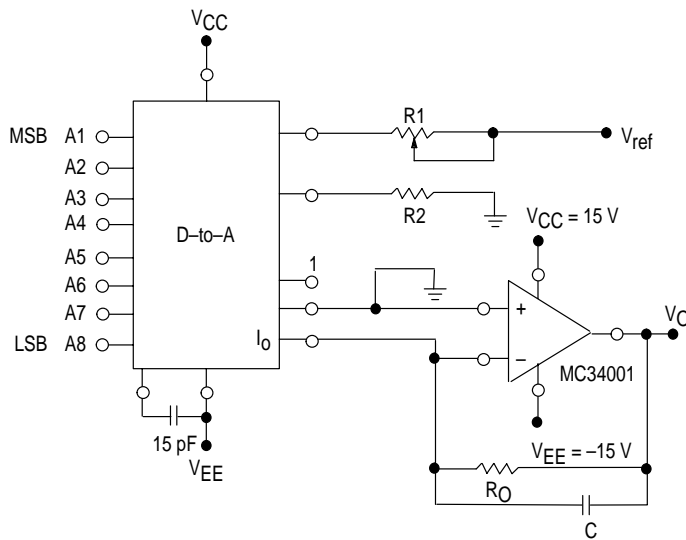

Figure 12. Output Current to Voltage Transformation for a D-to-A Converter



Settling time to within 1/2 LSB is approximately 4.0 μ s from the time all bits are switched ($C = 68$ pF).

The value of C may be selected to minimize overshoot and ringing.

Theoretical V_O

$$V_O = \frac{V_{ref}}{R_1} (R_O) \left[\frac{A_1}{2} + \frac{A_2}{4} + \frac{A_3}{8} + \frac{A_4}{16} + \frac{A_5}{32} + \frac{A_6}{64} + \frac{A_7}{128} + \frac{A_8}{256} \right]$$

MC34001, B MC34002, B MC34004, B

Figure 13. Positive Peak Detector

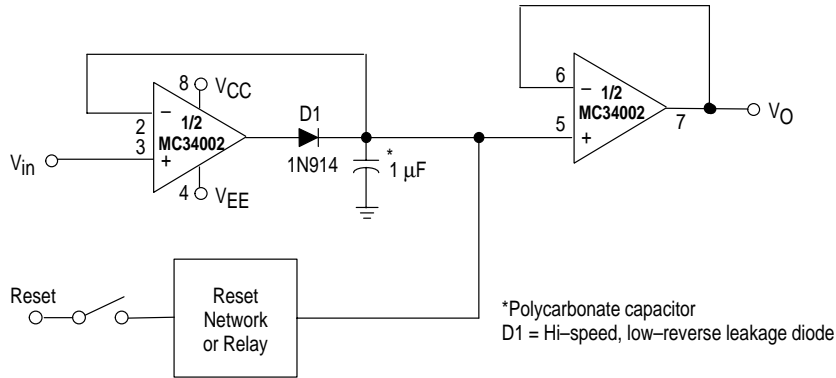
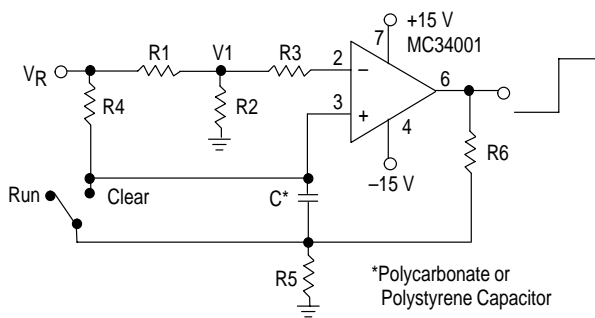

Figure 14. Long Interval RC Timer



$$\text{Time } (t) = R_4 C_n (V_R/V_R - V_i), R_3 = R_4, R_5 = 0.1 R_6$$

$$\text{If } R_1 = R_2: t = 0.693 R_4 C$$

Design Example: 100 Second Timer
 $V_R = 10 \text{ V}$ $C = 1.0 \mu\text{F}$ $R_3 = R_4 = 144 \text{ M}$
 $R_6 = 20 \text{ k}$ $R_5 = 2.0 \text{ k}$ $R_1 = R_2 = 1.0 \text{ k}$

Figure 15. Isolating Large Capacitive Loads

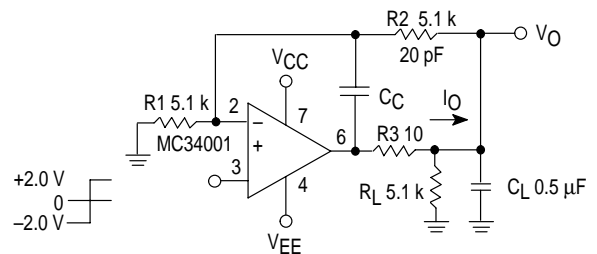

Overshoot < 10%
 $t_s = 10 \mu\text{s}$
 When driving large C_L , the V_O slew rate is determined by C_L and $I_{O(\text{max})}$:

$$\frac{\Delta V_O}{\Delta t} = \frac{I_O}{C_L} = \frac{0.02}{0.5} \text{ V}/\mu\text{s} = 0.04 \text{ V}/\mu\text{s} \text{ (with } C_L \text{ shown)}$$

Figure 16. Wide BW, Low Noise, Low Drift Amplifier

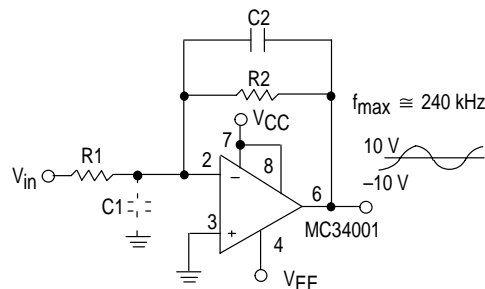

$$\text{Power BW: } f_{\text{max}} = \frac{S_r}{2\pi V_p} \approx 240 \text{ kHz}$$

Parasitic input capacitance ($C_1 \approx 3.0 \text{ pF}$ plus any additional layout capacitance) interacts with feedback elements and creates undesirable high-frequency pole. To compensate add C_2 such that: $R_2 C_2 \approx R_1 C_1$.

MC34001, B MC34002, B MC34004, B

OUTLINE DIMENSIONS

P SUFFIX
PLASTIC PACKAGE
CASE 626-05
ISSUE K

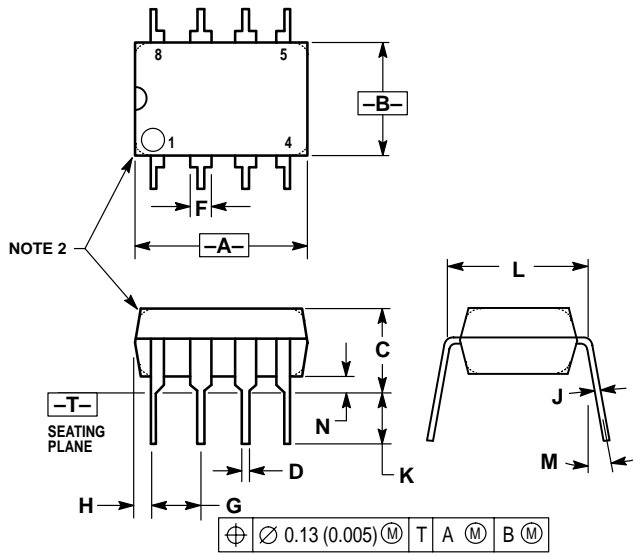

NOTES:

1. DIMENSION L TO CENTER OF LEAD WHEN FORMED PARALLEL.
2. PACKAGE CONTOUR OPTIONAL (ROUND OR SQUARE CORNERS).
3. DIMENSIONING AND TOLERANCING PER ANSI Y14.5M, 1982.

DIM	MILLIMETERS		INCHES	
	MIN	MAX	MIN	MAX
A	9.40	10.16	0.370	0.400
B	6.10	6.60	0.240	0.260
C	3.94	4.45	0.155	0.175
D	0.38	0.51	0.015	0.020
F	1.02	1.78	0.040	0.070
G	2.54 BSC		0.100 BSC	
H	0.76	1.27	0.030	0.050
J	0.20	0.30	0.008	0.012
K	2.92	3.43	0.115	0.135
L	7.62 BSC		0.300 BSC	
M	—		10°	
N	0.76	1.01	0.030	0.040

D SUFFIX
PLASTIC PACKAGE
CASE 751-05
(SO-8)
ISSUE R

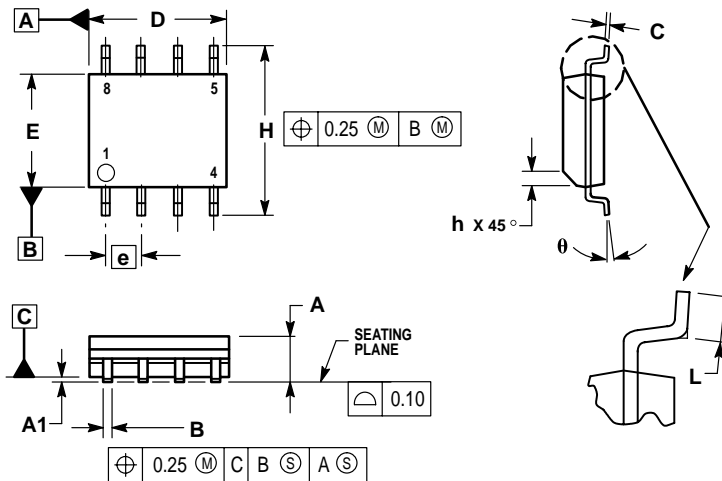

NOTES:

1. DIMENSIONING AND TOLERANCING PER ASME Y14.5M, 1994.
2. DIMENSIONS ARE IN MILLIMETERS.
3. DIMENSION D AND E DO NOT INCLUDE MOLD PROTRUSION.
4. MAXIMUM MOLD PROTRUSION 0.15 PER SIDE.
5. DIMENSION B DOES NOT INCLUDE MOLD PROTRUSION. ALLOWABLE DAMBAR PROTRUSION SHALL BE 0.127 TOTAL IN EXCESS OF THE B DIMENSION AT MAXIMUM MATERIAL CONDITION.

DIM	MILLIMETERS	
	MIN	MAX
A	1.35	1.75
A1	0.10	0.25
B	0.35	0.49
C	0.18	0.25
D	4.80	5.00
E	3.80	4.00
e	1.27 BSC	
H	5.80	6.20
h	0.25	0.50
L	0.40	1.25
θ	0° 7°	

MC34001, B MC34002, B MC34004, B

OUTLINE DIMENSIONS

P SUFFIX
PLASTIC PACKAGE
 CASE 646-06
 ISSUE L

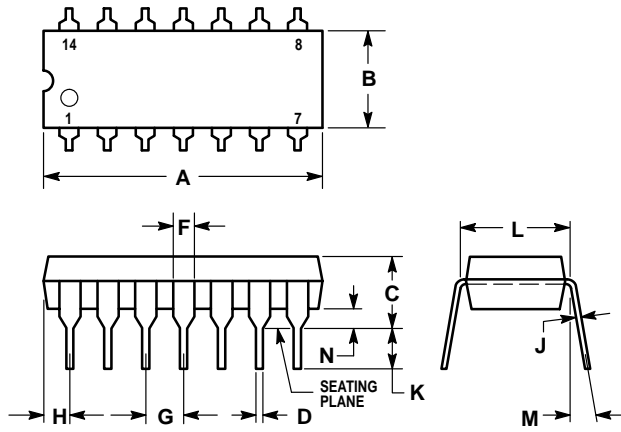

NOTES:

- LEADS WITHIN 0.13 (0.005) RADIUS OF TRUE POSITION AT SEATING PLANE AT MAXIMUM MATERIAL CONDITION.
- DIMENSION L TO CENTER OF LEADS WHEN FORMED PARALLEL.
- DIMENSION B DOES NOT INCLUDE MOLD FLASH.
- ROUNDED CORNERS OPTIONAL.

DIM	INCHES		MILLIMETERS	
	MIN	MAX	MIN	MAX
A	0.715	0.770	18.16	19.56
B	0.240	0.260	6.10	6.60
C	0.145	0.185	3.69	4.69
D	0.015	0.021	0.38	0.53
F	0.040	0.070	1.02	1.78
G	0.100 BSC		2.54 BSC	
H	0.052	0.095	1.32	2.41
J	0.008	0.015	0.20	0.38
K	0.115	0.135	2.92	3.43
L	0.300 BSC		7.62 BSC	
M	0° - 10°		0° - 10°	
N	0.015	0.039	0.39	1.01