

## Silicon Diffused Power Transistor

BU2515AF

## GENERAL DESCRIPTION

New generation, high-voltage, high-speed switching npn transistor in a plastic full-pack envelope intended for use in horizontal deflection circuits of pc monitors.

## QUICK REFERENCE DATA

SYMBOL	PARAMETER	CONDITIONS	TYP.	MAX.	UNIT
$V_{CESM}$	Collector-emitter voltage peak value	$V_{BE} = 0$ V	-	1500	V
$V_{CEO}$	Collector-emitter voltage (open base)		-	800	V
$I_C$	Collector current (DC)		-	9	A
$I_{CM}$	Collector current peak value		-	20	A
$P_{tot}$	Total power dissipation	$T_{hs} \leq 25$ °C	-	45	W
$V_{CEsat}$	Collector-emitter saturation voltage	$I_C = 4.5$ A; $I_B = 0.9$ A	-	5.0	V
$I_{Csat}$	Collector saturation current	$f = 56$ kHz	4.5	-	A
$t_f$	Fall time	$I_{Csat} = 4.5$ A; $f = 56$ kHz	0.2	0.4	$\mu$ s

## PINNING - SOT199

PIN	DESCRIPTION
1	base
2	collector
3	emitter
case	isolated

## PIN CONFIGURATION

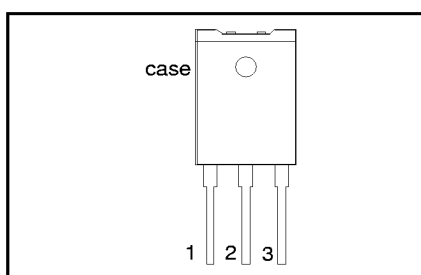

## SYMBOL

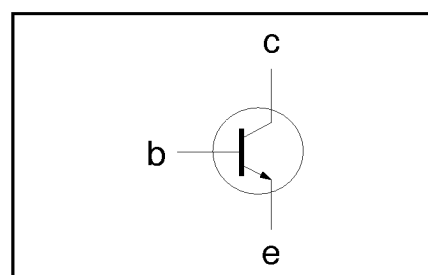

## LIMITING VALUES

Limiting values in accordance with the Absolute Maximum Rating System (IEC 134)

SYMBOL	PARAMETER	CONDITIONS	MIN.	MAX.	UNIT
$V_{CESM}$	Collector-emitter voltage peak value	$V_{BE} = 0$ V	-	1500	V
$V_{CEO}$	Collector-emitter voltage (open base)		-	800	V
$I_C$	Collector current (DC)		-	9	A
$I_{CM}$	Collector current peak value		-	20	A
$I_B$	Base current (DC)		-	5	A
$I_{BM}$	Base current peak value		-	7.5	A
$-I_{B(AV)}$	Reverse base current	average over any 20 ms period	-	125	mA
$-I_{BM}$	Reverse base current peak value <sup>1</sup>		-	6	A
$P_{tot}$	Total power dissipation	$T_{hs} \leq 25$ °C	-	45	W
$T_{stg}$	Storage temperature		-55	150	°C
$T_j$	Junction temperature		-	150	°C

## THERMAL RESISTANCES

SYMBOL	PARAMETER	CONDITIONS	TYP.	MAX.	UNIT
$R_{th\ j-hs}$	Junction to heatsink	with heatsink compound	-	2.8	K/W
$R_{th\ j-a}$	Junction to ambient	in free air	35	-	K/W

<sup>1</sup> Turn-off current.

Silicon Diffused Power Transistor

BU2515AF

**ISOLATION LIMITING VALUE & CHARACTERISTIC**

$T_{hs} = 25\text{ }^\circ\text{C}$  unless otherwise specified

SYMBOL	PARAMETER	CONDITIONS	MIN.	TYP.	MAX.	UNIT
$V_{isol}$	Repetitive peak voltage from all three terminals to external heatsink	R.H. $\leq 65\%$ ; clean and dustfree	-		2500	V
$C_{isol}$	Capacitance from T2 to external heatsink	$f = 1\text{ MHz}$	-	22	-	pF

**STATIC CHARACTERISTICS**

$T_{hs} = 25\text{ }^\circ\text{C}$  unless otherwise specified

SYMBOL	PARAMETER	CONDITIONS	MIN.	TYP.	MAX.	UNIT
$I_{CES}$	Collector cut-off current <sup>2</sup>	$V_{BE} = 0\text{ V}; V_{CE} = V_{CESMmax}$	-	-	1.0	mA
$I_{CES}$		$V_{BE} = 0\text{ V}; V_{CE} = V_{CESMmax}; T_j = 125\text{ }^\circ\text{C}$	-	-	2.0	mA
$I_{EBO}$	Emitter cut-off current	$V_{EB} = 7.5\text{ V}; I_C = 0\text{ A}$	-	-	1.0	mA
$BV_{EBO}$	Emitter-base breakdown voltage	$I_B = 1\text{ mA}$	7.5	13.5	-	V
$V_{CEsat}$	Collector-emitter saturation voltage	$I_C = 4.5\text{ A}; I_B = 0.9\text{ A}$	-	-	5.0	V
$V_{BEsat}$	Base-emitter saturation voltage	$I_C = 4.5\text{ A}; I_B = 0.9\text{ A}$	-	-	1.0	V
$h_{FE}$	DC current gain	$I_C = 500\text{ mA}; V_{CE} = 5\text{ V}$	-	17.2	-	
$h_{FE}$		$I_C = 4.5\text{ A}; V_{CE} = 5\text{ V}$	5	8.2	10.8	

**DYNAMIC CHARACTERISTICS**

$T_{hs} = 25\text{ }^\circ\text{C}$  unless otherwise specified

SYMBOL	PARAMETER	CONDITIONS	TYP.	MAX.	UNIT
	Switching times (56 kHz line deflection circuit)	$I_{Csat} = 4.5\text{ A}; L_C = 250\text{ }\mu\text{H}; C_{fb} = 4\text{ nF}; I_{B(end)} = 0.65\text{ A}; L_B = 1.5\text{ }\mu\text{H}; -V_{BB} = -4\text{ V}; -I_{BM} = 2.7\text{ A}$			
$t_s$	Turn-off storage time		2.2	3.0	$\mu\text{s}$
$t_f$	Turn-off fall time		0.2	0.4	$\mu\text{s}$

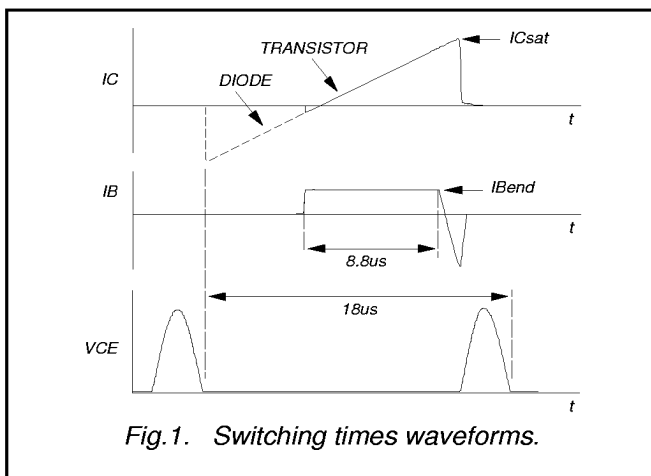

Fig.1. Switching times waveforms.

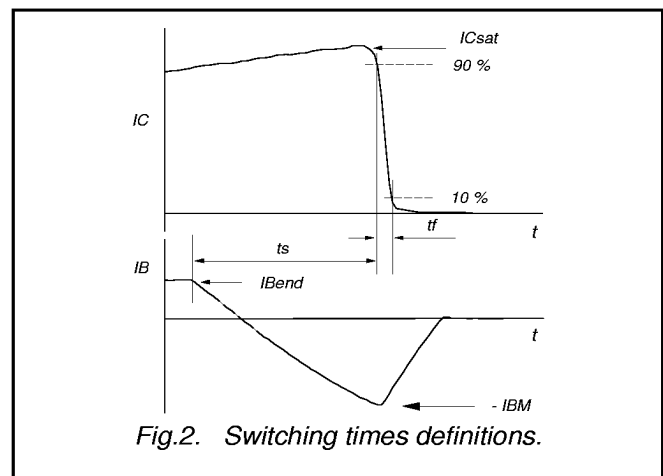
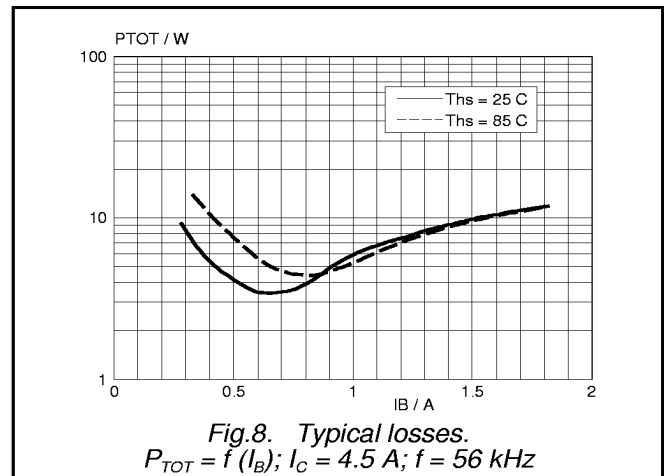
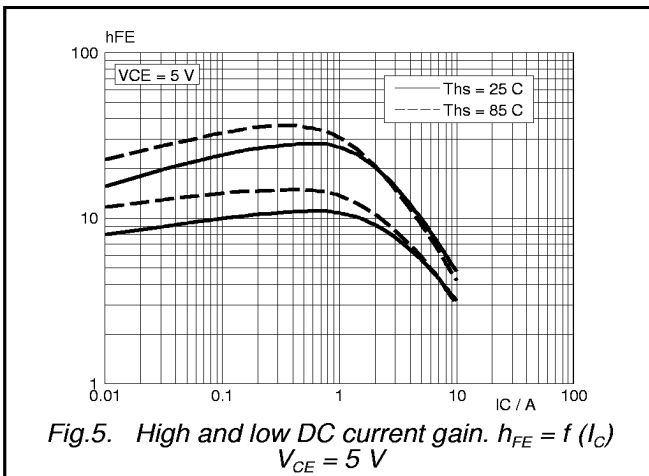
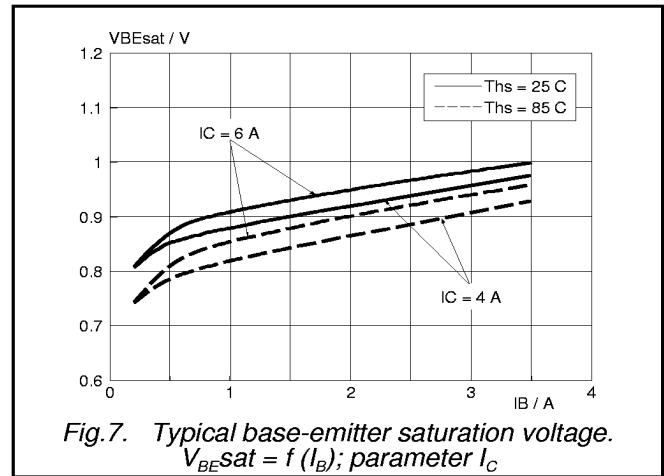
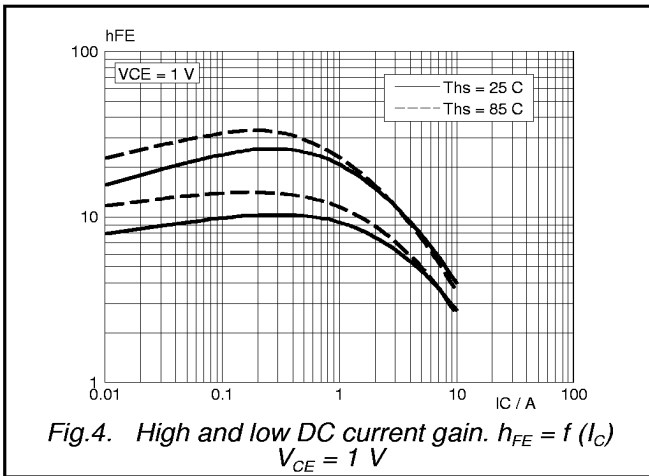
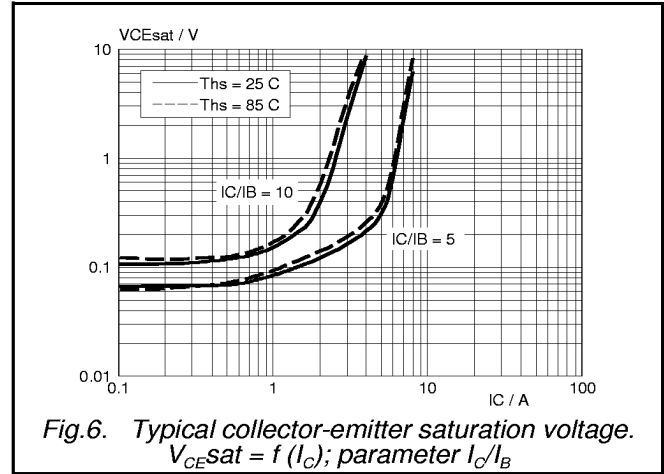
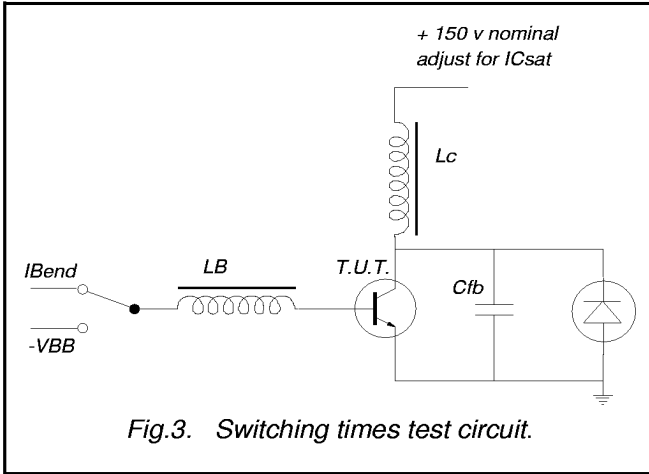

Fig.2. Switching times definitions.

<sup>2</sup> Measured with half sine-wave voltage (curve tracer).

Silicon Diffused Power Transistor

BU2515AF



Silicon Diffused Power Transistor

BU2515AF

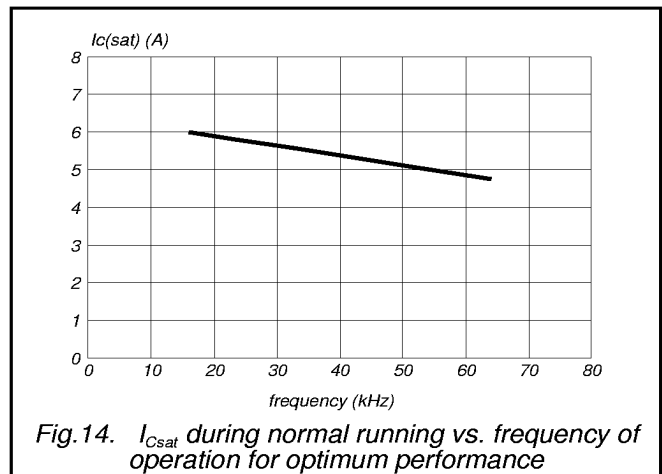
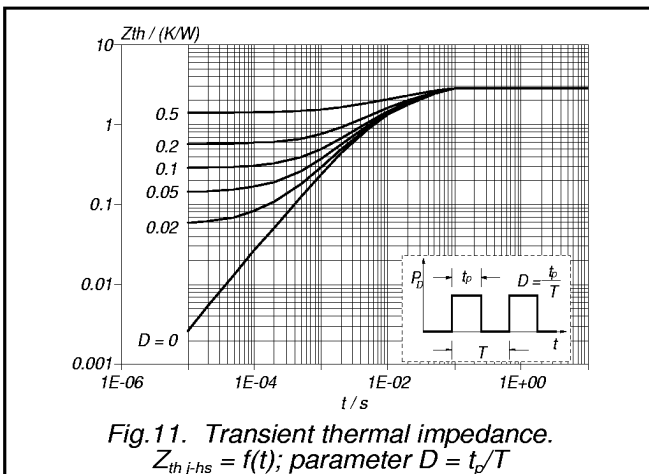
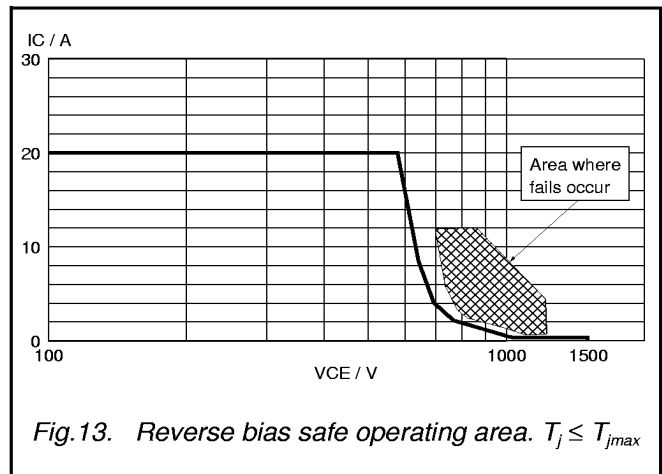
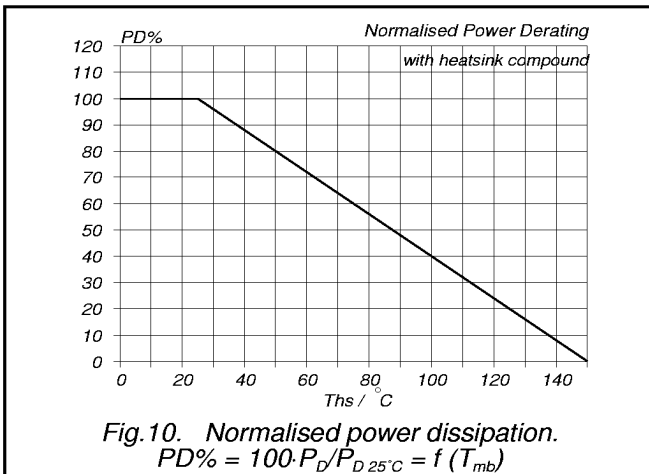
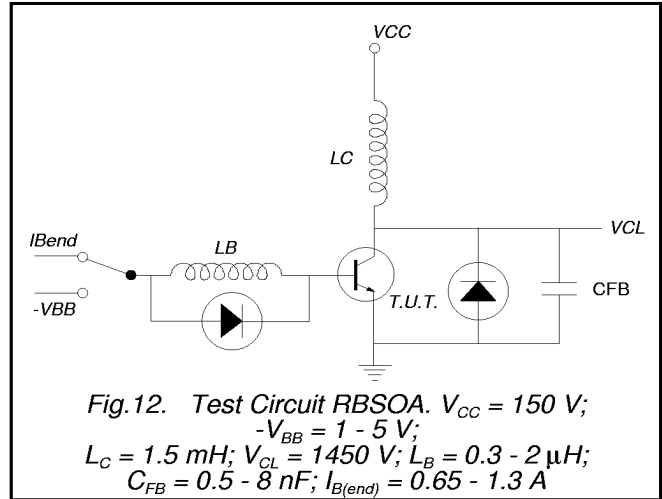
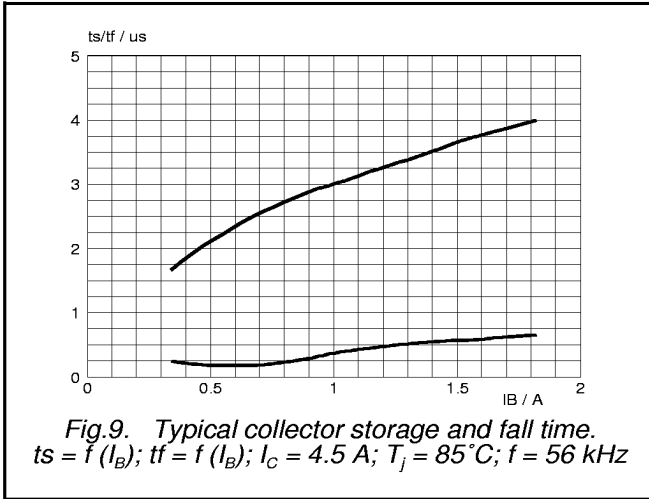

Silicon Diffused Power Transistor

BU2515AF

**MECHANICAL DATA**

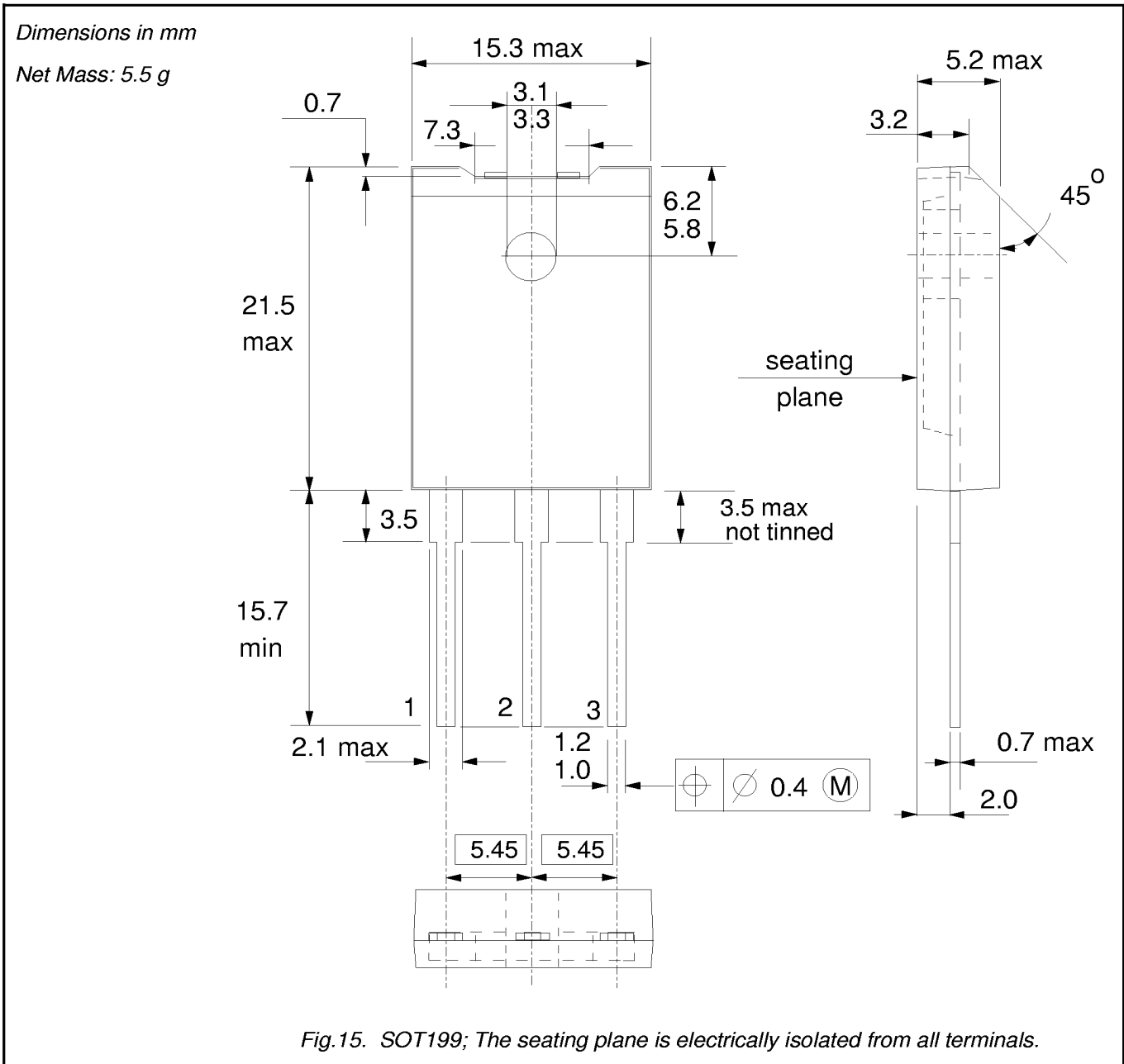

**Notes**

1. Refer to mounting instructions for F-pack envelopes.
2. Epoxy meets UL94 V0 at 1/8".