

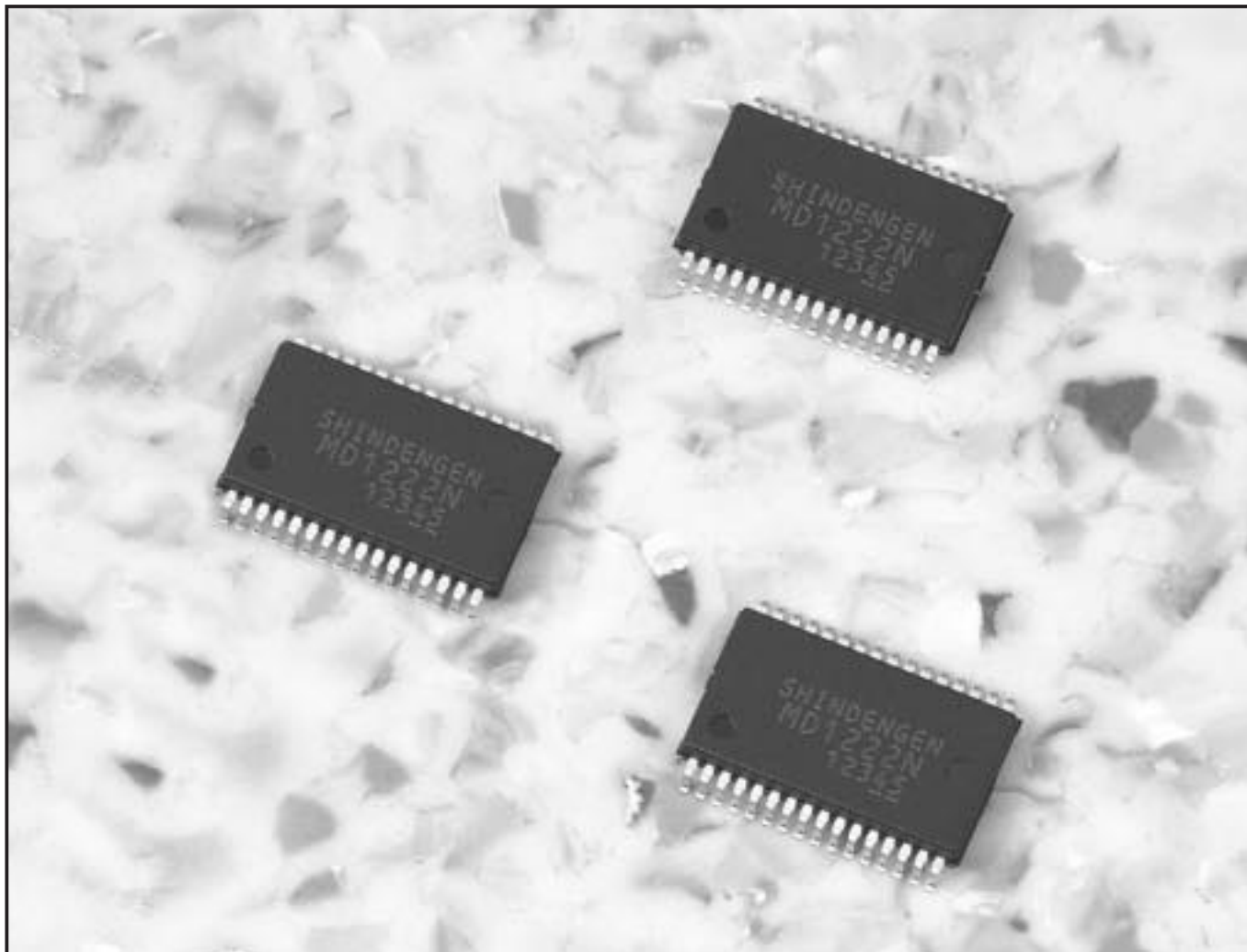

5A Synchronous Rectification System
Variable Output Voltage Stepdown
DC to DC Converter Power IC
MD1222N
Application Manual



SHINDENGEN ELECTRIC MFG. CO., LTD.

1 Using the MD1222N DC to DC Converter Power IC

Thank you for purchasing the MD1222N DC to DC Converter Power IC. This manual contains important information on the safe use of the MD1222N. Your safety is most important to our company. Please read these instructions carefully before using this device.

CAUTION



The improper use of this device can result in serious injury or death. Expensive damage to this and other equipment can result. Failure to observe the cautions in this Manual can also result in minor injuries and annoying equipment damage.

CAUTION



The MD1222N is intended for use with general electronic equipment (office automation, communication, measurement, household, etc.) It is not intended for use with equipment whose failure might result in the death or injury of those depending upon it (medical treatment, air navigation, railroad, cargo handling, nuclear power, etc.)

If you intend to use the MD1222N with other than the general equipment listed above, please consult with our company.



Under no conditions attempt to repair or modify this device by yourself. Doing so can result in electric shock, equipment breakage, fire, and unreliable (and dangerous) equipment operation.



Abnormal operating conditions may result in excessive voltage at the output terminal or excessive voltage drops elsewhere in the device. Take steps to prevent load mishandling and breakage (overvoltage and overcurrent prevention) at the final point in the equipment chain.



Overvoltage protection

The MD1222N is not equipped with an overvoltage protection function. In the event excessive voltage appears within a module, the high input voltage may remain together with a high output voltage even when the equipment is turned off. Smoke and flame may appear. To prevent this, be sure to install some sort of overvoltage protection circuitry before using the equipment.



Before providing electrical power to the device, check that the polarity of the input and output terminals is correct (check for misconnections). If circuit protection circuitry is cut off from the rest of the equipment, smoke and flames may appear.



Be sure that input voltage level is maintained at the specified level. This may require the installation of a voltage regulator to the input line. Voltage fluctuations may result in the appearance of smoke and flames.



If a breakdown or other abnormal condition occurs during equipment use, immediately stop power to the equipment. Contact our company at your earliest possible convenience.

- The information appearing in this Manual is the latest available at the time of publication. We reserve the right to make changes to the device without prior notice. Therefore, your device may differ slightly from that described in this Manual.
- Every effort has been made to make the information in this Manual accurate and reliable. However, our company takes no responsibility for injuries or damage incurred when using the device as described in this Manual. Neither do we take responsibility for damages incurred as a result of patent or other defined rights.
- We do not give consent for a third person to use our patent or other rights based on this material. We do not guarantee these rights.
- No part of this material may be reproduced or copied without the specific written consent of our company.
- This device fully meets the reliability and quality control standards described in our company's catalog. If this device is to be used in a situation where its misuse or failure might cause serious injury or death, consult with our company.
- Reliability and quality control standards for this device are considered adequate when it is used with the following types of end equipment. Computer - Office automation - Communication terminal - Measurement - Machine tools - Audio-visual - Games and other amusements - Household appliance - Personal items - Industrial robot.
Special applications where the device may or may not be suitable include the following.
Transportation and conveyance (cargo loading) equipment- Primary communications equipment- Traffic signal control equipment - Fire and burglary alarms - Various safety devices - Medical equipment
Other special applications where the device reliability is not considered high enough include the following.
Atomic energy control systems - Aviation equipment- Aeronautics and space equipment - Ocean depth sounding equipment - Life support equipment
- Our company makes a constant effort to improve the quality and reliability of our products. However, it is the customer's responsibility to provide safety. Take the appropriate steps to prevent personal injury, fire, and damage by providing redundancy equipment, fire containment equipment, and devices to protect personnel and equipment from operational mistakes.

DC to DC Converter Power IC MD1222N Application Manual Table of Contents

CONTENTS

1 .	Using the MD1222N DC to DC Converter Power IC	1
2 .	General description of the DC to DC Converter Power IC MD1222N.....	3
2 – 1	Features	
2 – 2	Applications	
2 – 3	Nomenclature	
2 – 4	Peripheral functions	
2 – 5	Terminal functions	4
2 – 6	Block diagrams	5
3 .	External dimensions (Diagram)	6
4 .	Characteristics	7
5 .	Mounting	8
5 – 1	Soldering pattern reference (Reflow-type)	
5 – 2	Mounting cautions	
5 – 3	Printed circuit board patterns and design considerations (Reference) ...	9
6 .	Operating instructions	10,11
6 – 1	For use with output voltage lower than 5.3V	
6 – 2	For use with output voltage higher than 5.3V	12,13
6 – 3	Remote ON/OFF Control Function	14
6 – 4	Input protection element connection	15
6 – 5	Overvoltage protection	
7 .	Basic design procedure	17
7 – 1	Overcurrent detecting resistor (R2) selection	
7 – 2	Inductance (L1) selection	
7 – 3	Output capacitor selection	18
7 – 4	Input capacitor selection	
7 – 5	Thermal management	
8 .	Electrical measurement data	19~28
8 – 1	Output voltage - 2.5V	
8 – 2	Output voltage - 3.3V	
8 – 3	Output voltage - 5V	
8 – 4	Output voltage - 9V	
8 – 5	Output voltage - 12V	
9 .	Packing conditions	29
9 – 1	Taping type	
9 – 2	Package configuration	
9 – 3	Order quantity and dimensions	

2 General description of the DC to DC Converter Power IC MD1222N

The MD1222N is a non-isolated step-down DC to DC converter power IC. Main components are the MOSFET switch and the built-in synchronous rectification MOSFET. Maximum output is 5A. The equipment is highly efficient and may be used for a wide range of applications.

Output voltage is further adjustable using external resistances (2.5V - 12V).

HSOP-type surface mount packaging is used. Minimal external control circuitry is required. This permits a small footprint and low profile of power supply.

◆ 2 – 1 Features

- Input voltage range: 8~20V
- Output voltage : Output voltage Adjustable using external resistances (2.5V - 12V)
- Maximum output current: 5A (Derating is required for output higher than 5.3V).
- Main switch MOSFET and built-in synchronous rectification MOSFET
- Oscillation frequency: 250 kHz (Built-in oscillator does not require external capacitors or resistors)
- Overcurrent protection function
- Heat protection function
- Built-in low-voltage protection (UVLO) function
- Built-in remote control functions

◆ 2 – 2 Applications

- Information distribution equipment
- Office automation equipment
- Electronic measuring instruments
- Home appliances
- Telecommunications equipment
- Factory automation equipment (Process control)
- Audio-video devices

◆ 2 – 3 Nomenclature

Device name and packaging specification codes are provided. Shipping conditions are determined according to these specifications.

Entry example: MD1222N 4072

Specification code: Shows package configuration and product name

◆ 2 – 4 Peripheral functions

1) Internal reference voltage (Vref)

IC internal circuitry reference voltage is provided by the temperature compensation reference voltage (5.0V). This reference voltage (Vref) provides a maximum external output current measured at the terminal of 1 mA.

2) Oscillation circuit (OSC)

The oscillation circuit is built into the device. No external oscillation capacitor nor resistor is required. The oscillation frequency (250 kHz) is set internally and has a sawtooth wave pattern. The sawtooth wave pattern cannot be outputted externally.

3) Error amplifier (Error Amp.)

The error amplifier senses the DC to DC converter voltage and provides a PWM control signal output. Loop gain between the error amplifier ampOUT terminal and the negative amp terminal is determined by the connections between the feedback resistor and the capacitor. This provides stable loop compensation throughout the system.

4) Overcurrent sensor (OCL)

The OCL is a pulse-by-pulse overcurrent sensor. The voltage drop across the external current sensing resistor is measured between the negative and positive terminals of the OCL. If the voltage drop exceeds $\approx 0.19V$, the main switch (MOSFET) opens.

◆ 2 – 5 Terminal functions

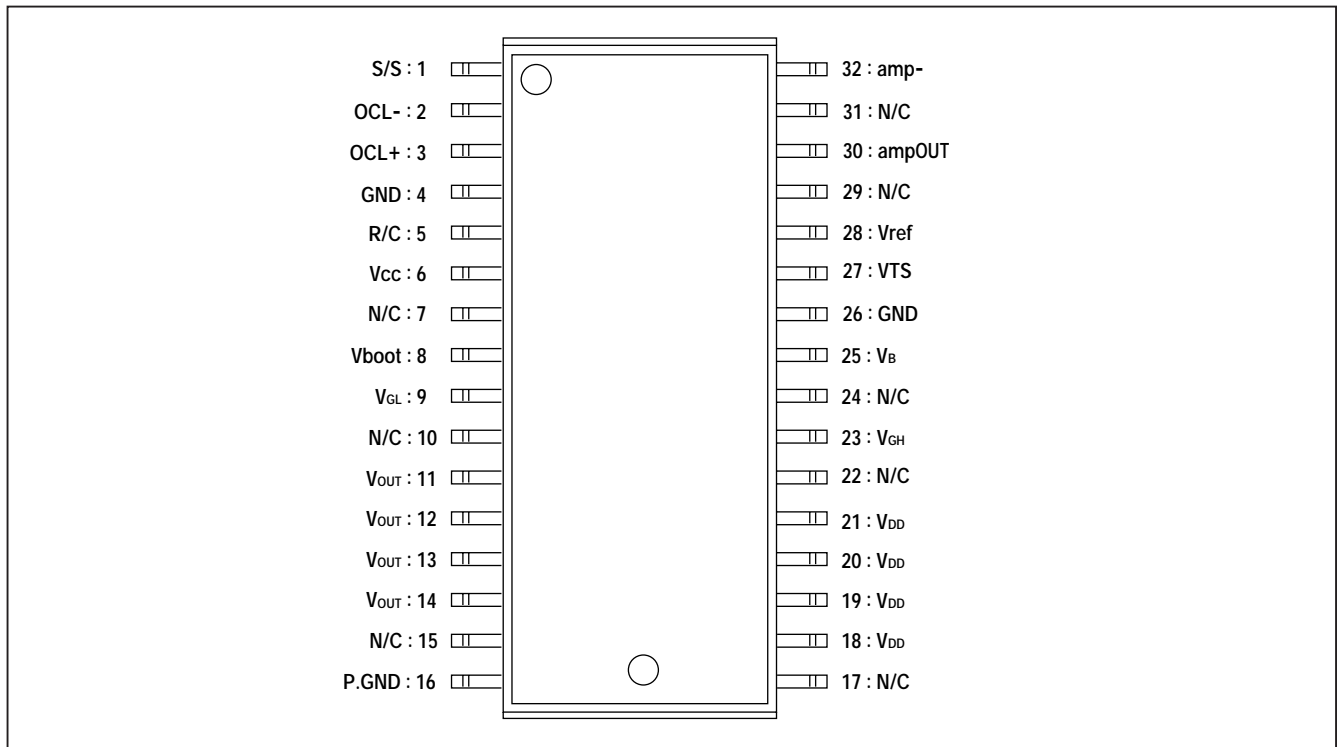

Terminal No.	Terminal symbol	Function
1	S/S	Soft-start capacitor terminal
2	OCL-	Overcurrent detection terminal (-)
3	OCL+	Overcurrent detection terminal (+)
4,26	GND	Ground terminal
5	R/C	Remote ON/OFF control terminal
6	Vcc	Control circuit power supply terminal
8	Vboot	Main switch MOSFET control circuit power supply terminal
9	VGL	Low side MOSFET gate terminal for synchronous rectification
11~14	VOUT	Power supply output terminal
16	P.GND	Output circuit ground terminal
18~21	VDD	Main switch MOSFET power supply terminal
23	VGH	Main switch high side MOSFET gate terminal
25	VB	Output boot strap terminal. Used for connecting condenser across VB and VOUT terminals to boot strap IC internal main switch MOSFET control circuit.
27	VTS	Test terminal. Do not connect it to anything.
28	Vref	Internal reference voltage output terminal
30	ampOUT	Internal error amplifier output terminal
32	amp-	Internal error amplifier reversing input terminal
7,10,15,17,22, 24,29,31	N/C	No connection terminal (N/C terminal)

◆ 2 – 6 Block diagrams

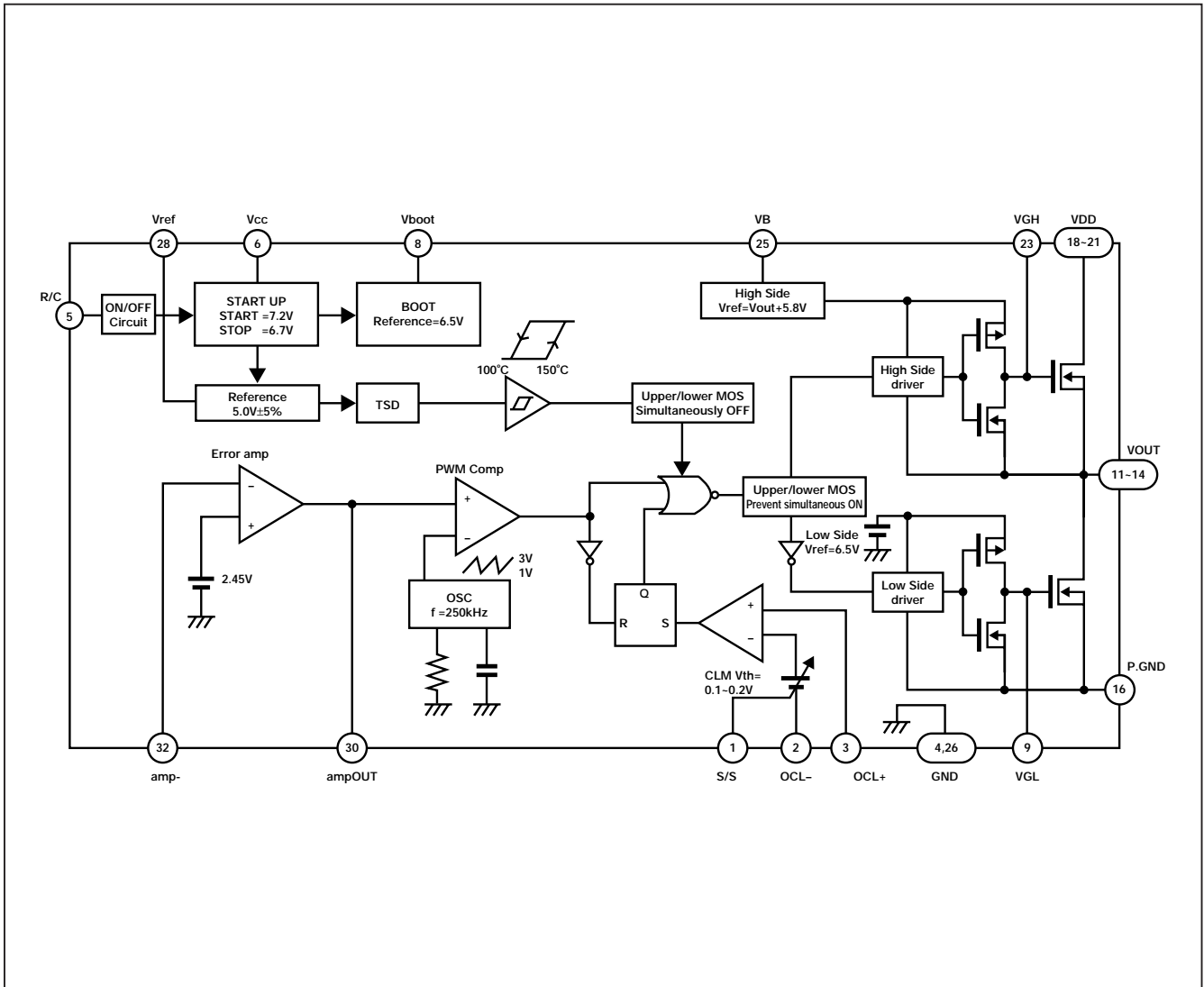

3 External dimensions (Diagram)(SSOP-32)

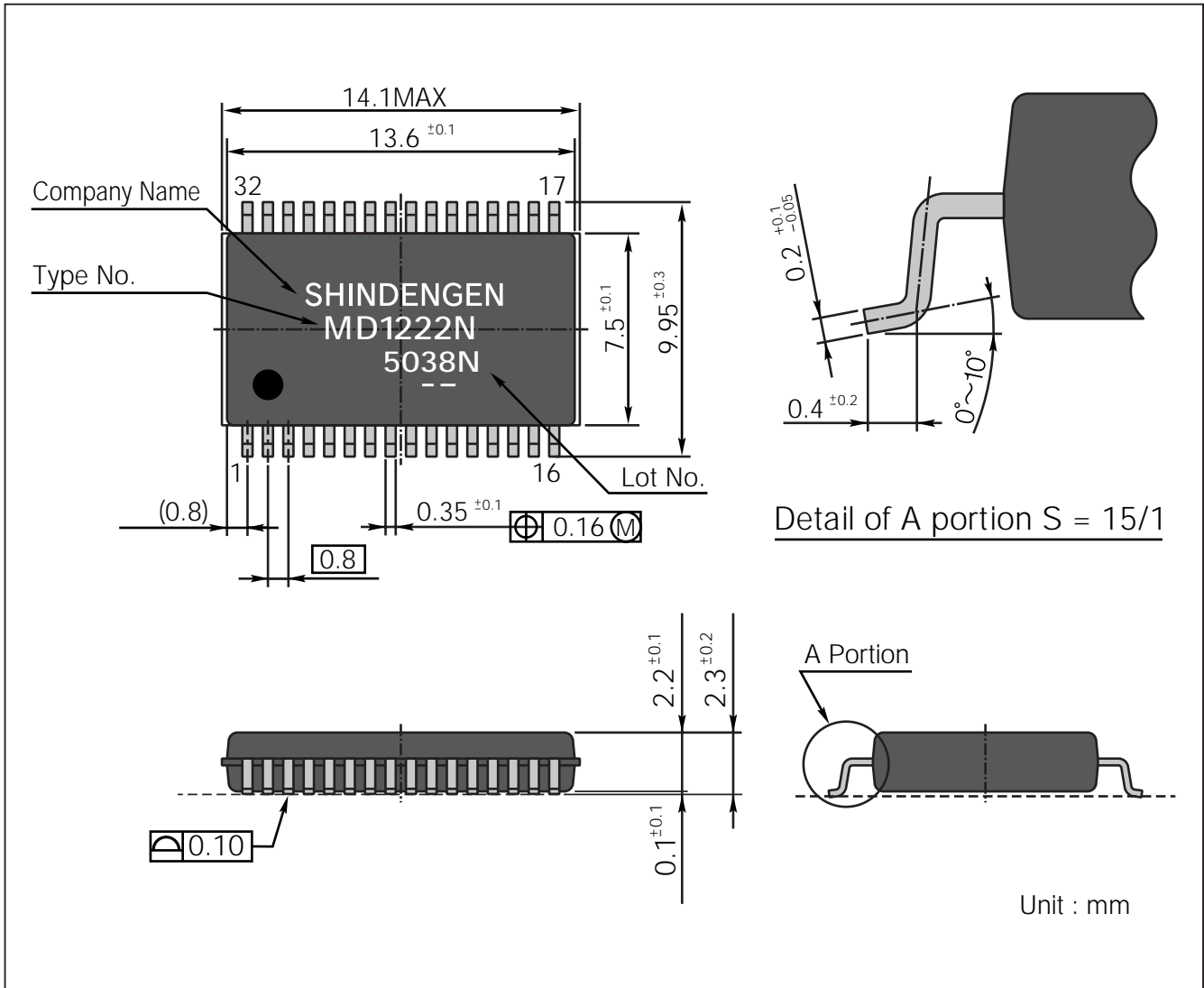

4 Characteristics

1) Absolute maximum rating (Ta=25 C)

Item	Symbol	Rating	Unit
Line voltage	V _{IN}	22	V
Output MOS input voltage	V _{DD}	22	V
Output current (AVE)	I _{OUTAVE}	5	A
Output current (PEAK)	I _{OUTPEAK}	6	A
OCL-, OCL+ terminal voltage	V _{OCL}	5.5	V
Remote control voltage	V _{RC}	5.5	V
Storage temperature	T _{stg}	-40~150	°C
Junction temperature	T _j	150	°C

2) Recommended operating conditions

Item	Recommended value	Unit
Input voltage	8~20	V
Output voltage setting range	2.5~12	V
Operating temperature	-10~80	°C

4) Output current deleting for output higher than 5.3V

Set output voltage	Output current
2.5V~5.3V	5A
≤ 8V	3A
≤ 12V	2.5A

3) Electrical characteristics (Ta=25 C)

Item	Symbol	Conditions	MIN	TYP	MAX	Unit
HighsideMOS Drain-source breakdown voltage	V _{dss}	I _D = 1mA, V _{GS} = 0V	22	-	-	V
HighsideMOS Drain interruption current	I _{dss}	V _{DS} = 20V, V _{GS} = 0V	-	-	10	μA
HighsideMOS Drain-source ON resistance	R _{on}	I _D = 1.2A, V _{GS} = 4.5V	-	22	55	mΩ
HighsideMOS Source-drain Di forward voltage	V _{SD}	I _S = 1.2A, V _{GS} = 0V	-	-	1.5	V
LowSideMOS Drain-source breakdown voltage	V _{dss}	I _D = 1mA, V _{GS} = 0V	22	-	-	V
LowSideMOS Drain interruption current	I _{dss}	V _{DS} = 20V, V _{GS} = 0V	-	-	10	μA
LowSideMOS Drain-source ON resistance	R _{on}	I _D = 1.2A, V _{GS} = 4.5V	-	22	55	mΩ
LowSideMOS Source-drain breakdown voltage	V _{SD}	I _S = 1.2A, V _{GS} = 0V	-	-	1.5	V
Start voltage	V _{cc_start}	-	6.5	7.2	7.9	V
Stop voltage	V _{cc_stop}	-	6.0	6.7	7.4	V
Start-stop voltage hysteresis	V _{cc_hys}	-	-	0.5	-	V
Current consumption	I _{cc}	V _{cc} = 8V~20V	-	10	13	mA
Current consumption with remote control OFF	I _{cc_off}	V _{cc} = 8V~20V	-	1.2	1.5	mA
Voltage with remote control terminal ON	V _{RC_on}	V _{cc} = 8V~20V	-0.2	-	0.5	V
Voltage with remote control terminal OFF	V _{RC_off}	V _{cc} = 8V~20V	2.5	-	5.3	V
Current with remote control terminals shorted	I _{RC}	V _{cc} = 8V~20V	-	-	250	μA
BOOT terminal voltage	V _{boot}	V _{cc} = 12V	5.4	6.5	7.6	V
Internal reference voltage	V _{ref}	V _{cc} = 8V~20V	4.75	5	5.25	V
Internal oscillation frequency	f _{osc}	V _{cc} = 12V	212.5	250	287.5	kHz
Overcurrent threshold voltage	V _{th_OCL}	V _{cc} = 12V	0.162	0.19	0.218	V
SoftStart terminal current	I _{s/s}	V _{cc} = 12V	-20	-12.5	-5	μA
ErrorAmp reference voltage	V _{vamp}	V _{cc} = 8V~20V	2.4	2.45	2.5	V
Overcurrent protection operating temperature	T _{TSD}	-	-	150	-	°C

5 Mounting

◆ 5 – 1 Soldering pattern reference (Reflow-type)

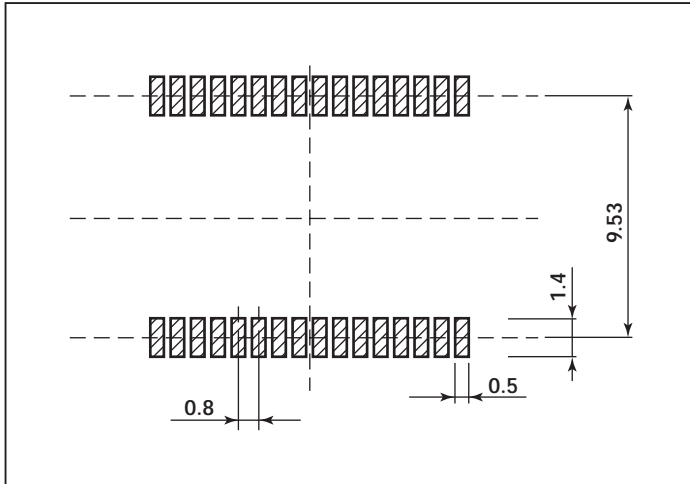

◆ 5 – 2 Mounting cautions

1) Mounting

Vibration and other mechanical disturbances can exert stress on the internal parts of the device. Carefully examine your equipment and place the device where vibration and other shock is minimal.

2) Soldering cautions

● Infrared reflow method

This method provides very high temperature soldering. The chart at the right shows the recommended temperature profiles for the Infrared reflow soldering method.

● Soldering iron

When using a soldering iron, observe the following.

Soldering iron temperature: Not to exceed 300°C

Soldering iron contact time: Not to exceed 5 seconds

3) Cleaning cautions

Carefully remove all flux. Allow time for the soldered areas to completely dry before using the device.

4) Secondary mold cautions

After installation of the device to a board, remolding using plastic may be required. During this process, stress on the device will depend on the type of plastic used. The best plastic (that which causes the least stress on the device) has a minimum contraction ratio and high flexibility. Hardening temperatures should not exceed the storage temperature. Carefully check the plastic characteristics before use.

- ※ Static electricity can damage the device. The person and clothing of personnel working with the device should be grounded to prevent the build-up of static electricity. It is recommended that personnel stand on rubber mats (electrical safety mats) having a resistance greater than 1MΩ when working with the device. This will prevent damage to the device from static electricity discharge and protect the personnel from electrical shock.

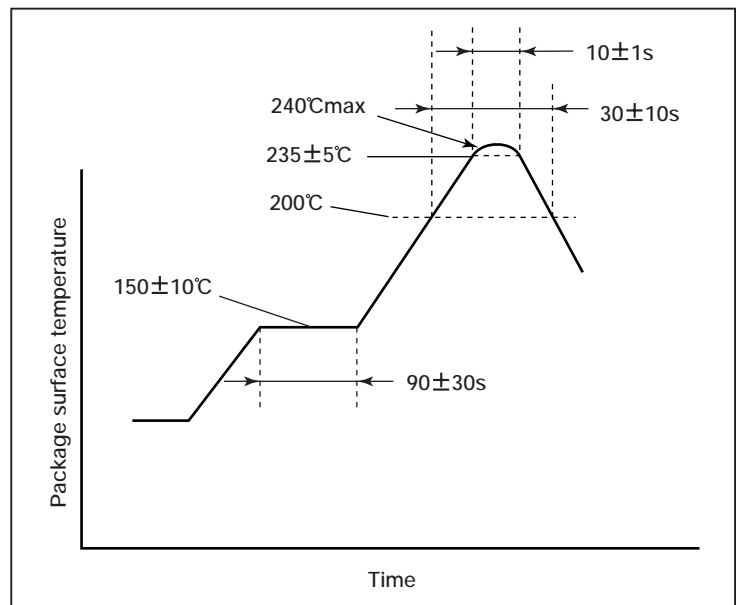

(Figure 5-A)

◆ 5 – 3 Printed circuit board patterns and design considerations(Reference)

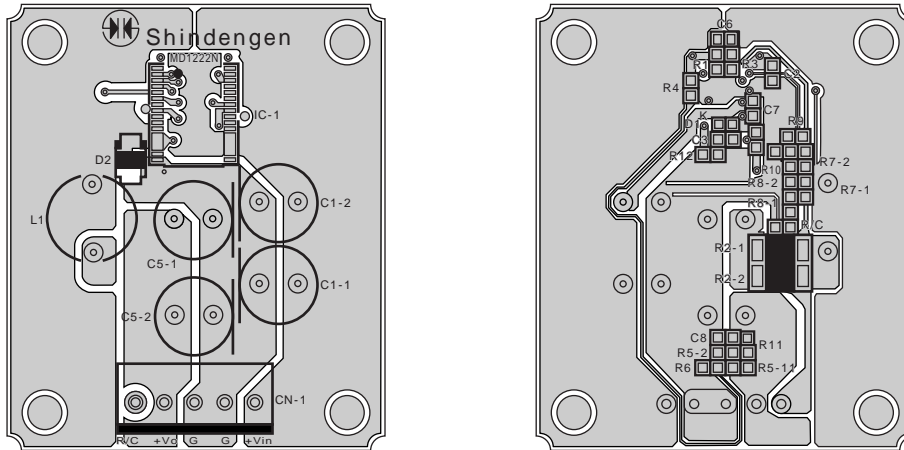

5A Product model sample

※ The device does not have a voltage surge protection circuit or an input fuse. The user should install an input fuse to protect the device and equipment before using the device.

- For optimum thermal efficiency, maintain the copper foil pattern as much as possible.
- Connect the input capacitor (C1), output capacitor (C5), choke (L1), and drooping resistor (R2) as close as possible to the power IC device.
- Separate the ground terminals (Pin 4 and Pin 26) and the P and ground terminals (Pins 16). Connect each of them as close as possible to output capacitor (C5).
- OCL + (3rd pin) and OCL - (2nd pin) should be connected as close to the drooping resistance (R2) as possible.
- Output detect resistances (R5, R6) should be connected as close to the load as possible.

6 Operating instructions

The MD1222N power IC device uses chopper circuitry and can be referred to as a chopper type DC to DC converter. The device requires an external choke and capacitor to be connected to it. The characteristics of these external parts and the way they are packaged and connected will greatly affect the performance of the device and its circuits. Carefully select these external parts to provide optimum device performance. Neither the device input side nor output side is isolated.

◆ 6 – 1 For use with output voltage lower than 5.3V

1) Basic input and output terminal connections

Power IC device connection and use involves the rated output voltage and the maximum current output range.

- Pins 9, 23 and 27 are the test terminals and must be left open.
- Pins 7, 10, 15, 17, 22, 24, 29 and 31 are internal non-connecting pins (N/C terminals).
- Figure 6-A shows the external parts and their connections. Be sure to prepare and connect these items before using the device.
- Output capacitor (C5) minimizes switching frequency ripple and provides a smooth and stable output voltage. The use of a low-impedance capacitor is recommended (low impedance provides minimum ripple).

● Standard connections (Figure 6-A)

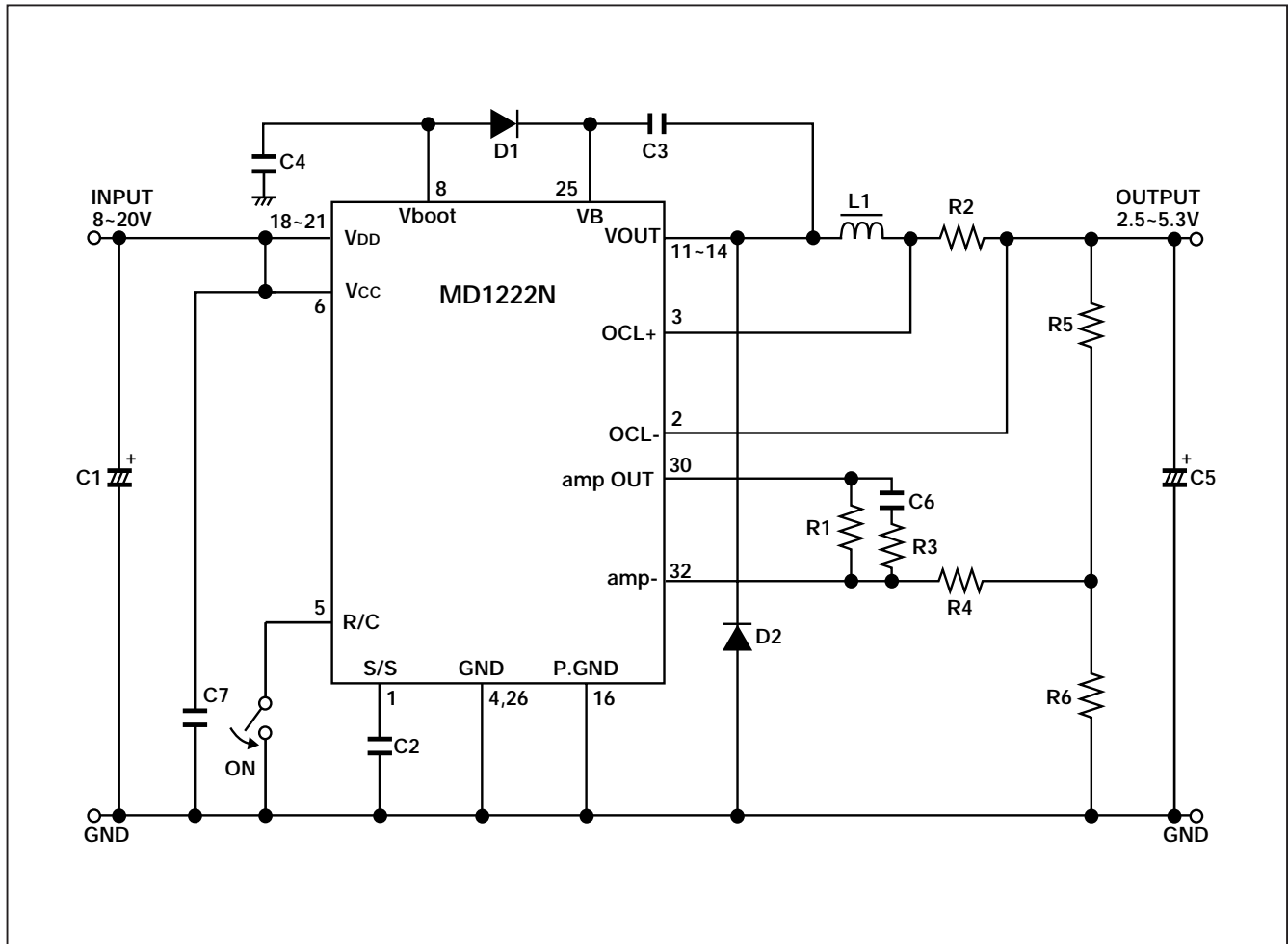

2) Resistors for setting output voltage

Output voltage is adjusted using R5 and R6.

$$R6 = 2.2k\Omega$$

$$R5 = \frac{R6 \times (V_{out} - 2.45)}{2.45} [\Omega]$$

3) Reference parts

Reference parts for the standard circuit

Part No.	Nomenclature	Output voltage 2.5V~5.3V		
		Output current example		
		3 A	4 A	5 A
L1	Choke	18μH 3A	15μH 4A	10μH 5A
D1	Diode	HSU119 (80V 0.3A)	HSU119 (80V 0.3A)	HSU119 (80V 0.3A)
D2	Shottky barrier diode	D1FS4A (40V 1.5A)	M2FM3 (30V 4.3A)	M2FM3 (30V 4.3A)
C1	Electrolyte capacitor (parallel)	25V 220μF 760mA×2	25V 330μF 1030mA×2	25V 470μF 1250mA×2
C2	Ceramic capacitor	25V 0.047μF	25V 0.047μF	25V 0.047μF
C3	Ceramic capacitor	25V 0.01μF	25V 0.01μF	25V 0.01μF
C4	Ceramic capacitor	25V 0.01μF	25V 0.01μF	25V 0.01μF
C5	Electrolyte capacitor (parallel)	10V 680μF 53mΩ×2	10V 1000μF 38mΩ×2	10V 1200μF 23mΩ×2
C6	Ceramic capacitor	25V 1000pF	25V 1000pF	25V 1000pF
C7	Ceramic capacitor	25V 0.1μF	25V 0.1μF	25V 0.1μF
R1	Resistance	0.1W 1MΩ	0.1W 1MΩ	0.1W 1MΩ
R2	Resistance (parallel)	0.75W 0.1Ω ±5%×2	0.75W 0.075Ω ±5%×2	1W 0.062Ω ±5%×2
R3	Resistance	0.1W 100kΩ	0.1W 100kΩ	0.1W 100kΩ
R4	Resistance	0.1W 10kΩ	0.1W 10kΩ	0.1W 10kΩ
R5	Resistance	It is determined using the expression in Item 6-1 (2).		
R6	Resistance	0.1W 2.2kΩ ±0.5%	0.1W 2.2kΩ ±0.5%	0.1W 2.2kΩ ±0.5%

4) Electrical characteristics (Ta=25°C)

Efficiency and ripple are measured according to external reference parts circuit configuration that is based on standard circuit configuration (Figure 6-A).

Item	Output current example								
	3A			4A			5A		
Output voltage (V)	2.5	3.3	5	2.5	3.3	5	2.5	3.3	5
Input voltage (V)	8~20								
Output current (A)	0~3			0~4			0~5		
Voltage regulation accuracy (%)	±5								
Efficiency Typ. (%)	87	89	92	85	88	92	83	87	91
Oscillation frequency Typ. (kHz)	250								
Ripple voltage p-p Typ. (mV)	25								
Overcurrent protection	Operation / auto-recovery at a current lower than the rated current								
Thermal protection Typ. (°C)	150								
Operating (ambient) temperature (°C)	-10~80								

Efficiency and ripple voltage conditions: Vin = 12V and Io = rated output current

R5: Example R5 = 47Ω +/- 0.5% for 2.5V, R5 = 300Ω + 470Ω (series) +/- 0.5% for 3.3V
R5 = 1kΩ + 1.3Ω (series) +/- 0.5% for 5V

◆ 6 – 2 For use with output voltage higher than 5.3V

1) Basic connection of input/output terminals

- Pins 9, 23 and 27 are the test terminals and must be left open.
 - Pins 7, 10, 15, 17, 22, 24, 29 and 31 are internal non-connecting pins (N/C terminals).
 - Figure 6-B shows the external parts and their connections. Be sure to prepare and connect these items before using the device.
 - Output capacitors (C5) minimizes switching frequency ripple and provide a smooth and stable output voltage. The use of a low-impedance capacitor is recommended (low impedance provides minimum ripple).
- Note: Please ask for our advice when setting the output voltage for higher than 5.3V.

● Standard connections (Figure 6-B)

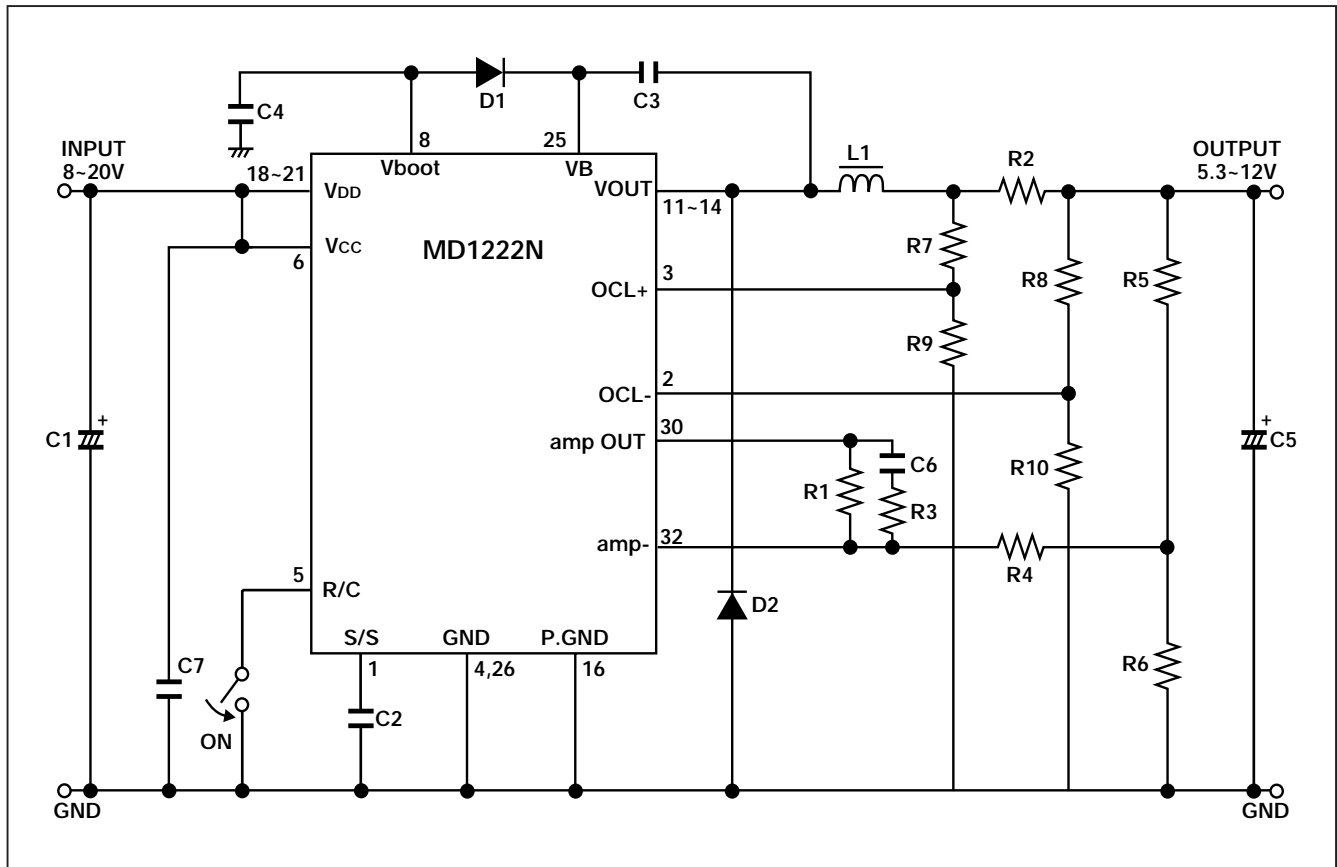

2) Usable input voltage range

For setting the output voltage higher than 5.6V, the minimum input voltage should be determined as follows.

$$V_{in}(\min) \geq \frac{V_{out}}{0.7} \text{ [V]}$$

3) For output voltage higher than 5.3V, the drooping resistances R2, R7, R8, R9 and R10 should be used as follows, provided that the voltage at the 2nd and 3rd pins is less than 5.3V.

$$R9 = R10 = 1\text{k}\Omega$$

$$R7 = R8 = 193 \times (V_{out} - 4.99\text{V}) \text{ [\Omega]}$$

$$R2 = \frac{(V_{out} - 1.53)}{105} \text{ [\Omega]}$$

Note 1: R7, R8, R9 and R10 are added for setting the output voltage to be higher than 5.3V, and the drooping point is significantly moved. Therefore, parts having a precision of less than +/-0.5% should be used for R7, R8, R9 and R10 and less than 5% for R2.

4) Reference parts

Part No.	Nomenclature	Output voltage 5.3V~8V		Output voltage 8V~12V	
		Output current example			
		2 A	3 A	1 A	2.5 A
L1	Choke	47μH 2A	33μH 3A	120μH 2A	47μH 2.5A
D1	Diode	HSU119 (80V 0.3A)	HSU119 (80V 0.3A)	HSU119 (80V 0.3A)	HSU119 (80V 0.3A)
D2	Shottky barrier diode	D1FS4A (40V 1.5A)	D1FS4A (40V 1.5A)	D1FS4A (40V 1.5A)	D1FS4A (40V 1.5A)
C1	Electrolyte capacitor	25V 330μF 1030mA	25V 680μF 1820mA	25V 220μF 760mA	25V 470μF 1250mA
C2	Ceramic capacitor	25V 0.047μF	25V 0.047μF	25V 0.047μF	25V 0.047μF
C3	Ceramic capacitor	25V 0.01μF	25V 0.01μF	25V 0.01μF	25V 0.01μF
C4	Ceramic capacitor	25V 0.01μF	25V 0.01μF	25V 0.01μF	25V 0.01μF
C5	Electrolyte capacitor	16V 680μF 38mΩ	16V 1000μF 23mΩ	16V 330μF 72mΩ	16V 680μF 38mΩ
C6	Ceramic capacitor	25V 1000pF	25V 1000pF	25V 1000pF	25V 1000pF
C7	Ceramic capacitor	50V 0.01μF	50V 0.01μF	50V 0.01μF	50V 0.01μF
R1	Resistance	0.1W 1MΩ	0.1W 1MΩ	0.1W 1MΩ	0.1W 1MΩ
R2	Resistance	It is determined using the expression in Item 6-2 (3).			
R3	Resistance	0.1W 100kΩ	0.1W 100kΩ	0.1W 100kΩ	0.1W 100kΩ
R4	Resistance	0.1W 10kΩ	0.1W 10kΩ	0.1W 10kΩ	0.1W 10kΩ
R5	Resistance	It is determined using the expression in Item 6-1 (2).			
R6	Resistance	0.1W 2.2kΩ ± 0.5%	0.1W 2.2kΩ ± 0.5%	0.1W 2.2kΩ ± 0.5%	0.1W 2.2kΩ ± 0.5%
R7	Resistance	It is determined using the expression in Item 6-2 (3).			
R8	Resistance				
R9	Resistance	0.1W 1kΩ ± 0.5%	0.1W 1kΩ ± 0.5%	0.1W 1kΩ ± 0.5%	0.1W 1kΩ ± 0.5%
R10	Resistance	0.1W 1kΩ ± 0.5%	0.1W 1kΩ ± 0.5%	0.1W 1kΩ ± 0.5%	0.1W 1kΩ ± 0.5%

5) Electrical characteristics (Ta=25°C)

Efficiency and ripple are measured according to external reference parts circuit configuration that is based on standard circuit configuration (Figure 6-B).

Item	Output current example			
	1A		2.5A	
Output voltage (V)	9	12	9	12
Input voltage (V)	13~20	17.5~20	13~20	17.5~20
Output current (A)	0~1		0~2.5	
Voltage regulation accuracy (%)	± 5			
Efficiency Typ. (%)	94	94	95	95
Oscillation frequency Typ. (kHz)	250			
Ripple voltage p-p Typ. (mV)	25			
Overcurrent protection	Operation / auto-recovery at a current lower than the rated current			
Thermal protection Typ. (°C)	150			
Operating (ambient) temperature (°C)	-10~80			

The requirement for efficiency and ripple voltage is: Vin = 15V and Io = the rating current for Vo = 9V;
Vin = 17.5 V and Io = the rating current for Vo = 12V.

Example R5= 2kΩ + 3.9kΩ (series) +/- 0.5% for 9V, R2 = 0.068Ω +/- 5%, R7 = 750Ω + 20Ω (series) +/- 0.5%
R5= 5.6kΩ + 3kΩ (series) +/- 0.5% for 12V, R2 = 0.1Ω +/- 5%, R7 = 1.2kΩ + 150Ω (series) +/- 0.5%

◆ 6 – 3 Remote ON/OFF Control Function

The remote ON/OFF control function can be used for turning output ON and OFF without making or breaking the input. The function can also be employed in systems such as sequence control for a power supply system.

- * When the R/C function is not used, be sure to connect R/C terminal (Pin 5) and ground (Pins 4 and 26).
- * The R/C terminal can be turned ON and OFF by a switch element such as a transistor or MOSFET. However, be sure to add a condenser (1000 pF - 0.1 micro F) across the R/C terminal (Pin 5) and ground (Pins 4 and 26) to prevent misoperation by noise.

Refer to Fig. 6 - C and D shown below.

- * Since pull-up has been carried out in the module, there is no need of impressing the voltage from the outside.

● R/C Functional Terminal Internal Equivalent Circuit (Figure 6-C)

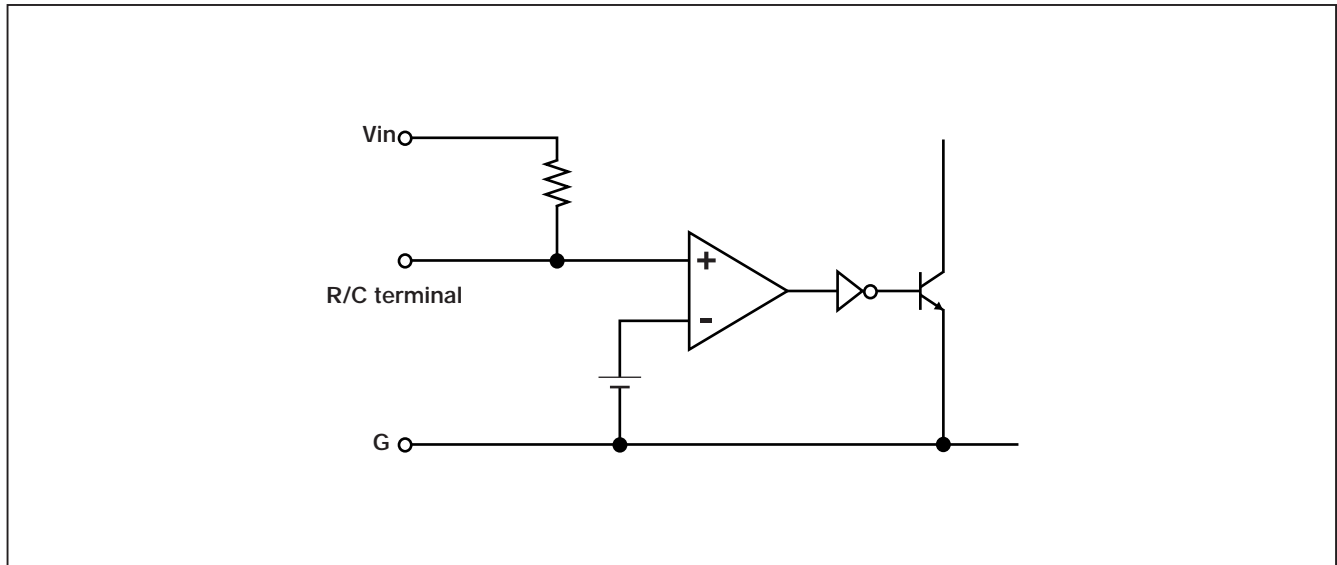

● Method of Connecting R/C Functional Terminals (Figure 6-D)

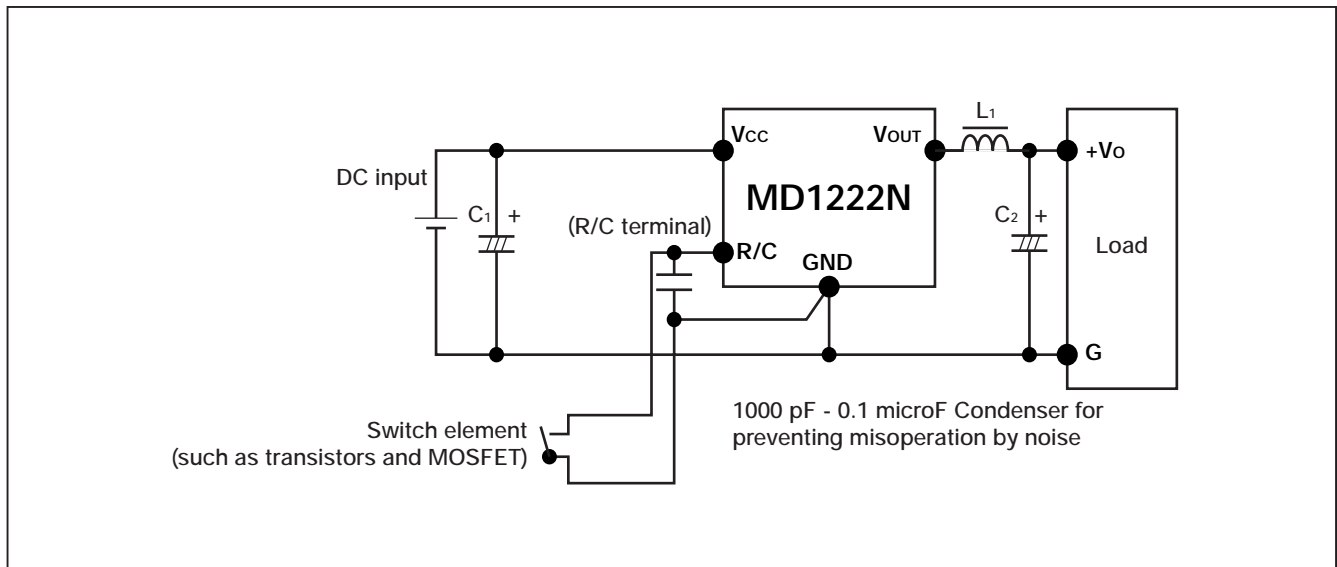

◆ 6 – 4 Input protection element connection

⚠ Caution

The MD1222N device has an output current drop function. In the event of power IC device malfunction resulting in excessive input current flow, smoke and flame may be emitted from the equipment. To prevent this, install a fuse or protective circuitry to the power IC device input line.

Install the fuse or protective circuitry to the positive side of the input line (Figure 6-2, DC input). Be sure that the fuse or protective circuitry is not too large to effectively protect the circuitry (the input line must be capable of carrying enough current to blow the fuse).

◆ 6 – 5 Overvoltage protection

The MD1222N power IC device does not have an overvoltage (voltage surge) protection function. If a malfunction occurs in the device internal circuitry, there may be a voltage surge. Output will reflect this surge and damage to equipment may result. Smoke and flame may be emitted from the equipment. To prevent this, be sure to install voltage surge sensing and protection circuitry.

There are a number of ways to protect against voltage surge. Figure 6-D shows a typical voltage surge protection set-up. The voltage surge sensing and protection circuit should be installed as close as possible to the load (away from the output smoothing capacitor).

● Reference part example (Figure 6-D)

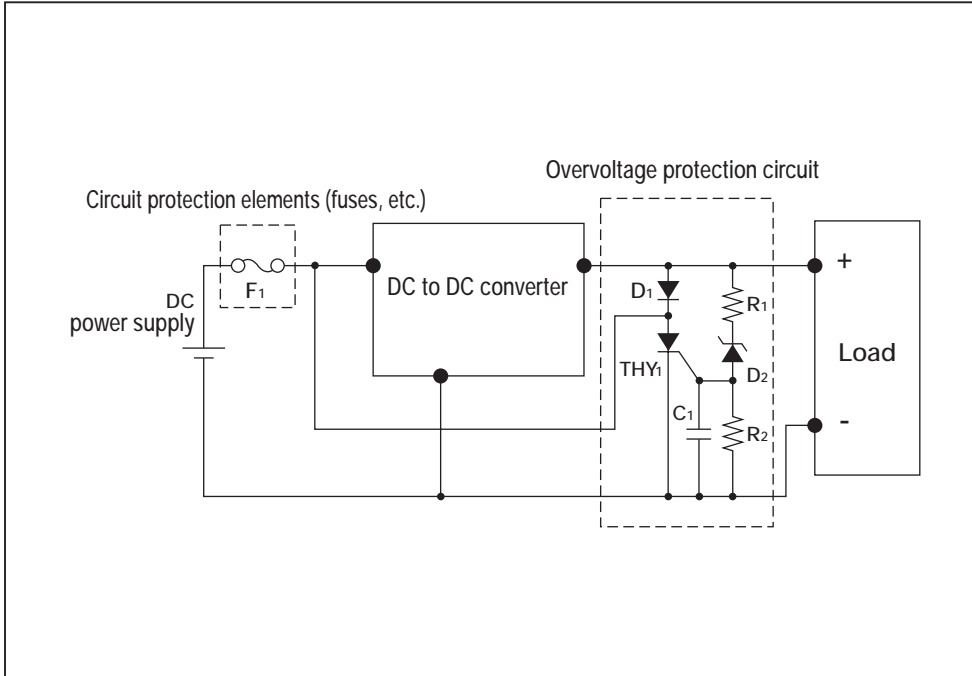

Part No.	Nomenclature	Output voltage example				
		2.5V	3.3V	5V	9V	12V
F1	Circuit protection elements (fuses, etc.)	5A				
R1	Resistance	0.1W 22Ω				
R2	Resistance	0.1W 1kΩ				
C1	Ceramic capacitor	CM316334K10AT 10V 0.33μF				
D1	Diode	M1FL20U 200V 1.1A				
D2	Zener diode	HZM2.5N B1	HZM3.6N B1	HZM5.6N B1	HZM11N B1	HZM15N B1
		3.1~3.35V (5mA)	3.4~3.65V (5mA)	5.31~5.55V (5mA)	10.44~10.88V (5mA)	13.84~14.46V (5mA)
THY1	Thyristor	3P4J – Z 400V 3A				

Conditions: At rated output current

7 Basic device set-up standards

Set-up sequence below

Areas that must be carefully considered in the set-up of the device include the overcurrent detecting resistor, circuit inductance, output capacitor, input capacitor, and thermal characteristics. (Standard connections (Figures 6-A, 6-B))

◆ 7 – 1 Overcurrent detecting resistor (R2) selection (Output voltage lower than 5.3V)

Detects a peak voltage across the resistor of $0.19V \pm 15\%$

$$R2 = \frac{V_R}{I_R} [\Omega]$$

※ Switching noise and other factors may cause some variation in the calculated drop point value. Check your own equipment and calculate the value accordingly.

V_R : 0.19V (voltage produced at R2)

I_R : Droop point

◆ 7 – 2 Inductance (L1) selection

Inductance is determined so that ΔI is 30% of the rating output current at the maximum input voltage.

$$L1 = \frac{(V_i (\text{max}) - V_o) \times V_o}{\Delta I \times V_i (\text{max}) \times f} [\text{H}]$$

$V_i (\text{max})$ = Maximum input voltage

V_o : Output voltage

ΔI : 30% of output current ($I_o \times 0.3$)

f : Oscillation frequency (250 kHz)

I_o : Output current

Calculated inductance values (L1) shown here represent those used in previously manufactured devices and may not be applicable to your device. The use of an actual value somewhat higher than the measured value is standard procedure. However, actual values lower than the measured value may be used where the rated current is low. Use the formula to back-calculate the ΔI using the selected L1 value. The recommended value is $0.2 \times I_o \leq \Delta I \leq 0.4 \times I_o$ (10 - 20% of output current $\times 2$).

● Choke (L1) current

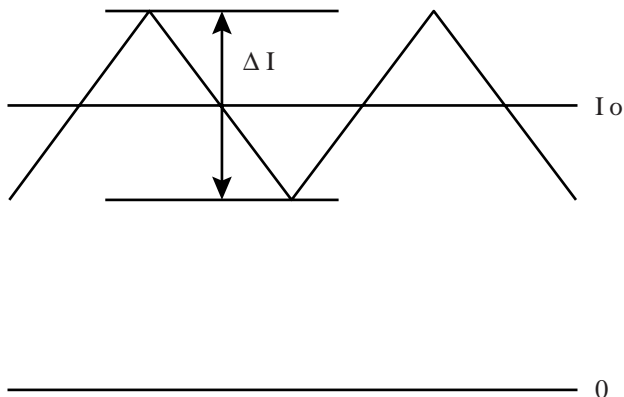

◆ 7 – 3 Output capacitor (C5) selection

If an electrolytic capacitor is used, output ripple is determined by ΔI and capacitor impedance. Use the formula below to calculate the value. Select a device providing an impedance (Z_c) lower than the calculated value.

$$Z_c \leq \frac{V_{rip}}{\Delta I} [\Omega]$$

V_{rip} : Output ripple voltage (Ex : 25mV_{P-P})

ΔI : 30% of output current

Z_c : Electrolyte capacitor impedance

◆ 7 – 4 Input capacitor (C1) selection

A large ripple current flows through the input capacitor. Use the formula below to calculate the value. Select a device providing a higher ripple current capacity (I_{rip}) than the calculated value.

$$D = \frac{V_o}{V_i (\text{min})}$$

$$I_{rip} \geq \sqrt{D(1-D)} \times I_o [A]$$

D : Duty

V_o : Output voltage

$V_i (\text{min})$: Minimum input voltage

I_o : Output current

◆ 7 – 5 Thermal management

Temperature increase varies with input voltage, output voltage, and output current. Case surface temperatures should not exceed 105°C. Set-up your equipment accordingly.

8 Electrical data measurement

The data given below is based on standard connection diagrams (Figures 6-A, 6-B), and makeup of reference parts and surface mounted parts modules of reference circuitry patterns.

◆ 8 – 1 Output voltage - 2.5V

● Line regulation

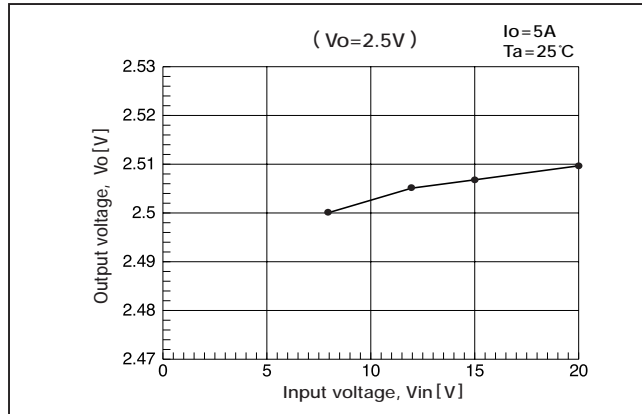

● Load regulation

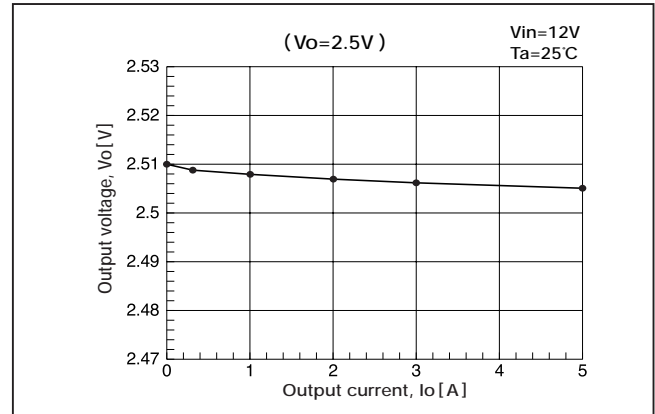

● Temperature drift

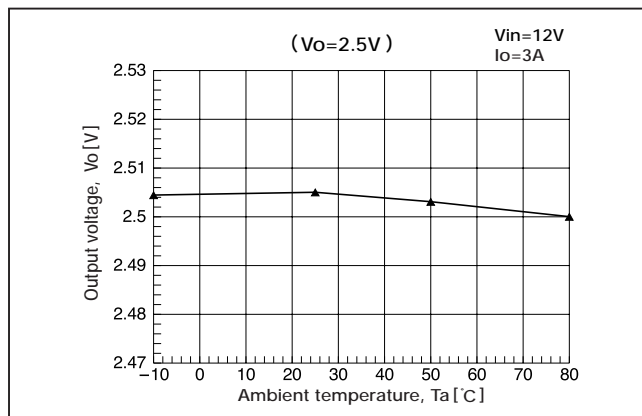

● Efficiency and loss characteristics

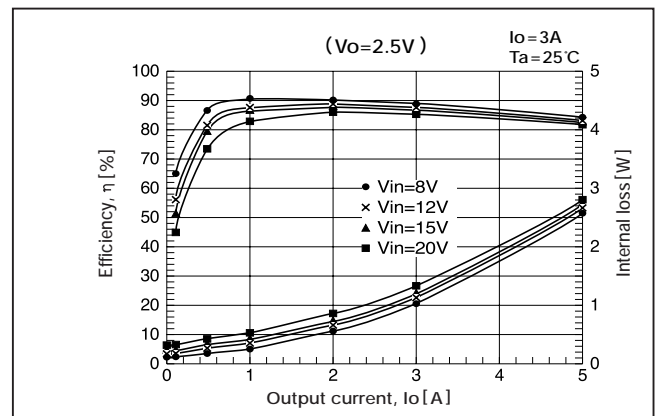

● IC temperature increase

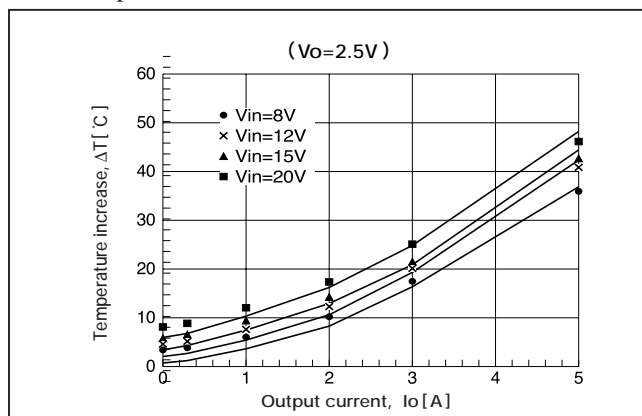

● Derating curve

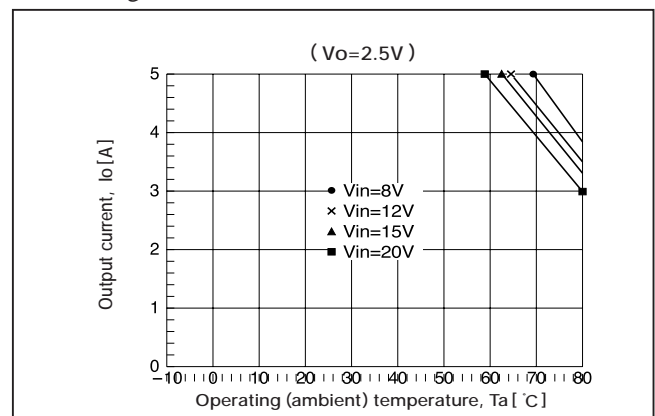

● Input voltage / input current characteristics

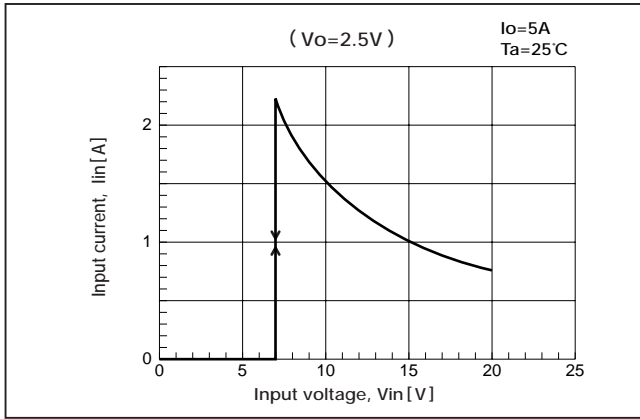

● Input voltage/output voltage characteristics

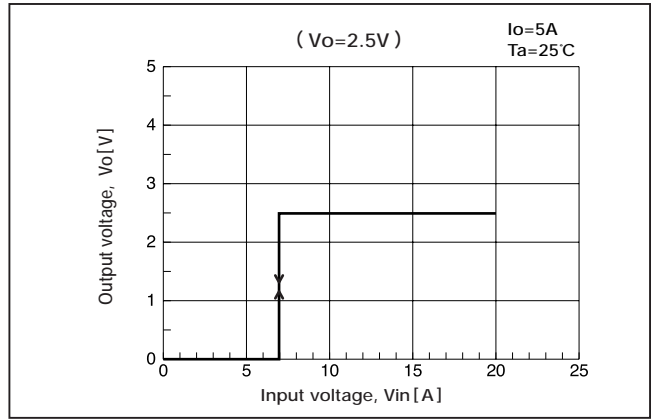

● Current limit characteristic (Input fluctuation)

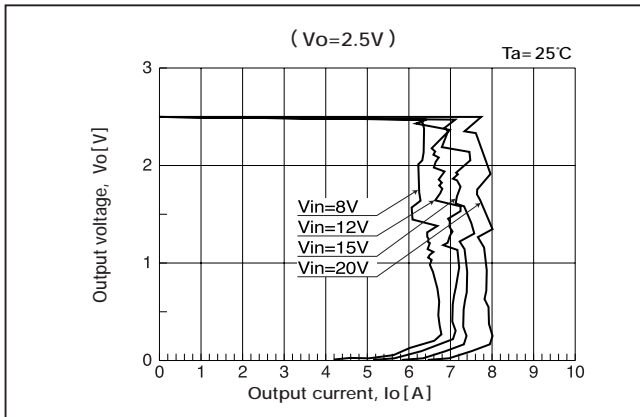

● Current limit characteristic (Temperature fluctuation)

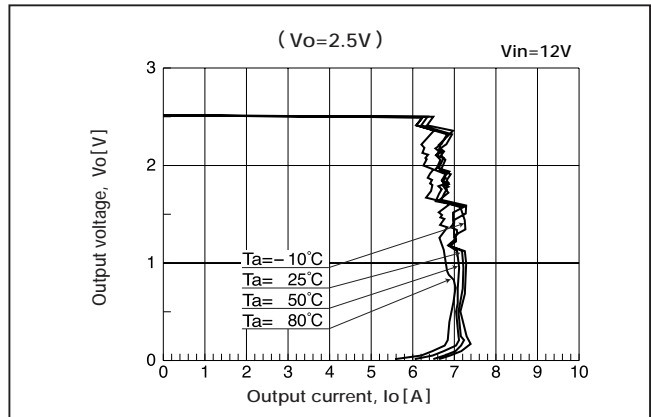

● Start-up rising characteristics

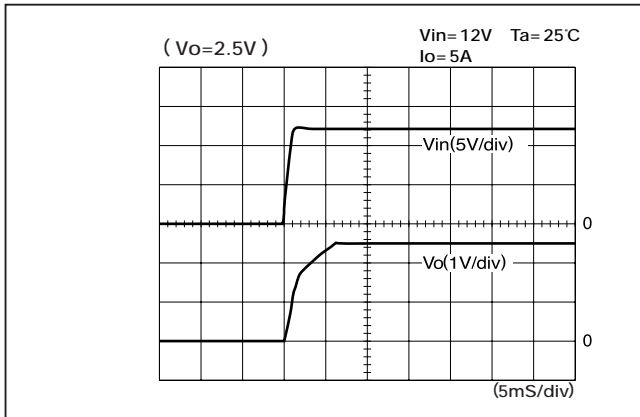

● Shut-down falling characteristics

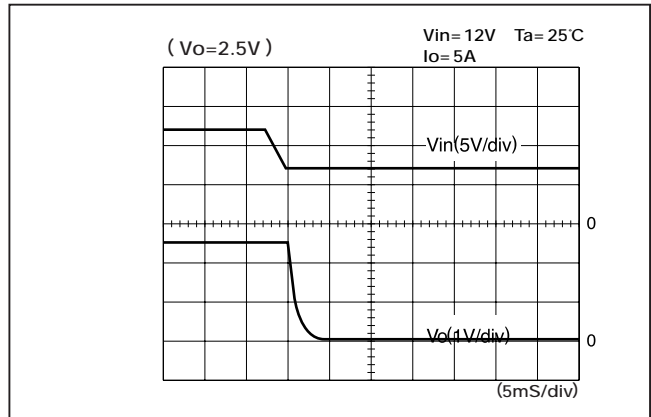

● Rise characteristics with remote control turned ON

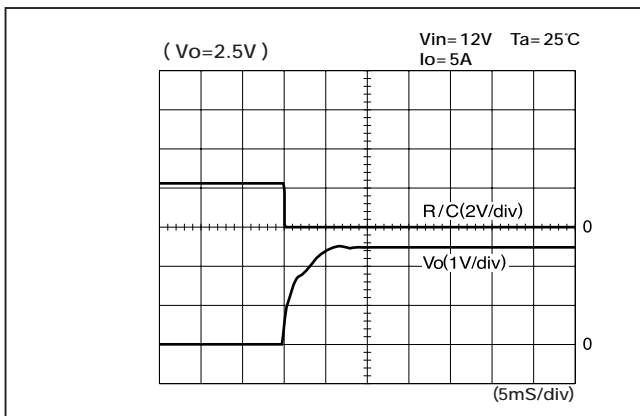

● Down characteristics with remote control turned OFF

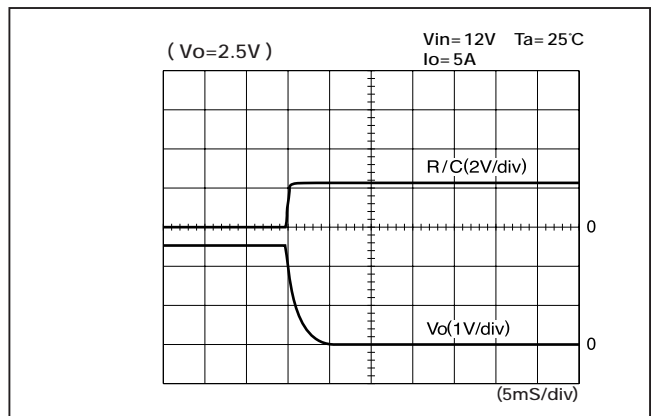

◆ 8 – 2 Output voltage - 3.3V

● Line regulation

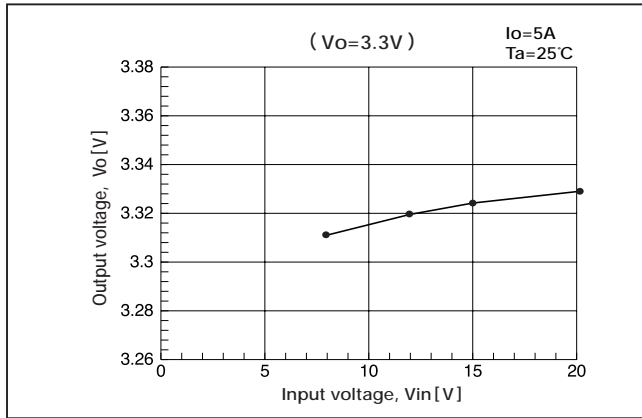

● Load regulation

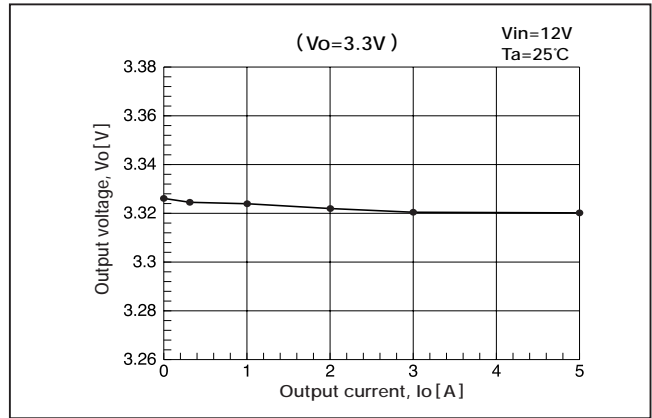

● Temperature drift

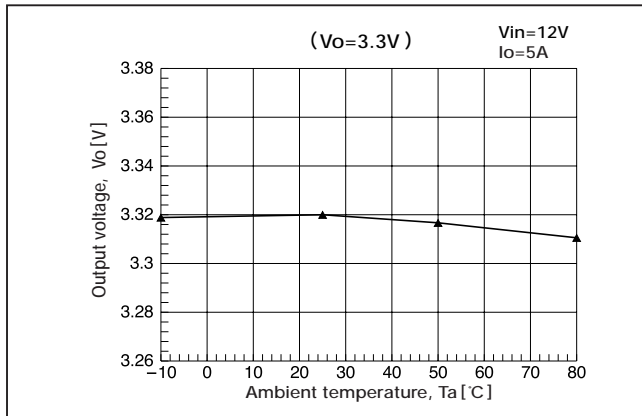

● Efficiency and loss characteristics

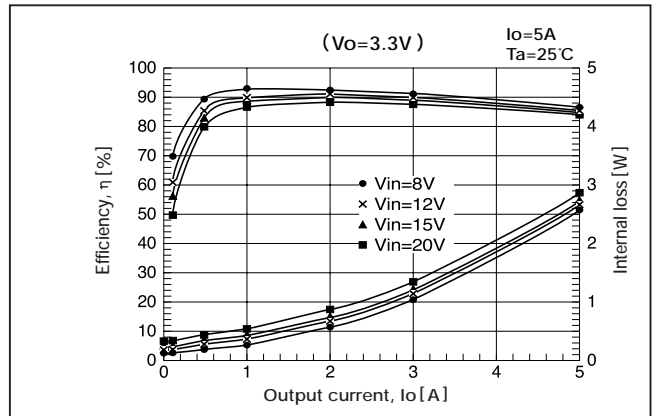

● IC temperature increase

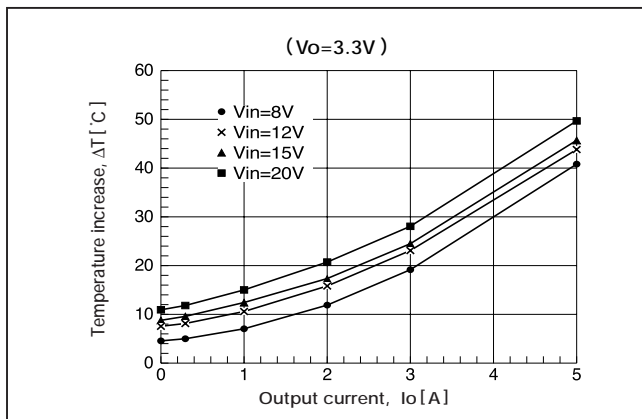

● Derating curve

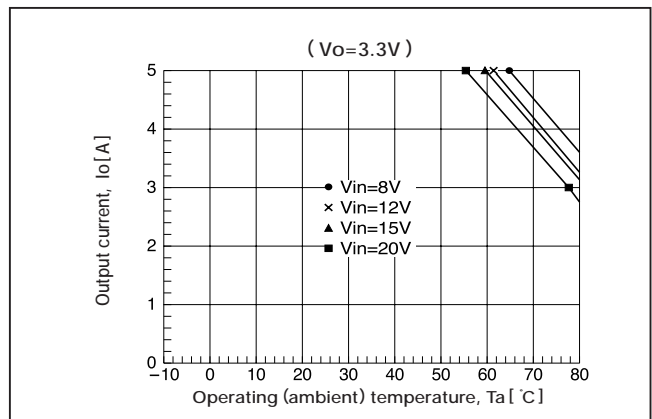

● Input voltage / input current characteristics

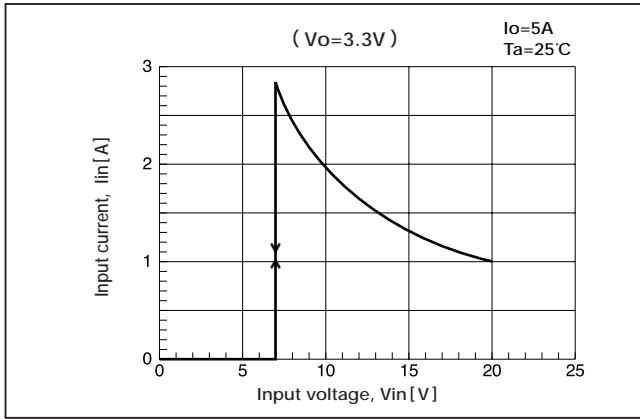

● Input voltage/output voltage characteristics

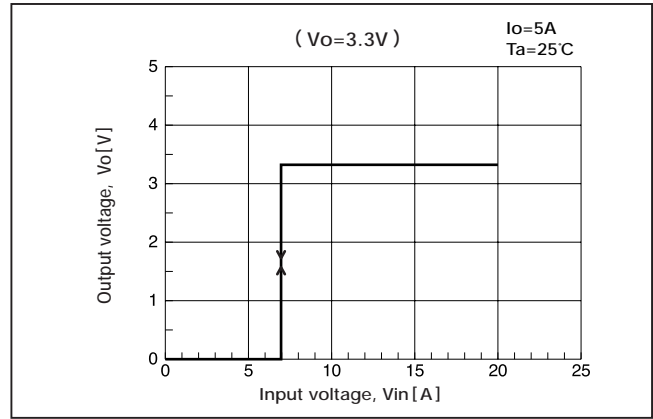

● Current limit characteristic (Input fluctuation)

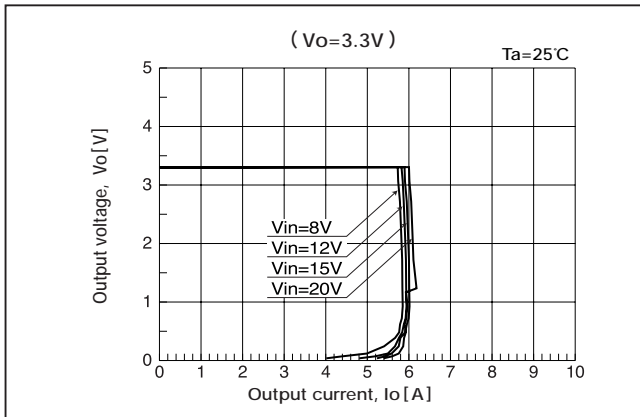

● Current limit characteristic (Temperature fluctuation)

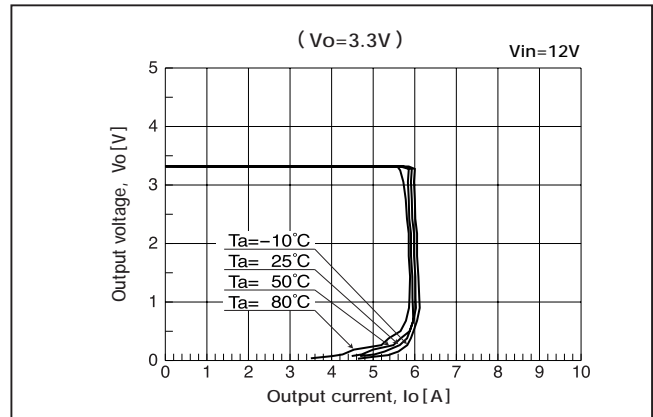

● Start-up rising characteristics

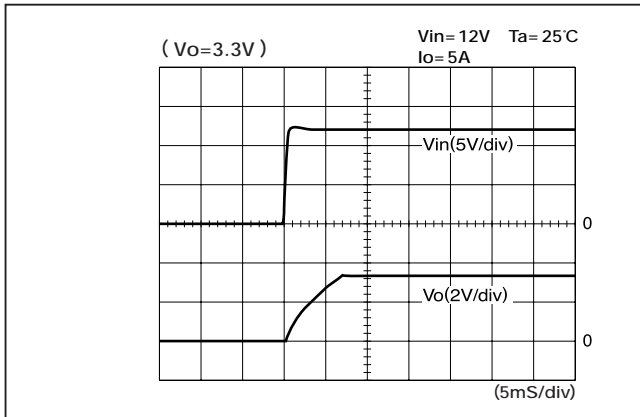

● Shut-down falling characteristics

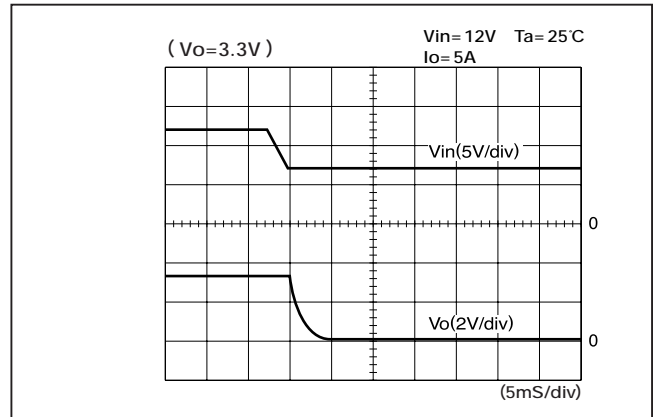

● Rise characteristics with remote control turned ON

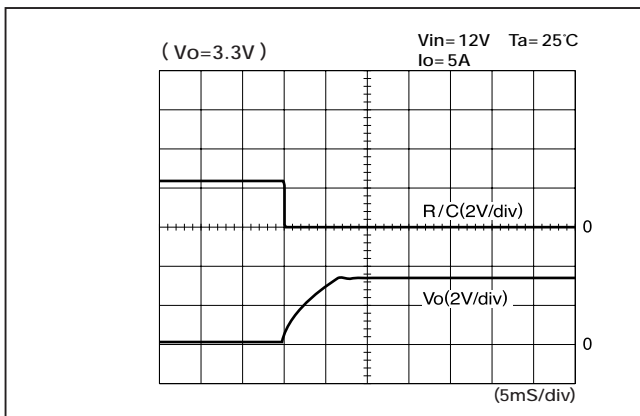

● Down characteristics with remote control turned OFF

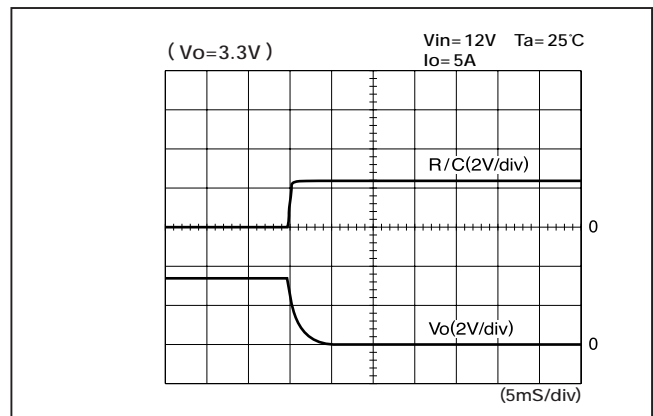

◆ 8 – 3 Output voltage - 5V

● Line regulation

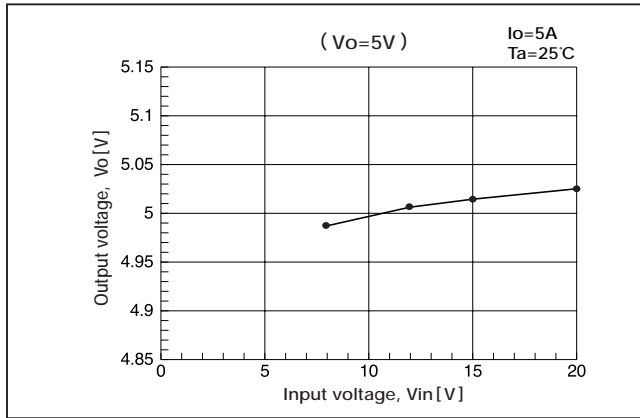

● Load regulation

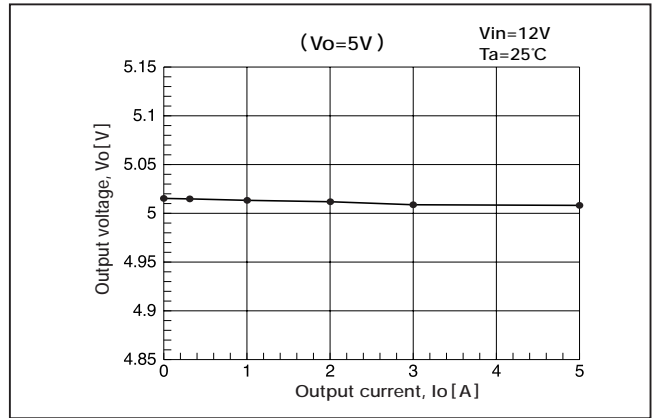

● Temperature drift

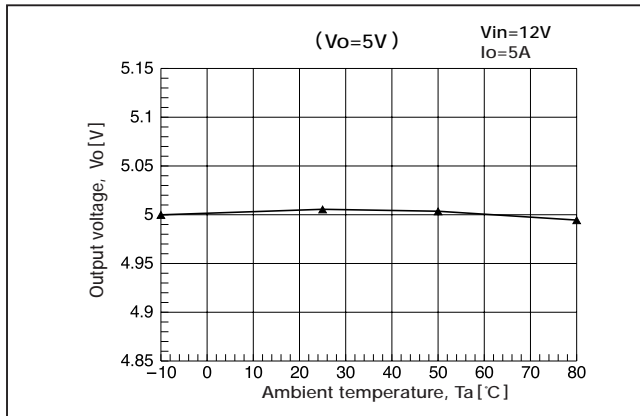

● Efficiency and loss characteristics

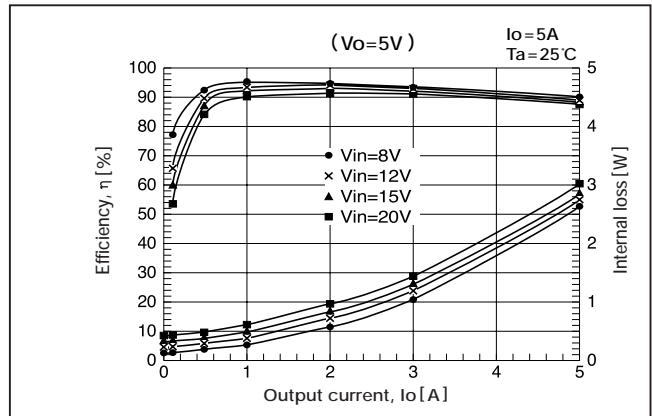

● IC temperature increase

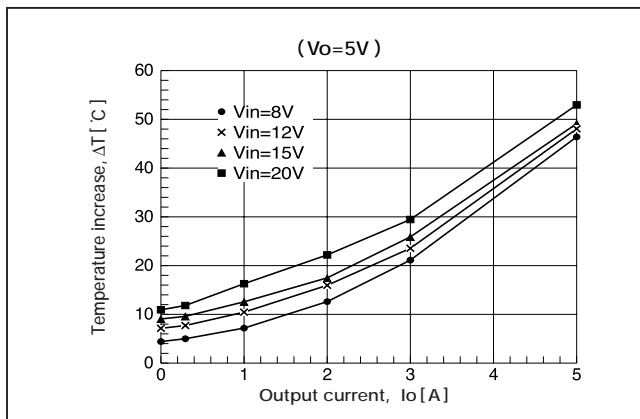

● Derating curve

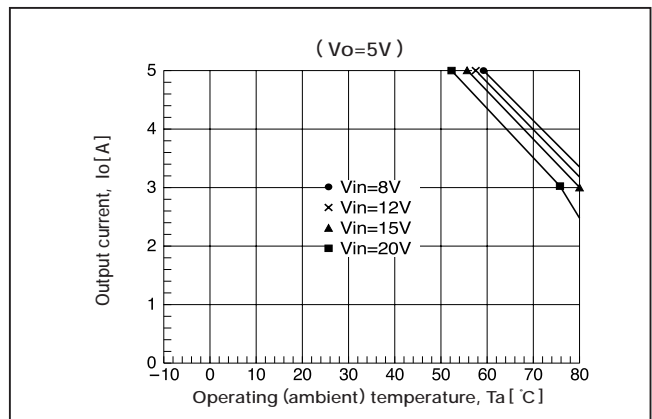

● Input voltage / input current characteristics

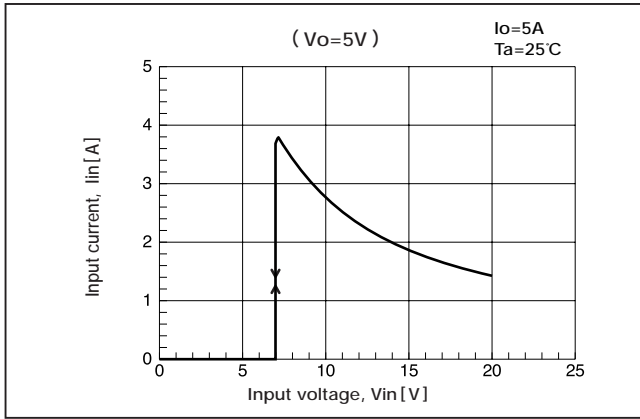

● Input voltage/output voltage characteristics

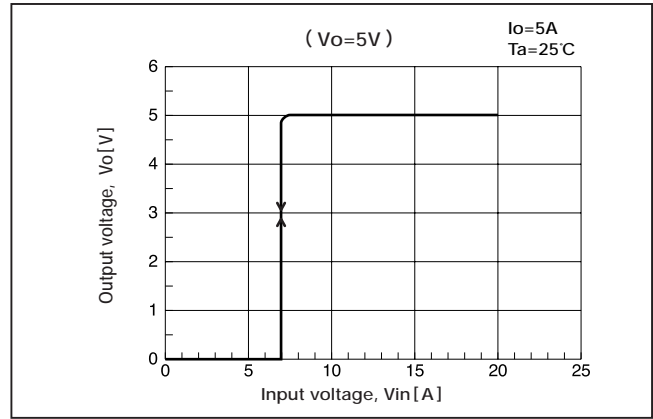

● Current limit characteristic (Input fluctuation)

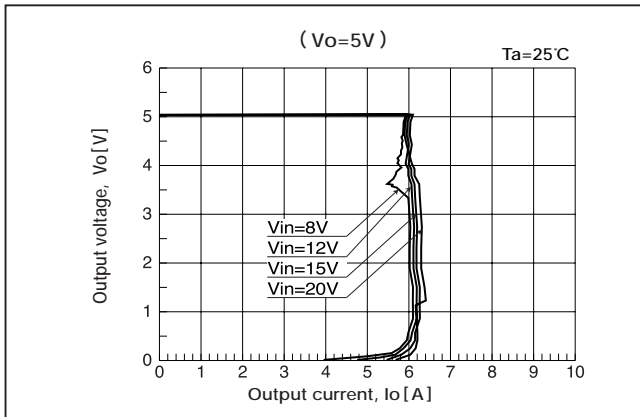

● Current limit characteristic (Temperature fluctuation)

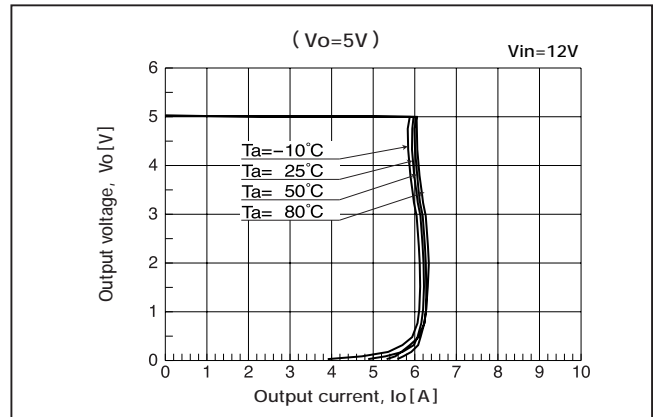

● Start-up rising characteristics

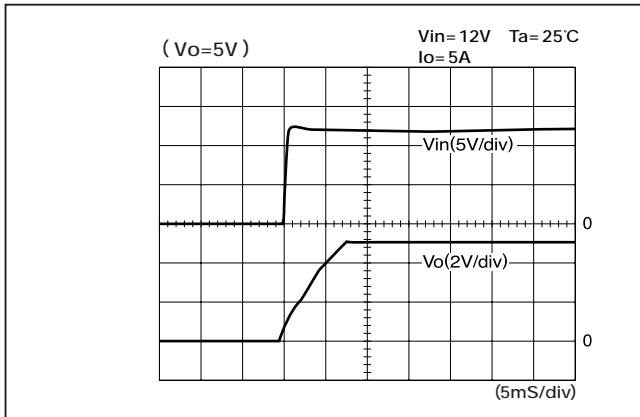

● Shut-down falling characteristics

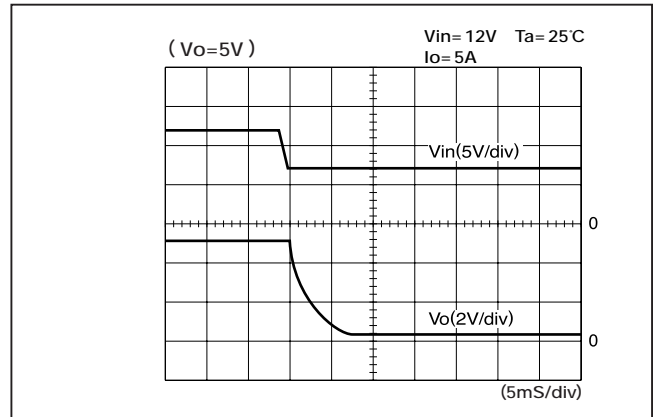

● Rise characteristics with remote control turned ON

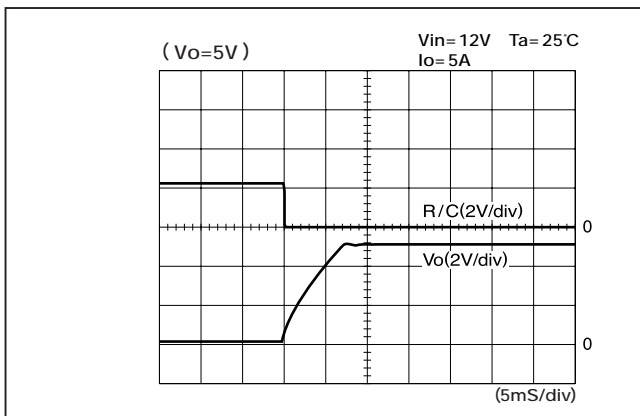

● Down characteristics with remote control turned OFF

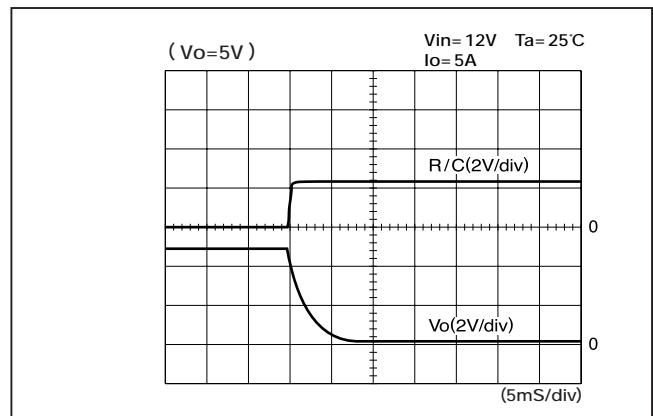

◆ 8 - 4 Output voltage - 9V

● Line regulation

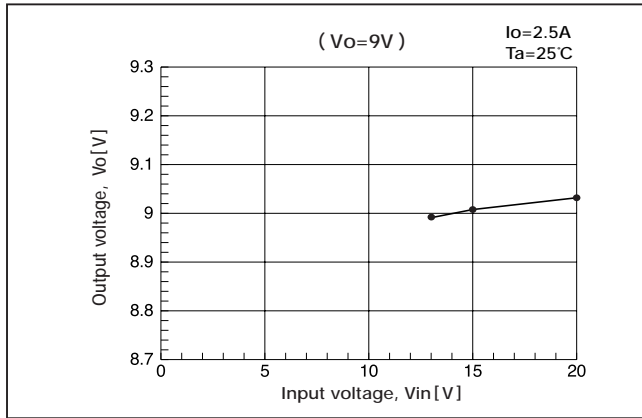

● Load regulation

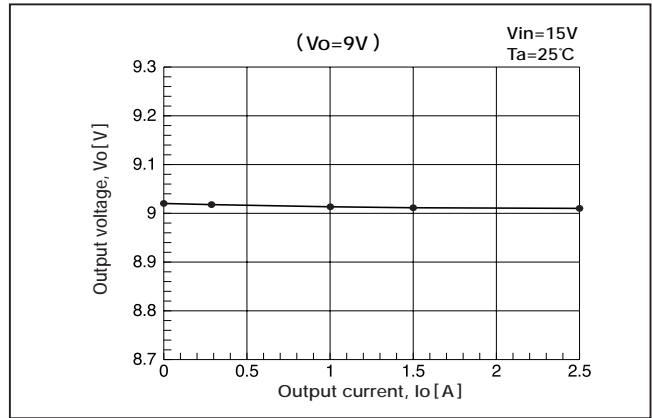

● Temperature drift

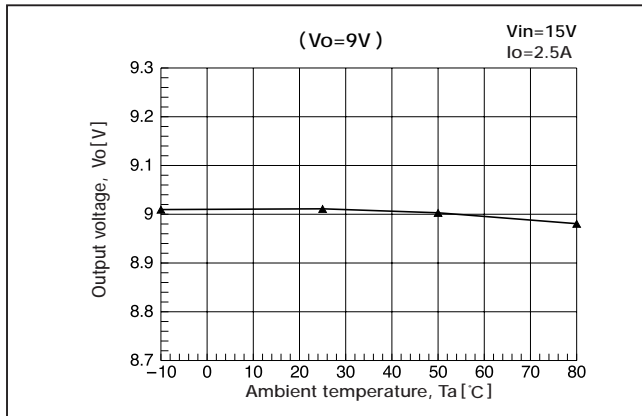

● Efficiency and loss characteristics

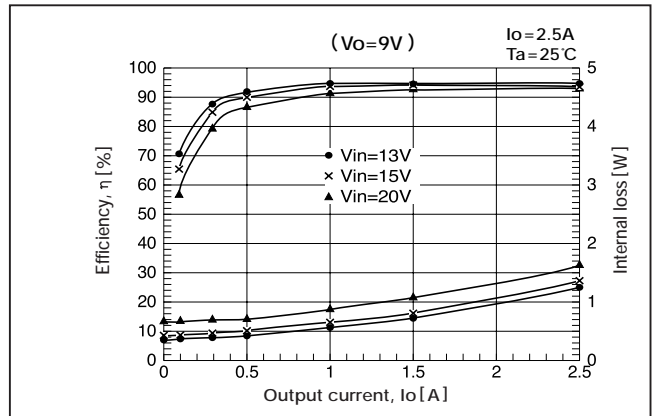

● IC temperature increase

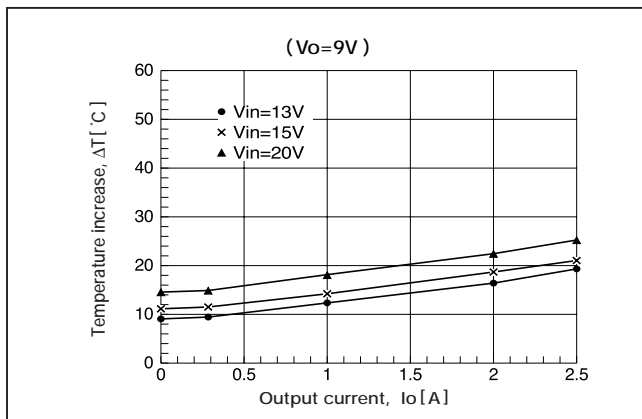

● Derating curve

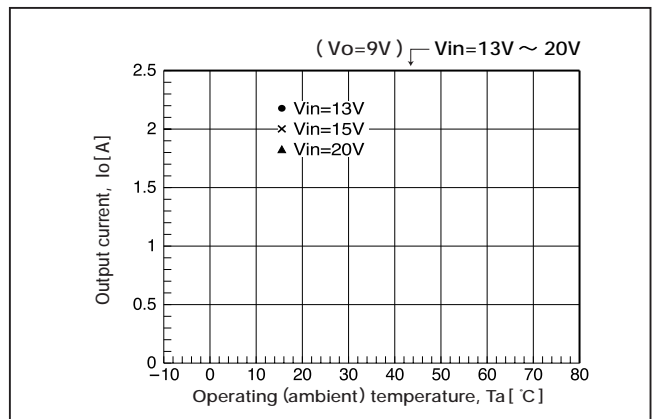

● Input voltage / input current characteristics

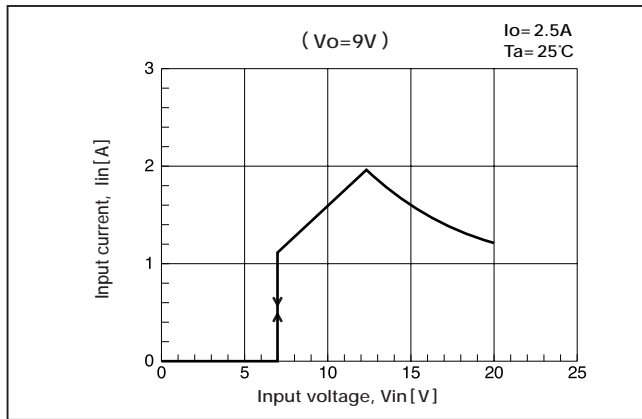

● Input voltage/output voltage characteristics

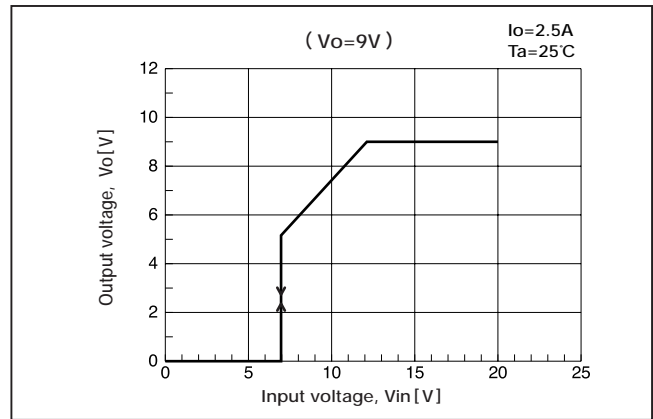

● Current limit characteristic (Input fluctuation)

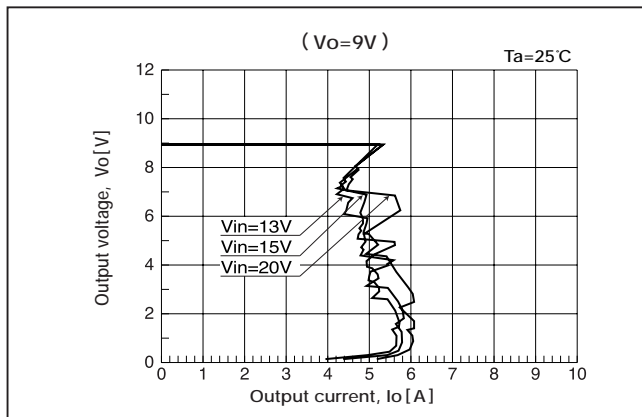

● Current limit characteristic (Temperature fluctuation)

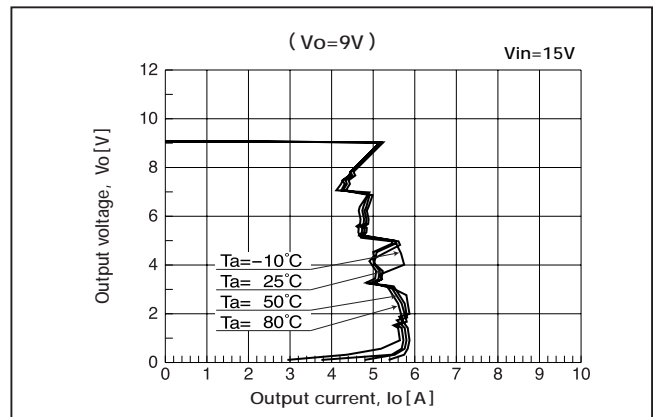

● Start-up rising characteristics

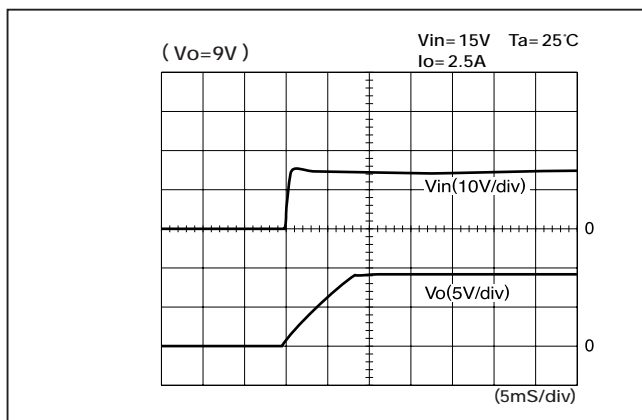

● Shut-down falling characteristics

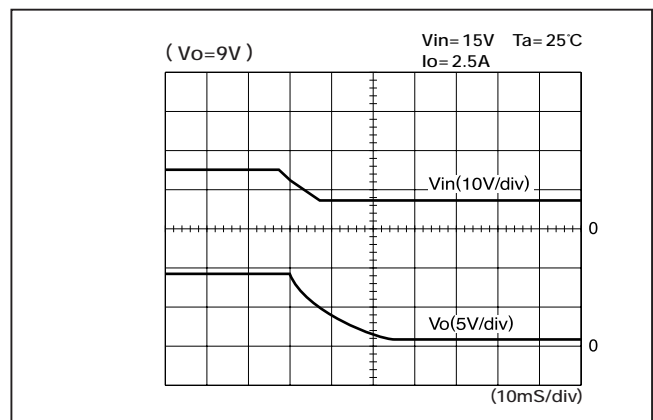

● Rise characteristics with remote control turned ON

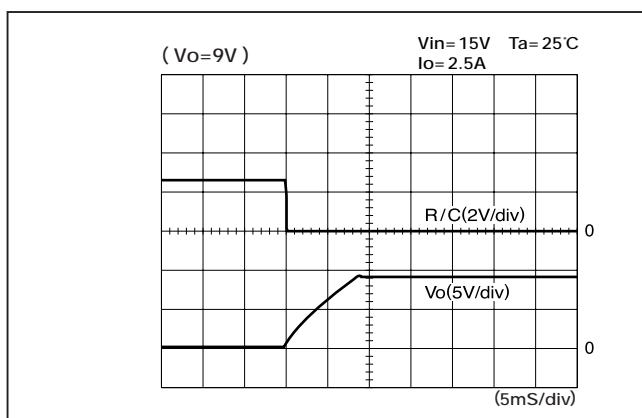

● Down characteristics with remote control turned OFF

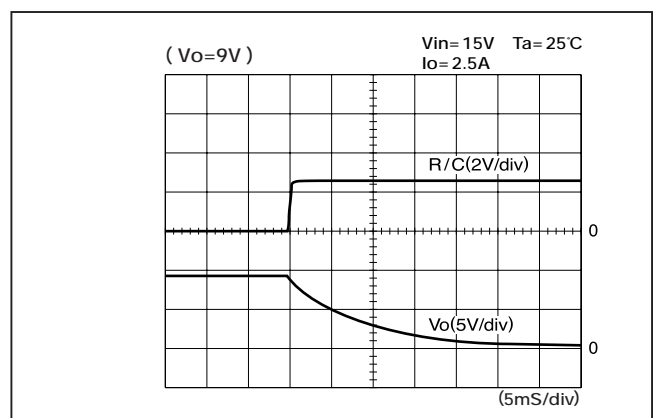

◆ 8 – 5 Output voltage - 12V

● Line regulation

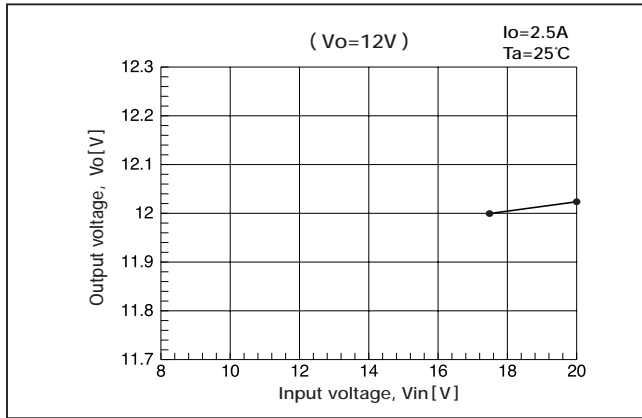

● Load regulation

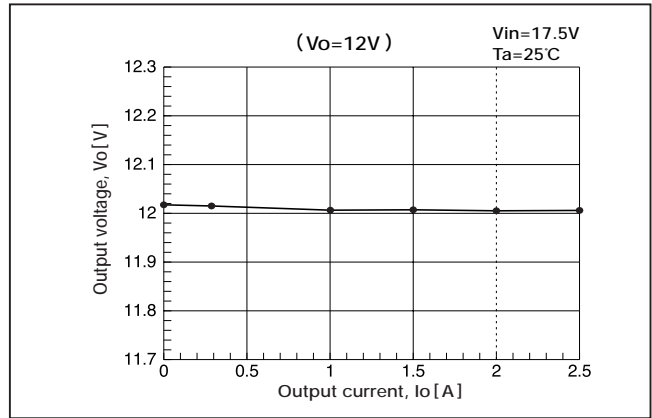

● Temperature drift

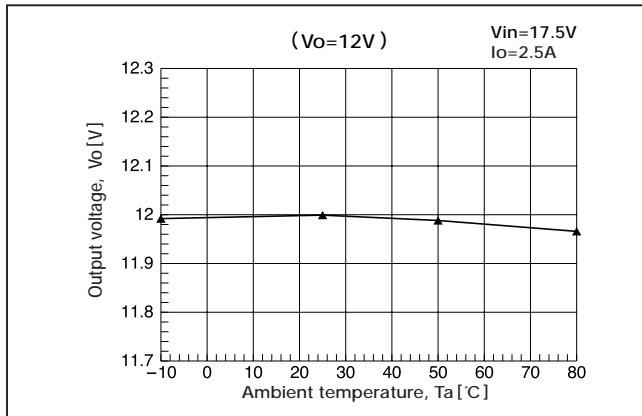

● Efficiency and loss characteristics

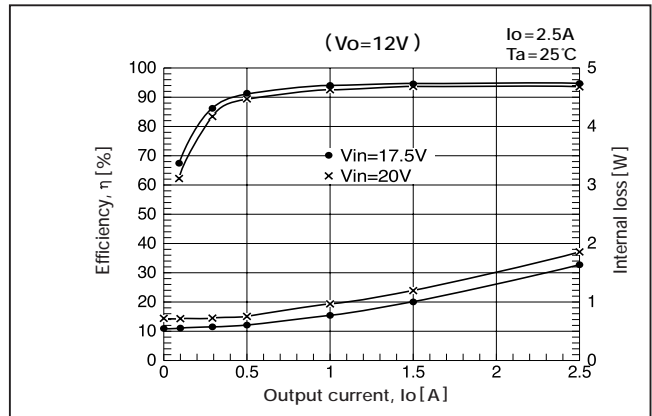

● IC temperature increase

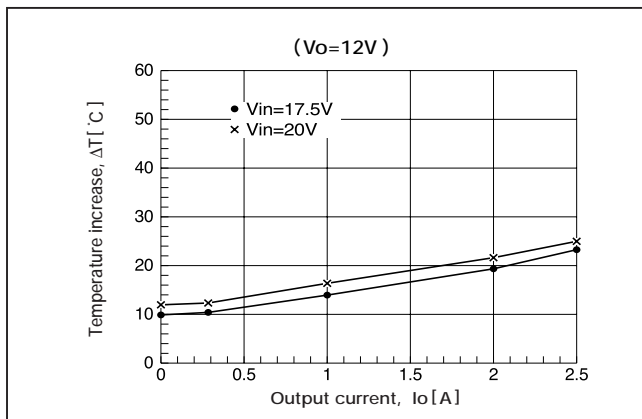

● Derating curve

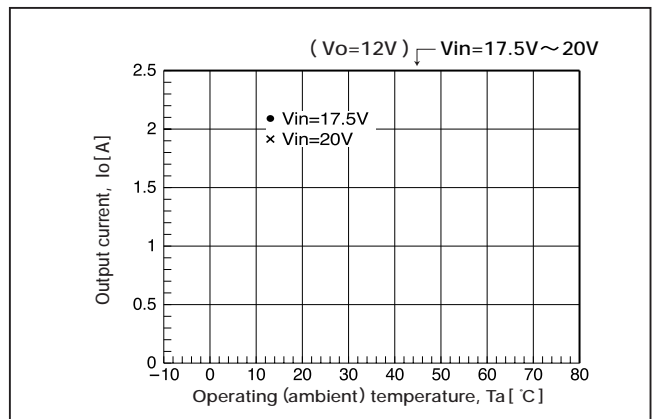

● Input voltage / input current characteristics

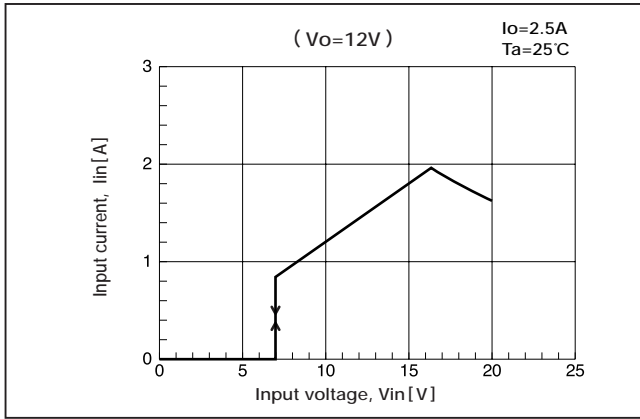

● Input voltage/output voltage characteristics

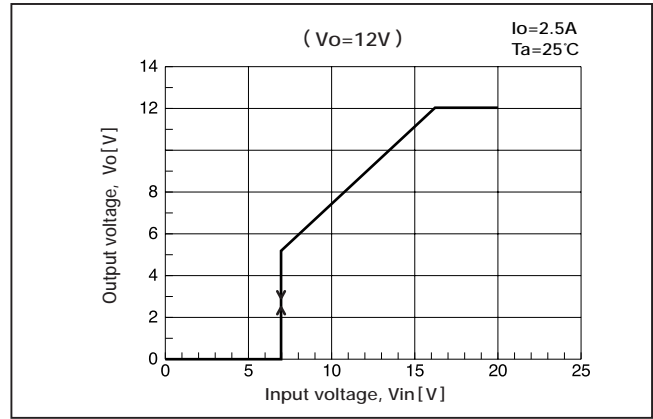

● Current limit characteristic (Input fluctuation)

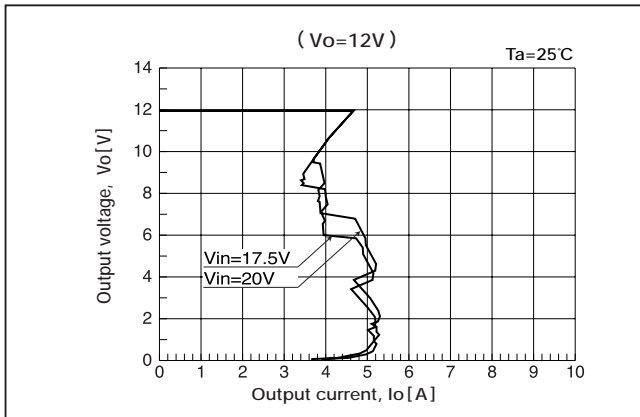

● Current limit characteristic (Temperature fluctuation)

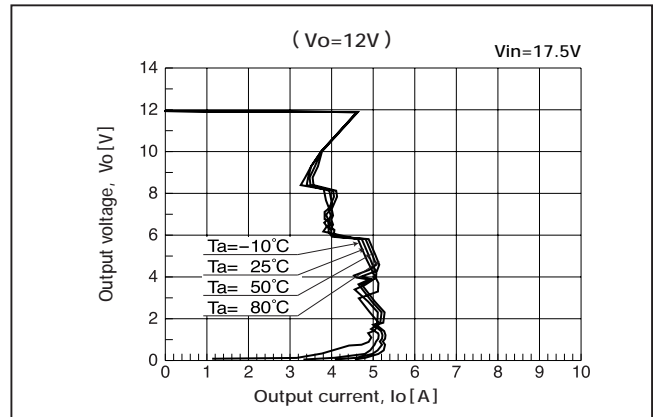

● Start-up rising characteristics

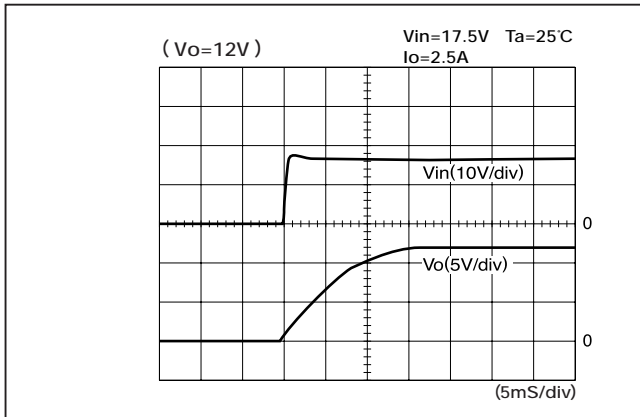

● Shut-down falling characteristics

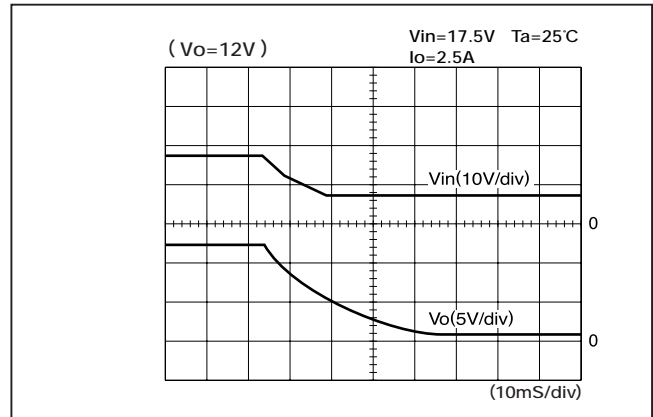

● Rise characteristics with remote control turned ON

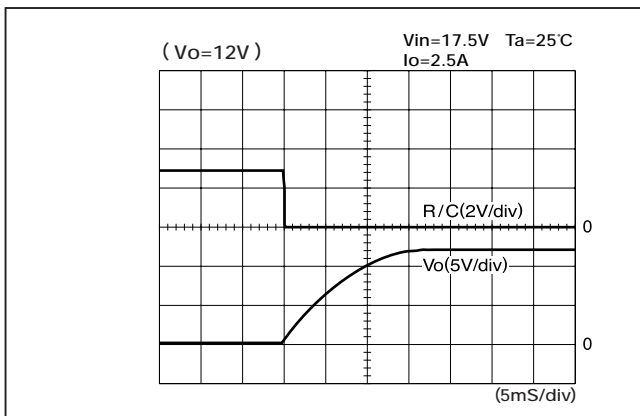

● Down characteristics with remote control turned OFF

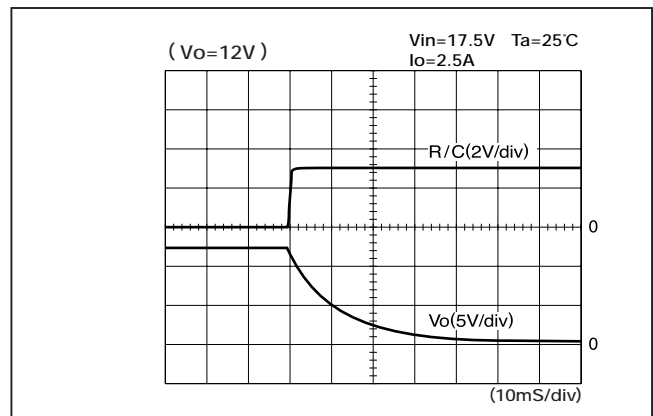

9 Packing

◆ 9 – 1 Tape & Reel

1) Tape

Material : PVC

Dimensions Comply with JIS, C-0806

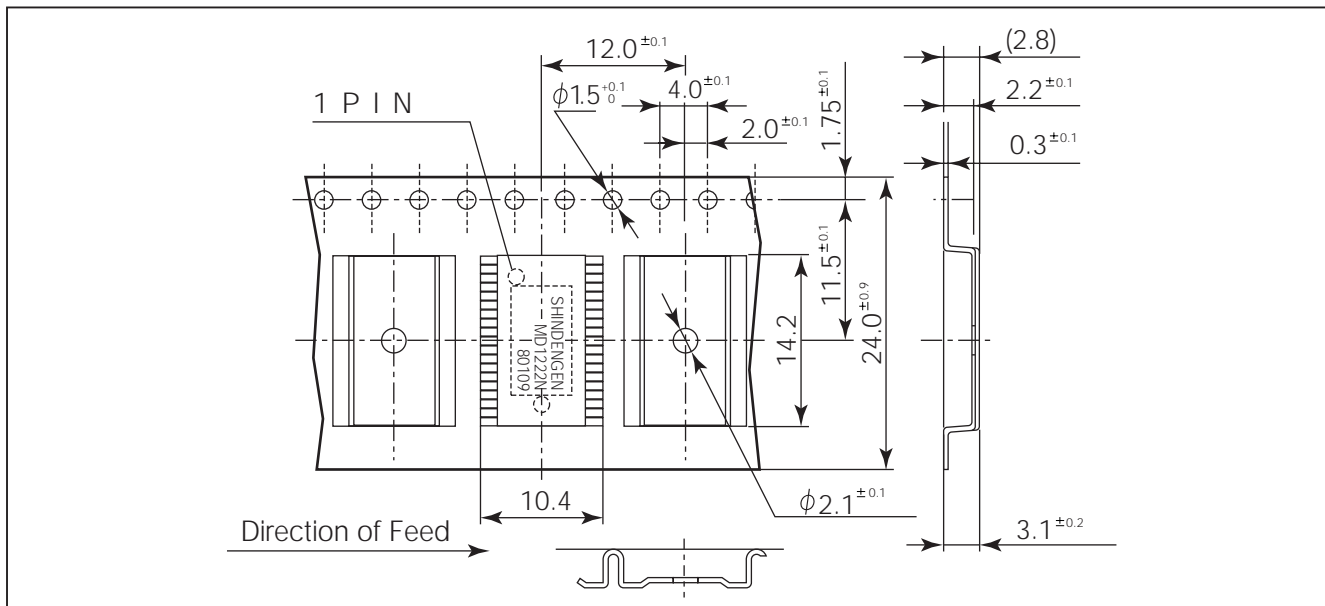

2) Reel

Material : Polystyrene

Dimensions Comply with EIAJ, ETX-7001

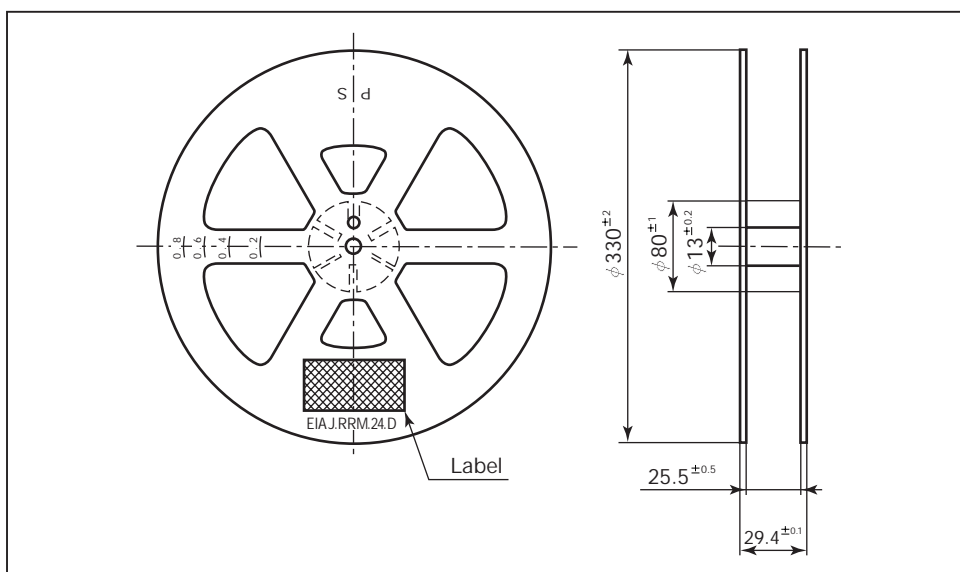

• Label

Type No.
Code No.
Date Code
Quantity
Manufacturer

3) Leader and Trailer

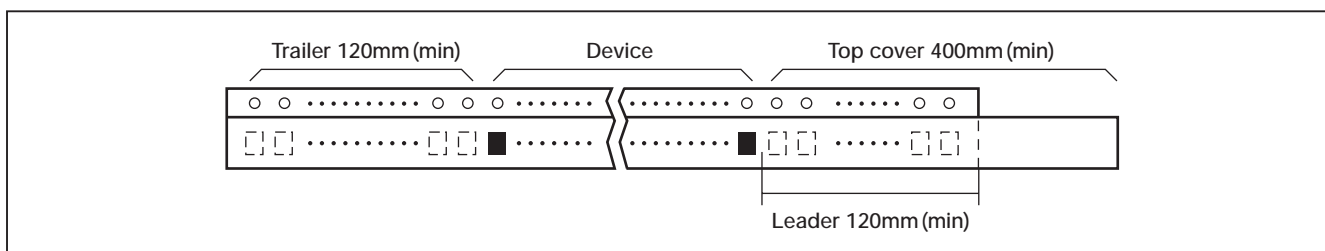

◆ 9 – 2 Packing

- Tape & Reel : 6,000pcs (3 Reels)/Outer Carton

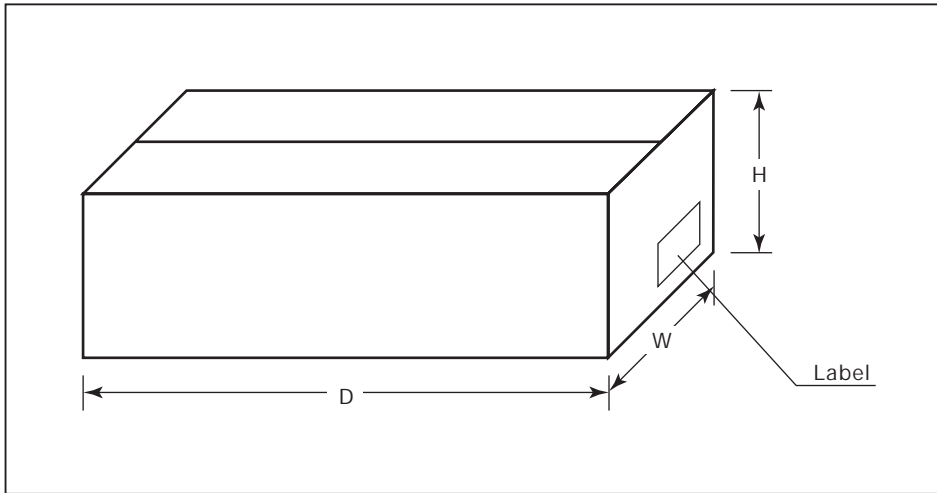

- Marking

Type No. • Code No. • Date Code • Quantities

◆ 9 – 3 Ordering and Dimensions

Package	Code No.	Minimum Ordering Quantities	Quantities Per Inner Carton (pcs.)	Quantities per Outer Carton		Outer Carton(mm)		
				pcs./Carton	Weight (kg)	D	W	H
SSOP-32	4072	2000	2000	6000	7.6	363	363	160

** All specifications are subject to change without notice.*

Please note that the information contained in this catalog may change for improvement or other purpose without notice.

Issued: April 2001

Export regulations of strategic materials, etc.

This product is classified as the integrated circuit specified in Item 7 in the Attached Table No. 1 to the Export Trade Control Order and in Article 6 of the Ordinance of the Ministry of International Trade and Industry.

This product is subject to the KNOW regulation.

April 2001

Shindengen America, Inc.

Head Office

2985 E. Hillcrest Drive, Suite 140
Westlake Village, CA91362, U.S.A.
Phone : (1)-805-373-1130 Fax : (1)-805-373-3710

Chicago Office

411 Business Center Drive, Suite 112
Mt. Prospect, IL 60056 U.S.A.
Phone : (1)-847-827-7100 Fax : (1)-847-827-7122

Shindengen UK Ltd.

Howard Court, 12 Tewin Road,
Welwyn Garden City, Hertfordshire. AL7 1BW
Phone : (44)-1707-332-992 Fax : (44)-1707-332-955

German Representative Office

Kaiser-Strasse 25, D-40479 Dusseldorf, Germany
Phone : (49)-211-491968-0 Fax : (49)-211-4986499



SHINDENGEN
ELECTRIC MFG. CO., LTD.

Ikebukuro office:
RECRUIT Ikebukuro Bldg., 1-13-23, Minami-Ikebukuro,
Toshima-ku, Tokyo 171-0022, Japan
Phone : (81)-03-5951-8106
Fax : (81)-03-5951-8099