

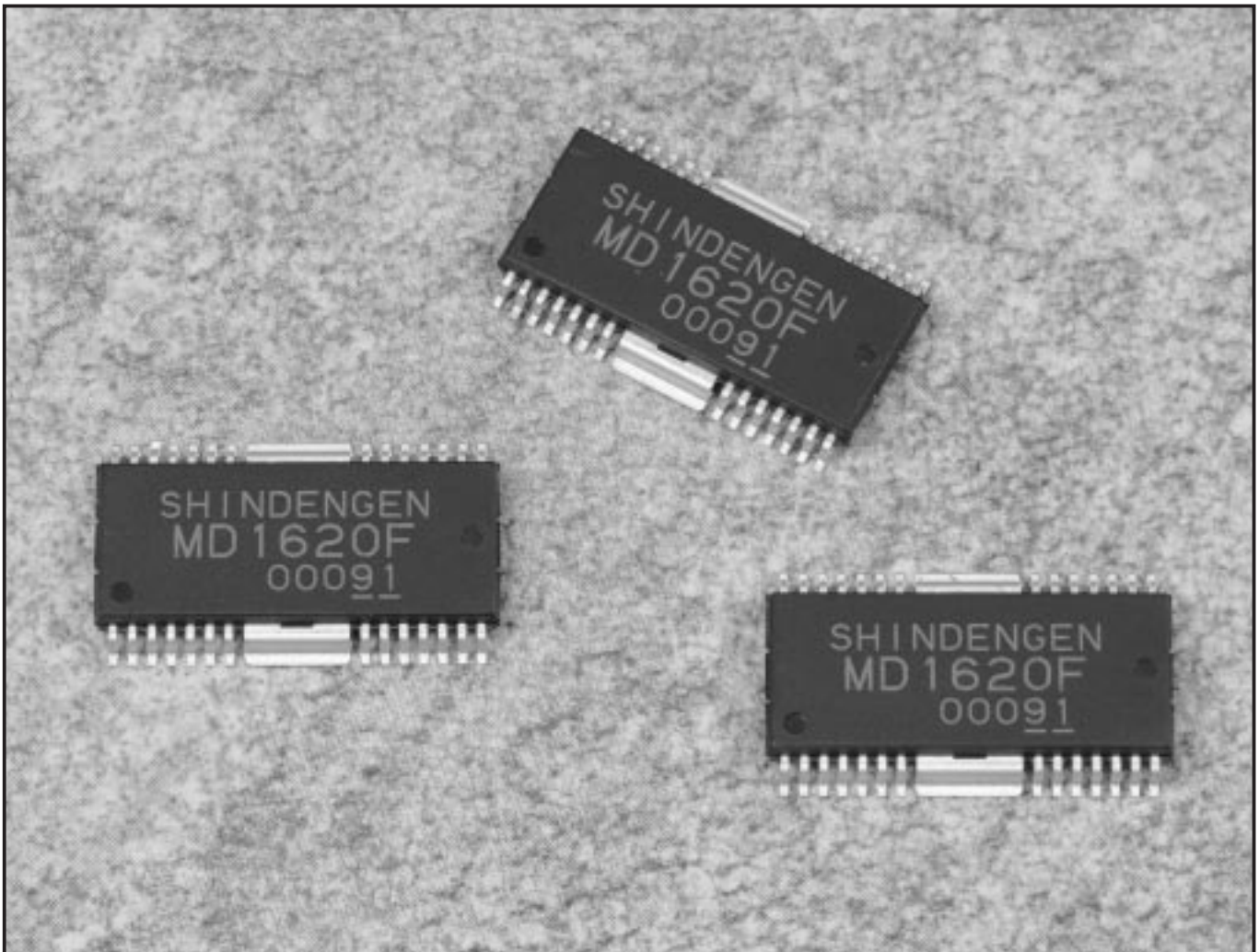

5V Stepdown
DC to DC Converter Power IC
MD1620F
Application Manual



SHINDENGEN ELECTRIC MFG. CO., LTD.

1 Using the MD1620F DC to DC Converter Power IC

Thank you for purchasing the MD1620F DC to DC Converter Power IC. This manual contains important information on the safe use of the MD1620F. Your safety is most important to our company. Please read these instructions carefully before using this device.

CAUTION



The improper use of this device can result in serious injury or death. Expensive damage to this and other equipment can result. Failure to observe the cautions in this Manual can also result in minor injuries and annoying equipment damage.

CAUTION



The MD1620F is intended for use with general electronic equipment (office automation, communication, measurement, household, etc.) It is not intended for use with equipment whose failure might result in the death or injury of those depending upon it (medical treatment, air navigation, railroad, cargo handling, nuclear power, etc.) If you intend to use the MD1620F with other than the general equipment listed above, please consult with our company.



Under no conditions attempt to repair or modify this device by yourself. Doing so can result in electric shock, equipment breakage, fire, and unreliable (and dangerous) equipment operation.



Abnormal operating conditions may result in excessive voltage at the output terminal or excessive voltage drops elsewhere in the device. Take steps to prevent load mishandling and breakage (overvoltage and overcurrent prevention) at the final point in the equipment chain.



Overvoltage protection

The MD1620F is not equipped with an overvoltage protection function. In the event excessive voltage appears within a module, the high input voltage may remain together with a high output voltage even when the equipment is turned off. Smoke and flame may appear. To prevent this, be sure to install some sort of overvoltage protection circuitry before using the equipment.



Before providing electrical power to the device, check that the polarity of the input and output terminals is correct (check for misconnections). If circuit protection circuitry is cut off from the rest of the equipment, smoke and flames may appear.



Be sure that input voltage level is maintained at the specified level. This may require the installation of a voltage regulator to the input line. Voltage fluctuations may result in the appearance of smoke and flames.



If a breakdown or other abnormal condition occurs during equipment use, immediately stop power to the equipment. Contact our company at your earliest possible convenience.

- The information appearing in this Manual is the latest available at the time of publication. We reserve the right to make changes to the device without prior notice. Therefore, your device may differ slightly from that described in this Manual.
- Every effort has been made to make the information in this Manual accurate and reliable. However, our company takes no responsibility for injuries or damage incurred when using the device as described in this Manual. Neither do we take responsibility for damages incurred as a result of patent or other defined rights.
- We do not give consent for a third person to use our patent or other rights based on this material. We do not guarantee these rights.
- No part of this material may be reproduced or copied without the specific written consent of our company.

- This device fully meets the reliability and quality control standards described in our company's catalog. If this device is to be used in a situation where its misuse or failure might cause serious injury or death, consult with our company.
- Reliability and quality control standards for this device are considered adequate when it is used with the following types of end equipment.
Computer - Office automation - Communication terminal - Measurement · Machine tools - Audio-visual - Games and other amusements - Household appliance - Personal items - Industrial robot.
Special applications where the device may or may not be suitable include the following.
Transportation and conveyance (cargo loading) equipment- Primary communications equipment- Traffic signal control equipment - Fire and burglary alarms - Various safety devices - Medical equipment
Other special applications where the device reliability is not considered high enough include the following.
Atomic energy control systems - Aviation equipment- Aeronautics and space equipment - Ocean depth sounding equipment - Life support equipment
- Our company makes a constant effort to improve the quality and reliability of our products. However, it is the customer's responsibility to provide safety. Take the appropriate steps to prevent personal injury, fire, and damage by providing redundancy equipment, fire containment equipment, and devices to protect personnel and equipment from operational mistakes.

DC to DC Converter Power IC MD1620F Application Manual Table of Contents

CONTENTS

1.	Using the MD1620F DC to DC Converter Power IC	1
2.	General description of the DC to DC Converter Power IC MD1620F	3
	2 – 1 Features	
	2 – 2 Applications	
	2 – 3 Nomenclature	
	2 – 4 Terminal functions	
	2 – 5 Peripheral functions	4
	2 – 6 Block diagrams	5
3.	External dimensions (Diagram)	6
4.	Characteristics	7
5.	Mounting	8
	5 – 1 Soldering pattern reference (Reflow-type)	
	5 – 2 Mounting cautions	9
	5 – 3 Printed circuit board patterns and design considerations (Reference)	
6.	Operating instructions	10
	6 – 1 Basic input and output connections	
	6 – 2 Input protection element connection	11
	6 – 3 Overvoltage protection	
	6 – 4 Reference parts	12
	6 – 5 Electrical characteristics	
7.	Basic design procedure	13
	7 – 1 Overcurrent detecting resistor (R1) selection	
	7 – 2 Inductance (L1) selection	
	7 – 3 Output capacitor selection	14
	7 – 4 Input capacitor selection	
	7 – 5 Thermal management	
8.	Electrical measurement data	15~16
	Output voltage - 5V	
9.	Packing conditions	17
	9 – 1 Taping type	
	9 – 2 Stick type	18
	9 – 3 Package configuration	
	9 – 4 Order quantity and dimensions	

2 General description of the DC to DC Converter Power IC MD1620F

The MD1620F is a non-isolated step-down DC to DC converter power IC. Main components are the MOSFET switch and the SBD flywheel. Maximum output is 10W (5V and 2A). The equipment is highly efficient and may be used for a wide range of applications.

HSOP-type surface mount packaging is used. Minimal external control circuitry is required. This permits a small footprint and low profile of power supply.

◆ 2 – 1 Features

- Input voltage range: 12~57V
- Output voltage: 5V
- Maximum output current: 2A
- Main switch MOSFET and built-in SBD flywheel
- Oscillation frequency: 250 kHz (Built-in oscillator does not require external capacitors or resistors)
- Overcurrent protection function
- Heat protection function
- Built-in low-voltage protection (UVLO) function

◆ 2 – 2 Applications

- Information distribution equipment
- Office automation equipment
- Electronic measuring instruments
- Home appliances
- Telecommunications equipment
- Factory automation equipment (Process control)
- Audio-video devices

◆ 2 – 3 Nomenclature

Device name and packaging specification codes are provided. Shipping conditions are determined according to these specifications.

Entry example: MD1620F 4072

Specification code: Shows package configuration and product name

◆ 2 – 4 Peripheral functions

1) Internal reference voltage (Vref)

IC internal circuitry reference voltage is provided by the temperature compensation reference voltage (5.0V). This reference voltage (Vref) provides a maximum external output current measured at the terminal of 1 mA.

2) Oscillation circuit (OSC)

The oscillation circuit is built into the device. No external oscillation capacitor nor resistor is required. The oscillation frequency (250 kHz) is set internally and has a sawtooth wave pattern. The sawtooth wave pattern cannot be outputted externally.

3) Error amplifier (Error Amp.)

The error amplifier senses the DC to DC converter voltage and provides a PWM control signal output. Loop gain between the error amplifier ampOUT terminal and the negative amp terminal is determined by the connections between the feedback resistor and the capacitor. This provides stable loop compensation throughout the system.

4) Overcurrent sensor (OCL)

The OCL is a pulse-by-pulse overcurrent sensor. The voltage drop across the external current sensing resistor is measured between the negative and positive terminals of the OCL. If the voltage drop exceeds $\cong 0.19V$, the main switch (MOSFET) opens.

◆ 2 – 5 Terminal functions

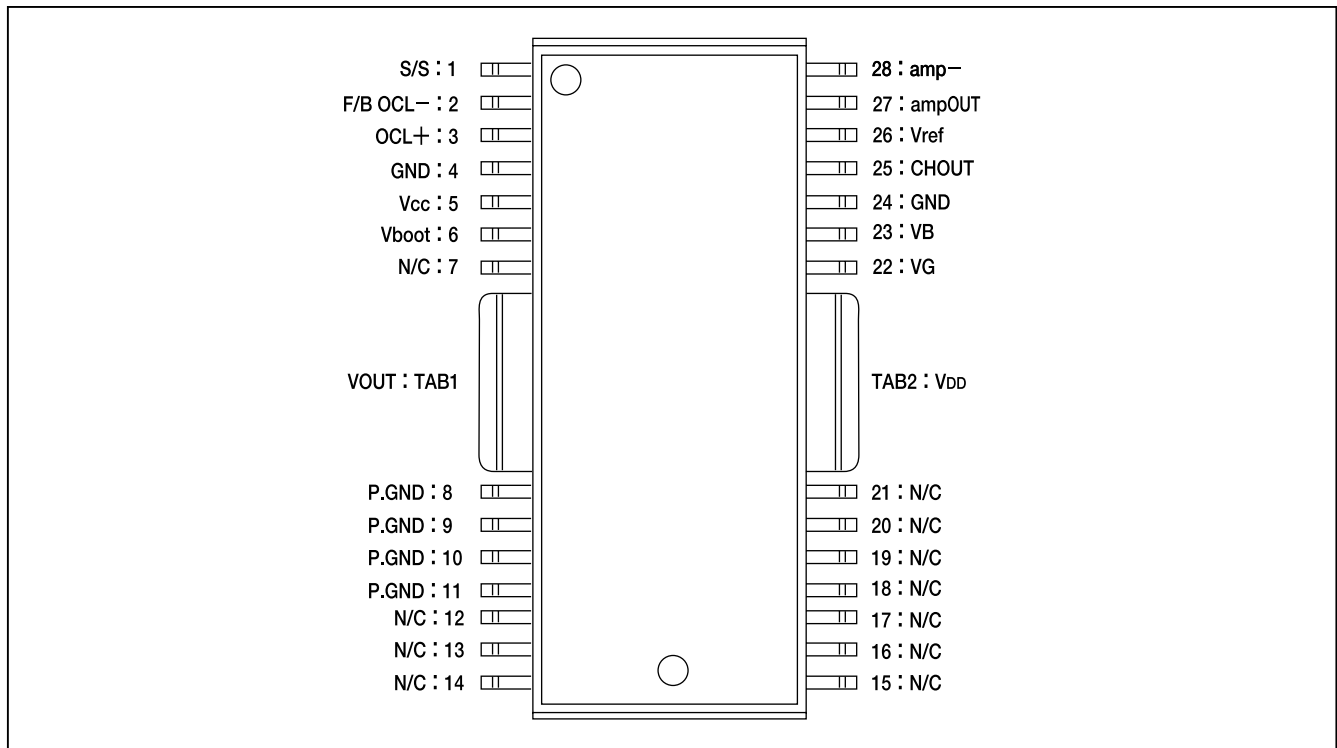

Terminal No.	Terminal symbol	Function
1	S/S	Soft-start capacitor terminal
2	F/B OCL-	Overcurrent detection terminal (-) /feedback terminal
3	OCL+	Overcurrent detection terminal (+)
4	GND	Ground terminal
5	Vcc	Control circuit power supply terminal
6	Vboot	Main switch MOSFET control circuit power supply terminal
7	N/C	Blank (=No connection) terminal
8~11	P.GND	Output circuit ground terminal
12~21	N/C	Blank (=No connection) terminal
22	VG	Main switch MOSFET gate terminal
23	VB	Output boot strap terminal used to connect the capacitor in the line between the VB terminal and the VOUT terminal and to regulate the IC internal main switch MOSFET control circuit
24	GND	Ground terminal
25	CHOUT	Output is regulated to 5.0V when switched to CHOUT "L" level terminal.
26	Vref	Internal reference voltage output terminal
27	ampOUT	Internal error amplifier output terminal
28	amp-	Internal error amplifier reversing input terminal
TAB1	VOUT	Power supply output terminal
TAB2	VDD	Main switch MOSFET current terminal

◆ 2 - 6 Block diagrams

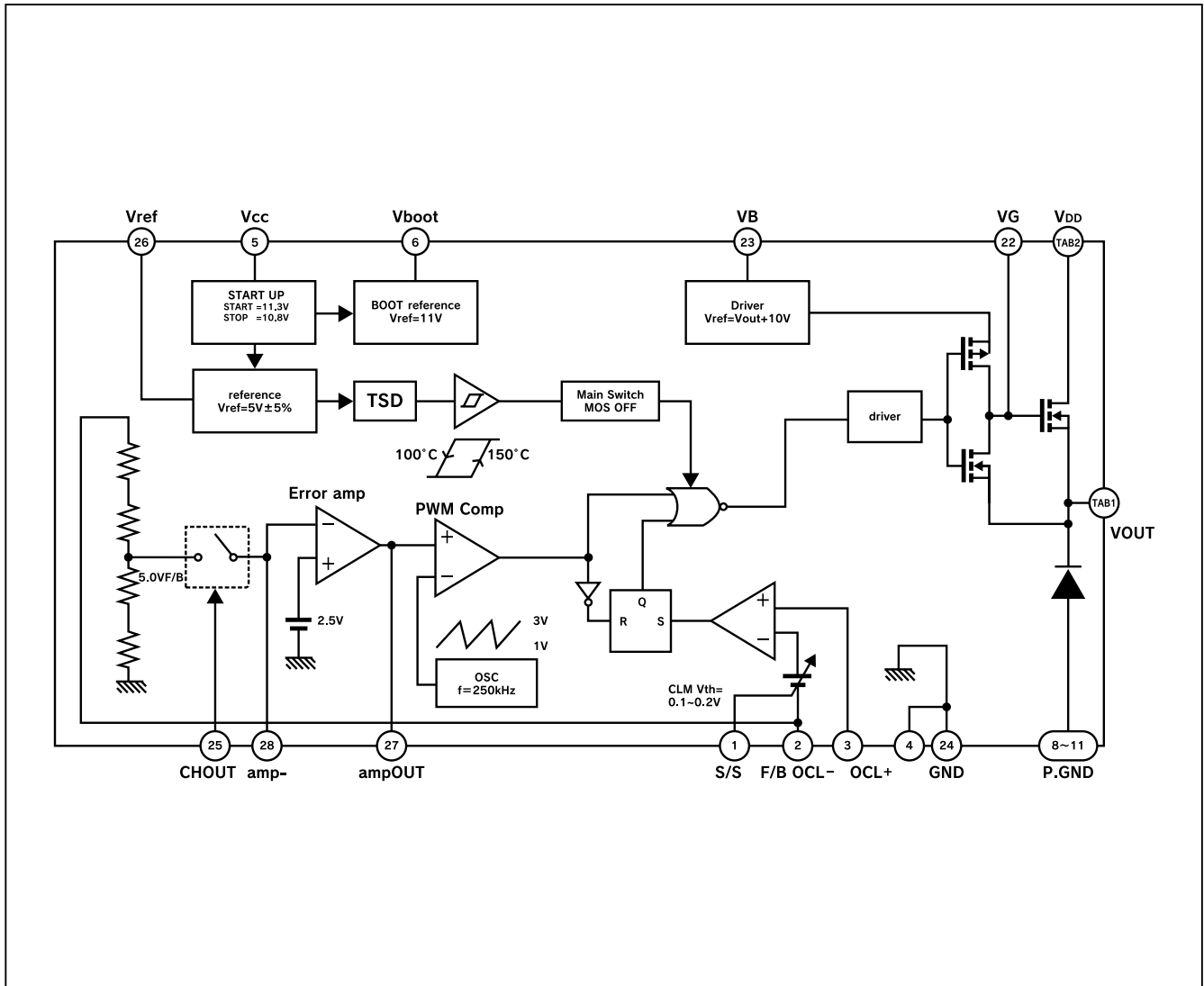

3 External dimensions (Diagram) (HSOP-28)

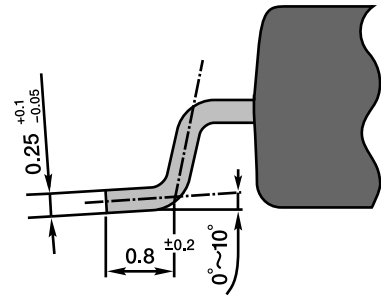
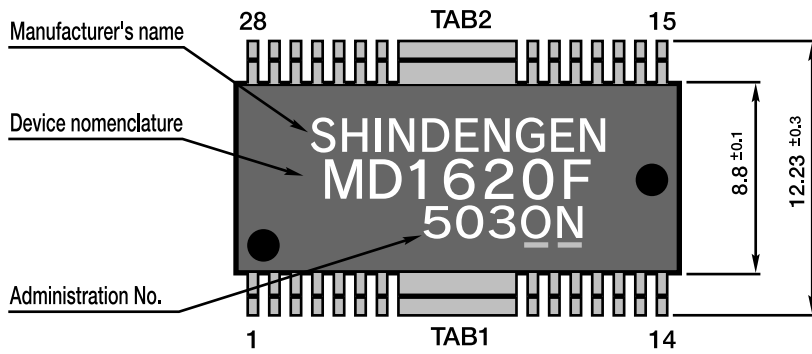

Detail (A) S=12/1

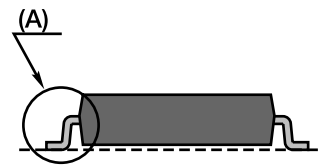
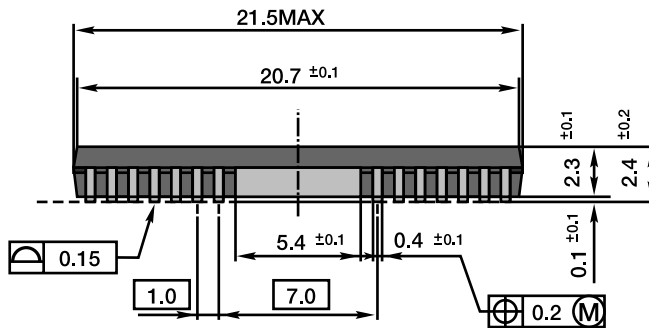

Unit: mm

4 Characteristics

1) Maximum rating (Ta=25 °C)

Item	Symbol	Rated value	Unit
Line voltage	V _{IN}	60	V
Output MOS input voltage	V _{DD}	60	V
Output current (AVE)	I _{OUTave}	2	A
Output current (PEAK)	I _{OUTpeak}	3	A
Storage temperature	T _{stg}	-40~150	°C
Junction temperature	T _j	150	°C

2) Recommended operating conditions

Item	Recommended value	Unit
Input voltage	12~57	V
Operating temperature	-10~80	°C

3) Electrical characteristics (Ta=25 °C)

Item	Symbol	Conditions	MIN	TYP	MAX	Unit
HighsideMOS Drain-source breakdown voltage	V _{dss}	I _D =1mA, V _{GS} =0V	60	—	—	V
HighsideMOS Drain interruption current	I _{dss}	V _{DS} =60V, V _{GS} =0V	—	—	10	μA
HighsideMOS Drain-source ON resistance	R _{on}	I _D =1.2A, V _{GS} =4V	—	270	550	mΩ
HighsideMOS Source-drain Di forward voltage	V _{SD}	I _S =1.2A, V _{DS} =0V	—	—	1.5	V
LowSideSBD Peak reverse voltage	V _{RM}	—	60	—	—	V
LowSideSBD Forward voltage	V _F	I _F =1.2A	—	—	0.58	V
LowSideSBD Reverse current	I _R	V _R =V _{RM}	—	—	2.5	mA
Start voltage	V _{cc_start}	—	10.5	11.25	11.9	V
Stop voltage	V _{cc_stop}	—	10	10.75	11.5	V
Start-stop voltage hysteresis	V _{cc_hys}	—	—	0.5	—	V
Current consumption	I _{cc}	V _{cc} =12~57V	—	11	13	mA
BOOT terminal voltage	V _{boot}	V _{cc} =12~57V	10	11	12.5	V
Internal reference voltage	V _{ref}	V _{cc} =12~57V	4.75	5	5.25	V
Internal oscillation frequency	f _{osc}	V _{cc} =48V	212.5	250	287.5	kHz
Overcurrent threshold voltage	V _{th_OCL}	V _{cc} =48V	0.162	0.19	0.218	V
SoftStart terminal current	I _{s/s}	V _{cc} =48V	-20	-12.5	-5	μA
Overcurrent protection operating temperature	T _{TSD}	—	—	150	—	°C

5 Mounting

◆ 5 – 1 Soldering pattern reference (Reflow-type)

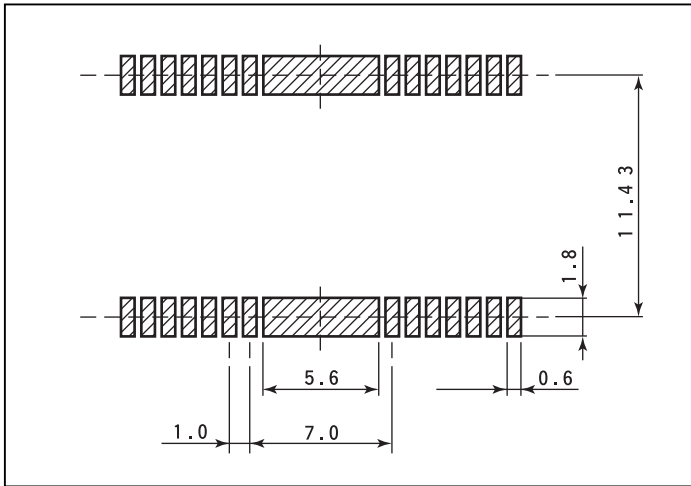

◆ 5 – 2 Mounting cautions

1) Mounting

Vibration and other mechanical disturbances can exert stress on the internal parts of the device. Carefully examine your equipment and place the device where vibration and other shock is minimal.

2) Soldering cautions

● Infrared reflow method

This method provides very high temperature soldering. The chart at the right shows the recommended temperature profiles for the Infrared reflow soldering method.

● Soldering iron

When using a soldering iron, observe the following.

Soldering iron temperature: Not to exceed 300°C

Soldering iron contact time: Not to exceed 10 seconds

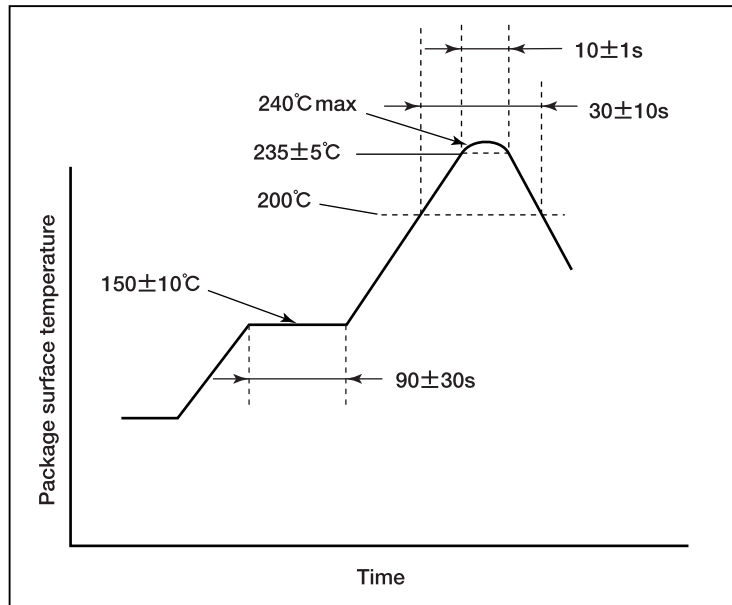

3) Cleaning cautions

Carefully remove all flux. Allow time for the soldered areas to completely dry before using the device.

4) Secondary mold cautions

After installation of the device to a board, remolding using plastic may be required. During this process, stress on the device will depend on the type of plastic used. The best plastic (that which causes the least stress on the device) has a minimum contraction ratio and high flexibility. Hardening temperatures should not exceed the storage temperature. Carefully check the plastic characteristics before use.

※ Static electricity can damage the device. The person and clothing of personnel working with the device should be grounded to prevent the build-up of static electricity. It is recommended that personnel stand on rubber mats (electrical safety mats) having a resistance greater than 1MΩ when working with the device. This will prevent damage to the device from static electricity discharge and protect the personnel from electrical shock.

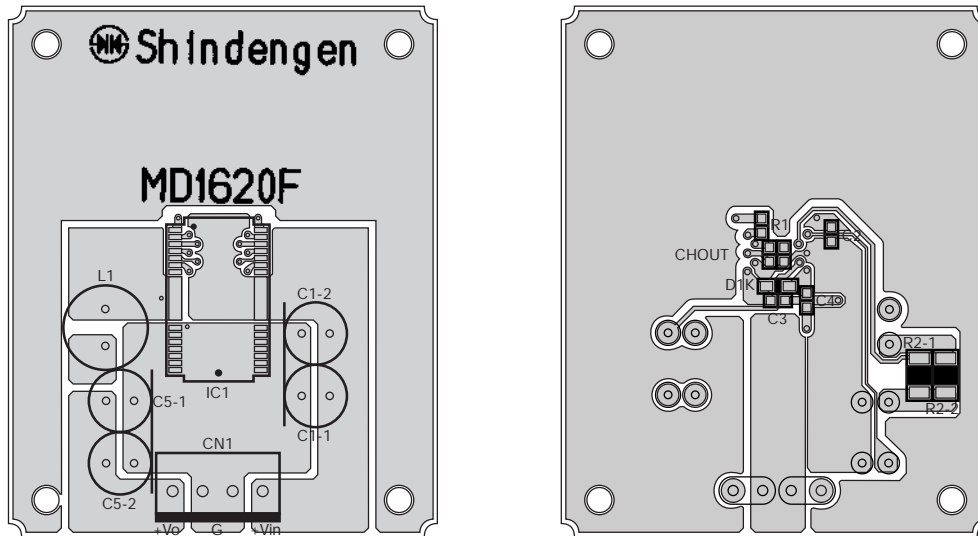

2A product model example

※ The device does not have a voltage surge protection circuit or an input fuse. The user should install an input fuse to protect the device and equipment before using the device.

- For optimum thermal efficiency, maintain the copper foil pattern as much as possible.
- Connect the F/B OCL negative terminal (Pin 2) as close as possible to the output capacitor (C5).
- Connect the input capacitor (C1), output capacitor (C5), choke (L1), and dropping resistor (R2) as close as possible to the power IC device.
- Separate the ground terminals (Pin 4 and Pin 24) and the P and ground terminals (Pins 8, 11). Connect each of them as close as possible to output capacitor (C5).

6 Operating instructions

The MD1620F power IC device uses chopper circuitry and can be referred to as a chopper type DC to DC converter. The device requires an external choke and capacitor to be connected to it. The characteristics of these external parts and the way they are packaged and connected will greatly affect the performance of the device and its circuits. Carefully select these external parts to provide optimum device performance. Neither the device input side nor output side is isolated.

◆ 6 – 1 Basic input and output terminal connections

Power IC device connection and use involves the rated output voltage and the maximum current output range.

- 1) Pin 25 must be connected to the ground terminal.
- 2) Pins 22 and 26 are the test terminal and must be left open.
- 3) Pins 7, 12, 13, 14, 15, 16, 17, 18, 19, 20, and 21 are internal non-connecting pins (N/C terminals).
- 4) Figure 6-1 shows the external parts and their connections. Be sure to prepare and connect these items before using the device.
- 5) Output capacitor (C5) minimizes switching frequency ripple and provides a smooth and stable output voltage. The use of a low-impedance capacitor is recommended (low impedance provides minimum ripple).

● Standard connections (Figure 6-1)

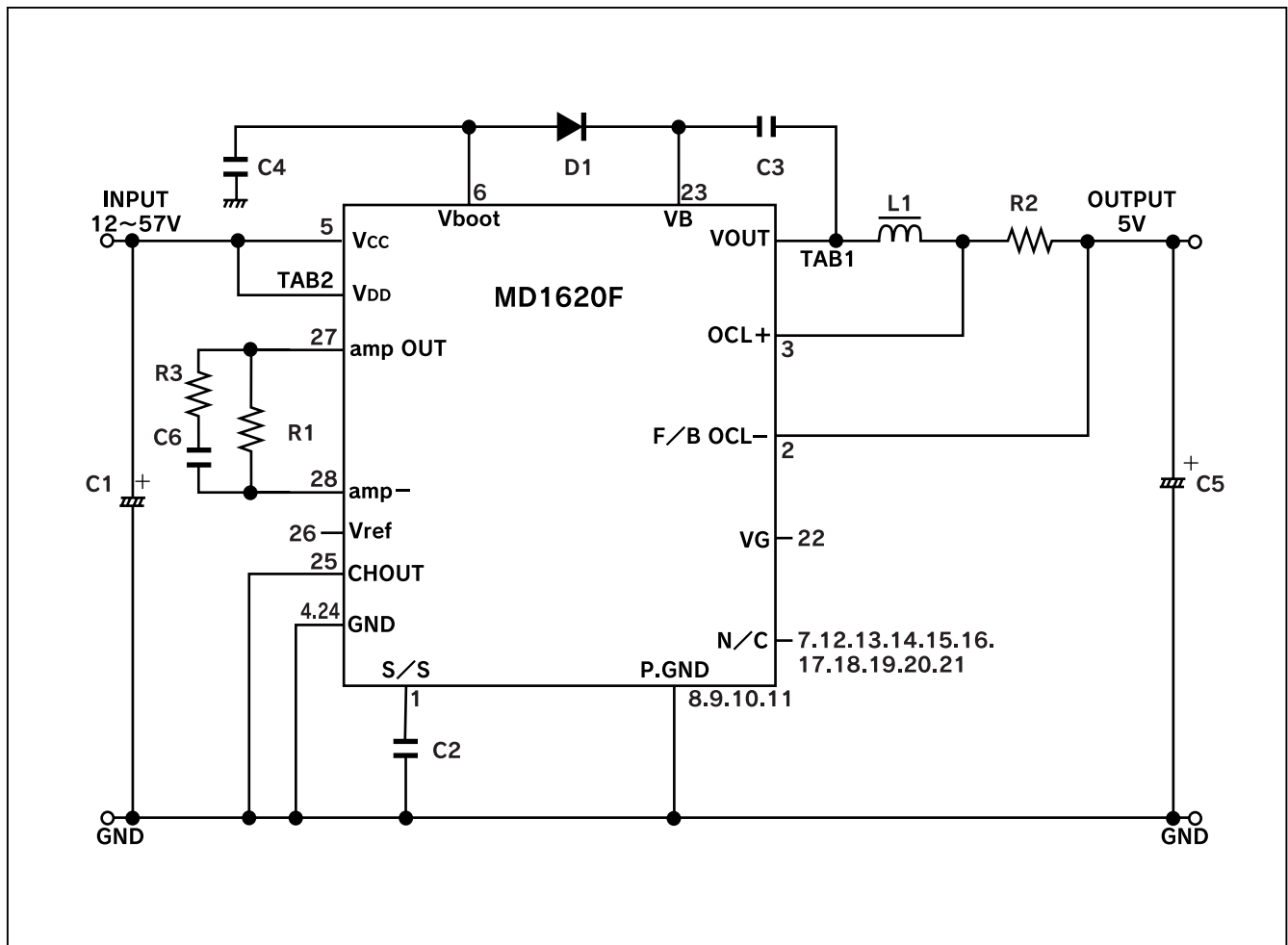

◆ 6 – 2 Input protection element connection

⚠ Caution

The MD1620F device has an output current drop function. In the event of power IC device malfunction resulting in excessive input current flow, smoke and flame may be emitted from the equipment. To prevent this, install a fuse or protective circuitry to the power IC device input line.

Install the fuse or protective circuitry to the positive side of the input line (Figure 6-2, DC input). Be sure that the fuse or protective circuitry is not too large to effectively protect the circuitry (the input line must be capable of carrying enough current to blow the fuse).

◆ 6 – 3 Overvoltage protection

The MD1620F power IC device does not have an overvoltage (voltage surge) protection function. If a malfunction occurs in the device internal circuitry, there may be a voltage surge. Output will reflect this surge and damage to equipment may result. Smoke and flame may be emitted from the equipment. To prevent this, be sure to install voltage surge sensing and protection circuitry.

There are a number of ways to protect against voltage surge. Figure 6-2 shows a typical voltage surge protection set-up. The voltage surge sensing and protection circuit should be installed as close as possible to the load (away from the output smoothing capacitor).

● Reference part example (Figure 6-2)

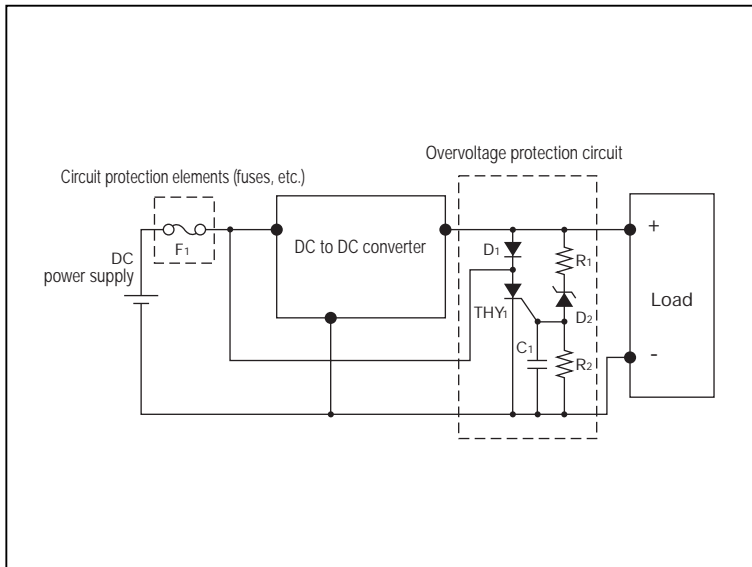

		5V
F 1	Circuit protection elements (fuses, etc.)	2A
R 1	Resistance	1/10 W 22 Ω
R 2	Resistance	1/10 W 1k Ω
C 1	Ceramic capacitor	CM316 334K 10AT 10V 0.33 μF
D 1	Diode	MIF L 20U 200V 1.1A
D 2	Zener diode	HZM5.6N B1 5.31~5.55V (5mA)
THY1	Thyristor	3P4J-Z 400V 3A

Conditions: At rated output current

◆ 6 – 4 Reference parts used with standard circuits

Part No.	Nomenclature	Output current example	
		1 A	2 A
L 1	Choke	68 μ H 1A	33 μ H 2A
D 1	Low-loss diode	M1FL20U(200V 1.1A)	M1FL20U(200V 1.1A)
C 1	Electrolyte capacitor	63V 220 μ F 531mA	63V 220 μ F 531mA \times 2
C 2	Ceramic capacitor	25V 0.01 μ F	25V 0.01 μ F
C 3	Ceramic capacitor	25V 0.01 μ F	25V 0.01 μ F
C 4	Ceramic capacitor	25V 0.1 μ F	25V 0.1 μ F
C 5	Electrolyte capacitor	10V 680 μ F 56m Ω	10V 1000 μ F 38m Ω
C 6	Ceramic capacitor	—	25V 1000pF
R 1	Resistance	0.1W 330k Ω	0.1W 330k Ω
R 2	Resistance	0.75W 0.15 Ω \pm 5%	0.75W 0.15 Ω \pm 5% \times 2
R 3	Resistance	—	0.1W 100k Ω

◆ 6 – 5 Electrical characteristics (Ta = 25 $^{\circ}$ C)

Efficiency and ripple are measured according to external reference parts circuit configuration that is based on standard circuit configuration.

Item	Output current example	
	1A	2A
Output voltage (V)	5	
Input voltage (V)	12~57	
Output current (A)	0~1	0~2
Voltage regulation accuracy (%)	\pm 5	
Efficiency Typ. (%)	77	78
Oscillation frequency Typ. (kHz)	250	
Ripple voltage p-p Typ. (mV)	25	
Overcurrent protection	Operated at rated current, min./automatic return	
Thermal protection Typ. ($^{\circ}$ C)	150	
Operating (ambient) temperature ($^{\circ}$ C)	-10~80	

Efficiency and ripple voltage conditions: Vin = 48V and Io = rated output current

7 Basic device set-up standards

Set-up sequence below

Areas that must be carefully considered in the set-up of the device include the overcurrent detecting resistor, circuit inductance, output capacitor, input capacitor, and thermal characteristics.

◆ 7 – 1 Overcurrent detecting resistor (R1) selection

Detects a peak voltage across the resistor of $0.19V \pm 15\%$

$$R1 = \frac{V_R}{I_R} [\Omega]$$

※ Switching noise and other factors may cause some variation in the calculated drop point value. Check your own equipment and calculate the value accordingly.

V_R = Average voltage level

I_O = Output current

I_R = Drop point

◆ 7 – 2 Inductance (L1) selection

The selected inductance sets the cut-off current at 15% of the rated output current.

$$L1 = \frac{(V_i(\max) - V_o) \times (V_o + V_F)}{\Delta I \times (V_i(\max) + V_F) \times f} [H]$$

$V_i(\max)$ = Maximum input voltage

V_o : Output voltage

V_F : SBD flywheel forward voltage (0.5V)

ΔI : Cut-off current $\times 2$ ($I_o \times 0.15 \times 2$) (Cut-off current flows through the choke coil. Current value is intermittent.)

f : Oscillation frequency (250 kHz)

Calculated inductance values (L1) shown here represent those used in previously manufactured devices and may not be applicable to your device. The use of an actual value somewhat higher than the measured value is standard procedure. However, actual values lower than the measured value may be used where the rated current is low. Use the formula to back-calculate the ΔI using the selected L1 value. The recommended value is $0.2 \times I_o \leq \Delta I \leq 0.4 \times I_o$ (Cut-off at 10 to 20 percent).

◆ 7 – 3 Output capacitor selection

If an electrolytic capacitor is used, output ripple is determined by ΔI and capacitor impedance. Use the formula below to calculate the value. Select a device providing an impedance (Z_c) lower than the calculated value.

$$Z_c \leq \frac{V_{rip}}{\Delta I} [\Omega]$$

V_{rip} : Output ripple voltage (Ex: 25m V_{P-P})

ΔI : Cut-off current $\times 2$

◆ 7 – 4 Input capacitor selection

A large ripple current flows through the input capacitor. Use the formula below to calculate the value. Select a device providing a higher ripple current capacity (I_{rip}) than the calculated value.

$$D = \frac{V_o + V_F}{V_i (\text{min}) + V_F}$$

$$I_{rip} \geq \sqrt{D(1-D)} \times I_o [H]$$

D : Duty

V_o : Output voltage

$V_i (\text{min})$: Minimum input voltage

V_F : SBD flywheel forward voltage (0.5V)

◆ 7 – 5 Thermal management

The MD1620F device has a TAB1 - TAB2 substrate connection pattern to provide optimum heat dissipation.

Required heat dissipation pattern area varies with substrate thickness, substrate material, and substrate size. Refer to the data in Figure 7-1. Configure your own equipment accordingly.

Temperature increase varies with input voltage, output voltage, and output current. Case surface temperatures should not exceed 105°C . Set-up your equipment accordingly.

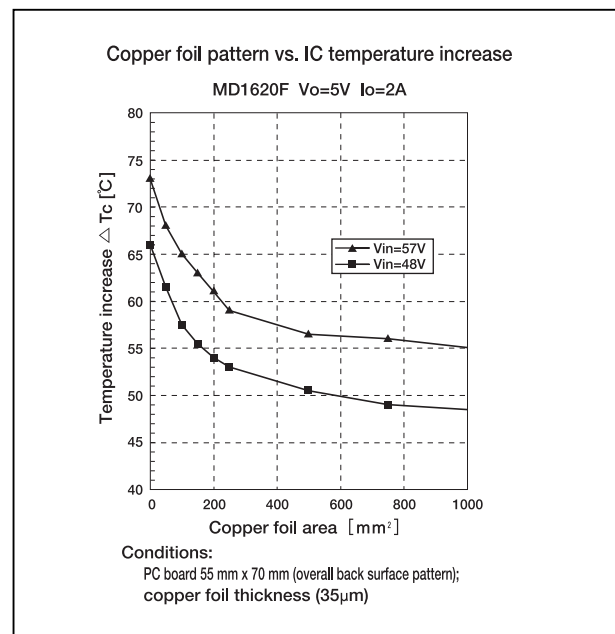

Figure 7-1

8 Electrical data measurement

This data results from measurements taken using equipment connected as shown in the standard connection diagram and using reference part and reference circuitry patterns.

Output voltage - 5V

● Line regulation

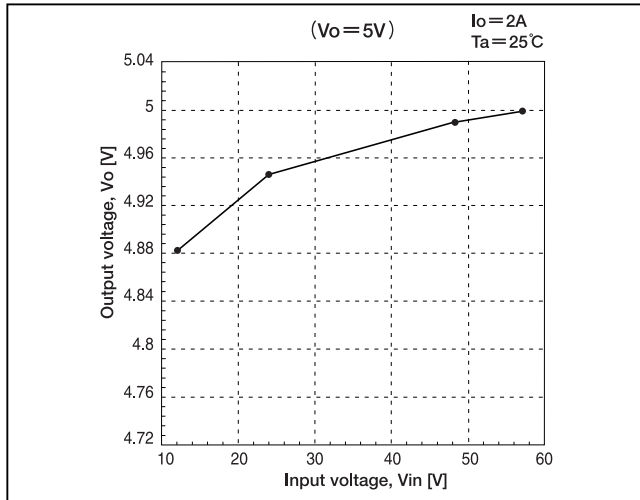

● Load regulation

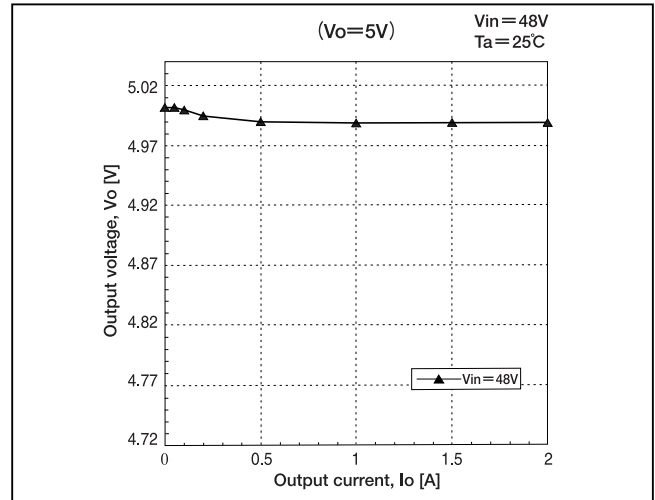

● Temperature drift

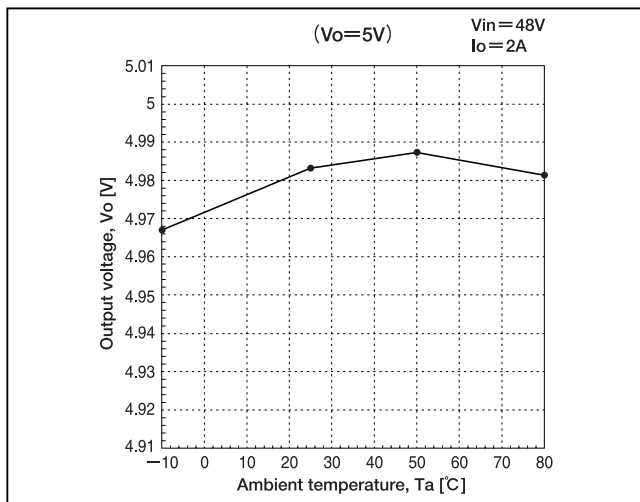

● Efficiency and loss characteristics

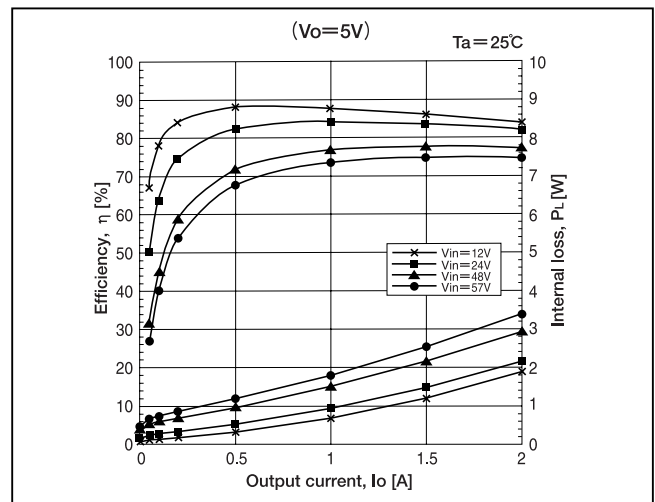

● IC temperature increase

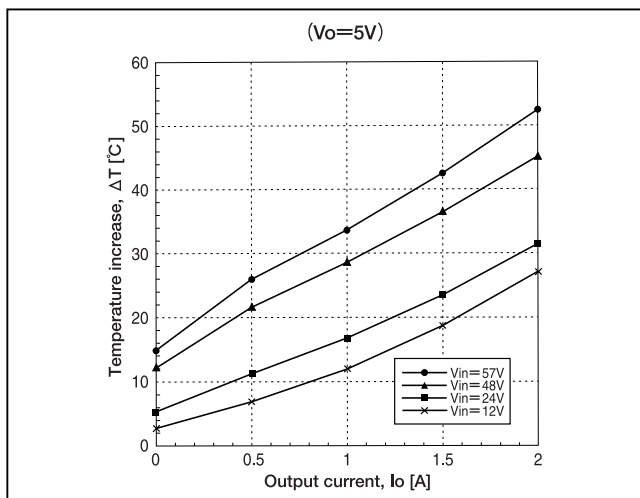

● Derating curve

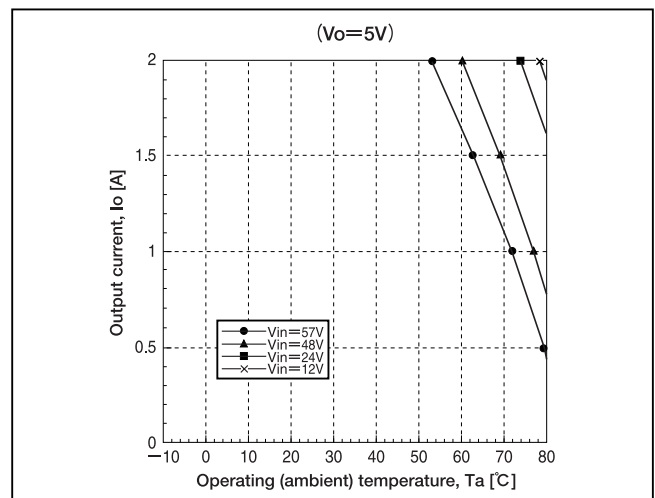

● Input current/input voltage characteristics

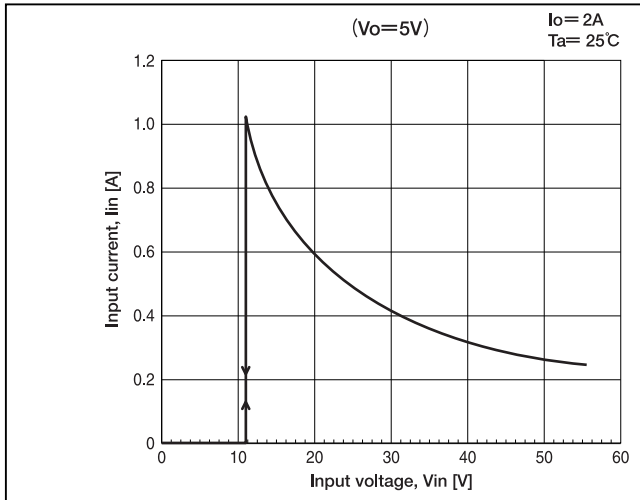

● Input voltage/output voltage characteristics

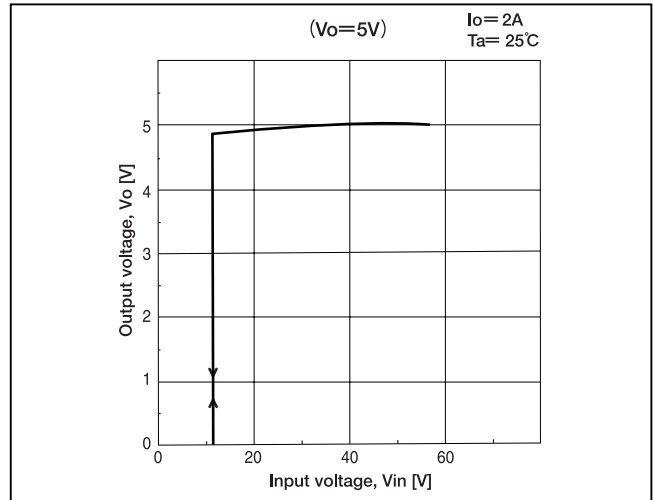

● Current limit characteristic (Input fluctuation)

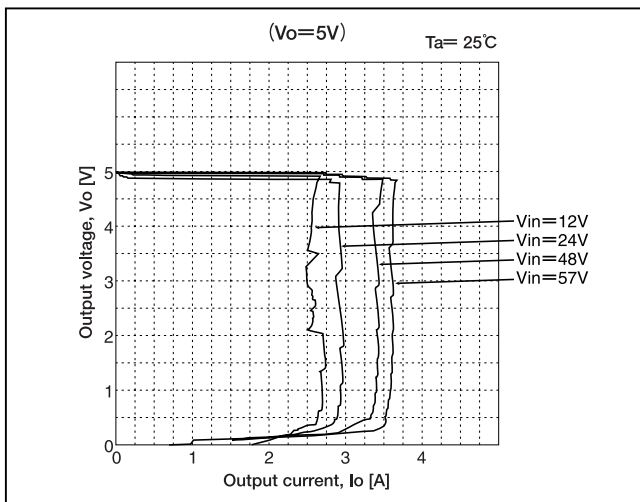

● Current limit characteristic (Temperature fluctuation)

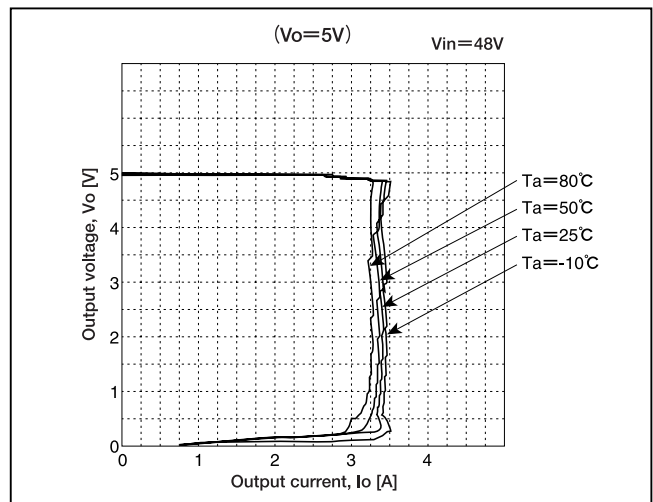

● Start-up rising characteristics

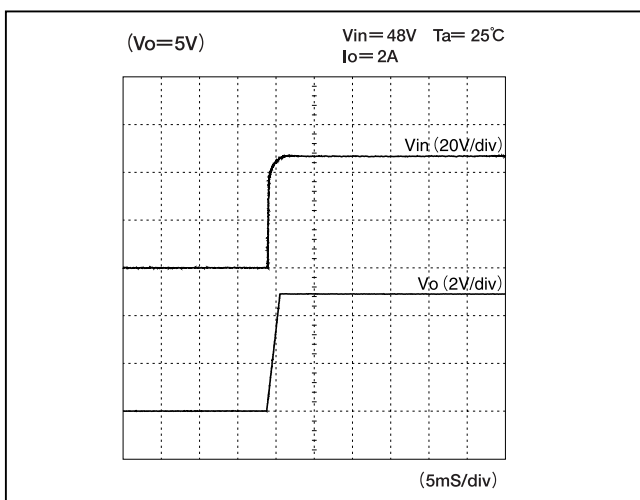

● Shut-down falling characteristics

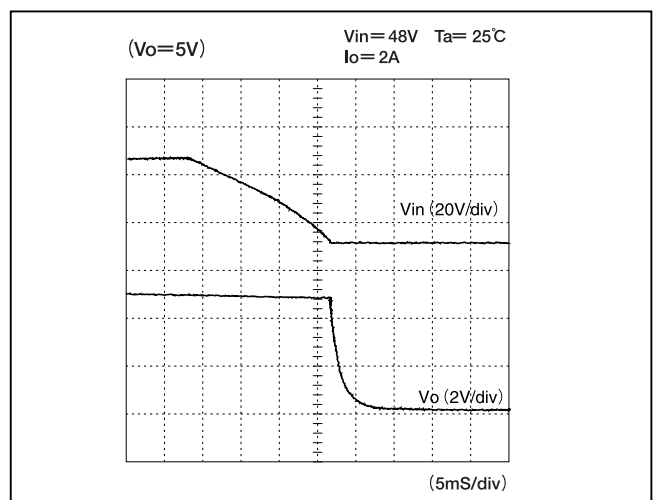

9 Packing

◆ 9 – 1 Tape & Reel

1) Tape

- Material : PVC
- Dimensions Comply with JIS, C-0806

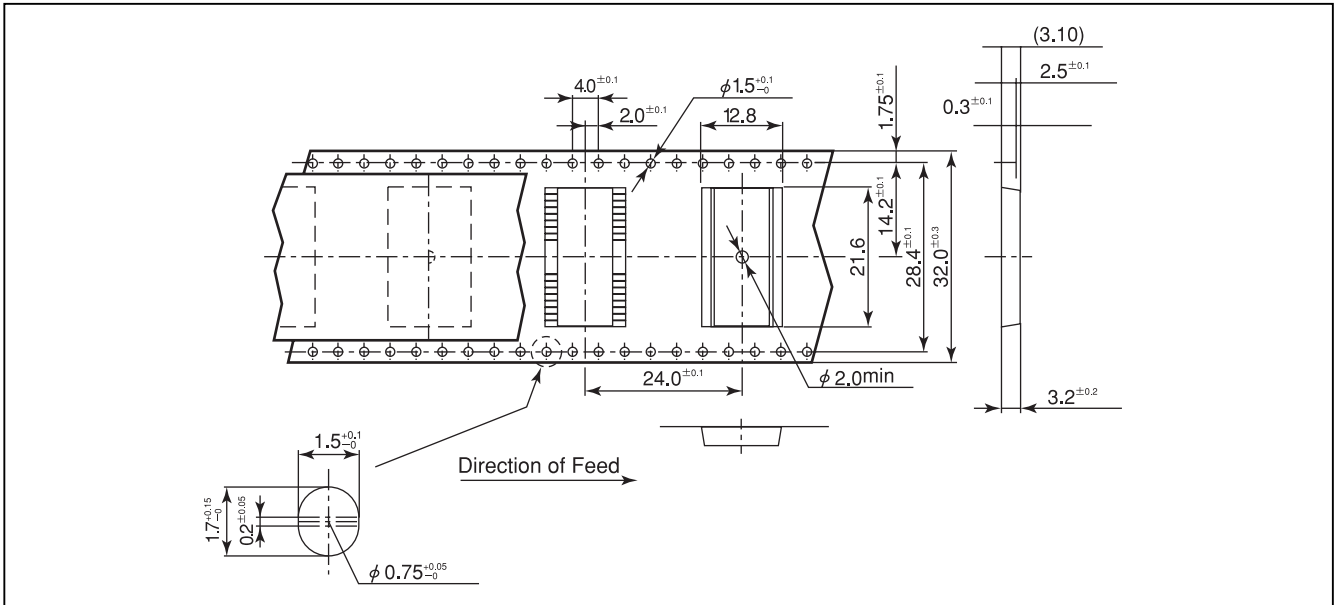

2) Reel

- Material : Polystyrene
- Dimensions Comply with EIAJ, ETX-7001

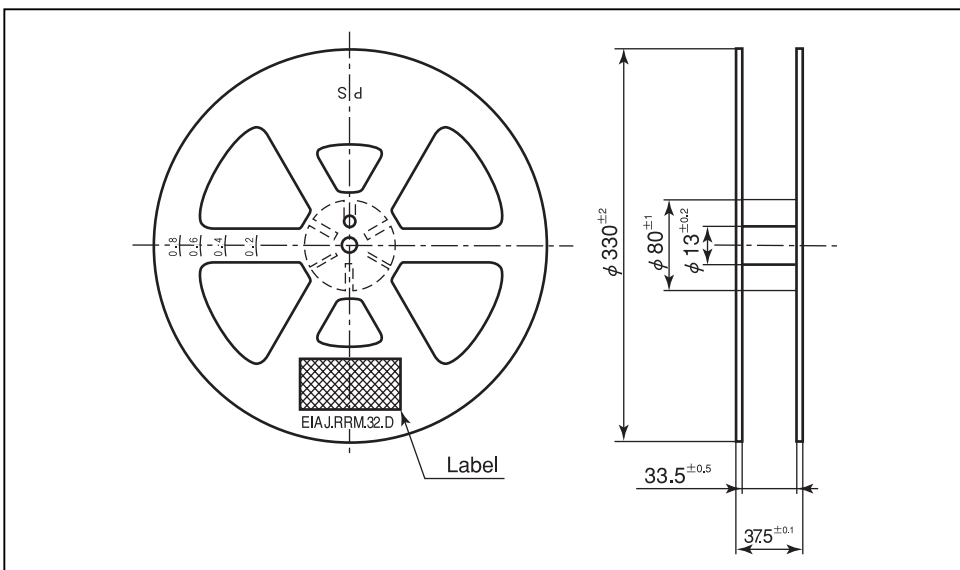

• Label

- Type No.
- Class
- Code No.
- Date Code
- Quantity
- Manufacturer

3) Leader and Trailer

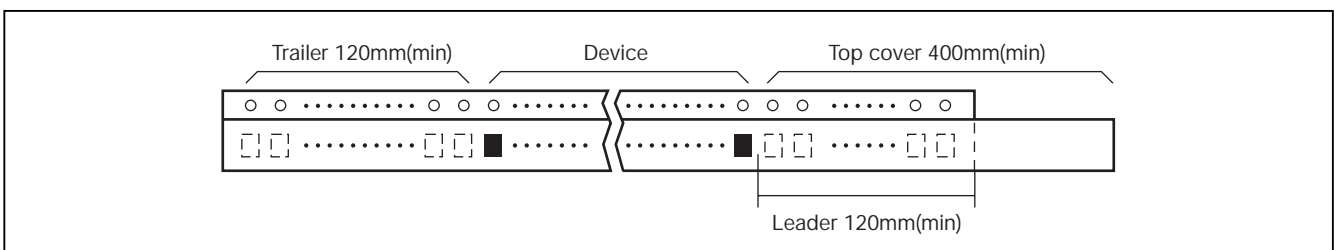

◆ 9 – 2 Stick

· Capacity : 25pcs / 1 stick

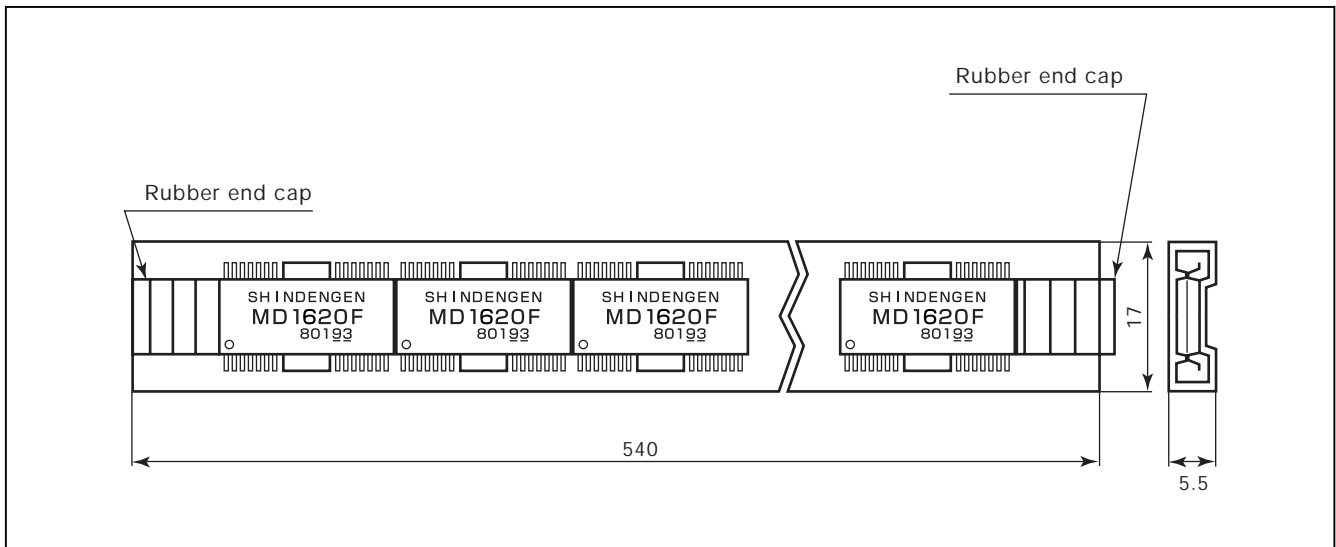

◆ 9 – 3 Packing

· Tape & Reel : 3,000pcs (3 Reels) / Outer Carton

· Stick : 4,000pcs (160 Sticks) / Outer Carton

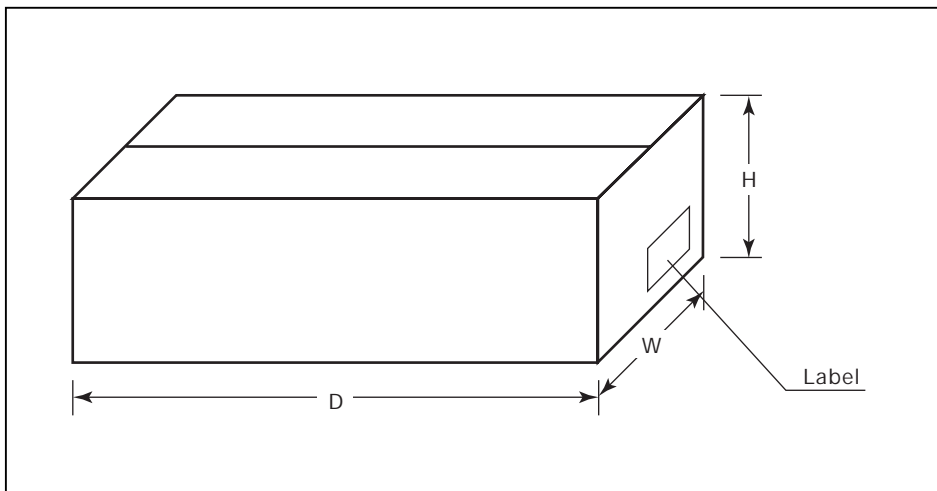

· Marking

Type No. · Code No. · Date Code · Quantities

◆ 9 – 4 Ordering and Dimensions

Package	Code No.	Minimum Ordering Quantities			Quantities Per Inner Carton (pcs.)	Quantities per Outer Carton		Outer Carton (mm)		
		Quantities	Stick	Taping		pcs./Carton	Weight(kg)	D	W	H
HSOP-28	4072	1000		○	1000	3000	7.6	363	363	160
	4102	25	○		500	4000	9.6	571	173	156

** Specifications are subject to change without notice.*



SHINDENGEN ELECTRIC MFG. CO., LTD.

RECRUIT Ikebukuro Bldg., 13-23, 1-chome Minami-Ikebukuro, Toshima-ku, Tokyo 171-0022 Japan
Phone:03-5951-8106 Facsimile:03-5951-8090