

*Designer's™ Data Sheet*  
**SCANSWITCH™**  
**NPN Bipolar Power Deflection Transistor**  
**For High and Very High Resolution Monitors**

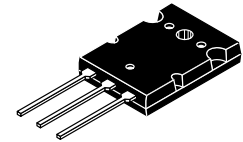
The MJL16218 is a state-of-the-art SWITCHMODE™ bipolar power transistor. It is specifically designed for use in horizontal deflection circuits for 20 mm diameter neck, high and very high resolution, full page, monochrome monitors.

- 1500 Volt Collector–Emitter Breakdown Capability
- Typical Dynamic Desaturation Specified (New Turn–Off Characteristic)
- Application Specific State–of–the–Art Die Design
- Fast Switching:
  - 175 ns Inductive Fall Time (Typ)
  - 2000 ns Inductive Storage Time (Typ)
- Low Saturation Voltage:
  - 0.2 Volts at 5.0 Amps Collector Current and 2.0 A Base Drive
- Low Collector–Emitter Leakage Current — 250  $\mu$ A Max at 1500 Volts —  $V_{CES}$
- High Emitter–Base Breakdown Capability For High Voltage Off Drive Circuits — 8.0 Volts (Min)

**MJL16218\***

\*Motorola Preferred Device

**POWER TRANSISTOR**  
**15 AMPERES**  
**1500 VOLTS —  $V_{CES}$**   
**170 WATTS**



**CASE 340G–02, STYLE 2**  
**TO–3PBL**

**MAXIMUM RATINGS**

Rating	Symbol	Value	Unit
Collector–Emitter Breakdown Voltage	$V_{CES}$	1500	Vdc
Collector–Emitter Sustaining Voltage	$V_{CEO(sus)}$	650	Vdc
Emitter–Base Voltage	$V_{EBO}$	8.0	Vdc
Collector Current — Continuous	$I_C$	15	Adc
— Pulsed (1)	$I_{CM}$	20	
Base Current — Continuous	$I_B$	7.0	Adc
— Pulsed (1)	$I_{BM}$	14	
Maximum Repetitive Emitter–Base Avalanche Energy	W (BER)	0.2	mJ
Total Power Dissipation @ $T_C = 25^\circ\text{C}$	$P_D$	170	Watts
@ $T_C = 100^\circ\text{C}$		39	
Derated above $T_C = 25^\circ\text{C}$		1.49	W/ $^\circ\text{C}$
Operating and Storage Temperature Range	$T_J, T_{stg}$	– 55 to 125	$^\circ\text{C}$

**THERMAL CHARACTERISTICS**

Characteristic	Symbol	Max	Unit
Thermal Resistance — Junction to Case	$R_{\theta JC}$	0.67	$^\circ\text{C}/\text{W}$
Lead Temperature for Soldering Purposes 1/8" from the case for 5 seconds	$T_L$	275	$^\circ\text{C}$

- (1) Pulse Test: Pulse Width = 5.0 ms, Duty Cycle  $\leq$  10%.  
(2) Proper strike and creepage distance must be provided.

Designer's and SCANSWITCH are trademarks of Motorola, Inc.

**Designer's Data for "Worst Case" Conditions** — The Designer's Data Sheet permits the design of most circuits entirely from the information presented. SOA Limit curves — representing boundaries on device characteristics — are given to facilitate "worst case" design.

**Preferred** devices are Motorola recommended choices for future use and best overall value.

# MJL16218

## ELECTRICAL CHARACTERISTICS ( $T_C = 25^\circ\text{C}$ unless otherwise noted)

Characteristic	Symbol	Min	Typ	Max	Unit
<b>OFF CHARACTERISTICS (2)</b>					
Collector Cutoff Current ( $V_{CE} = 1500\text{ V}, V_{BE} = 0\text{ V}$ ) ( $V_{CE} = 1200\text{ V}, V_{BE} = 0\text{ V}$ )	$I_{CES}$	—	—	250 25	$\mu\text{A}_{dc}$
Emitter–Base Leakage ( $V_{EB} = 8.0\text{ V}_{dc}, I_C = 0$ )	$I_{EBO}$	—	—	25	$\mu\text{A}_{dc}$
Emitter–Base Breakdown Voltage ( $I_E = 1.0\text{ mA}, I_C = 0$ )	$V_{(BR)EBO}$	8.0	11	—	Vdc
Collector–Emitter Sustaining Voltage (Table 1) ( $I_C = 10\text{ mA}_{dc}, I_B = 0$ )	$V_{CEO(sus)}$	650	—	—	Vdc

## ON CHARACTERISTICS (2)

Collector–Emitter Saturation Voltage ( $I_C = 5.0\text{ A}_{dc}, I_B = 2.0\text{ A}_{dc}$ ) ( $I_C = 3.0\text{ A}_{dc}, I_B = 0.6\text{ A}_{dc}$ )	$V_{CE(sat)}$	—	0.17 0.14	1.0 0.5	Vdc
Base–Emitter Saturation Voltage ( $I_C = 5.0\text{ A}_{dc}, I_B = 1.0\text{ A}_{dc}$ )	$V_{BE(sat)}$	—	0.9	1.5	Vdc
DC Current Gain ( $I_C = 1.0\text{ A}, V_{CE} = 5.0\text{ V}_{dc}$ ) ( $I_C = 12\text{ A}, V_{CE} = 5.0\text{ V}_{dc}$ )	$h_{FE}$	— 4.0	24 6.0	— —	—

## DYNAMIC CHARACTERISTICS

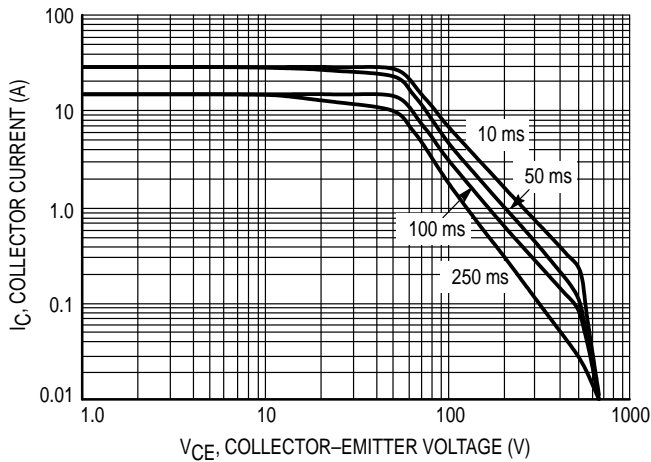
Dynamic Desaturation Interval ( $I_C = 5.5\text{ A}, I_{B1} = 2.2\text{ A}, LB = 1.5\text{ }\mu\text{H}$ )	$t_{ds}$	—	350	—	ns
Output Capacitance ( $V_{CE} = 10\text{ V}_{dc}, I_E = 0, f_{test} = 100\text{ kHz}$ )	$C_{ob}$	—	300	500	pF
Gain Bandwidth Product ( $V_{CE} = 10\text{ V}_{dc}, I_C = 0.5\text{ A}, f_{test} = 1.0\text{ MHz}$ )	$f_T$	—	0.8	—	MHz

## SWITCHING CHARACTERISTICS

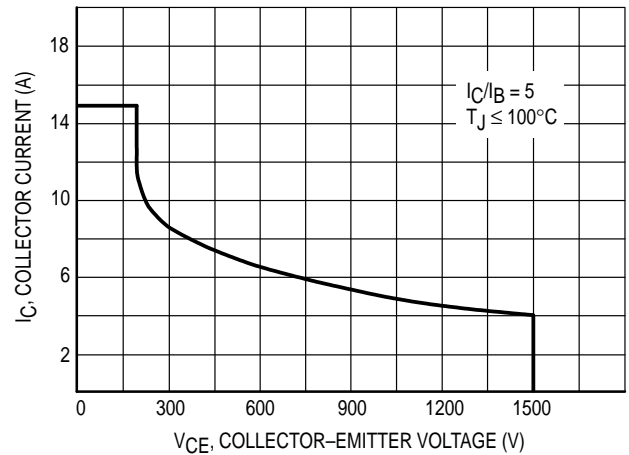
Inductive Load ( $I_C = 6.0\text{ A}, I_B = 2.0\text{ A}$ ), High Resolution Deflection Simulator Circuit Table 2					ns
Storage	$t_{sv}$	—	2000	3000	
Fall Time	$t_{fj}$	—	175	250	

(2) Pulse Test: Pulse Width = 300  $\mu\text{s}$ , Duty Cycle  $\leq 2.0\%$ .

## SAFE OPERATING AREA



**Figure 1. Maximum Forward Bias Safe Operating Area**



**Figure 2. Maximum Reverse Bias Safe Operating Area**

SAFE OPERATING AREA (continued)

FORWARD BIAS

There are two limitations on the power handling ability of a transistor: average junction temperature and second breakdown. Safe operating area curves indicate  $I_C - V_{CE}$  limits of the transistor that must be observed for reliable operation; i.e., the transistor must not be subjected to greater dissipation than the curves indicate.

The data of Figure 1 is based on  $T_C = 25^\circ\text{C}$ ;  $T_{J(pk)}$  is variable depending on power level. Second breakdown pulse limits are valid for duty cycles to 10% but must be derated when  $T_C \geq 25^\circ\text{C}$ . Second breakdown limitations do not derate the same as thermal limitations. Allowable current at the voltages shown on Figure 1 may be found at any case temperature by using the appropriate curve on Figure 3.

At high case temperatures, thermal limitations will reduce the power that can be handled to values less than the limitations imposed by second breakdown.

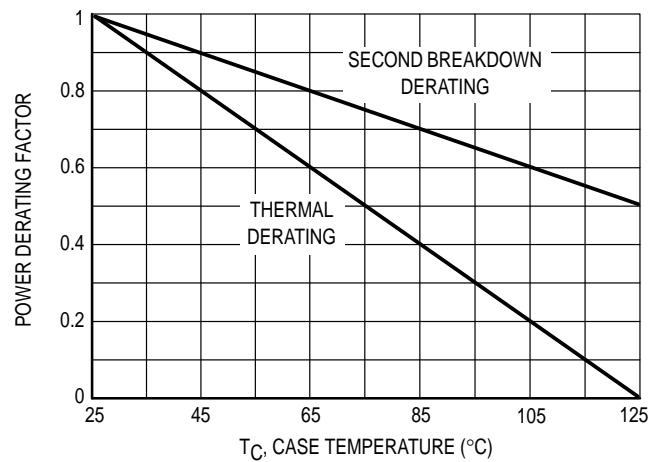


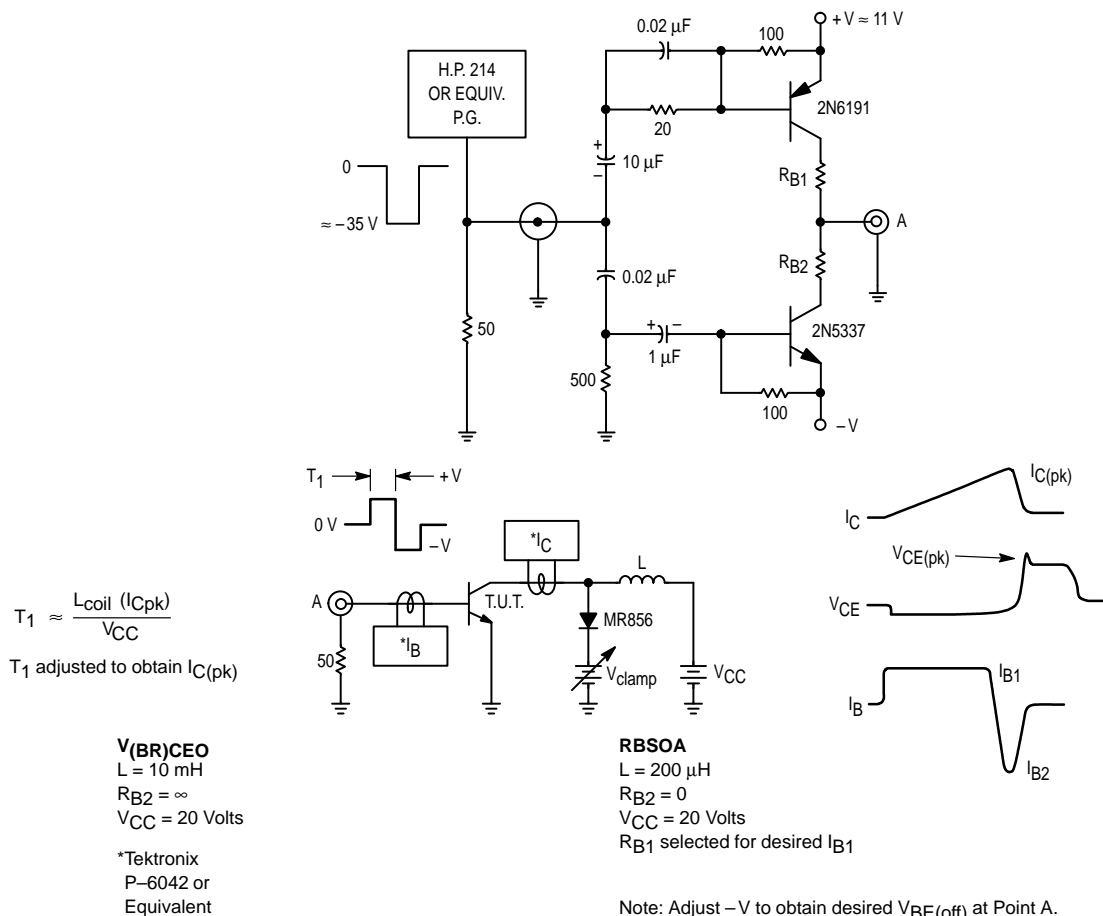
Figure 3. Power Derating

REVERSE BIAS

For inductive loads, high voltage and high current must be sustained simultaneously during turn-off, in most cases, with the base-to-emitter junction reverse biased. Under these conditions the collector voltage must be held to a safe level at or below a specific value of collector current. This can be accomplished by several means such as active clamping, RC snubbing, load line shaping, etc.

The safe level for these devices is specified as Reverse Biased Safe Operating Area and represents the voltage-current condition allowable during reverse biased turnoff. This rating is verified under clamped conditions so that the device is never subjected to an avalanche mode. Figure 2 gives the RBSOA characteristics.

Table 1. RBSOA/V(BR)CEO(SUS) Test Circuit



TYPICAL ELECTRICAL CHARACTERISTICS

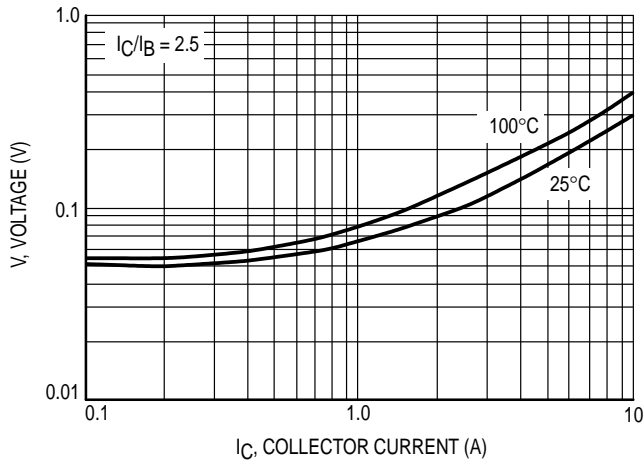


Figure 4. Typical Collector–Emitter Saturation Voltage

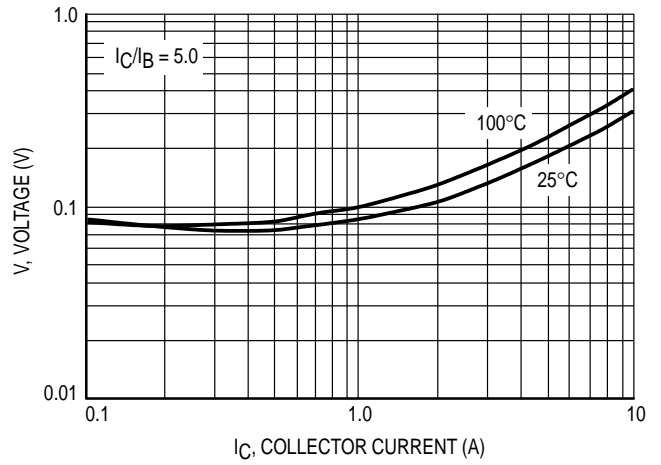


Figure 5. Typical Collector–Emitter Saturation Voltage

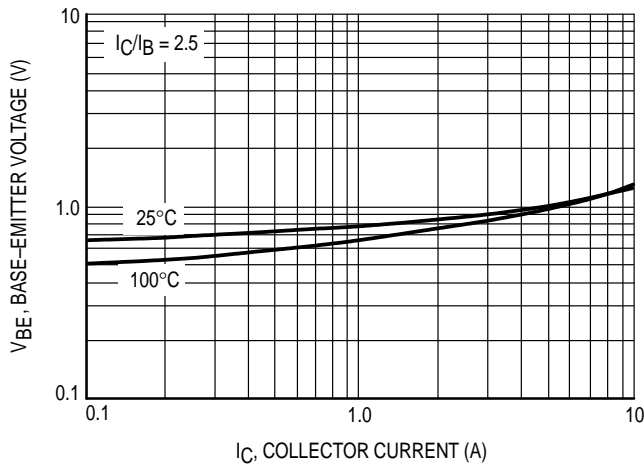


Figure 6. Typical Emitter–Base Saturation Voltage

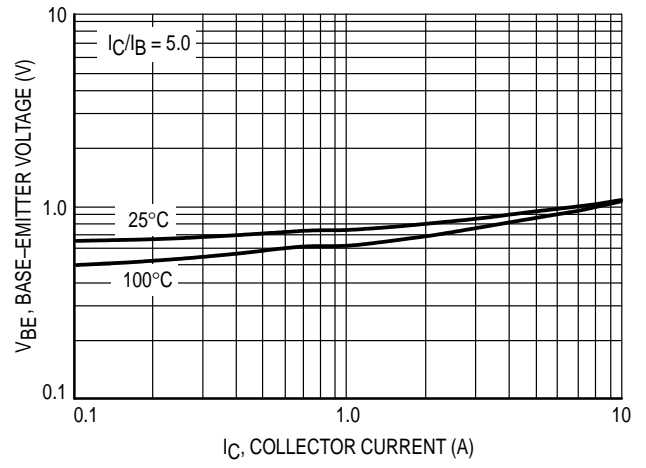


Figure 7. Typical Emitter–Base Saturation Voltage

TYPICAL ELECTRICAL CHARACTERISTICS (continued)

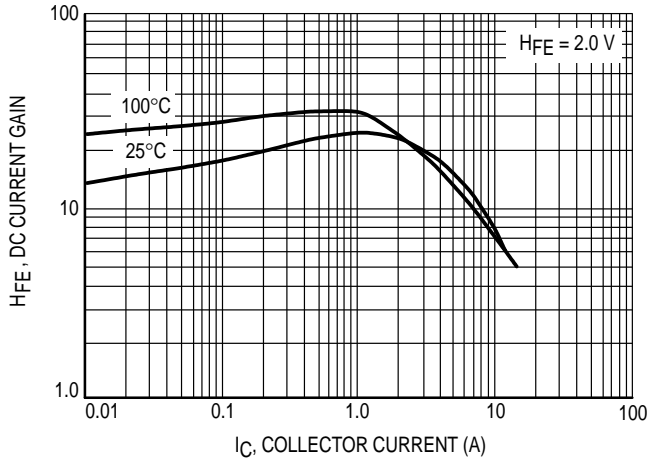


Figure 8. DC Current Gain

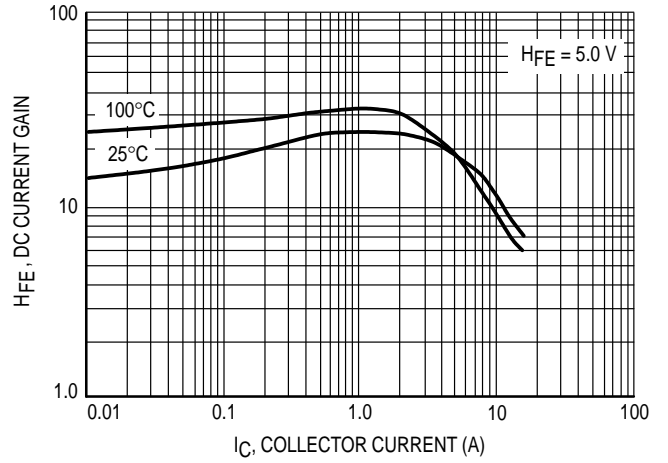


Figure 9. DC Current Gain

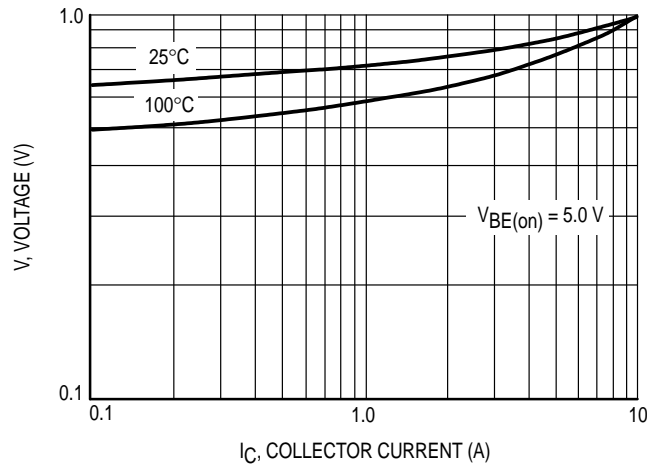
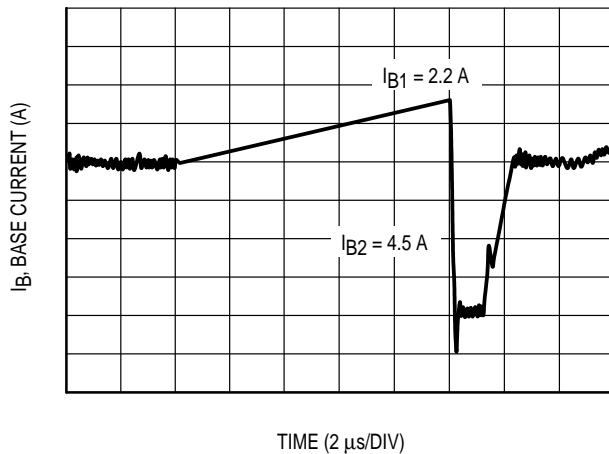
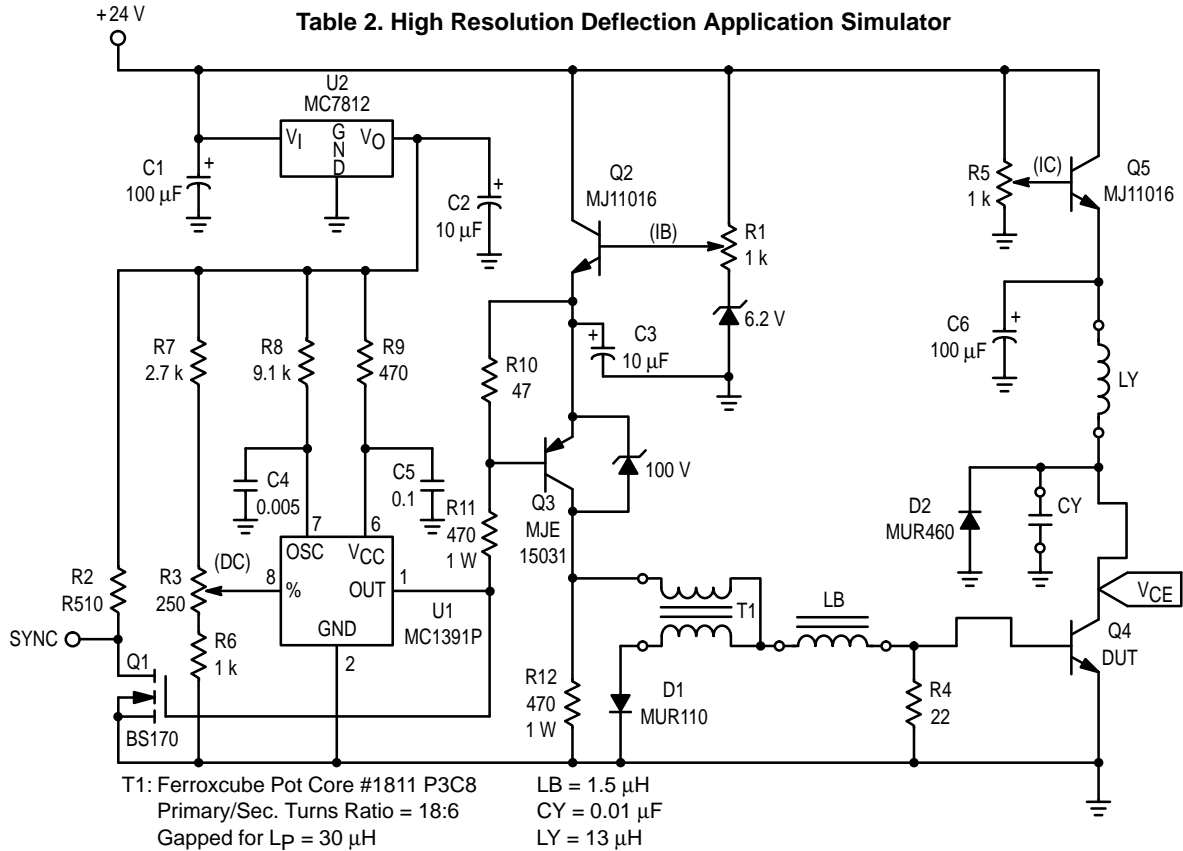


Figure 10. "On" Voltages

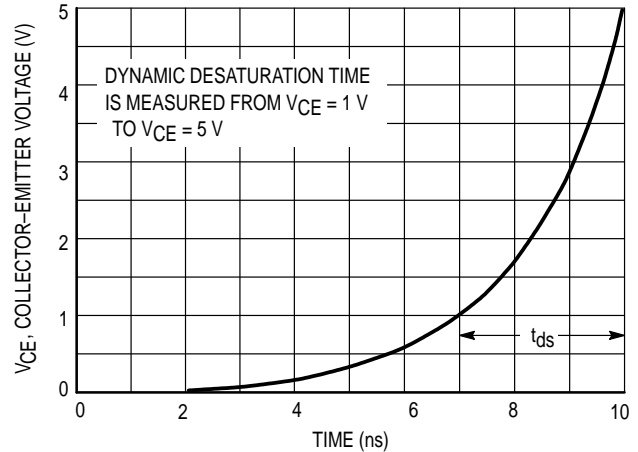
DYNAMIC DESATURATION

The SCANSWITCH series of bipolar power transistors are specifically designed to meet the unique requirements of horizontal deflection circuits in computer monitor applications. Historically, deflection transistor design was focused on minimizing collector current fall time. While fall time is a valid figure of merit, a more important indicator of circuit performance as scan rates are increased is a new characteristic, "dynamic desaturation." In order to assure a linear collector current ramp, the output transistor must remain in hard saturation during storage time and exhibit a rapid turn-off transition. A sluggish transition results in serious consequences. As the saturation voltage of the output transistor increases,

the voltage across the yoke drops. Roll off in the collector current ramp results in improper beam deflection and distortion of the image at the right edge of the screen. Design changes have been made in the structure of the SCANSWITCH series of devices which minimize the dynamic desaturation interval. Dynamic desaturation has been defined in terms of the time required for the  $V_{CE}$  to rise from 1.0 to 5.0 volts (Figures 9 and 10) and typical performance at optimized drive conditions has been specified. Optimization of device structure results in a linear collector current ramp, excellent turn-off switching performance, and significantly lower overall power dissipation.

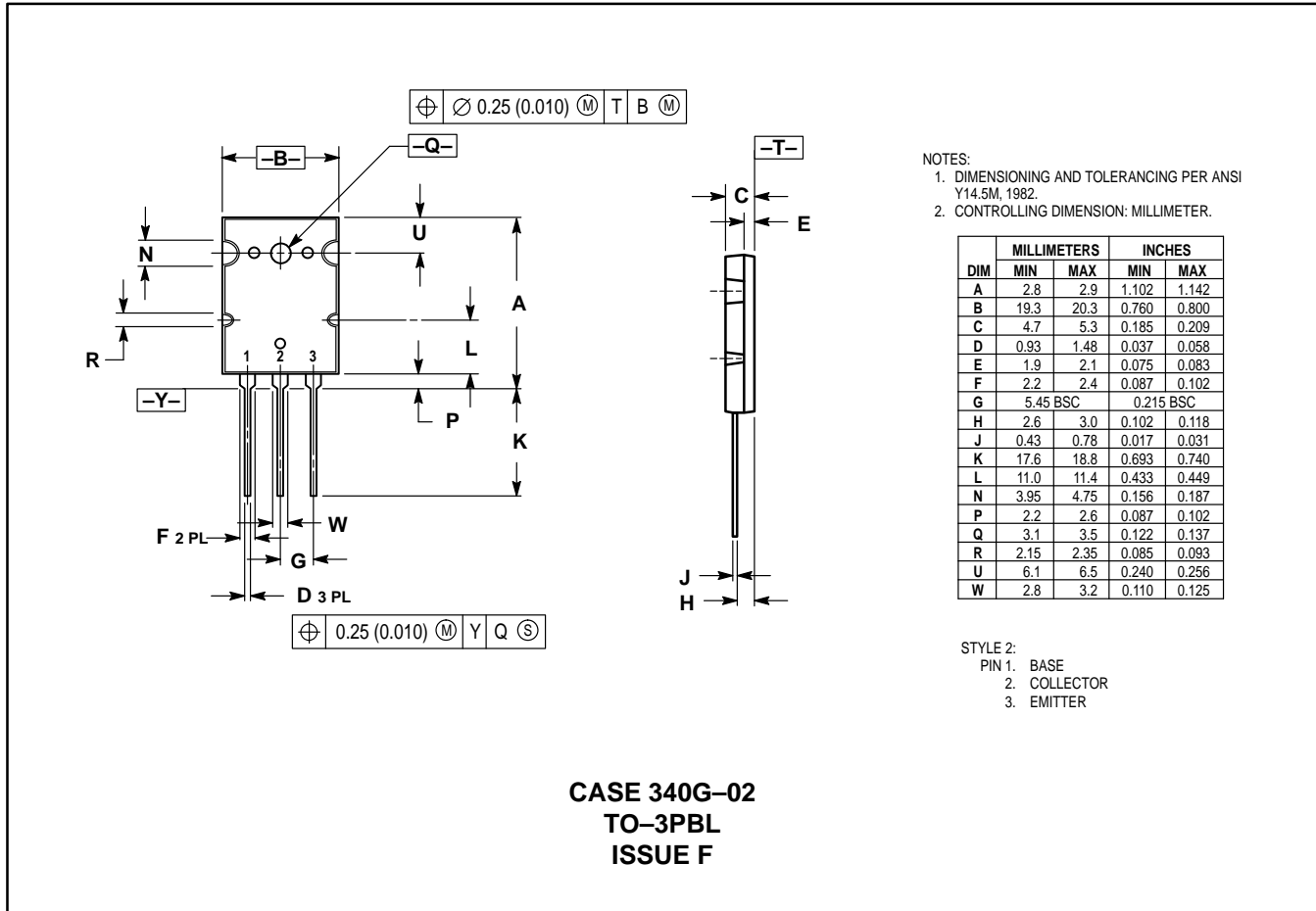


**Figure 11. Deflection Simulator Circuit Base Drive Waveform**



**Figure 12. Definition of Dynamic Desaturation Measurement**

PACKAGE DIMENSIONS



Motorola reserves the right to make changes without further notice to any products herein. Motorola makes no warranty, representation or guarantee regarding the suitability of its products for any particular purpose, nor does Motorola assume any liability arising out of the application or use of any product or circuit, and specifically disclaims any and all liability, including without limitation consequential or incidental damages. "Typical" parameters which may be provided in Motorola data sheets and/or specifications can and do vary in different applications and actual performance may vary over time. All operating parameters, including "Typicals" must be validated for each customer application by customer's technical experts. Motorola does not convey any license under its patent rights nor the rights of others. Motorola products are not designed, intended, or authorized for use as components in systems intended for surgical implant into the body, or other applications intended to support or sustain life, or for any other application in which the failure of the Motorola product could create a situation where personal injury or death may occur. Should Buyer purchase or use Motorola products for any such unintended or unauthorized application, Buyer shall indemnify and hold Motorola and its officers, employees, subsidiaries, affiliates, and distributors harmless against all claims, costs, damages, and expenses, and reasonable attorney fees arising out of, directly or indirectly, any claim of personal injury or death associated with such unintended or unauthorized use, even if such claim alleges that Motorola was negligent regarding the design or manufacture of the part. Motorola and are registered trademarks of Motorola, Inc. Motorola, Inc. is an Equal Opportunity/Affirmative Action Employer.