

## MM74C157 Quad 2-Input Multiplexers

### General Description

The MM74C157 multiplexers are monolithic complementary MOS (CMOS) integrated circuits constructed with N- and P-channel enhancement transistors. They consist of four 2-input multiplexers with common select and enable inputs. When the enable input is at logical "0" the four outputs assume the values as selected from the inputs. When the enable input is at logical "1", the outputs assume logical

"0". Select decoding is done internally resulting in a single select input only.

### Features

- Supply voltage range: 3V to 15V
- High noise immunity: 0.45  $V_{CC}$  (typ.)
- Low power: 50 nW (typ.)
- Tenth power TTL compatible: Drive 2 LPTTL loads

### Ordering Code:

Order Number	Package Number	Package Description
MM74C157N	N16E	16-Lead Plastic Dual-In-Line Package (PDIP), JEDEC MS-001, 0.300" Wide

### Connection Diagram

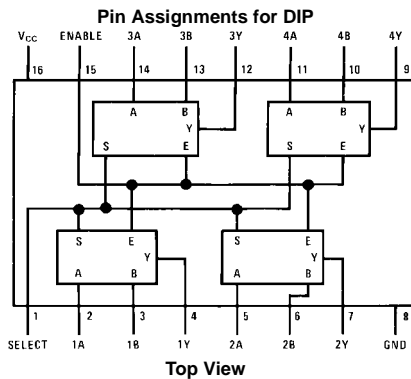

### Logic Diagram

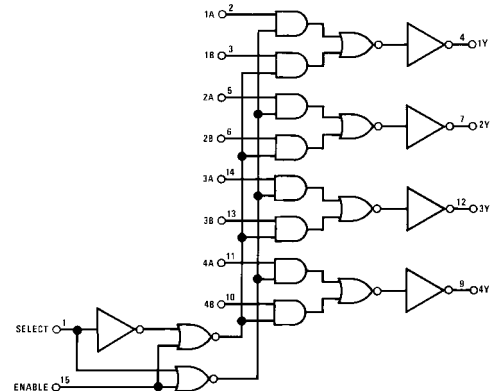

### Truth Table

Enable	Select	A	B	Output Y
1	X	X	X	0
0	0	0	X	0
0	0	1	X	1
0	1	X	0	0
0	1	X	1	1

<b>Absolute Maximum Ratings</b> (Note 1)		Operating $V_{CC}$ Range	3V to 15V
Voltage at Any Pin	-0.3V to $V_{CC} + 0.3V$	Lead Temperature	
Operating Temperature Range	-40°C to +85°C	(Soldering, 10 seconds)	260°C
Storage Temperature Range	-65°C to +150°C		
Maximum $V_{CC}$ Voltage	18V		
Power Dissipation ( $P_D$ )			
Dual-In-Line	700 mW		
Small Outline	500 mW		

**Note 1:** "Absolute Maximum Ratings" are those values beyond which the safety of the device cannot be guaranteed. Except for "Operating Temperature Range" they are not meant to imply that the devices should be operated at these limits. The table of "Electrical Characteristics" provides conditions for actual device operation.

## DC Electrical Characteristics

Min/Max limits apply across temperature range unless otherwise noted

Symbol	Parameter	Conditions	Min	Typ	Max	Units
<b>CMOS TO CMOS</b>						
$V_{IN(1)}$	Logical "1" Input Voltage	$V_{CC} = 5V$ $V_{CC} = 10V$	3.5 8.0			V V
$V_{IN(0)}$	Logical "0" Input Voltage	$V_{CC} = 5V$ $V_{CC} = 10V$			1.5 2.0	V V
$V_{OUT(1)}$	Logical "1" Output Voltage	$V_{CC} = 5V$ $V_{CC} = 10V$	4.5 9.0			V V
$V_{OUT(0)}$	Logical "0" Output Voltage	$V_{CC} = 5V$ $V_{CC} = 10V$			0.5 1.0	V V
$I_{IN(1)}$	Logical "1" Input Current	$V_{CC} = 15V$		0.005	1.0	$\mu A$
$I_{IN(0)}$	Logical "0" Input Current	$V_{CC} = 15V$	-1.0	-0.005		$\mu A$
$I_{CC}$	Supply Current	$V_{CC} = 15V$		0.05	60	$\mu A$
<b>CMOS TO TENTH POWER INTERFACE</b>						
$V_{IN(1)}$	Logical "1" Input Voltage	$V_{CC} = 4.75V$	$V_{CC} - 1.5$			V
$V_{IN(0)}$	Logical "0" Input Voltage	$V_{CC} = 4.75V$			0.8	V
$V_{OUT(1)}$	Logical "1" Output Voltage	$V_{CC} = 4.75V, I_O = -360 \mu A$	2.4			V
$V_{OUT(0)}$	Logical "0" Output Voltage	$V_{CC} = 4.75V, I_O = 360 \mu A$			0.4	V
<b>OUTPUT DRIVE (See Family Characteristics Data Sheet) (Short Circuit Current)</b>						
$I_{SOURCE}$	Output Source Current	$V_{CC} = 5V, V_{IN(0)} = 0V$ $T_A = 25^\circ C, V_{OUT} = 0V$	-1.75			mA
$I_{SOURCE}$	Output Source Current	$V_{CC} = 10V, V_{IN(0)} = 0V$ $T_A = 25^\circ C, V_{OUT} = 0V$	-8.0			mA
$I_{SINK}$	Output Sink Current	$V_{CC} = 5V, V_{IN(1)} = 5V$ $T_A = 25^\circ C, V_{OUT} = V_{CC}$	1.75			mA
$I_{SINK}$	Output Sink Current	$V_{CC} = 10V, V_{IN(1)} = 10V$ $T_A = 25^\circ C, V_{OUT} = V_{CC}$	8.0			mA

## AC Electrical Characteristics (Note 2)

$T_A = 25^\circ\text{C}$ ,  $C_L = 50\text{ pF}$ , unless otherwise specified

Symbol	Parameter	Conditions	Min	Typ	Max	Units
$t_{pd0}$ , $t_{pd1}$	Propagation Delay from Data to Output	$V_{CC} = 5.0\text{V}$ $V_{CC} = 10\text{V}$		150 70	250 110	ns
$t_{pd0}$ , $t_{pd1}$	Propagation Delay from Select to Output	$V_{CC} = 5\text{V}$ $V_{CC} = 10\text{V}$		180 80	300 130	ns
$t_{pd0}$ , $t_{pd1}$	Propagation Delay from Enable to Output	$V_{CC} = 5\text{V}$ $V_{CC} = 10\text{V}$		180 80	300 130	ns
$C_{IN}$	Input Capacitance	(Note 3)		5		pF
$C_{PD}$	Power Dissipation Capacitance	(Note 4)		20		pF

**Note 2:** AC Parameters are guaranteed by DC correlated testing.

**Note 3:** Capacitance is guaranteed by periodic testing.

**Note 4:**  $C_{PD}$  determines the no load AC power consumption of any CMOS device. For complete explanation, see Family Characteristics, Application Note AN-90.

## Typical Applications

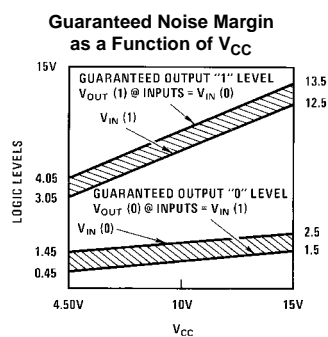
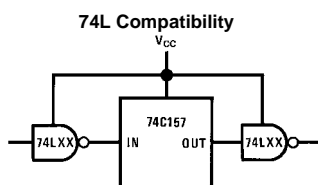

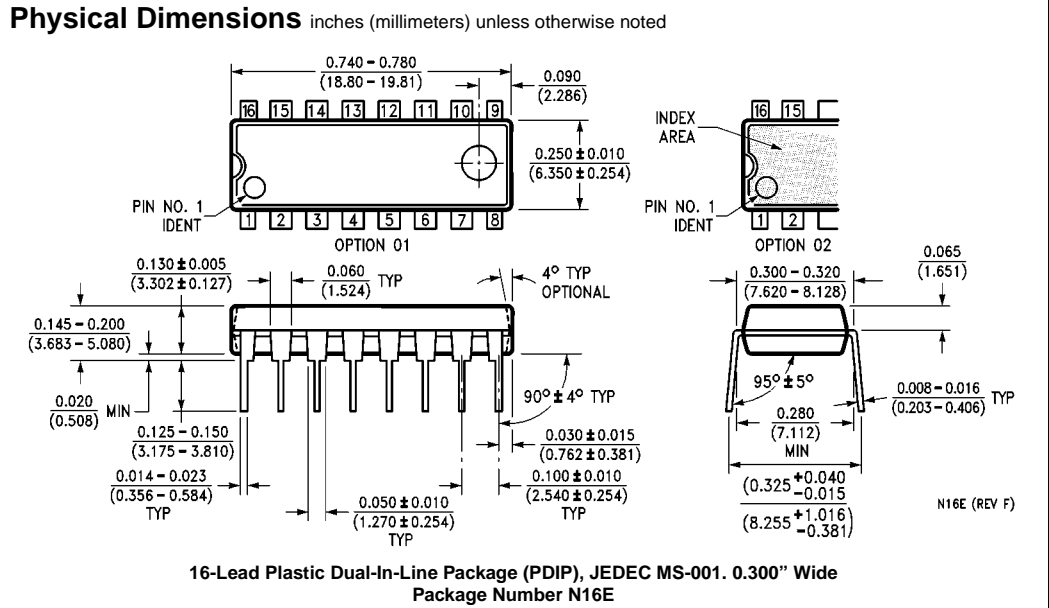

**LIFE SUPPORT POLICY**

FAIRCHILD'S PRODUCTS ARE NOT AUTHORIZED FOR USE AS CRITICAL COMPONENTS IN LIFE SUPPORT DEVICES OR SYSTEMS WITHOUT THE EXPRESS WRITTEN APPROVAL OF THE PRESIDENT OF FAIRCHILD SEMICONDUCTOR CORPORATION. As used herein:

1. Life support devices or systems are devices or systems which, (a) are intended for surgical implant into the body, or (b) support or sustain life, and (c) whose failure to perform when properly used in accordance with instructions for use provided in the labeling, can be reasonably expected to result in a significant injury to the user.
2. A critical component in any component of a life support device or system whose failure to perform can be reasonably expected to cause the failure of the life support device or system, or to affect its safety or effectiveness.

[www.fairchildsemi.com](http://www.fairchildsemi.com)