

## MM74C89 64-Bit 3-STATE Random Access Read/Write Memory

### General Description

The MM74C89 is a 16-word by 4-bit random access read/write memory. Inputs to the memory consist of four address lines, four data input lines, a write enable line and a memory enable line. The four binary address inputs are decoded internally to select each of the 16 possible word locations. An internal address register latches the address information on the positive to negative transition of the memory enable input. The four 3-STATE data output lines working in conjunction with the memory enable input provide for easy memory expansion.

**Address Operation:** Address inputs must be stable  $t_{SA}$  prior to the positive to negative transition of memory enable. It is thus not necessary to hold address information stable for more than  $t_{HA}$  after the memory is enabled (positive to negative transition of memory enable).

**Write Operation:** Information present at the data inputs is written into the memory at the selected address by bringing write enable and memory enable LOW.

**Read Operation:** The complement of the information which was written into the memory is non-destructively read out at the four outputs. This is accomplished by selecting the desired address and bringing memory enable LOW and write enable HIGH.

When the device is writing or disabled the output assumes a 3-STATE (Hi-z) condition.

### Features

- Wide supply voltage range: 3.0V to 15V
- Guaranteed noise margin: 1.0V
- High noise immunity:  $0.45 V_{CC}$  (typ.)
- Low power TTL compatibility:  
fan out of 2 driving 74L
- Low power consumption: 100 nW/package (typ.)
- Fast access time: 130 ns (typ.) at  $V_{CC} = 10V$
- 3-STATE output

**Note:** The timing is different than the DM7489 in that a positive to negative transition of the memory enable must occur for the memory to be selected.

### Ordering Code:

Order Number	Package Number	Package Description
MM74C89N	N16E	16-Lead Plastic Dual-In-Line Package (PDIP), JEDEC MS-001, 0.300" Wide

### Connection Diagram

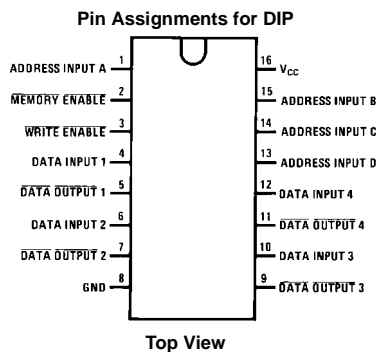

### Truth Table

ME	WE	Operation	Condition of Outputs
L	L	Write	3-STATE
L	H	Read	Complement of Selected Word
H	L	Inhibit, Storage	3-STATE
H	H	Inhibit, Storage	3-STATE

Logic Diagram

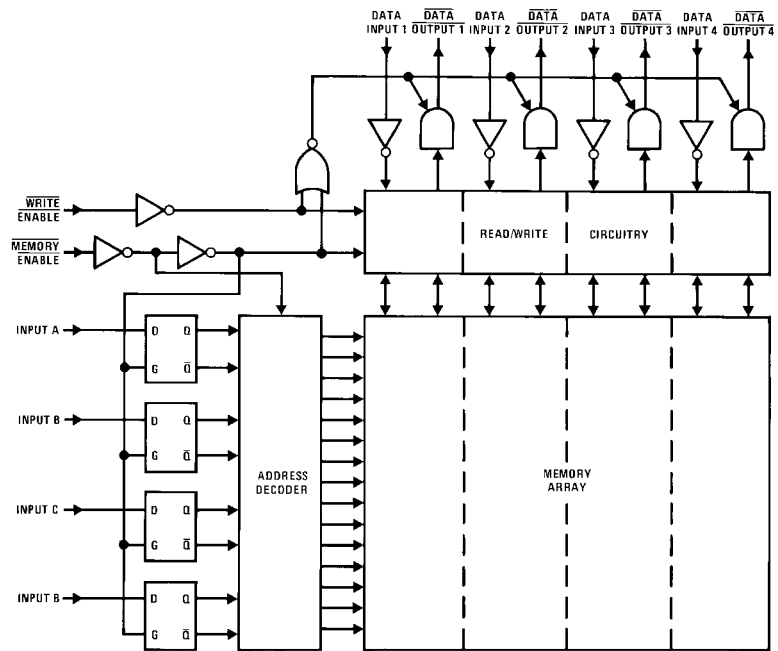

<b>Absolute Maximum Ratings</b> (Note 1)		Absolute Maximum $V_{CC}$	18V
Voltage at any Pin	-0.3V to $V_{CC} + 0.3V$	Lead Temperature ( $T_L$ )	260°C
Operating Temperature Range	-40°C to +85°C	(Soldering, 10 seconds)	
Storage Temperature Range ( $T_S$ )	-65°C to +150°C		
Power Dissipation ( $P_D$ )			
Dual-In-Line	700 mW		
Small Outline	500 mW		
Operating $V_{CC}$ Range	3.0V to 15V		

**Note 1:** "Absolute Maximum Ratings" are those values beyond which the safety of the device cannot be guaranteed. Except for "Operating Range" they are not meant to imply that the devices should be operated at these limits. The table of "Electrical Characteristics" provides conditions for actual device operation.

## DC Electrical Characteristics

Min/Max limits apply across temperature range, unless otherwise noted

Symbol	Parameter	Conditions	Min	Typ	Max	Units
<b>CMOS TO CMOS</b>						
$V_{IN(1)}$	Logical "1" Input Voltage	$V_{CC} = 5.0V$ $V_{CC} = 10V$	3.5 8.0			V
$V_{IN(0)}$	Logical "0" Input Voltage	$V_{CC} = 5.0V$ $V_{CC} = 10V$			1.5 2.0	V
$V_{OUT(1)}$	Logical "1" Output Voltage	$V_{CC} = 5.0V, I_O = -10 \mu A$ $V_{CC} = 10V, I_O = -10 \mu A$	4.5 9.0			V
$V_{OUT(0)}$	Logical "0" Output Voltage	$V_{CC} = 5.0V, I_O = +10 \mu A$ $V_{CC} = 10V, I_O = +10 \mu A$			0.5 1.0	V
$I_{IN(1)}$	Logical "1" Input Current	$V_{CC} = 15V, V_{IN} = 15V$		-0.005	1.0	$\mu A$
$I_{IN(0)}$	Logical "0" Input Current	$V_{CC} = 15V, V_{IN} = 0V$	-1.0	-0.005		$\mu A$
$I_{OZ}$	Output Current in High Impedance State	$V_{CC} = 15V, V_O = 15V$ $V_{CC} = 15V, V_O = 0V$	-1.0	0.005	1.0	$\mu A$
$I_{CC}$	Supply Current	$V_{CC} = 15V$		0.05	300	$\mu A$
<b>CMOS/LPTTL INTERFACE</b>						
$V_{IN(1)}$	Logical "1" Input Voltage	$V_{CC} = 4.75V$	$V_{CC} - 1.5$			V
$V_{IN(0)}$	Logical "0" Input Voltage	$V_{CC} = 4.75V$			0.8	V
$V_{OUT(1)}$	Logical "1" Output Voltage	$V_{CC} = 4.75V, I_O = -360 \mu A$	2.4			V
$V_{OUT(0)}$	Logical "0" Output Voltage	$V_{CC} = 4.75V, I_O = +360 \mu A$			0.4	V
<b>OUTPUT DRIVE (See 54C74C Family Characteristics Data Sheet) (Short Circuit Current)</b>						
$I_{SOURCE}$	Output Source Current (P-Channel)	$V_{CC} = 5.0V, V_{OUT} = 0V$ $T_A = 25^\circ C$	-1.75	-3.3		mA
$I_{SOURCE}$	Output Source Current (P-Channel)	$V_{CC} = 10V, V_{OUT} = 0V$ $T_A = 25^\circ C$	-8.0	-15		mA
$I_{SINK}$	Output Sink Current (N-Channel)	$V_{CC} = 5.0V, V_{OUT} = V_{CC}$ $T_A = 25^\circ C$	1.75	3.6		mA
$I_{SINK}$	Output Sink Current (N-Channel)	$V_{CC} = 10V, V_{OUT} = V_{CC}$ $T_A = 25^\circ C$	8.0	16		mA

AC Electrical Characteristics (Note 2)						
T <sub>A</sub> = 25°C, C <sub>L</sub> = 50 pF, unless otherwise noted						
Symbol	Parameter	Conditions	Min	Typ	Max	Units
t <sub>pd</sub>	Propagation Delay from Memory Enable	V <sub>CC</sub> = 5V		270	500	ns
		V <sub>CC</sub> = 10V		100	220	ns
t <sub>ACC</sub>	Access Time from Address Input	V <sub>CC</sub> = 5V		350	650	ns
		V <sub>CC</sub> = 10V		130	280	ns
t <sub>SA</sub>	Address Setup Time	V <sub>CC</sub> = 5V	150			ns
		V <sub>CC</sub> = 10V	60			ns
t <sub>HA</sub>	Address Hold Time	V <sub>CC</sub> = 5V	60			ns
		V <sub>CC</sub> = 10V	40			ns
t <sub>ME</sub>	Memory Enable Pulse Width	V <sub>CC</sub> = 5V	400	250		ns
		V <sub>CC</sub> = 10V	150	90		ns
t <sub>SR</sub>	Write Enable Setup Time for a Read	V <sub>CC</sub> = 5V	0			ns
		V <sub>CC</sub> = 10V	0			ns
t <sub>WS</sub>	Write Enable Setup Time for a Write	V <sub>CC</sub> = 5V			t <sub>ME</sub>	ns
		V <sub>CC</sub> = 10V			t <sub>ME</sub>	ns
t <sub>WE</sub>	Write Enable Pulse Width	V <sub>CC</sub> = 5V, t <sub>WS</sub> = 0	300	160		ns
		V <sub>CC</sub> = 10V, t <sub>WS</sub> = 0	100	60		ns
t <sub>HD</sub>	Data Input Hold Time	V <sub>CC</sub> = 5V	50			ns
		V <sub>CC</sub> = 10V	25			ns
t <sub>SD</sub>	Data Input Setup	V <sub>CC</sub> = 5V	50			ns
		V <sub>CC</sub> = 10V	25			ns
t <sub>1H</sub> , t <sub>0H</sub>	Propagation Delay from a Logical "1" or Logical "0" to the High Impedance State from Memory Enable	V <sub>CC</sub> = 5V, C <sub>L</sub> = 5 pF, R <sub>L</sub> = 10k		180	300	ns
		V <sub>CC</sub> = 10V, C <sub>L</sub> = 5 pF, R <sub>L</sub> = 10k		-85	120	ns
t <sub>1H</sub> , t <sub>0H</sub>	Propagation Delay from a Logical "1" or Logical "0" to the High Impedance State from Write Enable	V <sub>CC</sub> = 50V, C <sub>L</sub> = 5 pF, R <sub>L</sub> = 10k		180	300	ns
		V <sub>CC</sub> = 10V, C <sub>L</sub> = 5 pF, R <sub>L</sub> = 10k		85	120	ns
C <sub>IN</sub>	Input Capacity	Any Input (Note 3)		5		pF
C <sub>OUT</sub>	Output Capacity	Any Output (Note 3)		6.5		pF
C <sub>PD</sub>	Power Dissipation Capacity	(Note 4)		230		pF

**Note 2:** AC Parameters are guaranteed by DC correlated testing.

**Note 3:** Capacitance is guaranteed by periodic testing.

**Note 4:** C<sub>PD</sub> determines the no load AC power consumption of any CMOS device. For complete explanation see Family Characteristics application note, AN-90.

AC Test Circuits

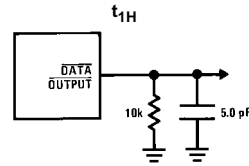
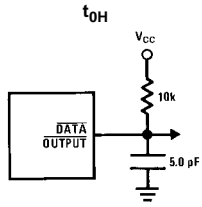

Switching Time Waveforms

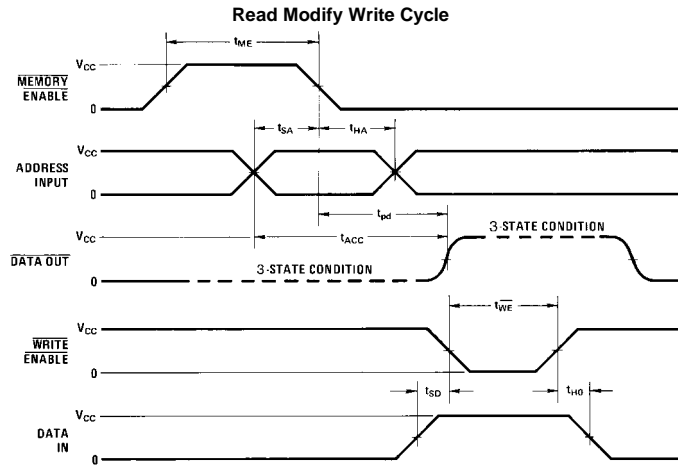
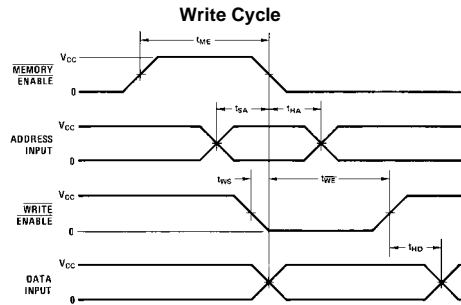
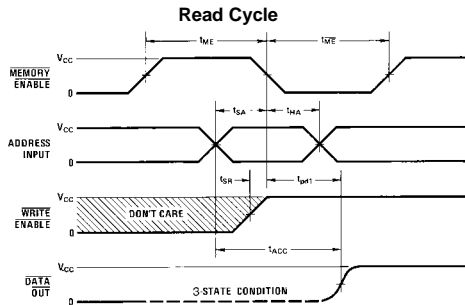
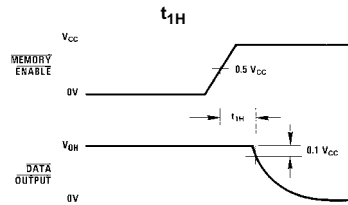
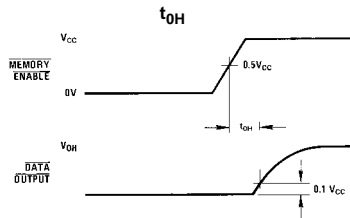

$t_f = 10 \text{ ns}$   
 $t_r = 60 \text{ ns}$

**Physical Dimensions** inches (millimeters) unless otherwise noted

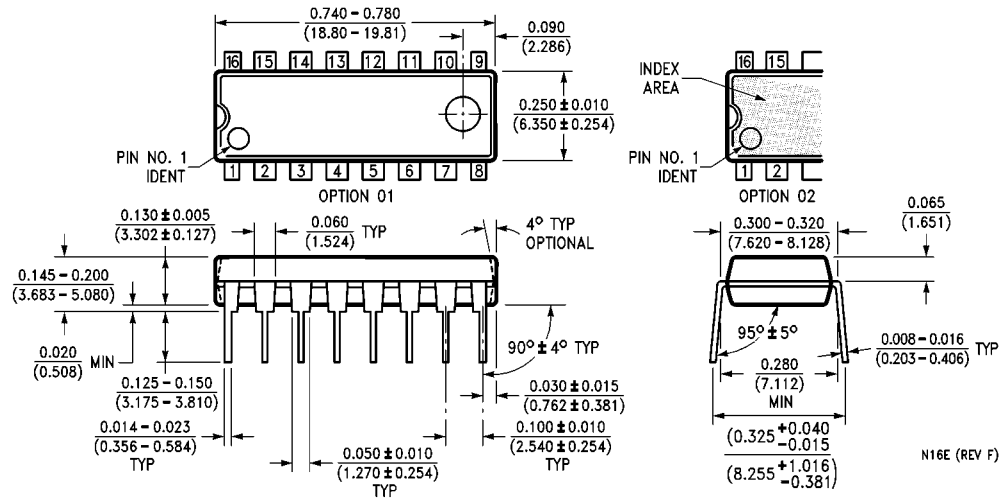

16-Lead Plastic Dual-In-Line Package (PDIP), JEDEC MS-001, 0.300" Wide  
Package Number N16E

N16E (REV F)

**LIFE SUPPORT POLICY**

FAIRCHILD'S PRODUCTS ARE NOT AUTHORIZED FOR USE AS CRITICAL COMPONENTS IN LIFE SUPPORT DEVICES OR SYSTEMS WITHOUT THE EXPRESS WRITTEN APPROVAL OF THE PRESIDENT OF FAIRCHILD SEMICONDUCTOR CORPORATION. As used herein:

1. Life support devices or systems are devices or systems which, (a) are intended for surgical implant into the body, or (b) support or sustain life, and (c) whose failure to perform when properly used in accordance with instructions for use provided in the labeling, can be reasonably expected to result in a significant injury to the user.
2. A critical component in any component of a life support device or system whose failure to perform can be reasonably expected to cause the failure of the life support device or system, or to affect its safety or effectiveness.

[www.fairchildsemi.com](http://www.fairchildsemi.com)