

DRAM

1 MEG x 4 DRAM

STANDARD OR SELF REFRESH

DRAM

FEATURES

- 1,024-cycle refresh distributed across 16ms (MT4C4001J) or 128ms (MT4C4001J S)
- Industry-standard pinout, timing, functions and packages
- High-performance CMOS silicon-gate process
- Single +5V ±10% power supply
- All inputs, outputs and clocks are TTL-compatible
- Refresh modes: RAS ONLY, CAS-BEFORE-RAS (CBR), HIDDEN; optional Extended and SELF REFRESH modes (MT4C4001J S only)
- FAST PAGE MODE access cycle
- Low power, 0.8mW standby; 225mW active, typical (MT4C4001J S)

OPTIONS

- Timing

60ns access	-6
70ns access	-7
80ns access	-8
- Packages

Plastic SOJ (300 mil)	DJ
Plastic TSOP (300 mil)	TG
- Version

1,024-cycle refresh in 16ms	None
1,024-cycle refresh in 128ms	S
- Part Number Example: MT4C4001JDJ-6 S

MARKING

GENERAL DESCRIPTION

The MT4C4001J(S) is a randomly accessed solid-state memory containing 4,194,304 bits organized in a x4 configuration. During READ or WRITE cycles, each bit is uniquely addressed through the 20 address bits, which are entered 10 bits (A0-A9) at a time. RAS is used to latch the first 10 bits and CAS the latter 10 bits. READ and WRITE cycles are selected with the WE input. A logic HIGH on WE dictates READ mode while a logic LOW on WE dictates WRITE mode. During a WRITE cycle, data-in (D) is latched by the falling edge of WE or CAS, whichever occurs last. If WE goes LOW prior to CAS going LOW, the output pin(s) remain open (High-Z) until the next CAS cycle. If WE goes LOW after data reaches the output pins, the outputs (Qs) are activated and retain the selected cell data as long as CAS remains LOW (regardless of WE or RAS). This late WE pulse

PIN ASSIGNMENT (Top View)

20/26-Pin SOJ (DC-1)

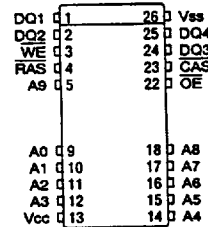

20/26-Pin TSOP (DD-1)

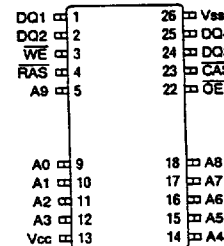

results in a READ WRITE cycle. The four data inputs and four data outputs are routed through four pins using common I/O and pin direction is controlled by WE and OE.

FAST PAGE MODE operations allow faster data operations (READ, WRITE or READ-MODIFY-WRITE) within a row-address-defined (A0-A9) page boundary. The FAST PAGE MODE cycle is always initiated with a row-address strobed-in by RAS followed by a column-address strobed-in by CAS. CAS may be toggled-in by holding RAS LOW and strobing-in different column-addresses, thus executing faster memory cycles. Returning RAS HIGH terminates the FAST PAGE MODE operation.

Returning RAS and CAS HIGH terminates a memory cycle and decreases chip current to a reduced standby level. Also, the chip is preconditioned for the next cycle during the

DRAM

$\overline{\text{RAS}}$ HIGH time. Memory cell data is retained in its correct state by maintaining power and executing any $\overline{\text{RAS}}$ cycle (READ, WRITE) or $\overline{\text{RAS}}$ REFRESH cycle ($\overline{\text{RAS}}$ ONLY, CBR, or HIDDEN) so that all 1,024 combinations of $\overline{\text{RAS}}$ addresses (A0-A9) are executed at least every 16ms for the MT4C4001J and every 128ms for the MT4C4001J S, regardless of sequence. The CBR REFRESH cycle will invoke the internal refresh counter for automatic $\overline{\text{RAS}}$ addressing.

REFRESH

An optional SELF REFRESH mode is also available. The "S" option allows the user the choice of a fully static low-power data retention mode, or a dynamic refresh mode at the extended refresh period.

The optional SELF REFRESH feature is initiated by performing a CBR REFRESH cycle and holding $\overline{\text{RAS}}$ LOW

for the specified t_{RASS} . Additionally, the "S" option allows for an extended refresh rate of 125 μ s per row if using distributed CBR REFRESH. This refresh rate can be applied during normal operation or during a standby mode.

The SELF REFRESH mode is terminated by driving $\overline{\text{RAS}}$ HIGH for a minimum time of t_{RPS} ($\sim t_{\text{RC}}$). This delay allows for the completion of any internal refresh cycles that may be in process at the time of the $\overline{\text{RAS}}$ LOW-to-HIGH transition. If the DRAM controller uses a distributed CBR refresh sequence, a burst refresh is not required upon exiting SELF REFRESH mode. However, if the DRAM controller utilizes $\overline{\text{RAS}}$ ONLY or BURST REFRESH sequence, all rows must be refreshed within 300 μ s prior to the resumption of normal operation.

FUNCTIONAL BLOCK DIAGRAM
FAST PAGE MODE

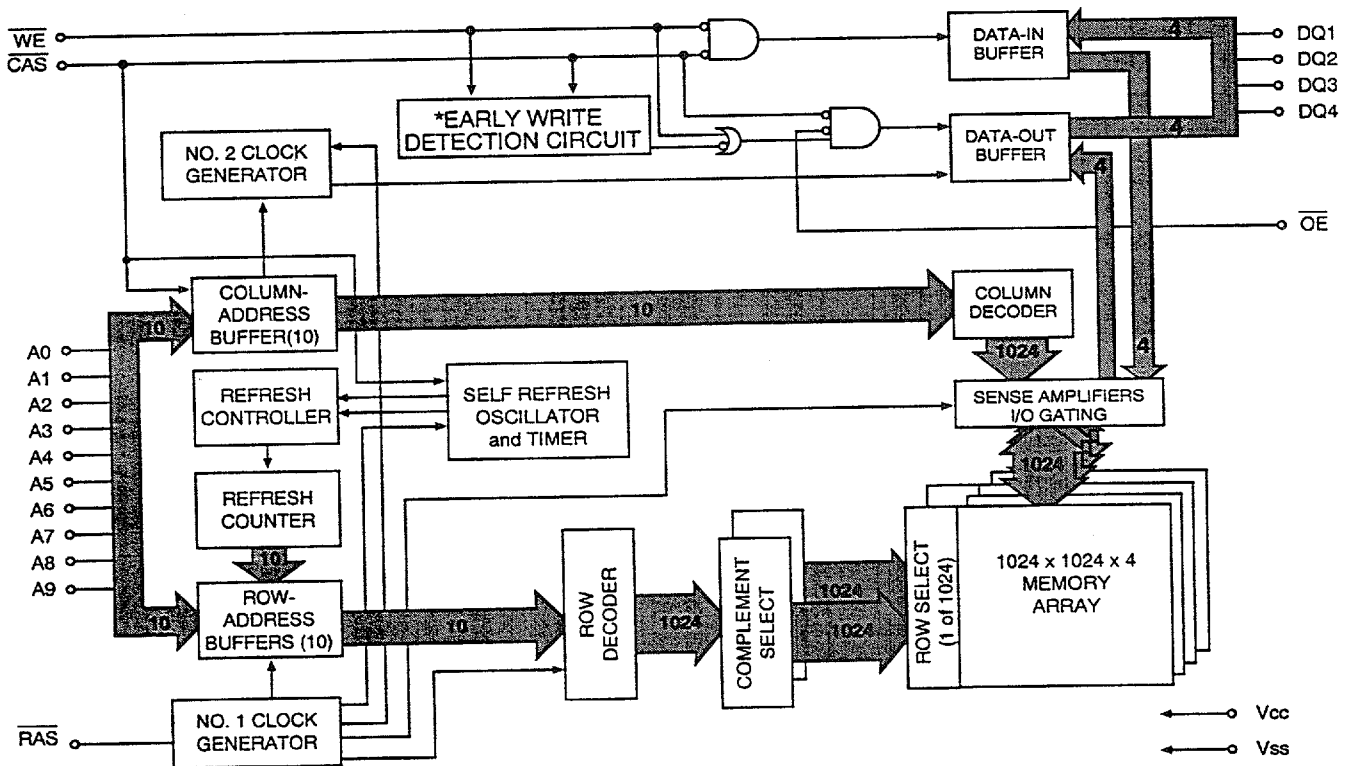

***NOTE:** 1. If $\overline{\text{WE}}$ goes LOW prior to $\overline{\text{CAS}}$ going LOW, EW detection circuit output is a HIGH (EARLY WRITE).
2. If $\overline{\text{CAS}}$ goes LOW prior to $\overline{\text{WE}}$ going LOW, EW detection circuit output is a LOW (LATE WRITE).

TRUTH TABLE

FUNCTION		RAS	CAS	WE	OE	ADDRESSES		DATA-IN/OUT
						'R	'C	DQ1-DQ4
Standby		H	H→X	X	X	X	X	High-Z
READ		L	L	H	L	ROW	COL	Data-Out
EARLY WRITE		L	L	L	X	ROW	COL	Data-In
READ WRITE		L	L	H→L	L→H	ROW	COL	Data-Out, Data-In
FAST-PAGE-MODE READ	1st Cycle	L	H→L	H	L	ROW	COL	Data-Out
	2nd Cycle	L	H→L	H	L	n/a	COL	Data-Out
FAST-PAGE-MODE EARLY-WRITE	1st Cycle	L	H→L	L	X	ROW	COL	Data-In
	2nd Cycle	L	H→L	L	X	n/a	COL	Data-In
FAST-PAGE-MODE READ-WRITE	1st Cycle	L	H→L	H→L	L→H	ROW	COL	Data-Out, Data-In
	2nd Cycle	L	H→L	H→L	L→H	n/a	COL	Data-Out, Data-In
RAS ONLY REFRESH		L	H	X	X	ROW	n/a	High-Z
HIDDEN REFRESH	READ	L→H→L	L	H	L	ROW	COL	Data-Out
	WRITE	L→H→L	L	L	X	ROW	COL	Data-In
CBR REFRESH		H→L	L	H	X	X	X	High-Z
SELF REFRESH (MT4C4001J S only)		H→L	L	H	X	X	X	High-Z

DRAM

ABSOLUTE MAXIMUM RATINGS*

Voltage on Any Pin Relative to V_{SS} -1V to +7V
 Operating Temperature, T_A (ambient) 0°C to +70°C
 Storage Temperature (plastic) -55°C to +150°C
 Power Dissipation 1W
 Short Circuit Output Current 50mA

*Stresses greater than those listed under "Absolute Maximum Ratings" may cause permanent damage to the device. This is a stress rating only and functional operation of the device at these or any other conditions above those indicated in the operational sections of this specification is not implied. Exposure to absolute maximum rating conditions for extended periods may affect reliability.

ELECTRICAL CHARACTERISTICS AND RECOMMENDED DC OPERATING CONDITIONS

(Notes: 1, 6, 7) (V_{CC} = +5V ±10%)

PARAMETER/CONDITION	SYMBOL	MIN	MAX	UNITS	NOTES
Supply Voltage	V _{CC}	4.5	5.5	V	
Input High (Logic 1) Voltage, all inputs	V _{IH}	2.4	V _{CC} +1	V	
Input Low (Logic 0) Voltage, all inputs	V _{IL}	-1.0	0.8	V	
INPUT LEAKAGE CURRENT Any input 0V ≤ V _{IN} ≤ 6.5V (All other pins not under test = 0V)	I _I	-2	2	μA	
OUTPUT LEAKAGE CURRENT (Q is disabled; 0V ≤ V _{OUT} ≤ 5.5V)	I _{OZ}	-10	10	μA	
OUTPUT LEVELS Output High Voltage (I _{OUT} = -5mA)	V _{OH}	2.4		V	
Output Low Voltage (I _{OUT} = 4.2mA)	V _{OL}		0.4	V	

4

ELECTRICAL CHARACTERISTICS AND RECOMMENDED DC OPERATING CONDITIONS

(Notes: 1, 6, 7) ($V_{CC} = +5V \pm 10\%$)

PARAMETER/CONDITION	VERSION	SYMBOL	MAX			UNITS	NOTES
			-6	-7	-8		
STANDBY CURRENT: (TTL) ($\overline{RAS} = \overline{CAS} = V_{IH}$)		Icc1	2	2	2	mA	
STANDBY CURRENT: (CMOS) ($\overline{RAS} = \overline{CAS} = V_{CC} - 0.2V$)	MT4C4001J	Icc2	1	1	1	mA	
	MT4C4001J S	Icc2	200	200	200	μA	
OPERATING CURRENT: Random READ/WRITE Average power supply current ($\overline{RAS}, \overline{CAS}$, Single Address Cycling: $t'RC = t'RC$ [MIN])		Icc3	110	100	90	mA	3, 4, 30
OPERATING CURRENT: FAST PAGE MODE Average power supply current ($\overline{RAS} = V_{IL}, \overline{CAS}$, Address Cycling: $t'PC = t'PC$ [MIN])		Icc4	80	70	60	mA	3, 4, 30
REFRESH CURRENT: \overline{RAS} ONLY Average power supply current (\overline{RAS} Cycling, $\overline{CAS} = V_{IH}$: $t'RC = t'RC$ [MIN])		Icc5	110	100	90	mA	3, 30
REFRESH CURRENT: CBR Average power supply current ($\overline{RAS}, \overline{CAS}$, Address Cycling: $t'RC = t'RC$ [MIN])		Icc6	110	100	90	mA	3, 5
REFRESH CURRENT: Extended Average power supply current during Extended Refresh: $\overline{CAS} = 0.2V$ or CBR cycling; $\overline{RAS} = t'RAS$ (MIN); $\overline{WE}, A0-A9$ and $D_{IN} = V_{CC} - 0.2V$ or $0.2V$; (D_{IN} may be left open); $t'RC = 125\mu s$ (1,024 rows at $125\mu s = 128ms$)	MT4C4001J S	Icc7	300	300	300	μA	3, 5, 28
SELF REFRESH CURRENT: Average power supply current during SELF REFRESH: CBR cycle with $t'RAS \geq t'RASS$ (MIN) and \overline{CAS} held LOW; $\overline{WE} = V_{CC} - .2$; $A0-A9$ and $D_{IN} = V_{CC} - .2V$ or $.2V$ (D_{IN} may be left open)	MT4C4001J S	Icc8	300	300	300	μA	5, 31

DRAM

CAPACITANCE

PARAMETER	SYMBOL	MIN	MAX	UNITS	NOTES
Input Capacitance: A0-A9	C11		5	pF	2
Input Capacitance: $\overline{RAS}, \overline{CAS}, \overline{WE}, \overline{OE}$	C12		7	pF	2
Input/Output Capacitance: DQ	C10		7	pF	2

ELECTRICAL CHARACTERISTICS AND RECOMMENDED AC OPERATING CONDITIONS

(Notes: 6, 7, 8, 9, 10, 11, 12, 13, 23) (V_{CC} = +5V ±10%)

DRAM

AC CHARACTERISTICS		-6		-7		-8			
PARAMETER	SYM	MIN	MAX	MIN	MAX	MIN	MAX	UNITS	NOTES
Random READ or WRITE cycle time	^t RC	110		130		150		ns	
READ WRITE cycle time	^t RWC	150		180		200		ns	
FAST-PAGE-MODE READ or WRITE cycle time	^t PC	35		40		45		ns	
FAST-PAGE-MODE READ-WRITE cycle time	^t PRWC	85		100		105		ns	
Access time from $\overline{\text{RAS}}$	^t RAC		60		70		80	ns	14
Access time from $\overline{\text{CAS}}$	^t CAC		15		20		20	ns	15
Output Enable	^t OE		15		20		20	ns	23
Access time from column-address	^t AA		30		35		40	ns	
Access time from $\overline{\text{CAS}}$ precharge	^t CPA		35		40		45	ns	
$\overline{\text{RAS}}$ pulse width	^t RAS	60	100,000	70	100,000	80	100,000	ns	
$\overline{\text{RAS}}$ pulse width (FAST PAGE MODE)	^t RASP	60	100,000	70	100,000	80	100,000	ns	
$\overline{\text{RAS}}$ hold time	^t RSH	15		20		20		ns	
$\overline{\text{RAS}}$ precharge time	^t RP	40		50		60		ns	
$\overline{\text{CAS}}$ pulse width	^t CAS	15	100,000	20	100,000	20	100,000	ns	
$\overline{\text{CAS}}$ hold time	^t CSH	60		70		80		ns	
$\overline{\text{CAS}}$ precharge time (CBR REFRESH)	^t CPN	10		10		10		ns	16
$\overline{\text{CAS}}$ precharge time (FAST PAGE MODE)	^t CP	10		10		10		ns	
$\overline{\text{RAS}}$ to $\overline{\text{CAS}}$ delay time	^t RCD	20	45	20	50	20	60	ns	17
$\overline{\text{CAS}}$ to $\overline{\text{RAS}}$ precharge time	^t CRP	10		10		10		ns	
Row-address setup time	^t ASR	0		0		0		ns	
Row-address hold time	^t RAH	10		10		10		ns	
$\overline{\text{RAS}}$ to column-address delay time	^t RAD	15	30	15	35	15	40	ns	18
Column-address setup time	^t ASC	0		0		0		ns	
Column-address hold time	^t CAH	10		15		15		ns	
Column-address hold time (referenced to $\overline{\text{RAS}}$)	^t AR	45		50		55		ns	
Column-address to $\overline{\text{RAS}}$ lead time	^t RAL	30		35		40		ns	
Read command setup time	^t RCS	0		0		0		ns	
Read command hold time (referenced to $\overline{\text{CAS}}$)	^t RCH	0		0		0		ns	19
Read command hold time (referenced to $\overline{\text{RAS}}$)	^t RRH	0		0		0		ns	19
$\overline{\text{CAS}}$ to output in Low-Z	^t CLZ	0		0		0		ns	
Output buffer turn-off delay	^t OFF	3	15	3	20	3	20	ns	20, 29

ELECTRICAL CHARACTERISTICS AND RECOMMENDED AC OPERATING CONDITIONS

(Notes: 6, 7, 8, 9, 10, 11, 12, 13, 23) ($V_{CC} = +5V \pm 10\%$)

AC CHARACTERISTICS		-6		-7		-8			
PARAMETER	SYM	MIN	MAX	MIN	MAX	MIN	MAX	UNITS	NOTES
\overline{WE} command setup time	t_{WCS}	0		0		0		ns	21, 27
Write command hold time	t_{WCH}	10		15		15		ns	
Write command hold time (referenced to \overline{RAS})	t_{WCR}	45		55		60		ns	
Write command pulse width	t_{WP}	10		15		15		ns	
Write command to \overline{RAS} lead time	t_{RWL}	15		20		20		ns	
Write command to \overline{CAS} lead time	t_{CWL}	15		20		20		ns	
Data-in setup time	t_{DS}	0		0		0		ns	22
Data-in hold time	t_{DH}	10		15		15		ns	22
Data-in hold time (referenced to \overline{RAS})	t_{DHR}	45		55		60		ns	
\overline{RAS} to \overline{WE} delay time	t_{RWD}	90		100		110		ns	21
Column-address to \overline{WE} delay time	t_{AWD}	55		65		70		ns	21
\overline{CAS} to \overline{WE} delay time	t_{CWD}	40		50		50		ns	21
Transition time (rise or fall)	t_T	3	50	3	50	3	50	ns	9, 10
Refresh period (1,024 cycles) MT4C4001J / MT4C4001J S	t_{REF}		16 / 128		16 / 128		16 / 128	ms	
\overline{RAS} to \overline{CAS} precharge time	t_{RPC}	0		0		0		ns	
\overline{CAS} setup time (CBR REFRESH)	t_{CSR}	10		10		10		ns	5
\overline{CAS} hold time (CBR REFRESH)	t_{CHR}	10		10		10		ns	5
\overline{WE} hold time (CBR REFRESH)	t_{WRH}	10		10		10		ns	25
\overline{WE} setup time (CBR REFRESH)	t_{WRP}	10		10		10		ns	25
\overline{WE} hold time (WCBR test cycle)	t_{WTH}	10		10		10		ns	25
\overline{WE} setup time (WCBR test cycle)	t_{WTS}	10		10		10		ns	25
\overline{OE} setup prior to \overline{RAS} during HIDDEN REFRESH cycle	t_{ORD}	0		0		0		ns	
Output disable	t_{OD}		15		20		20	ns	27
\overline{OE} hold time from \overline{WE} during READ-MODIFY-WRITE cycle	t_{OEH}	15		20		20		ns	26
\overline{RAS} pulse width during SELF REFRESH cycle	t_{RASS}	100		100		100		μ s	31
\overline{RAS} precharge time during SELF REFRESH cycle	t_{RPS}	110		130		150		ns	31
\overline{RAS} LOW to "don't care" during SELF REFRESH cycle	t_{CHD}	10		10		10		ns	31

NOTES

1. All voltages referenced to V_{SS}.
2. This parameter is sampled. V_{CC} = 5V ±10%; f = 1 MHz.
3. I_{CC} is dependent on cycle rates.
4. I_{CC} is dependent on output loading and cycle rates. Specified values are obtained with minimum cycle time and the outputs open.
5. Enables on-chip refresh and address counters.
6. The minimum specifications are used only to indicate cycle time at which proper operation over the full temperature range is assured.
7. An initial pause of 100µs is required after power-up followed by eight RAS refresh cycles (RAS ONLY or CBR with WE HIGH) before proper device operation is assured. The eight RAS cycle wake-ups should be repeated any time the tREF refresh requirement is exceeded.
8. AC characteristics assume tT = 5ns.
9. V_{IH} (MIN) and V_{IL} (MAX) are reference levels for measuring timing of input signals. Transition times are measured between V_{IH} and V_{IL} (or between V_{IL} and V_{IH}).
10. In addition to meeting the transition rate specification, all input signals must transit between V_{IH} and V_{IL} (or between V_{IL} and V_{IH}) in a monotonic manner.
11. If CAS = V_{IH}, data output is High-Z.
12. If CAS = V_{IL}, data output may contain data from the last valid READ cycle.
13. Measured with a load equivalent to two TTL gates and 100pF.
14. Assumes that tRCD < tRCD (MAX). If tRCD is greater than the maximum recommended value shown in this table, tRAC will increase by the amount that tRCD exceeds the value shown.
15. Assumes that tRCD ≥ tRCD (MAX).
16. If CAS is LOW at the falling edge of RAS, Q will be maintained from the previous cycle. To initiate a new cycle and clear the data-out buffer, CAS must be pulsed HIGH for tCPN.
17. Operation within the tRCD (MAX) limit ensures that tRAC (MAX) can be met. tRCD (MAX) is specified as a reference point only; if tRCD is greater than the specified tRCD (MAX) limit, then access time is controlled exclusively by tCAC.
18. Operation within the tRAD (MAX) limit ensures that tRAC (MIN) and tCAC (MIN) can be met. tRAD (MAX) is specified as a reference point only; if tRAD is greater than the specified tRAD (MAX) limit, then access time is controlled exclusively by tAA.
19. Either tRCH or tRRH must be satisfied for a READ cycle.
20. tOFF (MAX) defines the time at which the output achieves the open circuit condition, and is not referenced to V_{OH} or V_{OL}.
21. tWCS, tRWD, tAWD and tCWD are not restrictive operating parameters. tWCS applies to EARLY WRITE cycles. tRWD, tAWD and tCWD apply to READ-MODIFY-WRITE cycles. If tWCS ≥ tWCS (MIN), the cycle is an EARLY WRITE cycle and the data output will remain an open circuit throughout the entire cycle. If tRWD ≥ tRWD (MIN), tAWD ≥ tAWD (MIN) and tCWD ≥ tCWD (MIN), the cycle is a READ-MODIFY-WRITE and the data output will contain data read from the selected cell. If neither of the above conditions is met, the state of data-out is indeterminate. OE held HIGH and WE taken LOW after CAS goes LOW results in a LATE WRITE (OE-controlled) cycle. tWCS, tRWD, tCWD and tAWD are not applicable in a LATE WRITE cycle.
22. These parameters are referenced to CAS leading edge in EARLY WRITE cycles and WE leading edge in LATE WRITE or READ-MODIFY-WRITE cycles.
23. If OE is tied permanently LOW, LATE WRITE or READ-MODIFY-WRITE operations are not possible.
24. A HIDDEN REFRESH may also be performed after a WRITE cycle. In this case, WE = LOW and OE = HIGH.
25. tWTS and tWTH are setup and hold specifications for the WE pin being held LOW to enable the JEDEC test mode (with CBR timing constraints). These two parameters are the inverts of tWRP and tWRH in the CBR REFRESH cycle.
26. LATE WRITE and READ-MODIFY-WRITE cycles must have both tOD and tOE met (OE HIGH during WRITE cycle) in order to ensure that the output buffers will be open during the WRITE cycle. If OE is taken back LOW while CAS remains LOW, the DQs will remain open.
27. The DQs open during READ cycles once tOD or tOFF occur. If CAS goes HIGH before OE, the DQs will open regardless of the state of OE. If CAS stays LOW while OE is brought HIGH, the DQs will open. If OE is brought back LOW (CAS still LOW), the DQs will provide the previously read data.
28. Extended refresh current is reduced as tRAS is reduced from its maximum specification during the extended refresh cycle.
29. The 3ns minimum is a parameter guaranteed by design.
30. Column-address changed once each cycle.
31. If the DRAM controller uses a BURST REFRESH, a BURST REFRESH of all rows must be executed upon exiting SELF REFRESH.

READ CYCLE

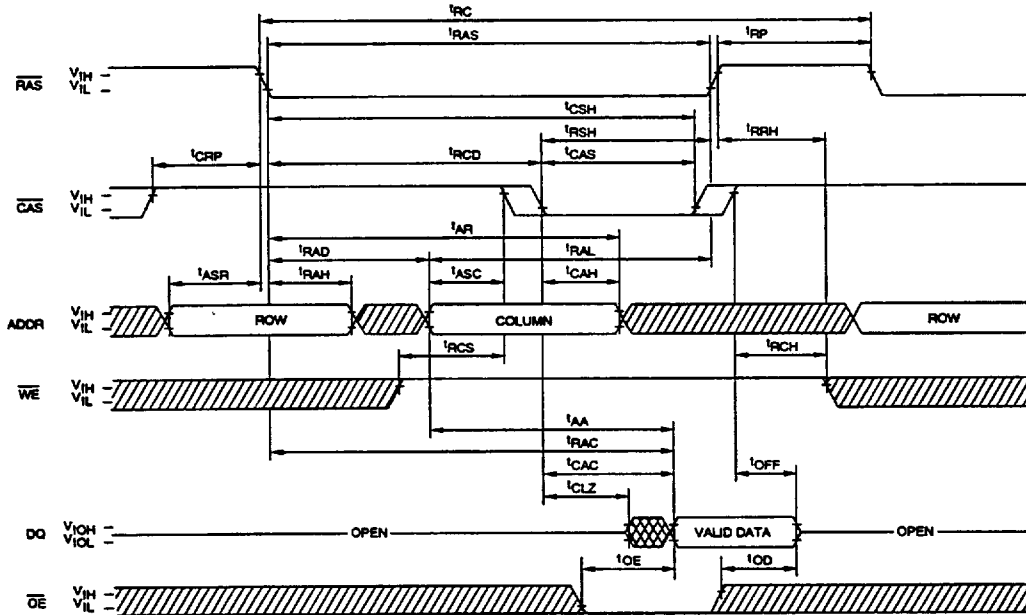

EARLY WRITE CYCLE

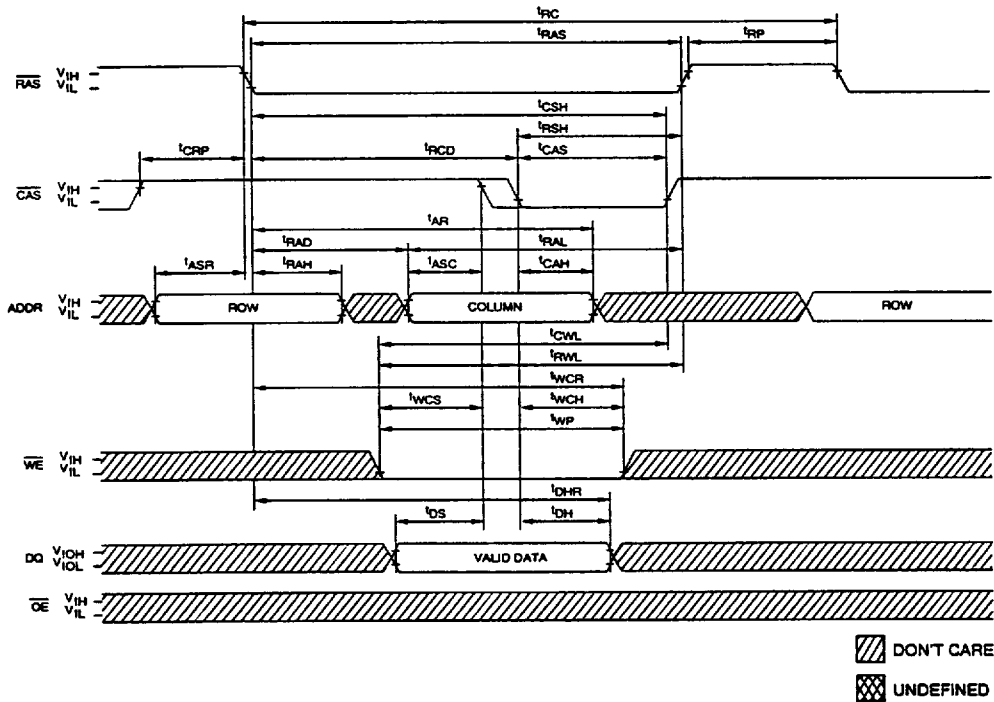

▨ DONT CARE
▩ UNDEFINED

FAST-PAGE-MODE EARLY-WRITE CYCLE

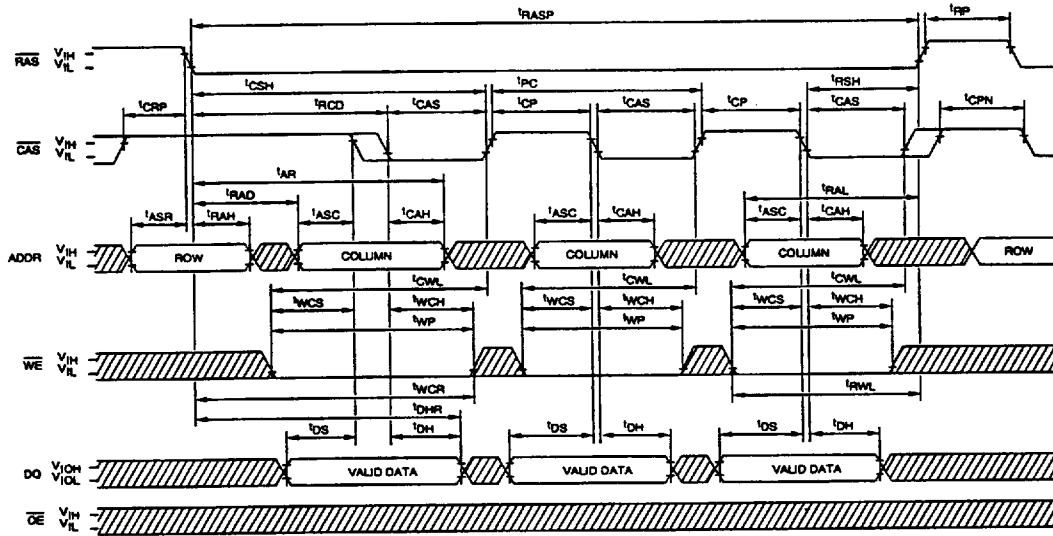

**FAST-PAGE-MODE READ-WRITE CYCLE
(LATE WRITE and READ-MODIFY-WRITE CYCLES)**

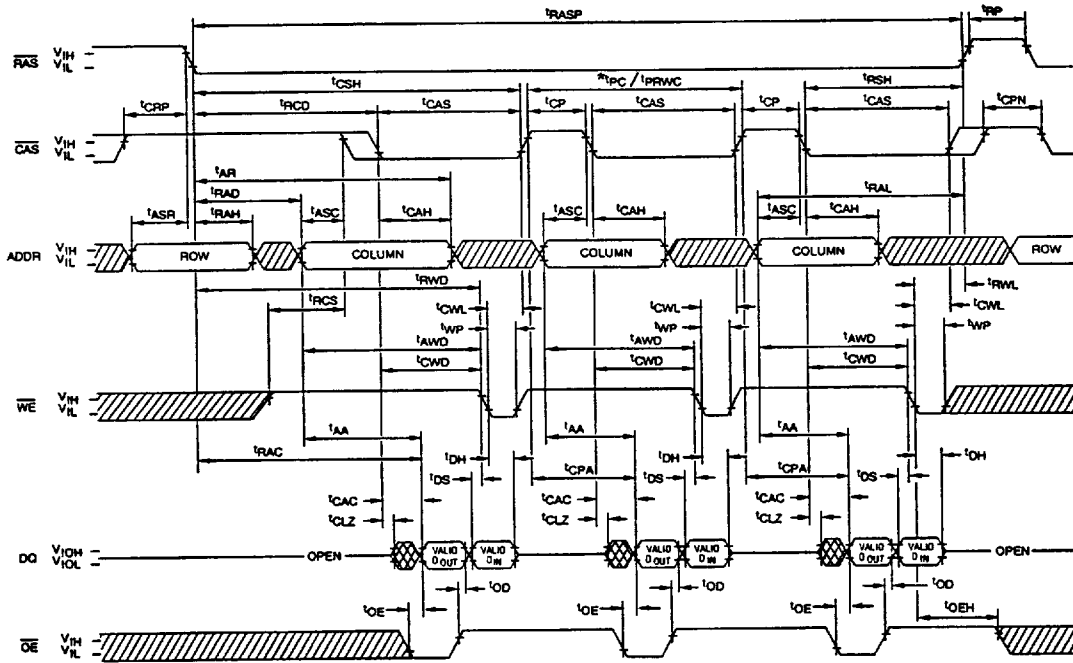

▨ DON'T CARE
▩ UNDEFINED

*tPC is for LATE WRITE only.

DRAM

RAS ONLY REFRESH CYCLE
(ADDR = A0-A9; WE = DON'T CARE)

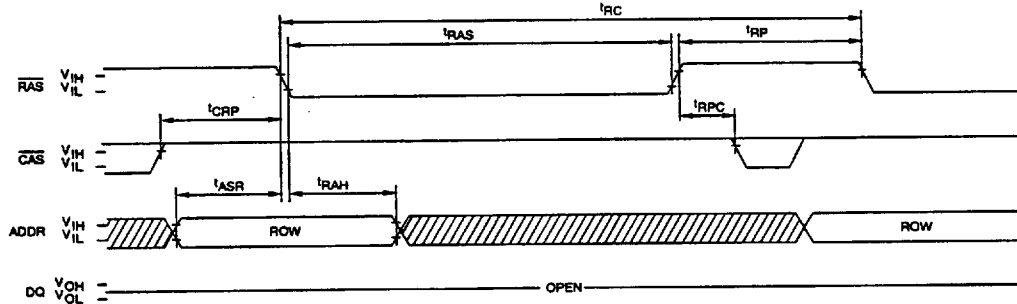

FAST-PAGE-MODE READ-EARLY-WRITE CYCLE

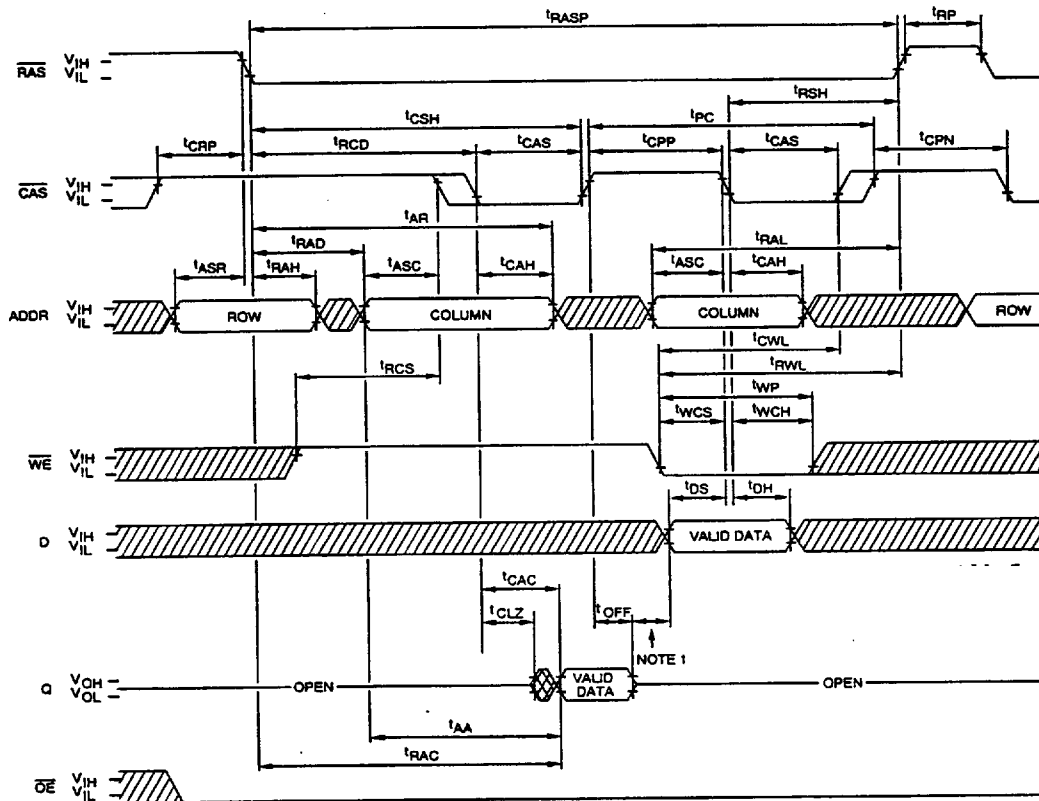

DONT CARE
 UNDEFINED

NOTE: 1. Do not drive data prior to tristate: $t_{CPP}(\text{MIN})$ or t_{CP} (whichever is greater) + $t_{DS}(\text{MIN})$ + any guardband between data-out and driving the bus with the new data-in.

CBR REFRESH CYCLE
(A0-A9 and \overline{OE} = DON'T CARE)

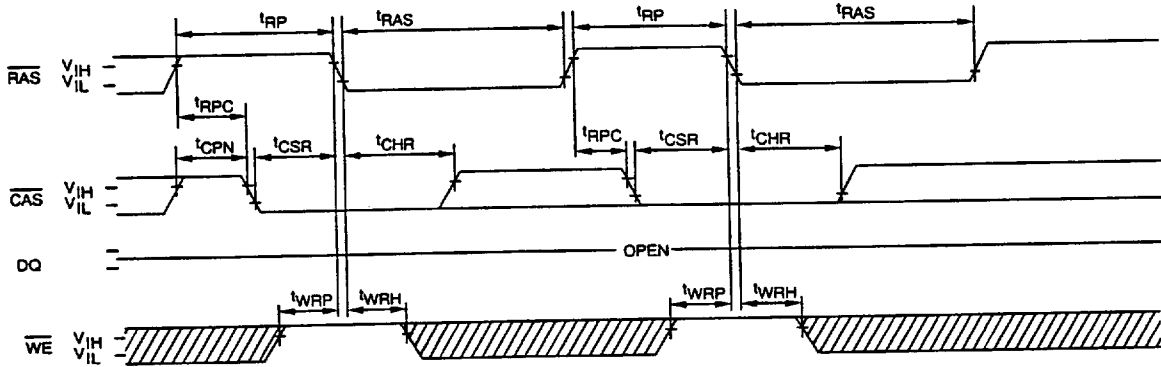

SELF REFRESH CYCLE (MT4C4001J S only)
(A0-A9 and \overline{OE} = DON'T CARE)

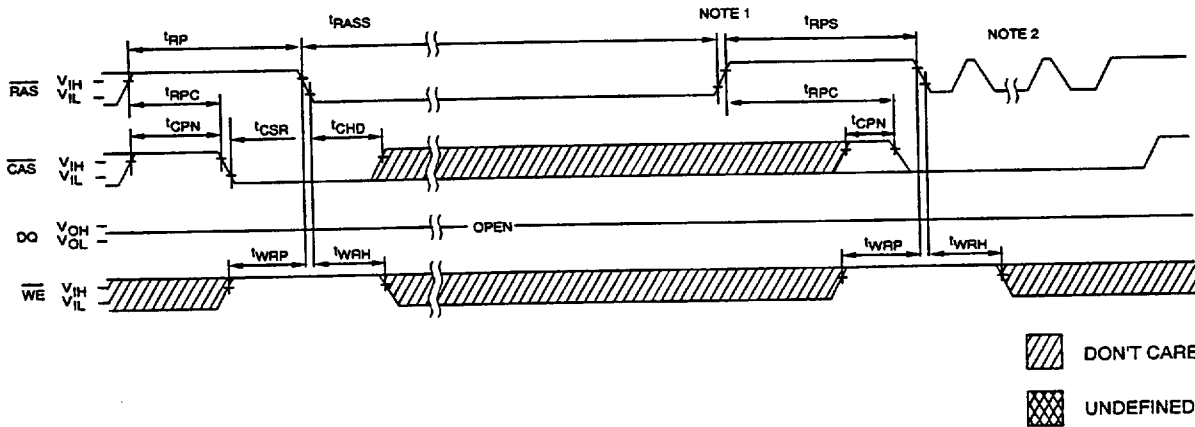

NOTE: 1. Once t_{RASS} (MIN) is met and \overline{RAS} remains LOW, the DRAM will enter SELF REFRESH mode.
2. Once t_{RPS} is satisfied, a complete burst of all rows should be executed.

DRAM

HIDDEN REFRESH CYCLE ²⁴
(\overline{WE} = HIGH; \overline{OE} = LOW)

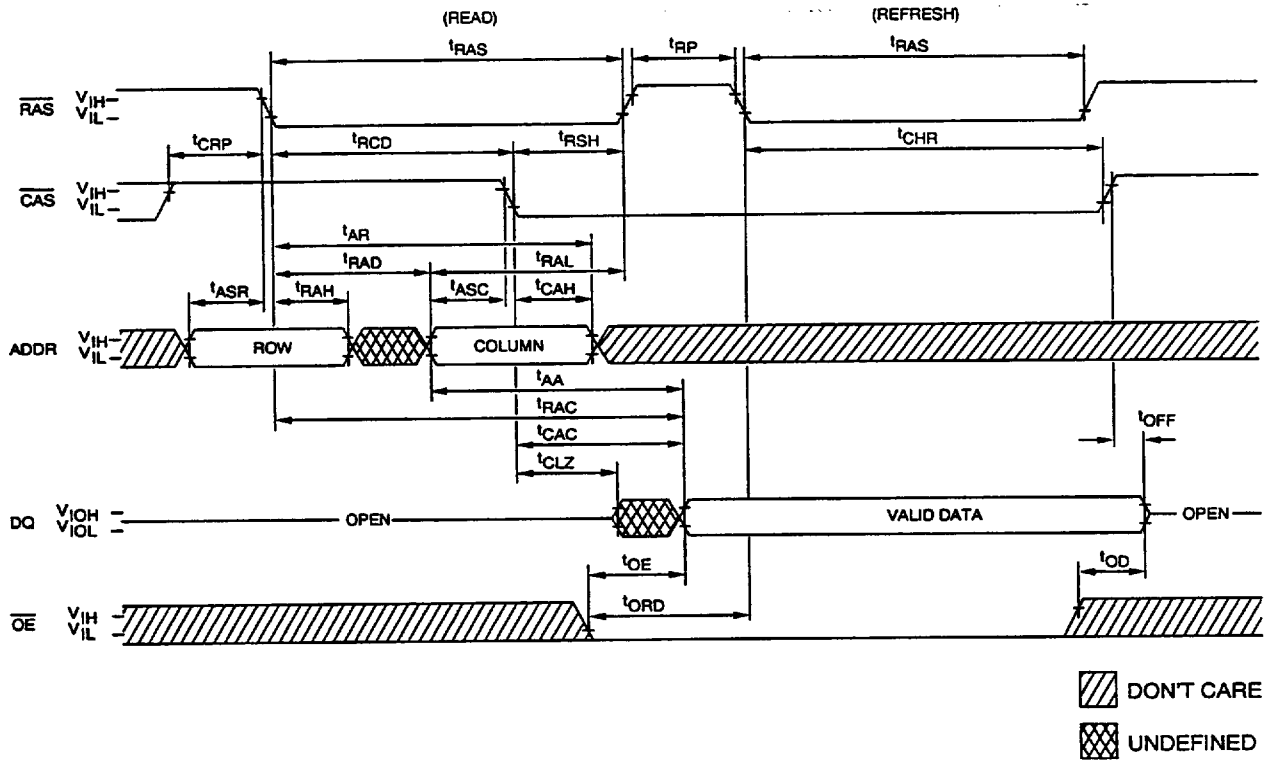

14

4 MEG POWER-UP AND REFRESH CONSTRAINTS

The EIA/JEDEC 4 Meg DRAM introduces two potential incompatibilities compared to the previous generation 1 Meg DRAM. The incompatibilities involve refresh and power-up. Understanding these incompatibilities and providing for them will offer the designer and system user greater compatibility between the 1 Meg and 4 Meg.

REFRESH

The most commonly used refresh cycle of the 1 Meg is the CBR REFRESH cycle. The CBR for the 1 Meg specifies the \overline{WE} pin as a "don't care." The 4 Meg, on the other hand, specifies the CBR REFRESH mode with the \overline{WE} pin held at a voltage HIGH level.

A CBR cycle with \overline{WE} LOW will put the 4 Meg into the JEDEC-specified test mode (WCBR).

POWER-UP

The 4 Meg JEDEC test mode constraint may introduce another problem. The 1 Meg POWER-UP cycle requires a 100 μ s delay followed by any eight \overline{RAS} cycles. The 4 Meg POWER-UP is more restrictive in that eight \overline{RAS} ONLY or CBR REFRESH (\overline{WE} held HIGH) cycles must be used. The restriction is needed since the 4 Meg may power-up in the JEDEC-specified test mode and must exit out of the test mode. The only way to exit the 4 Meg JEDEC test mode is with either a \overline{RAS} ONLY or a CBR REFRESH cycle (\overline{WE} held HIGH).

SUMMARY

1. The 1 Meg CBR REFRESH allows the \overline{WE} pin to be "don't care" while the 4 Meg CBR requires \overline{WE} to be HIGH.
2. The eight \overline{RAS} wake-up cycles on the 1 Meg may be any valid \overline{RAS} cycle while the 4 Meg may only use \overline{RAS} ONLY or CBR REFRESH cycles (\overline{WE} held HIGH).

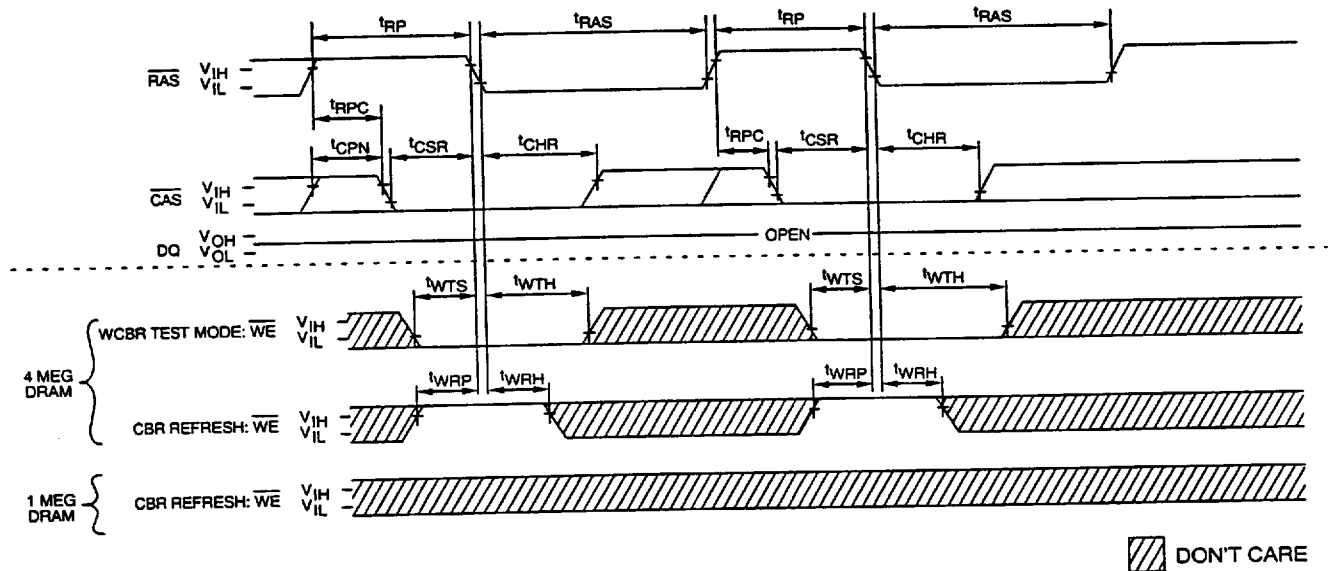

COMPARISON OF 4 MEG TEST MODE AND WCBR TO 1 MEG CBR