



September 1999
Revised November 1999

NC7SB3157

TinyLogic™ Low Voltage UHS Analog Switch 2-Channel Multiplexer/Demultiplexer (Preliminary)

General Description

The NC7SB3157 is a high performance, Analog Switch 2-channel CMOS multiplexer/demultiplexer from Fairchild's Ultra High Speed Series of TinyLogic™. The device is fabricated with advanced sub-micron CMOS technology to achieve high speed enable and disable times and low on resistance. The break before make select circuitry prevents disruption of signals on the B Port due to both switches temporarily being enabled during select pin switching. The device is specified to operate over the 1.65 to 5.5V V_{CC} operating range. The control input tolerates voltages up to 5.5V independent of the V_{CC} operating range.

Features

- Useful in both analog and digital applications
- Space saving SC70 6-lead surface mount package
- Low on resistance; < 10Ω on typ @ 3.3V V_{CC}
- Broad V_{CC} operating range; 1.65V to 5.5V
- Power down high impedance control input
- Overvoltage tolerance of control input to 7.0V
- Break before make enable circuitry

Ordering Code:

Order Number	Package Number	Package Top Mark	Package Description	Supplied As
NC7SB3157P6X	MAA06A	B7A	6-Lead SC70, EIAJ SC88, 1.25mm Wide	3k Units on Tape and Reel

Logic Symbol

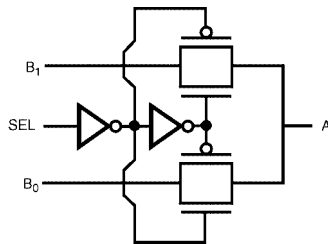

Connection Diagram

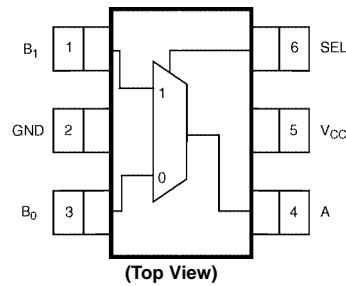

Pin Descriptions

Pin Names	Description
A, B ₀ , B ₁	Data Ports
SEL	Control Input

Pin One Orientation Diagram

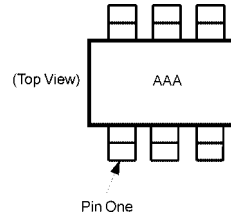

AAA = Package Top Mark - see ordering code.

Note: Orientation of Top Mark determines Pin One location. Read the top package mark left to right, Pin One is the lower left pin (see diagram).

Function Table

Input (SEL)	Function
L	B ₀ Connected to A
H	B ₁ Connected to A

H = HIGH Logic Level
L = LOW Logic Level

TinyLogic™ is a trademark of Fairchild Semiconductor Corporation.

NC7SB3157 TinyLogic™ Low Voltage UHS Analog Switch 2-Channel Multiplexer/Demultiplexer (Preliminary)

NC7SB3157

Absolute Maximum Ratings(Note 1)

Supply Voltage (V_{CC})	-0.5V to +7.0V
DC Switch Voltage (V_S) (Note 2)	-0.5V to V_{CC} +0.5V
DC Input Voltage (V_{IN}) (Note 2)	-0.5V to +7.0V
DC Input Diode Current (I_{IK}) @ (I_{IK}) $V_{IN} < 0V$	-50 mA
DC Output Current (I_{OUT})	128 mA
DC V_{CC} or Ground Current (I_{CC}/I_{GND})	± 100 mA
Storage Temperature Range (T_{STG})	-65°C to +150°C
Junction Temperature under Bias (T_J)	150°C
Junction Lead Temperature (T_L) (Soldering, 10 seconds)	260°C
Power Dissipation (P_D) @ +85°C	180 mW

Recommended Operating Conditions (Note 3)

Supply Voltage Operating (V_{CC})	1.65V to 5.5V
Control Input Voltage (V_{IN})	0V to V_{CC}
Switch Input Voltage (V_{IN})	0V to V_{CC}
Output Voltage (V_{OUT})	0V to V_{CC}
Operating Temperature (T_A)	-40°C to +85°C
Input Rise and Fall Time (t_r, t_f)	
Control Input $V_{CC} = 2.3V - 3.6V$	0 ns/V to 10 ns/V
Control Input $V_{CC} = 4.5V - 5.5V$	0 ns/V to 5 ns/V
Thermal Resistance (θ_{JA})	350°C/W

Note 1: Absolute maximum ratings are DC values beyond which the device may be damaged or have its useful life impaired. The datasheet specifications should be met, without exception, to ensure that the system design is reliable over its power supply, temperature, and output/input loading variables. Fairchild does not recommend operation outside datasheet specifications.

Note 2: The input and output negative voltage ratings may be exceeded if the input and output diode current ratings are observed.

Note 3: Control input must be held HIGH or LOW, it must not float.

DC Electrical Characteristics

Symbol	Parameter	V_{CC} (V)	$T_A = +25^\circ C$			$T_A = -40^\circ C$ to $+85^\circ C$		Units	Conditions		
			Min	Typ	Max	Min	Max				
V_{IH}	HIGH Level Input Voltage	1.65 – 1.95 2.3 – 5.5	0.75 V_{CC} 0.7 V_{CC}			0.75 V_{CC} 0.7 V_{CC}		V			
V_{IL}	LOW Level Input Voltage	1.65 – 1.95 2.3 – 5.5			0.25 V_{CC} 0.3 V_{CC}	0.25 V_{CC} 0.3 V_{CC}		V			
I_{IN}	Input Leakage Current	0 – 5.5			± 0.1	± 1		μA	$0 \leq V_{IN} \leq 5.5V$		
I_{OFF}	OFF State Leakage Current	1.65 – 5.5			± 0.1	± 1		μA	$0 \leq A, B \leq V_{CC}$		
R_{ON}	Switch ON Resistance (Note 4)	4.5		3	7		7	Ω	$V_{IN} = 0V, I_{IN} = 30 mA$		
				5	12		12	Ω	$V_{IN} = 2.4V, I_{IN} = 30 mA$		
				7	15		15	Ω	$V_{IN} = 4.5V, I_{IN} = 30 mA$		
		3.0		4	9		9	Ω	$V_{IN} = 0V, I_{IN} = 24 mA$		
				10	20		20	Ω	$V_{IN} = 3V, I_{IN} = 24 mA$		
				5	12		12	Ω	$V_{IN} = 0V, I_{IN} = 8 mA$		
		1.65								Ω	$V_{IN} = 2.3V, I_{IN} = 8 mA$
				TBD	TBD		TBD			Ω	$V_{IN} = 0V, I_{IN} = 4 mA$
								Ω	$V_{IN} = 1.65V, I_{IN} = 4 mA$		
I_{CC}	Quiescent Supply Current All Channels ON or OFF	5.5			1	10		μA	$V_{IN} = V_{CC}$ or GND $I_{OUT} = 0$		
	Analog Signal Range	V_{CC}	0		V_{CC}	0	V_{CC}	V			
R_{RANGE}	ON Resistance	1.65						Ω	$I_A = -4 mA, 0 \leq V_{Bn} \leq V_{CC}$		
	Over Signal Range (Note 4)(Note 5)	2.3					$I_A = -8 mA, 0 \leq V_{Bn} \leq V_{CC}$				
		3.0					$I_A = -24 mA, 0 \leq V_{Bn} \leq V_{CC}$				
		4.5					$I_A = -30 mA, 0 \leq V_{Bn} \leq V_{CC}$				
ΔR_{ON}	ON Resistance Match Between Channels (Note 4)(Note 5)(Note 6)	1.65						Ω	$I_A = -4 mA, V_{Bn} = 1.15$		
		2.3					$I_A = -8 mA, V_{Bn} = 1.6$				
		3.0					$I_A = -24 mA, V_{Bn} = 2.1$				
		4.5					$I_A = -30 mA, V_{Bn} = 3.15$				

DC Electrical Characteristics (Continued)										
Symbol	Parameter	V _{CC} (V)	T _A = +25°C			T _A = -40°C to +85°C		Units	Conditions	
			Min	Typ	Max	Min	Max			
R _{flat}	On Resistance Flatness (Note 4)(Note 5)(Note 7)	1.8					Ω	I _A = -4 mA 0 ≤ V _{Bn} ≤ V _{CC}		
		2.5						I _A = -8 mA 0 ≤ V _{Bn} ≤ V _{CC}		
		3.3						I _A = -24 mA 0 ≤ V _{Bn} ≤ V _{CC}		
		5.0						I _A = -30 mA 0 ≤ V _{Bn} ≤ V _{CC}		
I _{B-OFF}	OFF Leakage Current	5.5			±0.1		±1	μA	V _A = 1.0V or 4.5V V _{Bn} = 4.5V or 1V	
I _{A-OFF}	OFF Leakage Current	5.5			±0.1			±1	μA	V _A = 4.5V or 1.0V V _{Bn} = 1.0V or 4.5V
<p>Note 4: Measured by the voltage drop between A and B pins at the indicated current through the switch. On resistance is determined by the lower of the voltages on the two (A or B Ports).</p> <p>Note 5: Parameter is characterized but not tested in production.</p> <p>Note 6: ΔR_{ON} = R_{ON} max - R_{ON} min measured at identical V_{CC}, temperature and voltage levels.</p> <p>Note 7: Flatness is defined as the difference between the maximum and minimum value of on resistance over the specified range of conditions.</p>										
AC Electrical Characteristics										
Symbol	Parameter	V _{CC} (V)	T _A = +25°C			T _A = -40°C to +85°C		Units	Conditions	Fig. No.
			Min	Typ	Max	Min	Max			
t _{PHL}	Propagation Delay	1.65 - 1.95			TBD			ns	V _I = OPEN	Figure 1 Figure 2
t _{PLH}	Bus to Bus (Note 9)	2.3 - 2.7			1.2		1.2			
		3.0 - 3.6			0.8		0.8			
		4.5 - 5.5			0.3		0.3			
t _{PZL}	Output Enable Time	1.65 - 1.95			TBD			ns	V _I = 2 x V _{CC} for t _{PZL} V _I = 0V for t _{PZH}	Figure 1 Figure 2
t _{PZH}	Turn on Time (A to B- or B- to A)	2.3 - 2.7			15		15			
		3.0 - 3.6			10		10			
		4.5 - 5.5			7		7			
t _{PLZ}	Output Enable Time	1.65 - 1.95			TBD			ns	V _I = 2 x V _{CC} for t _{PLZ} V _I = 0V for t _{PHZ}	Figure 1 Figure 2
t _{PHZ}	Turn Off Time (A Port to B Port)	2.3 - 2.7			8		8			
		3.0 - 3.6			6		6			
		4.5 - 5.5			4		4			
t _{B-M}	Break Before Make Time (Note 8)	1.65 - 1.95	0.5		TBD	0.5	TBD	ns		Figure 3
		2.3 - 2.7	0.5		TBD	0.5	TBD			
		3.0 - 3.6	0.5		TBD	0.5	TBD			
		4.5 - 5.5	0.5		TBD	0.5	TBD			
Q	Charge Injection (Note 8)				TBD			pC	C _L = 1 nF, V _{GEN} = 0V R _{GEN} = 0Ω	Figure 4
OIRR	Off Isolation (Note 10)				TBD			dB	R _L = 50Ω, C _L = 5 pF f = 10MHz	Figure 5
Xtalk	Crosstalk				TBD			dB	R _L = 50Ω, C _L = 5 pF f = 10MHz	Figure 6
BW	-3dB Bandwidth				TBD			MHz	R _L = 50Ω	Figure 9
<p>Note 8: Guaranteed by Design.</p> <p>Note 9: This parameter is guaranteed by design but not tested. The bus switch contributes no propagation delay other than the RC delay of the on resistance of the switch and the 50 pF load capacitance, when driven by an ideal voltage source (zero output impedance).</p> <p>Note 10: Off Isolation = 20 log₁₀ [V_A / V_{Bn}]</p>										

Capacitance (Note 11)

Symbol	Parameter	Typ	Max	Units	Conditions	Figures
C_{IN}	Control Pin Input Capacitance	2	TBD	pF	$V_{CC} = 0V$	
C_{IO-B}	B Port Off Capacitance	6	TBD	pF	$V_{CC} = 5.0V$	Figure 7
C_{IOA-ON}	A Port Capacitance when switch is enabled		TBD	pF	$V_{CC} = 5.0V$	Figure 8

Note 11: $T_A = +25^{\circ}C$, $f = 1\text{ MHz}$, Capacitance is characterized but not tested in production.

AC Loading and Waveforms

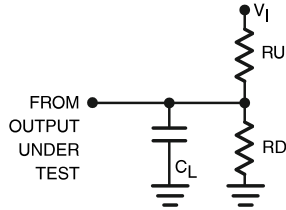

Note: Input driven by 50Ω source terminated in 50Ω
 Note: C_L includes load and stray capacitance
 Note: Input PRR = 1.0 MHz; $t_W = 500\text{ ns}$

FIGURE 1. AC Test Circuit

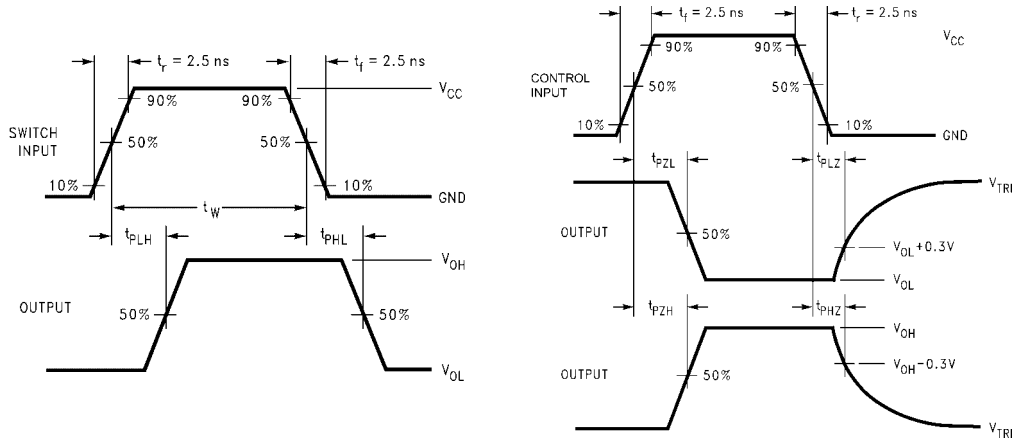

FIGURE 2. AC Waveforms

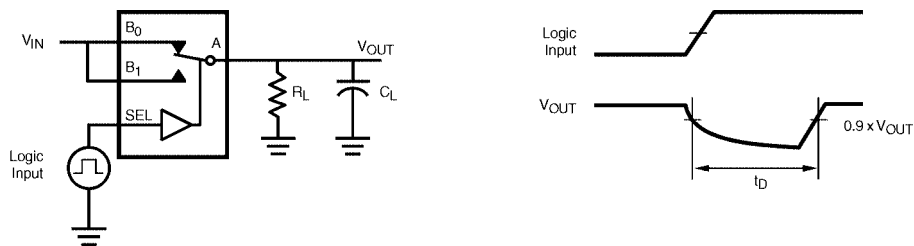

FIGURE 3. Break Before Make Interval Timing

AC Loading and Waveforms (Continued)

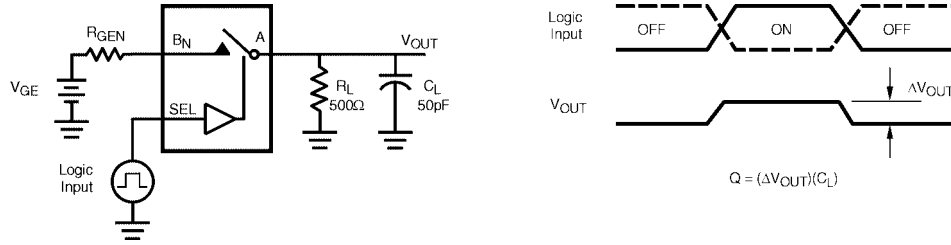

FIGURE 4. Charge Injection Test

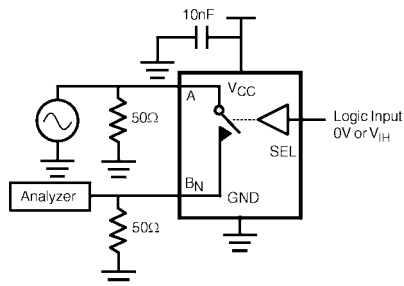

FIGURE 5. Off Isolation

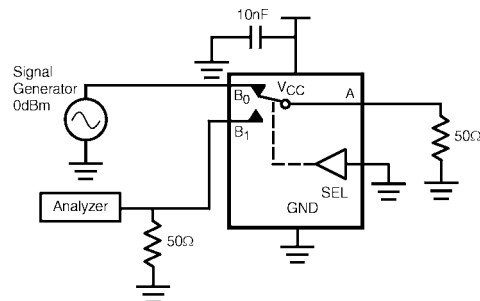

FIGURE 6. Crosstalk

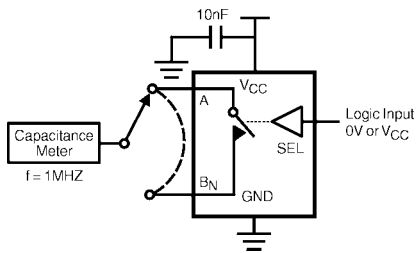

FIGURE 7. Channel Off Capacitance

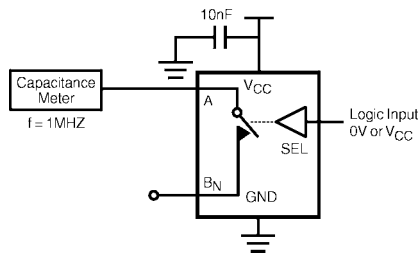

FIGURE 8. Channel On Capacitance

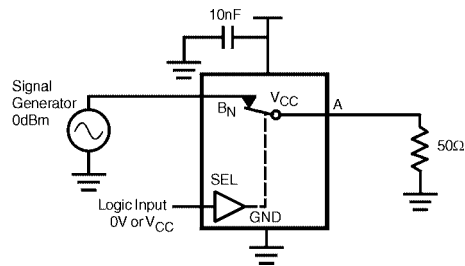

FIGURE 9. Bandwidth

NC7SB3157

Tape and Reel Specification

TAPE FORMAT

Package Designator	Tape Section	Number Cavities	Cavity Status	Cover Tape Status
P6X	Leader (Start End)	125 (typ)	Empty	Sealed
	Carrier	3000	Filled	Sealed
	Trailer (Hub End)	75 (typ)	Empty	Sealed

TAPE DIMENSIONS inches (millimeters)

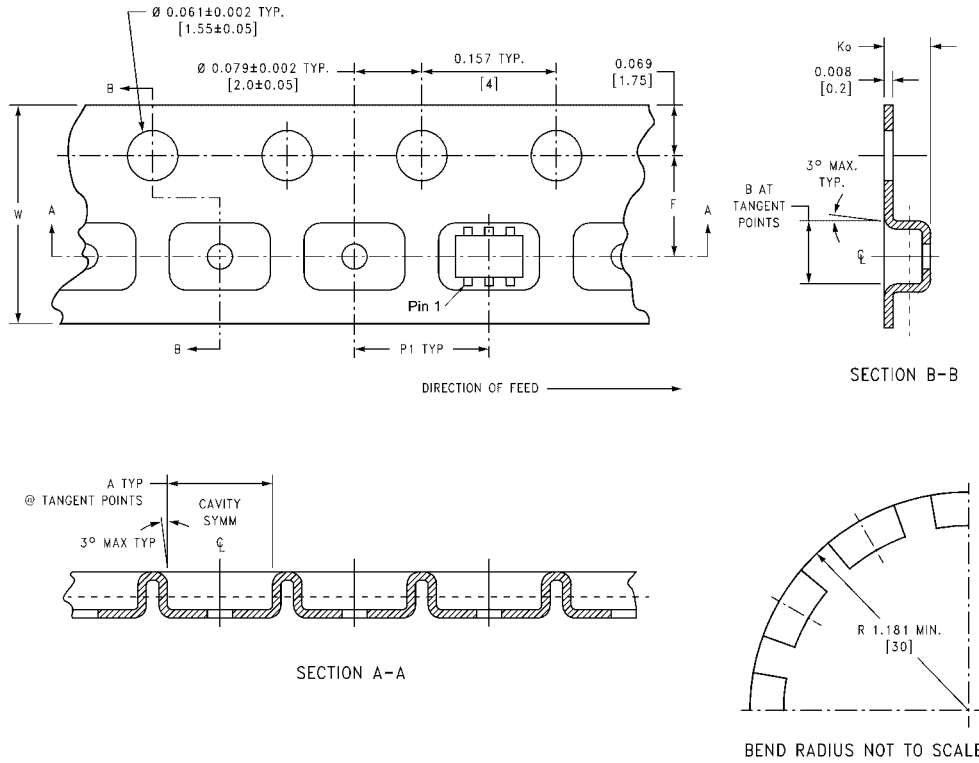

Package	Tape Size	DIM A	DIM B	DIM F	DIM K ₀	DIM P1	DIM W
SC70-6	8 mm	0.093 (2.35)	0.096 (2.45)	0.138 ± 0.004 (3.5 ± 0.10)	0.053 ± 0.004 (1.35 ± 0.10)	0.157 (4)	0.315 ± 0.004 (8 ± 0.1)

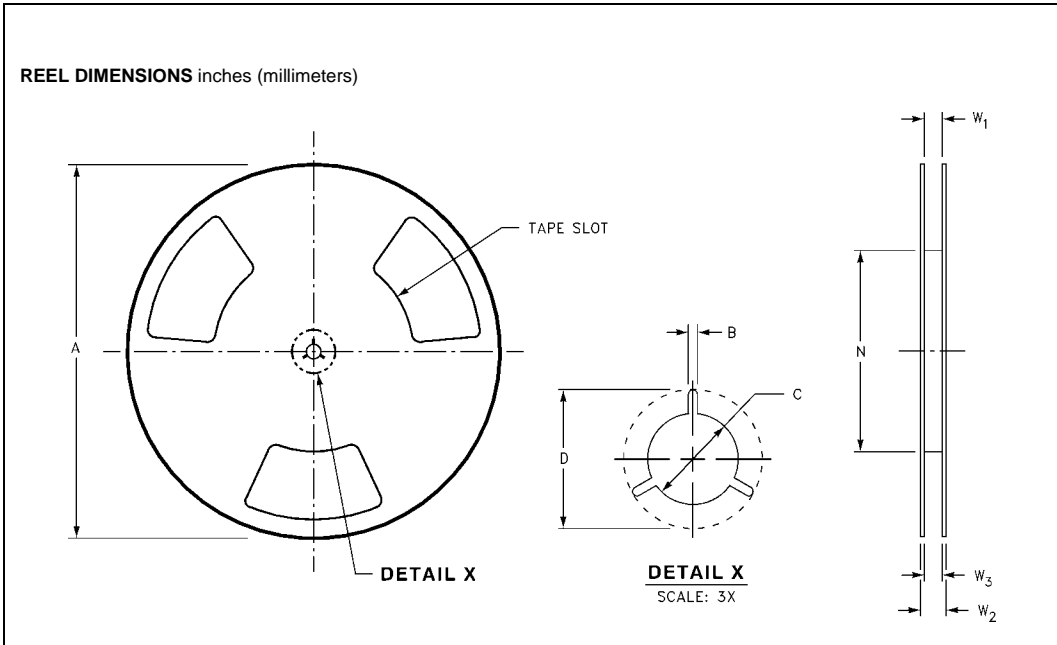

Tape Size	A	B	C	D	N	W1	W2	W3
8 mm	7.0 (177.8)	0.059 (1.50)	0.512 (13.00)	0.795 (20.20)	2.165 (55.00)	0.331 + 0.059/-0.000 (8.40 + 1.50/-0.00)	0.567 (14.40)	W1 + 0.078/-0.039 (W1 + 2.00/-1.00)

Physical Dimensions inches (millimeters) unless otherwise noted

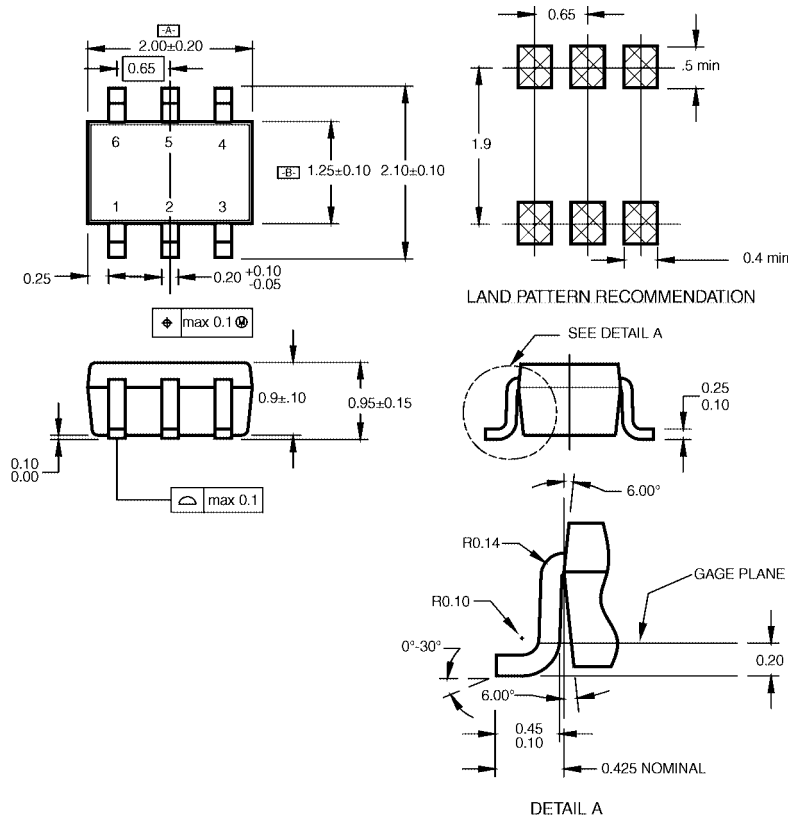

- NOTES:
- A. CONFORMS TO EIAJ REGISTERED OUTLINE DRAWING SC88.
 - B. DIMENSIONS DO NOT INCLUDE BURRS OR MOLD FLASH.
 - C. DIMENSIONS ARE IN MILLIMETERS.

**6-Lead SC70, EIAJ SC88, 1.25mm Wide
Package Number MAA06A**

Fairchild does not assume any responsibility for use of any circuitry described, no circuit patent licenses are implied and Fairchild reserves the right at any time without notice to change said circuitry and specifications.

LIFE SUPPORT POLICY

FAIRCHILD'S PRODUCTS ARE NOT AUTHORIZED FOR USE AS CRITICAL COMPONENTS IN LIFE SUPPORT DEVICES OR SYSTEMS WITHOUT THE EXPRESS WRITTEN APPROVAL OF THE PRESIDENT OF FAIRCHILD SEMICONDUCTOR CORPORATION. As used herein:

1. Life support devices or systems are devices or systems which, (a) are intended for surgical implant into the body, or (b) support or sustain life, and (c) whose failure to perform when properly used in accordance with instructions for use provided in the labeling, can be reasonably expected to result in a significant injury to the user.
2. A critical component in any component of a life support device or system whose failure to perform can be reasonably expected to cause the failure of the life support device or system, or to affect its safety or effectiveness.

www.fairchildsemi.com