



September 1999  
Revised November 1999

# NC7SZ19

## TinyLogic™ UHS 1-of-2 Decoder/Demultiplexer (Preliminary)

### General Description

The NC7SZ19 is a 1-of-2 decoder with a common output enable. The device is fabricated with advanced CMOS technology to achieve ultra high speed with high output drive while maintaining low static power dissipation over a broad  $V_{CC}$  operating range. The device is specified to operate over the 1.65V to 5.5V  $V_{CC}$  operating range. The inputs and outputs are high impedance when  $V_{CC}$  is 0V. Inputs tolerate voltages up to 5.5V independent of  $V_{CC}$  operating range.

### Features

- Space saving SC70 6-lead surface mount package
- Ultra High Speed:  $t_{PD}$  3.5 ns Typ into 50 pF at 5V  $V_{CC}$
- Broad  $V_{CC}$  Operating Range; 1.65V to 5.5V
- Power down high impedance inputs/outputs
- Overvoltage tolerant inputs facilitate 5V to 3V translation
- Patented noise/EMI reduction circuitry implemented

### Ordering Code:

Order Number	Package Number	Package Top Mark	Package Description	Supplied As
NC7SZ19P6X	MAA06A	Z19	6-Lead SC70, EIAJ SC88, 1.25mm Wide	3k Units on Tape and Reel

### Pin Descriptions

Pin Names	Description
$\bar{E}$	Decoder Output Enable/ Demultiplexer Data
A	Decoder Address/Demultiplexer Select
$Y_0, Y_1$	Outputs

### Function Table

Input		Output	
A	$\bar{E}$	$Y_0 = A + \bar{E}$	$Y_1 = \bar{A} + \bar{E}$
L	L	L	H
H	L	H	L
X	H	H	H

H = HIGH Logic Level  
L = LOW Logic Level  
X = Don't Care

### Connection Diagram

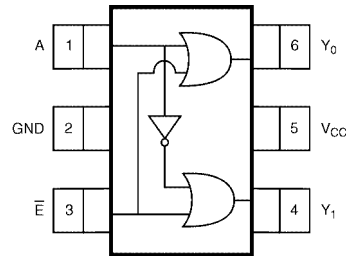

(Top View)

### Pin One Orientation Diagram

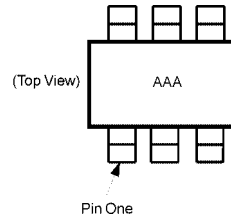

AAA = Package Top Mark - see ordering code

**Note:** Orientation of Top Mark determines Pin One location. Read the top package mark left to right, Pin One is the lower left pin (see diagram).

TinyLogic™ is a trademark of Fairchild Semiconductor Corporation.

NC7SZ19

**Absolute Maximum Ratings**(Note 1)

Supply Voltage ( $V_{CC}$ )	-0.5V to +7.0V
DC Input Voltage ( $V_{IN}$ )	-0.5V to +7.0V
DC Output Voltage ( $V_{OUT}$ )	-0.5V to +7.0V
DC Input Diode Current ( $I_{IK}$ )	
@ $V_{IN} \leq -0.5V$	-20 mA
@ $V_{IN} \leq V_{CC} + 0.5V$	20 mA
DC Output Diode Current ( $I_{OK}$ )	
@ $V_{IN} \leq -0.5V$	-20 mA
@ $V_{IN} \leq V_{CC} + 0.5V$	20 mA
DC Output Current ( $I_{OUT}$ )	$\pm 50$ mA
DC $V_{CC}$ or Ground Current ( $I_{CC}/I_{GND}$ )	$\pm 50$ mA
Storage Temperature Range ( $T_{STG}$ )	-65°C to +150°C
Junction Temperature under Bias ( $T_J$ )	150°C
Junction Lead Temperature ( $T_L$ )	
(Soldering, 10 seconds)	260°C
Power Dissipation ( $P_D$ ) @ +85°C	180 mW

**Recommended Operating Conditions**

Supply Voltage Operating ( $V_{CC}$ )	1.65V to 5.5V
Supply Voltage Data Retention ( $V_{CC}$ )	1.5V to 5.5V
Input Voltage ( $V_{IN}$ )	0V to $V_{CC}$
Output Voltage ( $V_{OUT}$ )	0V to $V_{CC}$
Operating Temperature ( $T_A$ )	-40°C to +85°C
Input Rise and Fall Time ( $t_r, t_f$ )	
$V_{CC}$ @ 1.8V $\pm$ 0.15V, 2.5V $\pm$ 0.2V	0 ns/V to 20 ns/V
$V_{CC}$ @ 3.3V $\pm$ 0.3V	0 ns/V to 10 ns/V
$V_{CC}$ @ 5.0V $\pm$ 0.5V	0 ns/V to 5 ns/V
Thermal Resistance ( $\theta_{JA}$ )	350°C/W

**Note 1:** Absolute maximum ratings are DC values beyond which the device may be damaged or have its useful life impaired. The datasheet specifications should be met, without exception, to ensure that the system design is reliable over its power supply, temperature, and output/input loading variables. Fairchild does not recommend operation outside datasheet specifications.

**DC Electrical Characteristics**

Symbol	Parameter	$V_{CC}$ (V)	$T_A = +25^\circ C$			$T_A = -40^\circ C$ to $+85^\circ C$		Units	Conditions	
			Min	Typ	Max	Min	Max			
$V_{IH}$	HIGH Level Input Voltage	1.65	0.75 $V_{CC}$			0.75 $V_{CC}$		V		
		2.3 – 5.5	0.7 $V_{CC}$			0.7 $V_{CC}$				
$V_{IL}$	LOW Level Input Voltage	1.65	0.25 $V_{CC}$			0.25 $V_{CC}$		V		
		2.3 – 5.5	0.3 $V_{CC}$			0.3 $V_{CC}$				
$V_{OH}$	HIGH Level Output Voltage	1.65	1.55	1.65	1.55		V	$V_{IN} = V_{IH}$ or $V_{IL}$	$I_{OH} = -100 \mu A$	
		2.3	2.2	2.3	2.2					
		3.0	2.9	3.0	2.9					
		4.5	4.4	4.5	4.4					
		2.3	1.9	2.15	1.9				$I_{OH} = -8 \text{ mA}$ $I_{OH} = -16 \text{ mA}$ $I_{OH} = -24 \text{ mA}$ $I_{OH} = -32 \text{ mA}$	
		3.0	2.4	2.80	2.4					
		3.0	2.3	3.68	2.3					
		4.5	3.8	4.20	3.8					
$V_{OL}$	LOW Level Output Voltage	1.65	0.0			0.10		V	$V_{IN} = V_{IL}$ or $V_{IH}$	$I_{OL} = 100 \mu A$
		2.3	0.0			0.10				
		3.0	0.0			0.10				
		4.5	0.0			0.10				
		2.3	0.10		0.3	0.3				$I_{OL} = 8 \text{ mA}$ $I_{OL} = 16 \text{ mA}$ $I_{OL} = 24 \text{ mA}$ $I_{OL} = 32 \text{ mA}$
		3.0	0.15		0.4	0.4				
		3.0	0.22		0.55	0.55				
4.5	0.22		0.55	0.55						
$I_{IN}$	Input Leakage Current	0 to 5.5				$\pm 0.1$		$\mu A$	$V_{IN} = 5.5V, GND$	
$I_{OFF}$	Power Off Leakage Current	0.0				1		$\mu A$	$V_{IN}$ or $V_{OUT} = 5.5V$	
$I_{CC}$	Quiescent Supply Current	1.65 to 5.5				1		$\mu A$	$V_{IN} = 5.5V, GND$	

### AC Electrical Characteristics

Symbol	Parameter	V <sub>CC</sub> (V)	T <sub>A</sub> = +25°C			T <sub>A</sub> = -40°C to +85°C		Units	Conditions	Fig. No.
			Min	Typ	Max	Min	Max			
t <sub>PLH</sub>	Propagation Delay A or $\bar{E}$ to Output	1.8 ± 0.15				12.2	ns	C <sub>L</sub> = 15 pF, R <sub>L</sub> = 1 MΩ	Figure 1	
t <sub>PHL</sub>		2.5 ± 0.2				8.4				Figure 3
		3.3 ± 0.3				6.1				
		5.0 ± 0.5				5.4				
t <sub>PLH</sub>	Propagation Delay A or $\bar{E}$ to Output	3.3 ± 0.3				7.0	ns	C <sub>L</sub> = 50 pF, R <sub>L</sub> = 500Ω	Figure 1	
t <sub>PHL</sub>		5.0 ± 0.5				6.0				Figure 3
C <sub>IN</sub>	Input Capacitance	0	4				pF			
C <sub>PD</sub>	Power Dissipation Capacitance	3.3 5.0	TBD	TBD			pF	(Note 2)	Figure 2	

**Note 2:** C<sub>PD</sub> is defined as the value of the internal equivalent capacitance which is derived from dynamic operating current consumption (I<sub>CCD</sub>) at no output loading and operating at 50% duty cycle. (See Figure 2.) C<sub>PD</sub> is related to I<sub>CCD</sub> dynamic operating current by the expression:  
 $I_{CCD} = (C_{PD})(V_{CC})(f_{IN}) + I_{CCstatic}$ .

### AC Loading and Waveforms

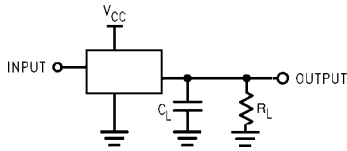

C<sub>L</sub> includes load and stray capacitance  
 Input PRR = 1.0 MHz; t<sub>W</sub> = 500 ns

**FIGURE 1. AC Test Circuit**

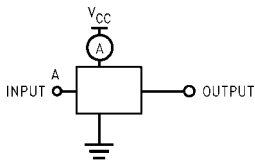

Input = AC Waveform; t<sub>r</sub> = t<sub>f</sub> = 1.8 ns  
 PRR = 10 MHz; Duty Cycle = 50%  
 $\bar{E}$  Input = GND

**FIGURE 2. I<sub>CCD</sub> Test Circuit**

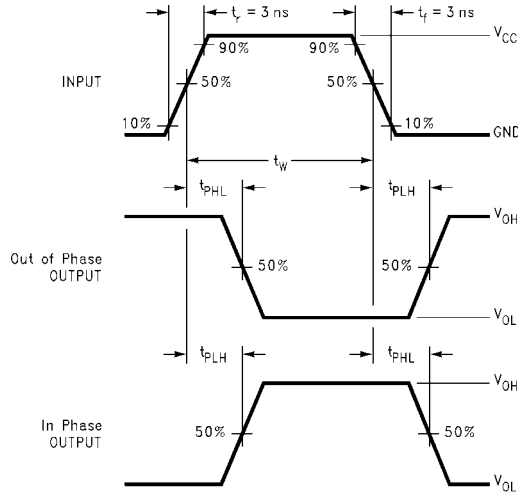

**FIGURE 3. AC Waveforms**

NC7SZ19

**Tape and Reel Specification**

**TAPE FORMAT**

Package Designator	Tape Section	Number Cavities	Cavity Status	Cover Tape Status
P6X	Leader (Start End)	125 (typ)	Empty	Sealed
	Carrier	3000	Filled	Sealed
	Trailer (Hub End)	75 (typ)	Empty	Sealed

**TAPE DIMENSIONS** inches (millimeters)

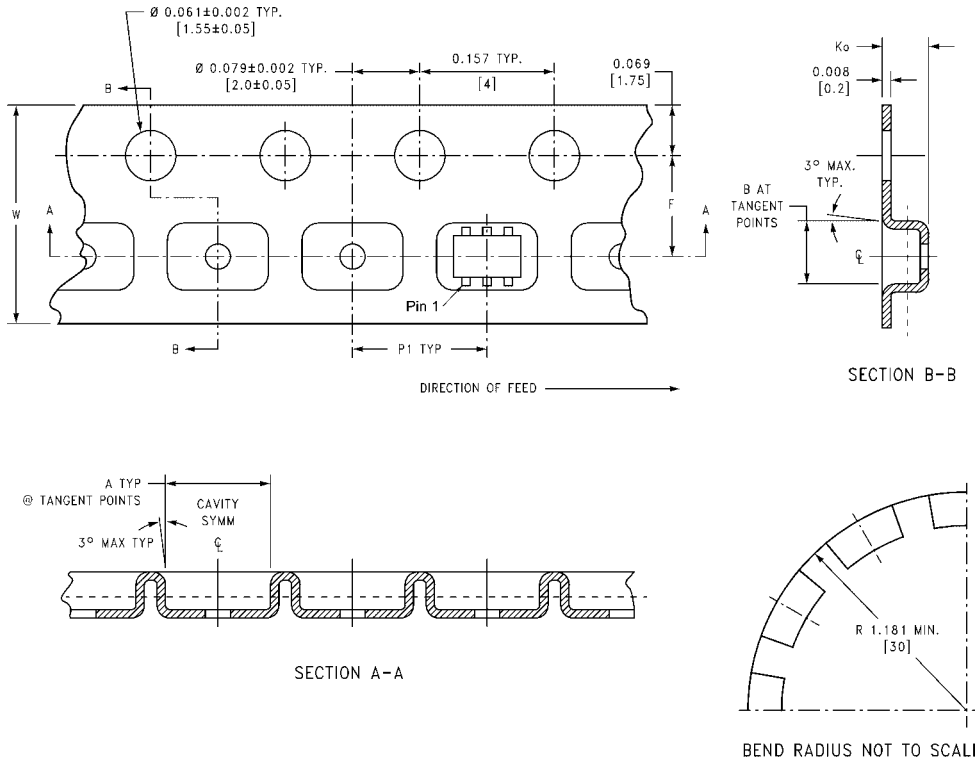

Package	Tape Size	DIM A	DIM B	DIM F	DIM K <sub>o</sub>	DIM P1	DIM W
SC70-6	8 mm	0.093 (2.35)	0.096 (2.45)	0.138 ± 0.004 (3.5 ± 0.10)	0.053 ± 0.004 (1.35 ± 0.10)	0.157 (4)	0.315 ± 0.004 (8 ± 0.1)

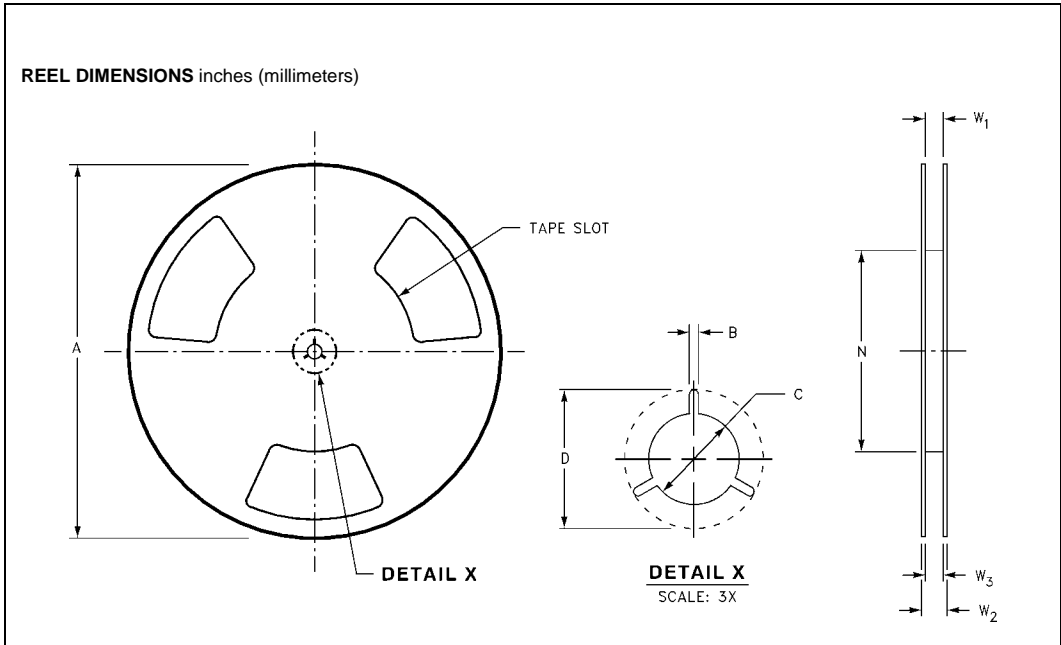

Tape Size	A	B	C	D	N	W1	W2	W3
8 mm	7.0 (177.8)	0.059 (1.50)	0.512 (13.00)	0.795 (20.20)	2.165 (55.00)	0.331 + 0.059/-0.000 (8.40 + 1.50/-0.00)	0.567 (14.40)	W1 + 0.078/-0.039 (W1 + 2.00/-1.00)

**Physical Dimensions** inches (millimeters) unless otherwise noted

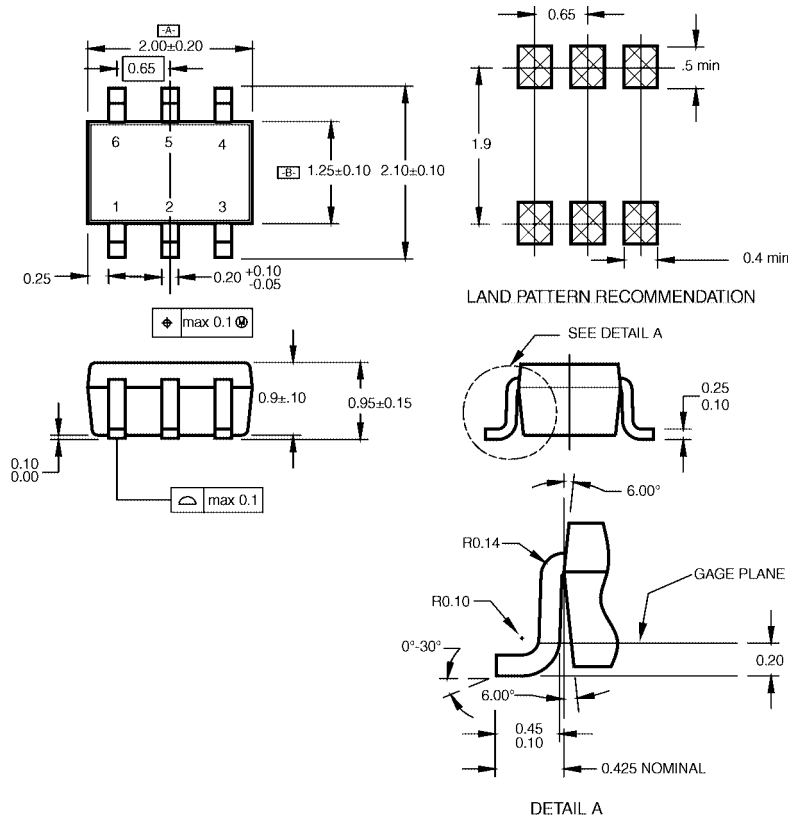

- NOTES:
- A. CONFORMS TO EIAJ REGISTERED OUTLINE DRAWING SC88.
  - B. DIMENSIONS DO NOT INCLUDE BURRS OR MOLD FLASH.
  - C. DIMENSIONS ARE IN MILLIMETERS.

**6-Lead SC70, EIAJ SC88, 1.25mm Wide  
Package Number MAA06A**

Fairchild does not assume any responsibility for use of any circuitry described, no circuit patent licenses are implied and Fairchild reserves the right at any time without notice to change said circuitry and specifications.

**LIFE SUPPORT POLICY**

FAIRCHILD'S PRODUCTS ARE NOT AUTHORIZED FOR USE AS CRITICAL COMPONENTS IN LIFE SUPPORT DEVICES OR SYSTEMS WITHOUT THE EXPRESS WRITTEN APPROVAL OF THE PRESIDENT OF FAIRCHILD SEMICONDUCTOR CORPORATION. As used herein:

1. Life support devices or systems are devices or systems which, (a) are intended for surgical implant into the body, or (b) support or sustain life, and (c) whose failure to perform when properly used in accordance with instructions for use provided in the labeling, can be reasonably expected to result in a significant injury to the user.
2. A critical component in any component of a life support device or system whose failure to perform can be reasonably expected to cause the failure of the life support device or system, or to affect its safety or effectiveness.

[www.fairchildsemi.com](http://www.fairchildsemi.com)