

FEATURES

- **VERY LOW NOISE FIGURE:**
0.6 dB typical at 12 GHz
- **HIGH ASSOCIATED GAIN:**
11 dB typical at 12 GHz
- **L_G = 0.25 μm, W_G = 200 μm**
- **LOW COST METAL/CERAMIC PACKAGE**
- **TAPE & REEL PACKAGING OPTION AVAILABLE**

DESCRIPTION

The NE32484A is a pseudomorphic Hetero-Junction FET that uses the junction between Si-doped AlGaAs and undoped InGaAs to create very high mobility electrons. The device features mushroom shaped TiAl gates for decreased gate resistance and improved power handling capabilities. The mushroom gate also results in lower noise figure and high associated gain. This device is housed in an epoxy-sealed, metal/ceramic package and is intended for high volume consumer and industrial applications.

NEC's stringent quality assurance and test procedures assure the highest reliability and performance.

**NOISE FIGURE & ASSOCIATED
GAIN vs. FREQUENCY**
V_{DS} = 2 V, I_{DS} = 10 mA

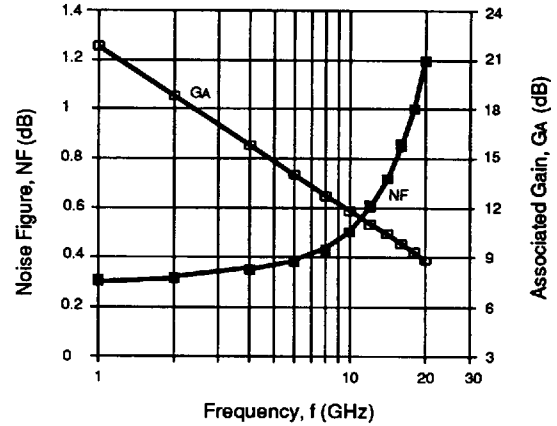

ELECTRICAL CHARACTERISTICS (T_A = 25°C)

PART NUMBER PACKAGE OUTLINE			NE32484A 84AS		
SYMBOLS	PARAMETERS AND CONDITIONS	UNITS	MIN	TYP	MAX
NF _{OPT} ¹	Noise Figure, V _{DS} = 2.0 V, I _D = 10 mA, f = 12 GHz	dB		0.6	0.7
GA ¹	Associated Gain, V _{DS} = 2.0 V, I _D = 10 mA, f = 12 GHz	dB	10.0	11.0	
P _{1dB}	Output Power at 1 dB Gain Compression Point, f = 12 GHz V _{DS} = 2.0 V, I _{DS} = 10 mA V _{DS} = 2.0 V, I _{DS} = 20 mA	dBm dBm		8.5 11.0	
G _{1dB}	Gain at P _{1dB} , f = 12 GHz V _{DS} = 2.0 V, I _{DS} = 10 mA V _{DS} = 2.0 V, I _{DS} = 20 mA	dB dB		10.0 10.5	
I _{DSS}	Saturated Drain Current, V _{DS} = 2.0 V, V _{GS} = 0 V	mA	15	40	70
V _P	Pinch-off Voltage, V _{DS} = 2.0 V, I _{DS} = 0.1 mA	V	-2.0	-0.8	-0.2
g _m	Transconductance, V _{DS} = 2.0 V, I _D = 10 mA	mS	45	60	
I _{GSO}	Gate to Source Leakage Current, V _{GS} = -3.0 V, I _D = 0 mA	μA		0.5	10.0
R _{TH} (CH-A)	Thermal Resistance (Channel to Ambient)	°C/W		750	
R _{TH} (CH-C)	Thermal Resistance (Channel to Case)	°C/W			350

Note:

1. Typical values of noise figures and associated gain are those obtained when 50% of the devices from a large number of lots were individually measured in a circuit with the input individually tuned to obtain the minimum value. Maximum values are criteria established on the production line as a "go-no-go" screening tuned for the "generic" type but not for each specimen.

ABSOLUTE MAXIMUM RATINGS¹ (T_A = 25°C)

SYMBOLS	PARAMETERS	UNITS	RATINGS
V _{DS}	Drain to Source Voltage	V	4.0
V _{GS}	Gate to Source Voltage	V	-3.0
I _{DS}	Drain Current	mA	I _{DSS}
I _{GRF}	Gate Current	μA	200
T _{CH}	Channel Temperature	°C	150
T _{STG}	Storage Temperature	°C	-65 to +150
PT	Total Power Dissipation	mW	165

Note:

1. Operation in excess of any of these parameters may result in permanent damage.

TYPICAL NOISE PARAMETERS (T_A = 25°C)

V_{DS} = 2 V, I_{DS} = 10 mA

FREQ. (GHz)	NF _{OPT} (dB)	GA (dB)	Γ _{OPT}		R _n /50
			MAG	ANG	
1	0.30	22.0	0.88	13	0.33
2	0.31	19.0	0.82	28	0.31
4	0.35	16.0	0.71	59	0.26
6	0.38	14.0	0.60	82	0.20
8	0.43	12.5	0.50	106	0.13
10	0.51	11.5	0.40	131	0.09
12	0.60	11.0	0.33	159	0.06
14	0.71	10.3	0.28	-166	0.05
16	0.85	9.8	0.28	-132	0.04
18	1.00	9.2	0.31	-104	0.04



TYPICAL PERFORMANCE CURVES (T_A = 25°C)

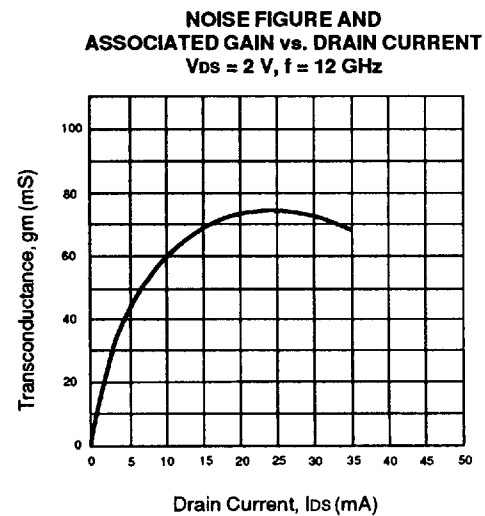
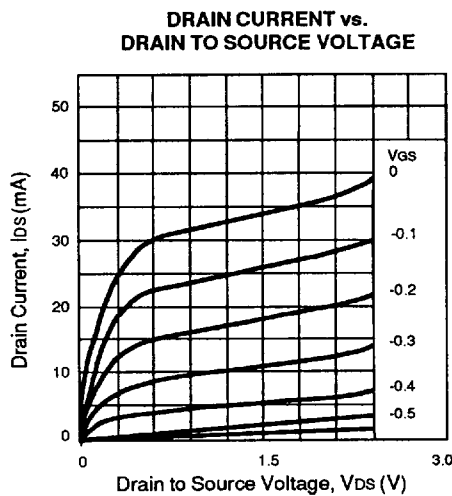
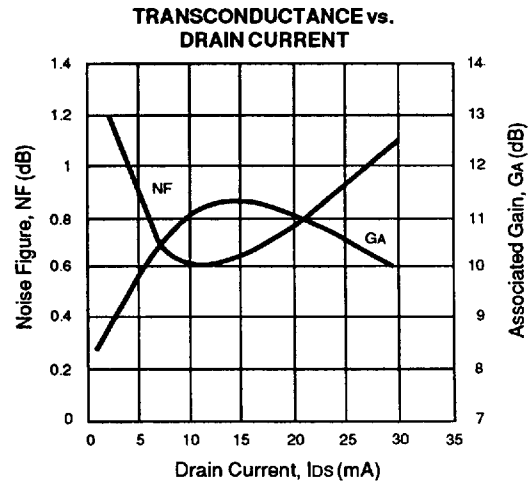
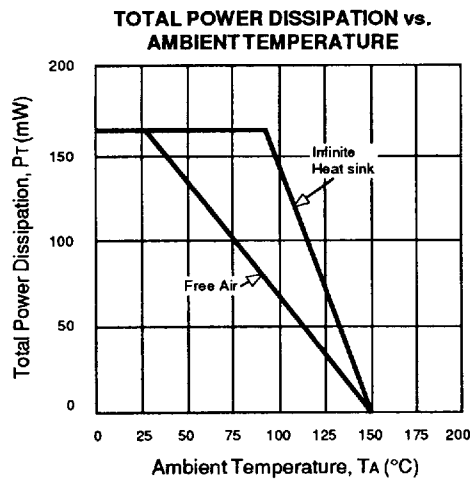

TYPICAL COMMON SOURCE SCATTERING PARAMETERS (TA = 25°C)

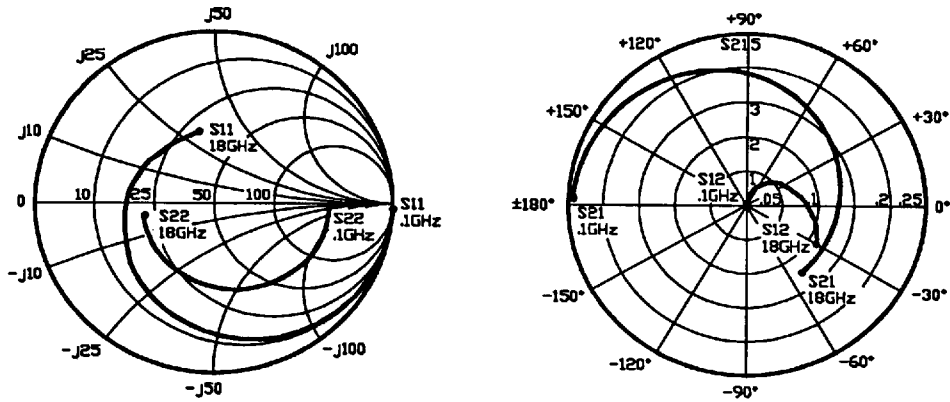

VDS = 2 V, IDS = 10 mA

FREQUENCY (GHz)	S11		S21		S12		S22		K	MAG ¹ (dB)
	MAG	ANG	MAG	ANG	MAG	ANG	MAG	ANG		
0.1	0.999	-2	4.89	178	0.002	89	0.647	-1	0.04	33.9
0.2	0.999	-4	4.89	176	0.003	87	0.646	-2	0.05	32.1
0.5	0.997	-9	4.87	171	0.009	83	0.645	-6	0.07	27.3
1.0	0.992	-18	4.81	162	0.018	77	0.641	-19	0.10	24.4
2.0	0.960	-35	4.65	146	0.033	67	0.632	-24	0.22	21.5
3.0	0.916	-51	4.45	130	0.046	58	0.614	-35	0.31	19.8
4.0	0.870	-66	4.23	115	0.059	49	0.590	-45	0.40	18.6
5.0	0.810	-80	4.01	101	0.069	41	0.568	-55	0.50	17.6
6.0	0.754	-94	3.78	87	0.077	34	0.550	-64	0.60	16.9
7.0	0.702	-108	3.54	74	0.082	27	0.531	-73	0.69	16.3
8.0	0.660	-120	3.31	62	0.087	22	0.513	-81	0.78	15.8
9.0	0.621	-131	3.14	51	0.090	18	0.498	-88	0.86	15.4
10.0	0.584	-142	3.03	40	0.096	14	0.485	-95	0.91	15.0
11.0	0.538	-155	2.94	29	0.102	10	0.472	-102	0.97	14.6
12.0	0.506	-168	2.83	17	0.107	5	0.458	-110	1.00	13.9
13.0	0.484	-177	2.76	6	0.112	-0	0.447	-119	1.01	13.2
14.0	0.463	-165	2.67	-5	0.118	-4	0.437	-127	1.02	12.6
15.0	0.445	-152	2.61	-16	0.124	-9	0.427	-136	1.03	12.2
16.0	0.420	-138	2.58	-27	0.133	-15	0.418	-145	1.02	12.0
17.0	0.415	-122	2.53	-39	0.140	-23	0.407	-157	1.00	12.4
18.0	0.425	-102	2.52	-51	0.149	-30	0.397	-169	0.94	12.3

Note:

1. Gain Calculations:

$$MAG = \frac{|S_{21}|}{|S_{12}|} (K \pm \sqrt{K^2 - 1})$$

When $K \leq 1$, MAG is undefined and MSG values are used. $MSG = \frac{|S_{21}|}{|S_{12}|}$, $K = \frac{1 + |\Delta|^2 - |S_{11}|^2 - |S_{22}|^2}{2 |S_{12} S_{21}|}$, $\Delta = S_{11} S_{22} - S_{21} S_{12}$

MAG = Maximum Available Gain

MSG = Maximum Stable Gain

TYPICAL COMMON SOURCE SCATTERING PARAMETERS (TA = 25°C)

VDS = 2 V, IDS = 20 mA

FREQUENCY (GHz)	S11		S21		S12		S22		K	MAG ¹ (dB)
	MAG	ANG	MAG	ANG	MAG	ANG	MAG	ANG		
0.1	1.000	-3	5.59	177	0.002	89	0.560	-3	0.01	34.5
0.2	0.999	-4	5.57	176	0.003	87	0.559	-4	0.04	32.7
0.5	0.997	-10	5.55	170	0.008	83	0.555	-7	0.07	28.4
1.0	0.986	-19	5.47	161	0.016	79	0.550	-13	0.14	25.3
2.0	0.950	-36	5.26	144	0.030	69	0.538	-24	0.27	22.4
3.0	0.903	-52	5.01	128	0.043	61	0.526	-34	0.37	20.7
4.0	0.848	-67	4.70	113	0.054	53	0.515	-44	0.48	19.4
5.0	0.786	-82	4.41	99	0.064	46	0.503	-53	0.58	18.4
6.0	0.727	-96	4.12	85	0.073	39	0.492	-62	0.67	17.5
7.0	0.676	-110	3.85	72	0.079	33	0.480	-71	0.75	16.9
8.0	0.628	-122	3.59	61	0.086	29	0.468	-78	0.83	16.2
9.0	0.587	-133	3.37	49	0.090	24	0.457	-85	0.91	15.7
10.0	0.551	-144	3.24	38	0.099	20	0.445	-91	0.94	15.1
11.0	0.514	-156	3.11	27	0.108	16	0.434	-97	0.96	14.6
12.0	0.477	-170	3.00	16	0.115	10	0.422	-105	0.99	14.2
13.0	0.456	176	2.91	5	0.121	4	0.410	-114	1.00	13.8
14.0	0.437	164	2.82	-5	0.129	-1	0.399	-122	1.00	13.4
15.0	0.420	151	2.75	-17	0.136	-8	0.387	-131	1.01	12.6
16.0	0.392	136	2.70	-28	0.147	-14	0.376	-141	1.00	12.6
17.0	0.393	120	2.65	-40	0.154	-23	0.364	-152	0.98	12.4
18.0	0.404	101	2.63	-51	0.163	-31	0.352	-164	0.94	12.1

Note:

1. Gain Calculations:

$$MAG = \frac{|S_{21}|}{|S_{12}|} (K \pm \sqrt{K^2 - 1})$$

. When $K \leq 1$, MAG is undefined and MSG values are used. $MSG = \frac{|S_{21}|}{|S_{12}|}$, $K = \frac{1 + |\Delta|^2 - |S_{11}|^2 - |S_{22}|^2}{2 |S_{12} S_{21}|}$, $\Delta = S_{11} S_{22} - S_{21} S_{12}$

MAG = Maximum Available Gain

MSG = Maximum Stable Gain

OUTLINE DIMENSIONS (TA = 25°C)

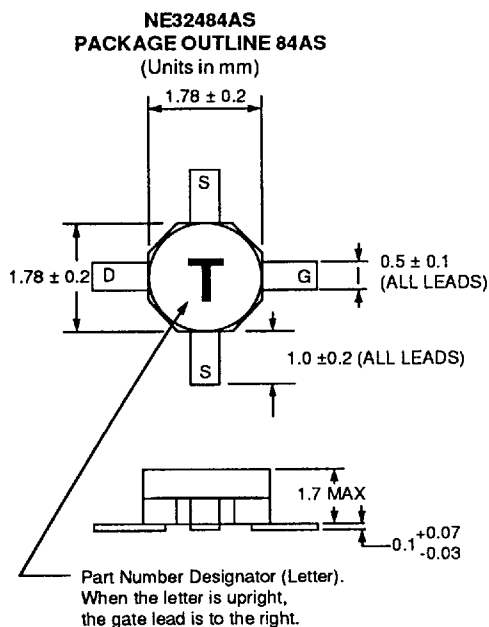

ORDERING INFORMATION

PART NUMBER	QTY	PACKAGE
NE32484AS	Bulk up to 1 K	84AS
NE32484A-T1	1K/Reel	84AS

Note:

Long leaded (1.7 min.) 84A package available upon request in bulk quantities up to 1000 pcs. To order specify NE32484A-SL.