

NEC

PRELIMINARY DATA SHEET

3W, L/S-BAND MEDIUM POWER GaAs MESFET

NE6500379A

FEATURES

- LOW COST PLASTIC SURFACE MOUNT PACKAGE
- HIGH OUTPUT POWER: +35 dBm TYP
- HIGH LINEAR GAIN: 10 dB TYP
- HIGH POWER ADDED EFFICIENCY: 50% TYP @
V_{DS} = 6 V, I_{DSQ} = 500 mA, f = 1.9 GHz
- CLASS AB OPERATION
- TAPE & REEL PACKAGE OPTION AVAILABLE

DESCRIPTION

The NE6500379A is a 3 W GaAs MESFET designed for medium power transmitter applications for mobile communication handset and base station systems. It is capable of delivering 3 watts of output power (CW) with high linear gain, high efficiency, and excellent distortion. Reliability and performance uniformity are assured by NEC's stringent quality and control procedures.

OUTLINE DIMENSIONS (Units in mm)

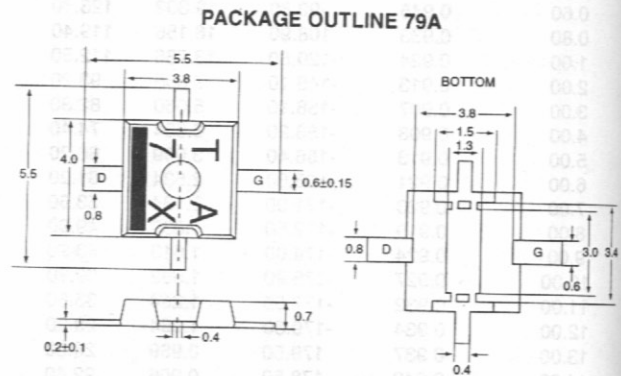

Note: Unless otherwise specified, tolerance is ± 0.2 mm.

ELECTRICAL CHARACTERISTICS (T_c = 25°C)

		PART NUMBER		NE6500379A				
		PACKAGE OUTLINE		79A				
		SYMBOLS	CHARACTERISTICS	UNITS	MIN	TYP	MAX	TEST CONDITIONS
Functional Characteristics	P _{1dB}		Power Out at 1dB Gain Compression	dBm		35.0		f = 1.9 GHz, V _{DS} = 6.0 V, R _g = 30 Ω I _{DSQ} = 500 mA (RF OFF) (Note 2)
	GL		Linear Gain ¹	dB	9.0	10.0		
	η _{ADD}		Power Added Efficiency	%		50		
	I _D		Drain Current	A		0.85		
Electrical DC Characteristics	I _{DSS}		Saturated Drain Current	A		4.5		V _{DS} = 2.5 V; V _{GS} = 0 V
	V _P		Pinch-Off Voltage	V	-3.6		-1.6	V _{DS} = 2.5 V; I _{DS} = 21 mA
	R _{TH}		Thermal Resistance	°C/W		5	6	Channel to Case
	BVGD		Gate-to-Drain Breakdown Voltage	V	17			I _{GD} = 21 mA

Notes:

1. Pin = 0 dBm
2. DC performance is tested 100%. Several samples per wafer are tested for RF performance. Wafer rejection criteria for standard devices is 1 reject for several samples.