



ALUMINUM ELECTROLYTIC
CAPACITORS

NIPPON CHEMI-CON

QS 9000/ISO 9001 REGISTERED

Series		Features	Endurance (+R=With ripple)	Standard type	Low impedance	Solvent-proof	Terminal type	Rated voltage range (V _{dc})	Capacitance range (μF)	
Surface Mount	Low ESR	PX	Functional-polymer, super low ESR	105°C 2,000 hours		●	SMD	4 to 25	6.8 to 680	
		MX <small>(NEW!)</small>	Solid aluminum, high heat resistance	125°C 2,000 hours +R		●	SMD	4 to 16	6.8 to 56	
		MFZ	Solid aluminum, low ESR, high cap.	85/105°C 1,000 hours +R		●	SMD	4 to 20	3.3 to 56	
		MFX	Solid aluminum, low ESR	85/105°C 1,000 hours +R		●	SMD	4 to 16	4.7 to 47	
	General purpose	MFS/MFA	3.5 to 4.5mm height, downsized	85°C 1,000 to 2,000hours			●	SMD	4 to 35	0.1 to 100
		MF	3.2 to 4.7mm max. height	85°C 2,000 hours	●		●	SMD	4 to 50	0.1 to 150
		MFK	3.7 to 4.7mm max. height	105°C 1,000 hours	●		●	SMD	6.3 to 50	0.1 to 100
		MFY	4.7mm max. height	105°C 1,000 hours		●	●	SMD	6.3 to 50	3.3 to 100
		MFJ	4.7mm max. height	105°C 2,000 hours	●		●	SMD	6.3 to 50	3.3 to 100
		MFK-Large	9.2mm max. height	105°C 2,000 hours	●		●	SMD	10 to 50	47 to 1,000
		MVS	4.5mm height	85°C 2,000 hours	●		●	SMD	4 to 50	0.1 to 220
		MVA <small>(Upgrade!)</small>	5.5 to 22.0mm max. height, downsized	85°C 2,000 hours			▲	SMD	4 to 450	0.1 to 10,000
		MV	5.5 to 10.5mm max. height	85°C 1,000 to 2,000 hours	●		●	SMD	4 to 63	0.1 to 1,000
		MVE <small>(NEW!)</small>	5.5 to 22.0mm max. height, downsized	105°C 1,000 to 2,000 hours			▲	SMD	6.3 to 450	0.47 to 6,800
		MVK	5.5 to 10.5mm max. height	105°C 1,000 to 2,000 hours	●		●	SMD	6.3 to 50	0.1 to 1,000
		MVY <small>(Upgrade!)</small>	5.5 to 22.0mm max. height	105°C 1,000 to 5,000 hours		●	●	SMD	6.3 to 100	1.0 to 8,200
		MVJ	6.0mm max. height	105°C 2,000 hours	●		●	SMD	6.3 to 50	0.1 to 100
		MVL <small>(Upgrade!)</small>	6.0mm max. height	105°C 3,000 to 5,000 hours			●	SMD	6.3 to 50	0.1 to 100
	MVH <small>(Upgrade!)</small>	6.0 to 22.0mm max. height	125°C 1,000 to 5,000 hours			▲	SMD	10 to 450	3.3 to 4,700	
	Bi-Polar	MF-BP	3.7 to 4.7mm max. height, bi-polar	85°C 2,000 hours			●	SMD	4 to 50	0.1 to 22
MFK-BP		3.7 to 4.7mm max. height, bi-polar	105°C 1,000 hours			●	SMD	6.3 to 50	0.1 to 10	
MV-BP		5.5mm max. height, bi-polar	85°C 2,000 hours			●	SMD	4 to 50	0.1 to 47	
MVK-BP		6.0mm max. height, bi-polar	105°C 1,000 hours			●	SMD	6.3 to 50	0.1 to 47	
Miniature	Low Profile	SRM	5mm height, downsized	85°C 1,000 hours		●	Radial	4 to 50	0.1 to 330	
		SRE	5mm height	85°C 1,000 hours	●		Radial	4 to 50	0.1 to 100	
		KRE	5mm height	105°C 1,000 hours	●		●	Radial	6.3 to 50	0.1 to 100
		SRA	7mm height	85°C 1,000 hours	●			Radial	4 to 63	0.1 to 470
		KMA	7mm height	105°C 1,000 hours	●		●	Radial	4 to 63	0.1 to 220
		SRG	φ4×7 to φ18×25mm, low profile	85°C 1,000 to 2,000 hours			●	Radial	4 to 50	0.1 to 10,000
		KRG	φ4×7 to φ18×25mm, low profile	105°C 1,000 hours			●	Radial	6.3 to 50	0.1 to 10,000
	General Purpose	SMG	General, downsized	85°C 2,000 hours	●		▲	Radial	6.3 to 450	0.1 to 39,000
		KMG	General, downsized	105°C 1,000 to 2,000 hours +R	●		▲	Radial	6.3 to 450	0.1 to 22,000
		SME	General	85°C 2,000 hours	●		▲	Radial	6.3 to 450	0.1 to 15,000
		KME	General	105°C 1,000 hours +R	●		▲	Radial	6.3 to 400	0.1 to 15,000
		KMY	Long life, general	105°C 4,000 to 7,000 hours	●	●		Radial	10 to 50	0.47 to 10,000
	Bi-Polar, General	SME-BP	Bi-polar, general	85°C 2,000 hours	●		●	Radial	6.3 to 100	0.47 to 6,800
		KME-BP	Bi-polar, general	105°C 1,000 hours	●		●	Radial	6.3 to 100	0.47 to 6,800
	High Frequency Use	LXZ	Lowest impedance, downsized	105°C 2,000 to 8,000 hours +R		●	●	Radial	6.3 to 63	12 to 18,000
		LXY	Low impedance, high reliability	105°C 2,000 to 8,000 hours +R	●	●	●	Radial	10 to 63	10 to 8,200
		LXV	Low impedance, general	105°C 2,000 to 5,000 hours +R	●	●	●	Radial	6.3 to 100	5.6 to 15,000
		SXE	Low impedance, general	105°C 1,000 to 2,000 hours		●	●	Radial	6.3 to 100	1.5 to 15,000
		LXJ	Low impedance, general	105°C 2,000 to 5,000 hours +R	●	●	●	Radial	6.3 to 50	0.47 to 15,000
		KZE <small>(NEW!)</small>	Lowest impedance, long life	105°C 2,000 to 5,000 hours +R		●		Radial	6.3 to 50	22 to 6,800
KY <small>(NEW!)</small>		Low impedance, long life	105°C 3,000 to 6,000 hours +R		●		Radial	6.3 to 50	22 to 18,000	
KMF		Low impedance, high CV, general	105°C 2,000 to 5,000 hours +R	●	●	▲	Radial	6.3 to 450	0.47 to 15,000	
High Reliability	KMX	Long life, for input filtering	105°C 8,000 to 10,000 hours +R		●		Radial	160 to 450	3.3 to 680	
	SMH	φ20×20 to φ22×50mm	85°C 2,000 hours +R	●			Radial	160 to 450	33 to 470	
	KMH	φ20×20 to φ22×50mm	105°C 2,000 hours +R	●			Radial	160 to 450	33 to 470	

● : Promotional products

▲ : Some of range are solvent-proof.

Series		Features	Endurance (+R=With ripple)	Standard type	Low impedance	Solvent-proof	Terminal type	Rated voltage range (V _{dc})	Capacitance range (μF)	
Miniature	High Reliability	PA	Low profile, for input filtering	105°C 2,000 hours +R			Radial	200 & 400	10 to 150	
		KLG	No sparks with DC overvoltage	105°C 2,000 hours +R			Radial	200 & 400	22 to 220	
		FL <small>(NEW!)</small>	Long life	105°C 3,000 to 6,000 hours +R			●	Radial	6.3 to 50	0.47 to 1,500
		LXA	Long life	105°C 5,000 to 7,000 hours			●	Radial	10 to 63	0.47 to 4,700
		LX	Long life	105°C 5,000 hours			●	Radial	100 to 250	0.47 to 68
		EX	105°C and 125°C lifetime specified	105°C 2,000 to 5,000 hours +R			●	Radial	10 to 63	0.1 to 10,000
		GXE <small>(Upgrade!)</small>	125°C, downsize, low impedance	125°C 2,000 to 5,000 hours +R				Radial	10 to 450	4.7 to 4,700
		GXD	125°C	125°C 1,000 to 2,000 hours				Radial	10 to 63	0.47 to 1,000
	Special Application	LBG	For airbag	105°C 5,000 hours +R		●	●	Radial	16 to 35	820 to 6,800
		LLA	Low DC leakage, general	85°C 1,000 hours			●	Radial	6.3 to 50	0.1 to 15,000
		PH	For photo flash	55°C 5,000 times charging				Radial	300 & 330	50 to 240
Large Sized	General Purpose	SMQ <small>(NEW!)</small>	Snap-in terminal, more downsized	85°C 2,000 hours +R	●		Pin	160 to 450	82 to 3,900	
		KMQ <small>(NEW!)</small>	Snap-in terminal, more downsized	105°C 2,000 hours +R	●		Pin	160 to 450	68 to 3,300	
		SMM	Snap-in terminal, downsized	85°C 3,000 hours +R	●			Pin	160 to 450	47 to 3,300
		KMM	Snap-in terminal, downsized	105°C 2,000 to 3,000 hours +R	●			Pin	160 to 450	39 to 3,300
		SMH	Snap-in terminal, general	85°C 2,000 hours +R	●			Pin	6.3 to 450	56 to 100,000
		KMH	Snap-in terminal, general	105°C 2,000 hours +R	●			Pin	6.3 to 450	47 to 82,000
	Low Profile	SLM	15mm height	85°C 2,000 hours +R				Pin	160 to 400	47 to 560
		KLM	15mm height	105°C 2,000 hours +R				Pin	160 to 400	39 to 390
	High Reliability	LXM <small>(NEW!)</small>	Long life	105°C 7,000 hours +R				Pin	160 to 450	47 to 2,200
		LXG	Long life	105°C 5,000 hours +R				Pin	10 to 450	39 to 47,000
		LXH	No sparks with DC overvoltage	105°C 3,000/5,000 hours +R				Pin	200 & 400	68 to 1,500
		KLG	No sparks with DC overvoltage	105°C 2,000 hours +R				Pin	200 & 400	33 to 1,500
		KSL	Mechanically open mode cap	105°C 2,000 hours +R				Pin	200 & 400	180 to 1,500
		RWE-LR	For air-conditioning	85°C 3,000 hours +R				Lug	250 to 450	330 to 2,200
	Screw-mount Terminal Type	General Purpose	SME	Screw terminal, general	85°C 2,000 hours +R	●		Screw	10 to 250	560 to 680,000
			KMH	Screw terminal, general	105°C 2,000 hours +R	●		Screw	10 to 400	180 to 680,000
For Inverter		RWE	High ripple	85°C 2,000 hours +R	●			Screw	350 to 550	100 to 12,000
		RWY	High ripple, long life, low cost	85°C 5,000 hours +R				Screw	350 to 450	500 to 14,000
		RWF	High ripple, long life	85°C 5,000 hours +R				Screw	350 to 450	1,200 to 22,000
		RWL	High ripple, long life	85°C 20,000 hours +R				Screw	350 to 450	2,200 to 12,000
		LXA <small>(Upgrade!)</small>	Long life	105°C 2,000/5,000 hours +R				Screw	10 to 525	330 to 390,000
		LX	Long life	105°C 5,000 hours +R				Screw	350 to 450	2,200 to 12,000
		LXR	High ripple, long life	105°C 5,000 hours +R				Screw	350 to 450	2,200 to 15,000
Low Impedance		KW	Low impedance	105°C 2,000 hours		●		Screw	10 to 100	1,000 to 100,000

: Promotional products

◆SURFACE MOUNT

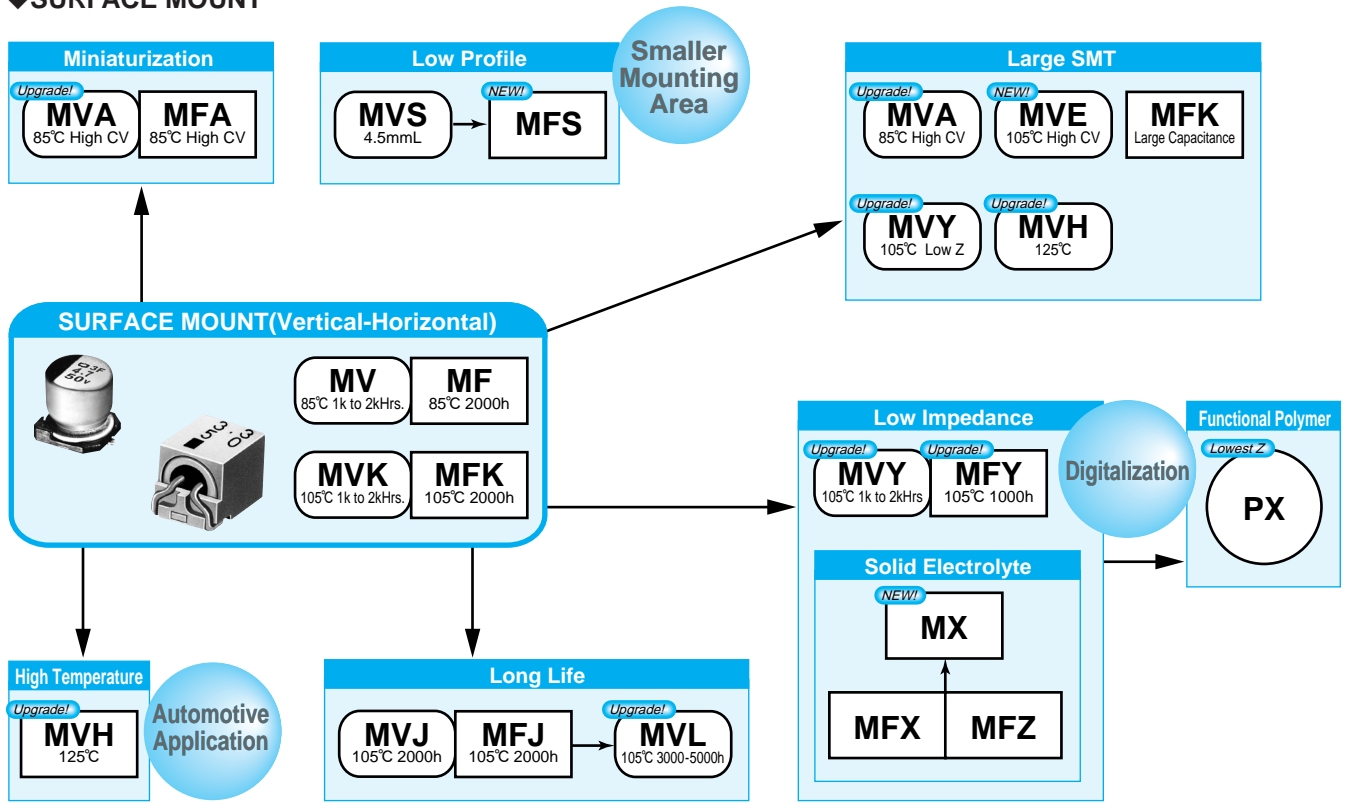

◆RADIAL LEAD

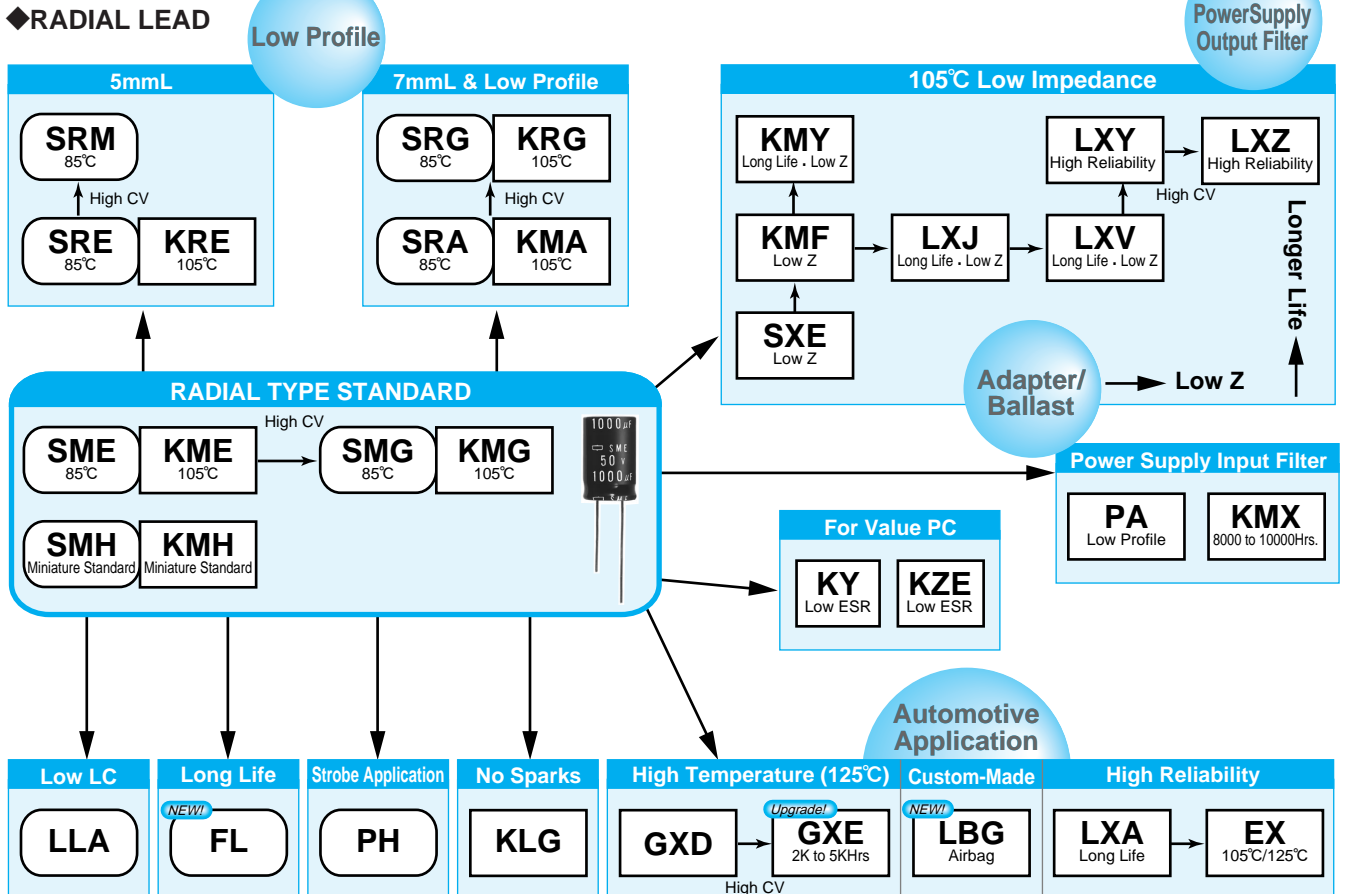

◆SNAP-IN

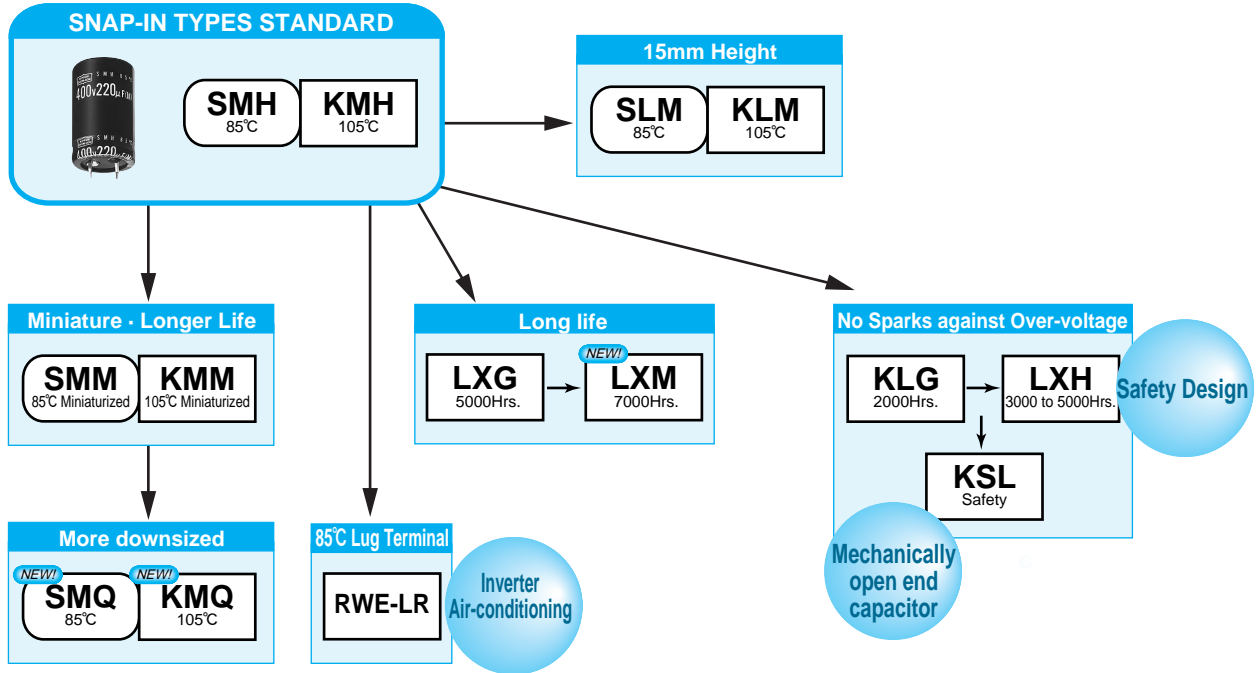

◆SCREW-MOUNT TERMINAL

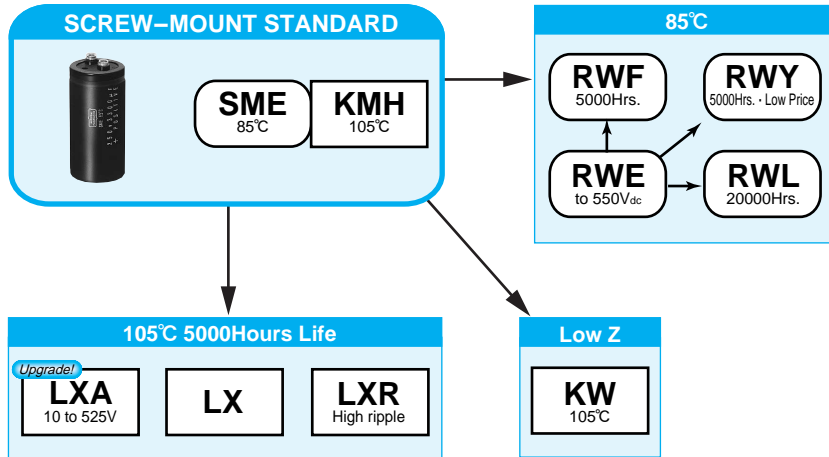

The following series are discontinued. Please use the recommended replacements in the table.

◆ LEAD TYPE REPLACEMENTS



Discontinued series	Characteristics	Replacements
SL	85°C standard	SME
SM		
SMC		
KM	105°C standard	KME
KMC		
SM-BP		
KM-BP	85°C bi-polarized	SME-BP
SR	105°C bi-polarized	KME-BP
SRC	85°C low profile	SRG
SRJ		
SX		
SXA	Low impedance	LXJ
SXC		
RX		
RXC		
LXE		
SXF		
LXF	Low impedance Long life	LXY
TXF		
LX (10 to 63V _{dc})	Long life	LXA & EX
KX	High heat resistance	GXD & GXE
KXC		
GX		
EU	High temperature performance	LXY
LL	Low leakage current	LLA
LR		
KHA	High ripple current	KMF & KMX
KXB		
BX	JIS B X-characteristics	KMG
SM (VP-type)	85°C large radial	SMG
SRF		
KRF		
GX-VH	High operating temperature	*
SD	2 volt	
KRL	105°C low leakage current	
KSA	Bi-polarized high ripple	

◆ SNAP-IN REPLACEMENTS



Discontinued series	Characteristics	Replacements
SM	85°C standard	SMH & SMM
SME		
SMG		
KM	105°C standard	KMH & KMM
KME		
KMG		
NM	Long case size	SMH
NMA		
BK	Long height	KMH, KMM
NM-HR	High ripple current	
BX	JIS B X-characteristics	
LX	Long life	LXG
LXA		
RZ	Low impedance	*

◆ SCREW-MOUNT TERMINAL REPLACEMENTS



Discontinued series	Characteristics	Replacements
EW	85°C standard	SME
PW		
MW		
GW	100°C	KMH
SW	For inverter	RWE & RWF
RW		
RWA	High reliability	KMH
KM		
KME		
FW	Low impedance	KW

*Please consult us GX-VH, SD, KRL, KSA, and RZ series.

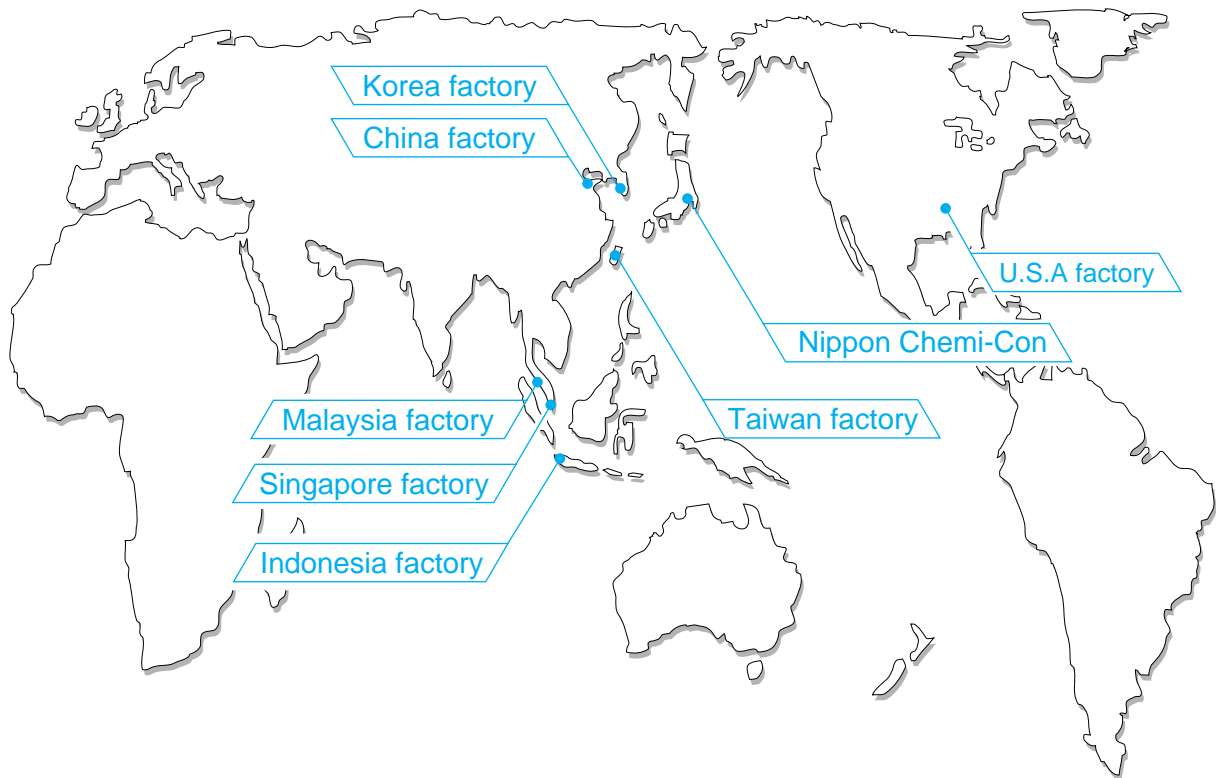

◆AVAILABLE ITEMS BY MANUFACTURING LOCATIONS

Classification	Series	Korea factory	China factory	Singapore factory	Indonesia factory	Taiwan factory	Malaysia factory	U.S.A. factory
Low profile	SRE			●				
	SRA	●	●	●	●	●	●	
	KMA	●		●	●	●	●	
	SRG	●		●	●		●	
General purpose	SMG	●	●	●	●	●	●	
	KMG	●	●	●	●	●	●	
	SME	●	●	●	●	●	●	
	KME	●	●	●	●	●	●	
Bi-polar	SME-BP	●		●	●	●	●	
	KME-BP	●		●		●	●	
Low impedance	LXV			●				
	LXJ			●		●		
	SXE					●		
Snap-in	SMH						●	●
	KMH						●	●
	KMM						●	●
Screw-mount Terminal	KMH							●
	RWE							●
	RWF							●
	RWL							●
	LXA							●
	LX							●

Designing Device Circuits

1 Select the capacitors to suit installation and operating conditions, and use the capacitors to meet the performance limits prescribed in this catalog or the product specifications.

2 Polarity

Aluminum Electrolytic Capacitors are polarized. Apply neither reverse voltage nor AC voltage to polarized capacitors. Using reversed polarity causes a short circuit or venting. Before use, refer to the catalog, product specifications or capacitor body to identify the polarity marking. Use a bi-polar type of non-solid aluminum electrolytic capacitor for a circuit where the polarity is occasionally reversed. However, note that even a bi-polar aluminum electrolytic capacitor must not be used for AC voltage applications. (Solid electrolyte capacitors of MFX and MFZ series can withstand a maximum reverse voltage of 15% of the rated voltage for 250 hours at 85°C. MX series can do 15% of the rated voltage for 250 hours at 125°C.)

3 Operating voltage

Do not apply a DC voltage which exceeds the full rated voltage. The peak voltage of a superimposed AC voltage (ripple current) on the DC voltage must not exceed the full rated voltage. A surge voltage value, which exceeds the full rated voltage, is prescribed in the catalogs, but it is a restricted condition, for especially short periods of time. Also, when using MFX or MFZ series solid aluminum electrolytic capacitors at temperatures of more than 85°C, apply a low voltage in accordance with the catalogs or the product specifications.

4 Ripple current

The use of a capacitor outside the rated operating temperature will considerably shorten the life or cause the capacitor to vent. The maximum permissible ripple current has been specified at a certain ripple frequency. The rated ripple current at several frequencies must be calculated by multiplying the rated ripple current at the original frequency using the frequency multipliers for each product series. For more details, refer to the paragraph of Life of Aluminum Electrolytic Capacitors.

5 Category temperature

The use of a capacitor outside the maximum rated category temperature will considerably shorten the life or cause the capacitor to vent. The relation between the lifetime of aluminum electrolytic capacitors and ambient temperature follows Arrhenius' rule that the lifetime is approximately halved with each 10°C rise in ambient temperature.

6 Life expectancy

Select the capacitors to meet the service life of a device.

7 Charge and discharge

Do not use capacitors in circuits where heavy charge and discharge cycles are frequently repeated. Frequent and sharp heavy discharging cycles will result in decreasing capacitance and damage to the capacitors due to generated heat. Specified capacitors can be designed to meet the requirements of charging-discharging cycles, frequency, operating temperature, etc.

8 Failure mode of capacitors

a) Non-solid aluminum electrolytic capacitors, in general, have a lifetime which ends in an open circuit, the period is dependent upon temperature. Consequently, lifetime of capacitors can be extended by reducing the ambient temperature and/

or ripple current.

b) Solid aluminum electrolytic capacitors, MX, MFX and MFZ series, in general, have a random failure period in that the lifetime ends with a short circuit. Take account of this failure mode in designing devices. Decreasing operating voltage, ambient temperature, and inrush current can reduce the failure rate.

9 Insulating

a) Electrically isolate the following parts of a capacitor from the negative terminal, the positive terminal and the circuit traces.

- The outer can case of a non-solid aluminum capacitor.
- The dummy terminal of a non-solid aluminum capacitor, which is designed for mounting stability.
- The dummy terminal of a surface mount type capacitor such as non-solid type MF/MFK/MFY/MFJ series capacitors or solid type MX, MFX, and MFZ series capacitors.

b) The outer sleeve of a capacitor is not assured as an insulator. For applications that require an insulated outer sleeve, a custom-design capacitor is recommended to.

10 Condition

Do not use/expose capacitors to the following conditions.

a) Oil, water, salty water take care to avoid storage in damp locations.

b) Toxic gases such as hydrogen sulfide, sulfurous acid, nitrous acid, chlorine or its compounds, and ammonium

c) Ozone, ultraviolet rays or radiation

d) Severe vibration or mechanical shock conditions beyond the limits prescribed in the catalogs or the product specification.

11 Mounting

a) The paper separators and the electrolytic-conductive electrolytes in a non-solid aluminum electrolytic capacitor are flammable.

Leaking electrolyte on a printed circuit board can gradually erode the copper traces, possibly causing smoke or burning by short-circuiting the copper traces.

Verify the following points when designing a PC board.

- Provide the appropriate hole spacing on the PC board to match the terminal spacing of the capacitor.
- Make the following open space over the vent so that the vent can operate correctly

Case diameter	Clearance
φ6.3 to φ16mm	2mm minimum
φ18 to φ35mm	3mm minimum
φ40mm and up	5mm minimum

- Do not place any wires or copper traces over the vent of the capacitor.
- Installing a capacitor with the vent facing the PC board needs an appropriate ventilation hole in PC board.
- Do not pass any copper traces beneath the seal side of a capacitor. The trace must pass 1 or 2mm to the side of the capacitor.
- Avoid placing any heat-generating objects adjacent to a capacitor or even on the reverse side of the PC board.
- Do not pass any via holes or underneath a capacitor.
- In designing double-sided PC boards, do not locate any copper trace under the seal side of a capacitor.

b) Do not mount the terminal side of a screw mount capacitor downwards. If a screw terminal capacitor is mounted on its side, make sure the positive terminal is higher than the negative terminal.

Do not fasten the screws of the terminals and the mounting clamps over the specified torque prescribed in the catalog or the production specification.

c) For a surface mount capacitor, design the copper pads of the PC board in accordance with the catalog or the product specifications.

12 Others

- a) The electrical characteristics of capacitors vary in respect to temperature, frequency and service life. Design the device circuits by taking these changes into account.
- b) Capacitors mounted in parallel need the current to flow equally through the individual capacitors.
- c) Capacitors mounted in series require resistors in parallel with the individual capacitors to balance the voltage.

Installing Capacitors

1 Installing

- a) Used capacitors are not reusable, except in the case that the capacitors are detached from a device for periodic inspection to measure their electrical characteristics.
- b) If the capacitors have self charged, discharge in the capacitors through a resistor of approximately 1k Ω before use.
- c) If capacitors are stored at a temperature of 35 $^{\circ}$ C or more and more than 75%RH, the leakage current may increase. In this case, they can be reformed by applying the rated voltage through a resistor of approximately 1k Ω .
- d) Verify the rated capacitance and voltages of the capacitors when installing.
- f) Verify the polarity of the capacitors.
- g) Do not use the capacitors if they have been dropped on the floor.
- h) Do not deform the cases of capacitors.
- g) Verify that the lead spacing of the capacitor fits the hole spacing in the PC board before installing the capacitors. Some standard pre-formed leads are available.
- h) For pin terminals or snap-in terminals, insert the terminals into PC board and press the capacitor downward until the bottom of the capacitor body reaches PC board surface.
- i) Do not apply any mechanical force in excess of the limits prescribed in the catalogs or the product specifications of the capacitors.
Also, note the capacitors may be damaged by mechanical shocks caused by the vacuum/insertion head, component checker or centering operation of an automatic mounting or insertion machine.

2 Soldering and Solderability

- a) When soldering with a soldering iron
 - Soldering conditions (temperature and time) should be within the limits prescribed in the catalogs or the product specifications.
 - If the terminal spacing of a capacitor does not fit the terminal hole spacing of the PC board, reform the terminals in a manner to minimize a mechanical stress into the body of the capacitor.
 - Remove the capacitors from the PC board, after the solder is completely melted, reworking by using a soldering iron minimizes the mechanical stress to the capacitors.
 - Do not touch the capacitor body with the hot tip of the soldering iron.
- b) Flow soldering
 - Do not dip the body of a capacitor into the solder bath only dip the terminals in. The soldering must be done on the reverse side of PC board.
 - Soldering conditions (preheat, solder temperature and dipping time) should be within the limits prescribed in the catalogs or the product specifications.
 - Do not apply flux to any part of capacitors other than their terminals.
 - Make sure the capacitors do not come into contact with any other components while soldering
- c) Reflow soldering
 - Soldering conditions (preheat, solder temperature and dipping time) should be within the limits prescribed in the cata-

logs or the product specifications.

- When setting the temperature infrared heaters, consider that the infrared absorption causes material to be discolored and change in appearance.
 - Do not solder capacitors more than once using reflow. If you need to twice, be sure to consult us.
 - Make sure capacitors do not come into contact with copper traces.
- d) Do not re-use surface mount capacitors which have already been soldered.
In addition, when installing a new capacitor onto the assembly board to rework, remove old residual flux from the surface of the PC board, and then use a soldering iron within the prescribed conditions.

3 Handling after soldering

Do not apply any mechanical stress to the capacitor after soldering onto the PC board.

- a) Do not lean or twist the body of the capacitor after soldering the capacitors onto the PC board.
- b) Do not use the capacitors for lifting or carrying the assembly board.
- c) Do not hit or poke the capacitor after soldering to PC board. When stacking the assembly board, be careful that other components do not touch the aluminum electrolytic capacitors.
- d) Do not drop the assembly board.

4 Cleaning PC board

- a) Do not wash capacitors by using the following cleaning agents. Solvent-proof capacitors are only suitable for washing using the cleaning conditions prescribed in the catalogs or the product specifications. In particular, ultrasonic cleaning will accelerate damaging capacitors.
 - Halogenated solvents; cause capacitors to fail due to corrosion.
 - Alkali system solvents; corrode (dissolve) an aluminum case.
 - Petroleum system solvents; cause the rubber seal material to deteriorate.
 - Xylene; causes the rubber seal material to deteriorate.
 - Acetone; erases the marking.
- b) Verify the following points when washing capacitors.
 - Monitor conductivity, pH, specific gravity, and the water content of cleaning agents. Contamination adversely affects these characteristics.
 - Be sure not to expose the capacitors under solvent rich conditions or keep capacitors inside a closed container. In addition, please dry the solvent sufficiently on the PC board and the capacitor with an air knife (temperature should be less than the maximum operating temperature of the capacitor) over 10 minutes.
Aluminum electrolytic capacitors can be characteristically and catastrophically damaged by halogen ions, particularly by chlorine ions, though the degree of the damage mainly depends upon the characteristics of the electrolyte and rubber seal material. When halogen ions come into contact with the capacitors, the foil corrodes when voltages applied. This corrosion causes ; extremely high leakage current, which causes in line with, venting, and an open circuit.
Global environmental warnings (Greenhouse effects and other environmental destruction by depletion of the ozone layer), new types of cleaning agents have been developed and commercialized as substitutes for CFC-113,1,1,2-trichloroethylene and 1,1,1-trichloroethylene. The following are recommended as cleaning conditions for some of new cleaning agents.

–Higher alcohol system cleaning agents

Recommended cleaning agents:

Pine Alpha ST-100S (Arakawa Chemical)

Clean Through 750H, 750K, 750L, and 710M (Kao)

Technocare FRW-14 through 17 (Toshiba)

Cleaning conditions:

Using these cleaning agents capacitors are capable of withstanding immersion or ultrasonic cleaning for 10 minutes at a maximum liquid temperature of 60°C. Find optimum condition for washing, rinsing, and drying. Be sure not to rub the marking off the capacitor by contacting any other components or the PC board. Note that shower cleaning adversely affects the markings on the sleeve.

–Non-Halogenated Solvent Cleaning

AK225AES (Asahi Glass)

Cleaning conditions:

Solvent-proof capacitors are capable of withstanding any one of immersion, ultrasonic or vapor cleaning for 5 minutes; exception is 2 minutes max. for KRE, and KRE-BP series capacitors and 3 minutes for SRM series capacitors. However, from a view of the global environmental problems, these types of solvent will be banned in near future. We would recommend not using them as much as possible.

Isopropyl alcohol cleaning agents

IPA (Isopropyl Alcohol) is one of the most acceptable cleaning agents; it is necessary to maintain a flux content in the cleaning liquid at a maximum limit of 2 Wt. %.

5] Precautions for using adhesives and coating materials

- a) Do not use any adhesive and coating materials containing halogenated solvent.
- b) Verify the following before using adhesive and coating material.
 - Remove flux and dust leftover between the rubber seal and the PC board before applying adhesive or coating materials to the capacitor.
 - Dry and remove any residual cleaning agents before applying adhesive and coating materials to the capacitors. Do not cover over the whole surface of the rubber seal with the adhesive or coating materials.
 - For permissible heat conditions for curing adhesives or coating materials, follow the instructions in the catalogs or the product specifications of the capacitors.
 - Covering over the whole surface of the capacitor rubber seal with resin may result in a hazardous condition because the inside pressure cannot release completely. Also, a large amount of halogen ions in resins will cause the capacitors to fail because the halogen ions penetrate into the rubber seal and the inside of the capacitor.
- c) Some of coating material cannot be cured over the capacitor.

6] Fumigation

Fumigation process may be required when exporting the end electrical product. The process, actually halogenated ions, may cause the aluminum electrolytic capacitor to corrode. The fumigation solvent must not directly adhere to the electrical product and the solvent must be dried completely. Please consult us if solvent adheres to the aluminum electrolytic capacitors or drying condition is not satisfaction.

The Operation of Devices

- a) Do not touch a capacitor directly with bare hands.
- b) Do not short-circuit the terminal of a capacitor by letting it come into contact with any conductive object.

Also, do not spill electric-conductive liquid such as acid or alkaline solution over the capacitor.
- c) Do not use capacitors in circumstance where they would be

subject to exposure to the following materials exist or expose.

- Oil, water, salty water or damp location.
- Direct sunlight.
- Toxic gases such as hydrogen sulfide, sulfurous acid, nitrous acid, chlorine or its compounds, and ammonium.
- Ozone, ultraviolet rays or radiation.
- Severe vibration or mechanical shock conditions beyond the limits prescribed in the catalogs or product specification.

Maintenance Inspection

- a) Make periodic inspections of capacitors that have been used in industrial applications. Before inspection, turn off the power supply and carefully discharge the electricity in the capacitors. Verify the polarity when measuring the capacitors with a volt-ohm meter. Also, do not apply any mechanical stress to the terminals of the capacitors.
- b) The following items should be checked during the periodic inspections.
 - Significant damage in appearance : venting and electrolyte leakage.
 - Electrical characteristics: leakage current, capacitance, $\tan\delta$ and other characteristics prescribed in the catalogs or product specifications.

We recommend replacing the capacitors if the parts are out of specification.

In Case of Venting

- a) If a non-solid aluminum electrolytic capacitor expels gas when venting, it will discharge odors or smoke, or burn in the case of a short-circuit failure. Immediately turn off or unplug the main power supply of the device.
- b) When venting, a non-solid aluminum electrolytic capacitor blows out gas with a temperature of over 100°C. (A solid aluminum electrolytic capacitor discharges decomposition gas or burning gas while the outer resin case is burning.) Never expose the face close to a venting capacitor. If your eyes should inadvertently become exposed to the spouting gas or you inhale it, immediately flush the open eyes with large amounts of water and gargle with water respectively. If electrolyte is on the skin, wash the electrolyte away from the skin with soap and plenty of water. Do not lick the electrolyte of non-solid aluminum electrolytic capacitors.

Storage

We recommend the following conditions for storage.

- a) Do not store capacitors at a high temperature or in high humidity. Store the capacitors indoors at a temperature of 5 to 35°C and a humidity of less than 75%RH.
- b) Store the capacitors in places free from water, oil or salt water.
- c) Store the capacitors in places free from toxic gasses (hydrogen sulfide, sulfurous acid, chlorine, ammonium, etc.)
- d) Store the capacitors in places free from ozone, ultraviolet rays or radiation.
- e) Keep capacitors in the original package.

Disposal

Please consult a local specialist regarding the disposal of industrial waste when disposing aluminum electrolytic capacitors.

Catalogs

Specifications in catalogs may be subject to change without notice. For more details of precautions and guidelines for aluminum electrolytic capacitors, please refer to Engineering Bulletin No. 634A.

Structure of Aluminum Electrolytic Capacitors

The aluminum electrolytic capacitor contains an internal element of an anode foil, a cathode foil and paper separator rolled together, impregnated with an electrolyte, then attached to external terminals connecting the tabs with the anode or the cathode foils, and sealed in a can case.

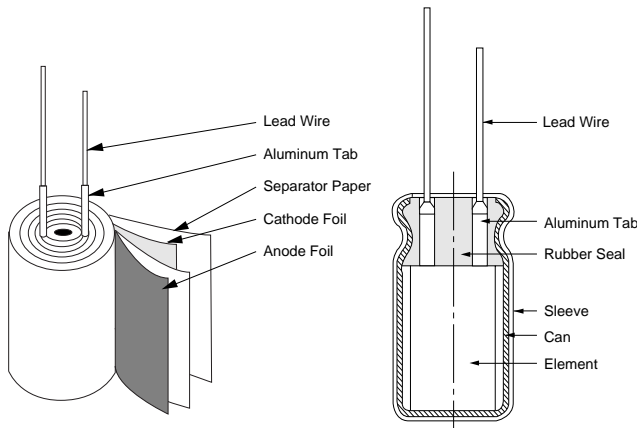

Among various types of capacitors, an aluminum electrolytic capacitor offers large CV to volume and features low cost. The capacitance (C) of aluminum electrolytic capacitors, as well as other capacitors, is expressed by the following equation:

$$C = 8.855 \times 10^{-12} \times \epsilon \times S / d \text{ (}\mu\text{F)}$$

Where: ϵ = Dielectric constant
 S = Surface area of dielectric (cm²)
 d = Thickness of dielectric (cm)

This equation shows that the capacitance increases in proportion as the dielectric constant becomes high, its surface area becomes large and the thickness of dielectric becomes thin. In aluminum electrolytic capacitors the dielectric constant of an aluminum oxide (Al₂O₃) layer is 8 to 10, which is not as high as compared with the other types of capacitors. However, the dielectric layer of the aluminum oxide is extremely thin (about 15Å per volt) and the surface area is very large. An electrochemical formed electrode foil makes the dielectric on the etched surface of aluminum electrode foil. Electrochemical etching creates 20 to 100 times more surface area as plain foil. Therefore, an aluminum electrolytic capacitor can offer a large capacitance compared with other types.

Primary of Composition Material

Anode aluminum foil:

First, the etching process is carried out electromechanically with a chloride solution which dissolves metal and increases the surface area of the foil; forming a dense network like innumerable microscopic channels. Secondly, the formation process is carried out with a solution such as ammonium borate which forms the aluminum oxide layer (Al₂O₃) as a dielectric at a thickness of 15Å / volt. The process needs to charge 140 to 200% of the rated voltage into the foil.

Cathode aluminum foil:

As in the first manufacturing process of the positive foil, the cathode foil requires etching process. Generally, it does not require the formation process; therefore, the natural oxide layer of Al₂O₃, which gives a characteristic dielectric voltage of 0.2 to 1.0 volts, is formed.

Electrolyte and separator:

In a non-solid aluminum electrolytic capacitor, the electrolyte, an electrically conductive liquid, functions as a true cathode by contacting the dielectric oxide layer. Accordingly, the "cathode foil" serves as an electrical connection between the electrolyte and terminal.

The separator functions to retain the electrolyte and prevent the anode and cathode foils from short-circuiting.

Can case and sealing materials:

The foils and separator are wound into a cylinder to make an internal element, which is impregnated with the electrolyte, inserted into an aluminum can case and sealed. During the service life of a capacitor, electrolyte slowly and naturally vaporizes by electrochemical reaction on the boundary of the aluminum foils. The gas will increase the pressure inside the case and finally cause the pressure relief vent to open or the sealing materials to bulge. The sealing material functions not only to prevent electrolyte from drying out but also to allow the gas to escape out of the can case in a controlled manner.

The Equivalent Circuit

As the equivalent circuit of an aluminum electrolytic capacitor is shown below, it forms a capacitance, a series resistance, an inductance, and a parallel resistance.

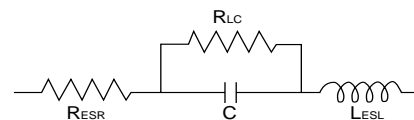

RESR = Equivalent series resistance (ESR)
 RLC = Resistance due to leakage current
 C = Capacitance
 LESL = Equivalent series inductance

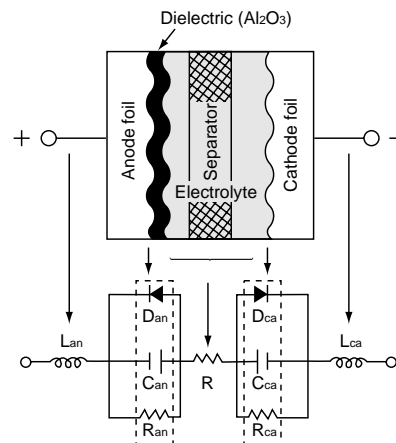

From a composition material point wise, the equivalent circuit is subdivided as follows.

Can, Cca = Capacitance due to anode and cathodes foils
 R = Resistance of electrolyte and separator
 Ran, Rca = Internal resistance of oxide layer on anode and cathode foils
 Dan, Dca = Diode effects due to oxide layer on anode and cathode foils
 Lan, Lca = Inductance due to anode and cathode terminals

Basic Electrical Characteristics

Capacitance:

The capacitance of capacitor is expressed as AC capacitance

by measuring impedance and separating factors. Also, the AC capacitance depends upon frequency, voltage and other measuring methods. In fact, JIS C 5101 prescribes that the series capacitive factor of an equivalent series(○—||—⊂—○) circuit shall be the capacitance measured at a frequency of 120Hz and applying a maximum AC voltage of 0.5V rms with a DC bias voltage of 1.5 or 2.0V to aluminum electrolytic capacitors. The capacitance of an aluminum electrolytic capacitor becomes smaller with increasing frequency. See the typical behavior shown below.

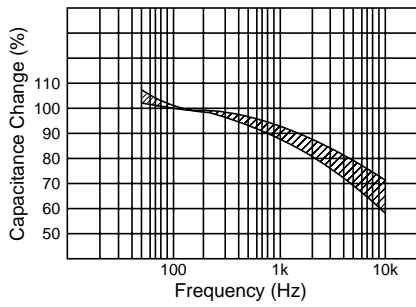

Capacitance VS. Frequency

The capacitance value is highly dependent upon temperature and frequency. As the temperature decreases, the capacitance becomes smaller. See the typical behavior shown below.

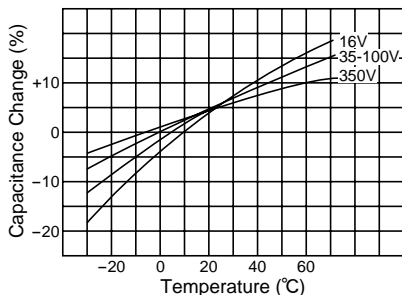

Temperature Characteristics of Capacitance

On the other hand, DC capacitance, which can be measured by applying a DC voltage, shows a slightly larger value than the AC capacitance at a normal temperature and has the flatter characteristic over the temperature range.

tanδ(tangent of loss angle or dissipation factor):

The tanδ is expressed as the ratio of the resistive component (RESR) to the capacitive reactance (1/ωC) in the equivalent series circuit. Its measuring conditions are the same as the capacitance.

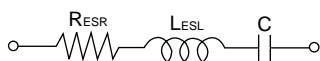

$$\tan\delta = R_{ESR} / (1/\omega C) = \omega C R_{ESR}$$

Where : $R_{ESR} = ESR$ at 120Hz
 $\omega = 2\pi f$
 $f = 120\text{Hz}$

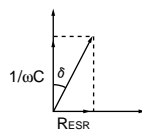

The tanδ shows higher values as the measured frequency increases and the measured temperature decreases.

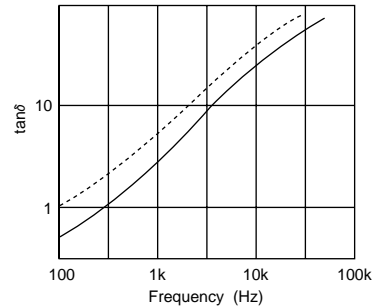

tanδ VS. Frequency

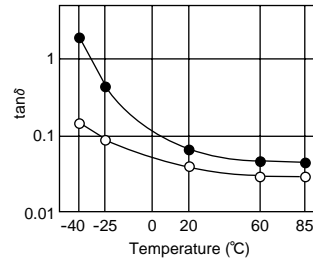

Temperature Characteristics of tanδ

Equivalent series resistance (ESR):

The ESR is the series resistance consisting of the aluminum oxide layer, electrolyte/separator combination, and other resistance related factors, foil length, foil surface area and others.

The ESR value depends upon the temperature. Decreasing the temperature makes the resistivity of the electrolyte increase and leads to increasing ESR.

As the measuring frequency increases, the ESR decreases and reaches an almost constant value that mainly dominates the frequency-independent resistance relating electrolyte/separator combination.

Impedance (Z):

The impedance is the resistance of the alternating current at a specific frequency. It is related to capacitance (C) and inductance (L) in terms of capacitive and inductive reactance, and also related to the ESR. It is expressed as follows:

$$Z = \sqrt{ESR^2 + (X_L - X_C)^2}$$

Where : $X_C = 1/\omega C = 1/2\pi f C$
 $X_L = \omega L = 2\pi f L$

As shown below, the capacitive reactance (Xc) dominates at the range of low frequencies, and the impedance decreases with increasing frequency until it reaches the ESR in the middle frequency range. At the range of the higher frequencies the inductive reactance (XL) comes to dominate, so that the impedance increases when increasing the measuring frequency.

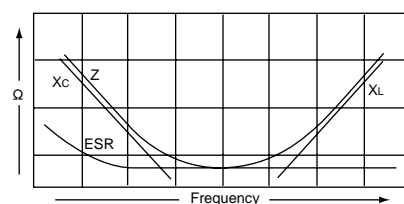

Impedance VS. Frequency

As shown at the next page, the impedance value varies with temperature because the resistance of the electrolyte is strongly affected by temperature.

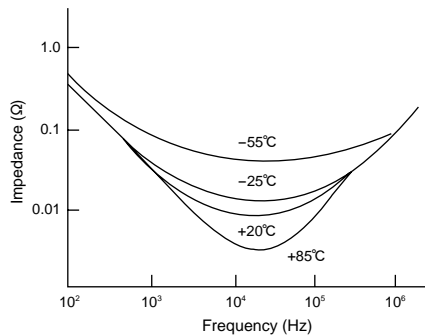

Temperature Characteristics of Impedance

Leakage current:

The dielectric of a capacitor has a very high resistance that does not allow DC current to flow. However, due to the characteristics of the aluminum oxide layer that functions as a dielectric in contact with electrolyte, a small amount of current, called leakage current, will flow to reform and repair the oxide layer when a voltage is being applied. As shown below, a high leakage current flows to charge voltage to the capacitor for the first seconds, and then the leakage current will decrease and reach an almost steady-state value with time.

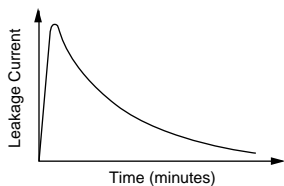

Leakage Current VS. Time

Measuring temperature and voltage influences the leakage current. The leakage current shows higher values as the temperature and voltage increase.

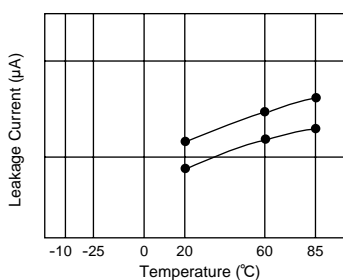

Typical Temperature Characteristics

In general, the leakage current is measured at 20°C by applying the rated voltage to capacitor through a resistor of 1000Ω in series. The leakage current is the value several minutes later after the capacitor has reached the rated voltage. The catalog prescribes the measuring temperature and time.

Reliability

The bathtub curve:

Aluminum electrolytic capacitors feature failure rates shown by the following bathtub curve.

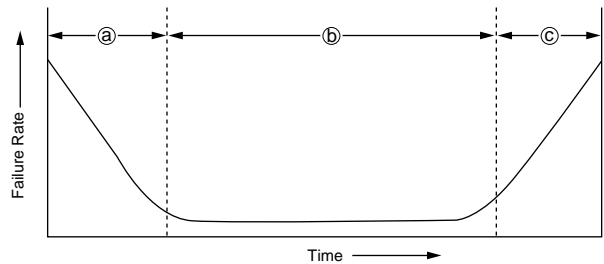

a) Infant failure period

This initial period accounts for the failures caused by deficiencies in design, structure, the manufacturing process or severe misapplications. In other words the initial failures occur as soon as the components are installed in a circuit. In the case of aluminum electrolytic capacitors, these failures do not occur at customers, field because aging process reforms an incomplete oxide layer, or eliminate the defective parts at the aging process and the sorting process.

Misapplication of the capacitor such as inappropriate ambient conditions, over-voltage, reverse voltage, or excessive ripple current should be avoided for proper use of the capacitor in a circuit.

b) Useful life period

This random failure period exhibits an extremely low failure rate. These failures are not related to operating time but to application conditions. During this period, non-solid aluminum electrolytic capacitors lose a small amount of electrolyte. The electrolyte loss shows as a slow decrease in capacitance and a slow increase in $\tan\delta$ and ESR. Non-solid aluminum electrolytic capacitors still exhibit lower catastrophic failures than semiconductors and solid tantalum capacitors.

c) Wear-out failure period

This period reflects a deterioration in the component properties of the capacitor ; the failure rate increases with time. Non-solid aluminum electrolytic capacitors end their useful life during this period.

Failure types:

The two types of failures are classified as catastrophic failures and wear-out failures as follows.

1) Catastrophic failures

This is a failure mode that destroys the function of the capacitor like a short circuit or open circuit failure.

2) Wear-out failures

This is a failure mode where gradually deteriorates; the electrical parameters of the capacitor. The criteria of judging the failures, vary with application and design factors. Capacitance decreases and $\tan\delta$ increases are caused by the loss of electrolyte in the wear-out failure period. This is primary due to loss of electrolyte by diffusion (as vapor) through the sealing material. Gas molecules can diffuse out through the material of the end seal. High temperature increase the electrolyte vapor pressure within the capacitor and the diffusion rate is therefore increased. This increases internal pressure may cause the seal to bulge caused by elevated temperatures. This bulging may accelerate diffusion and mechanically degrade the seal. Factors that can increase the capacitor temperature, such as ambient temperature and ripple current, can accelerate the wear-out phase of a capacitor.

Failure modes:

Aluminum electrolytic capacitors show various failure modes in different applications.(See Table 1.)

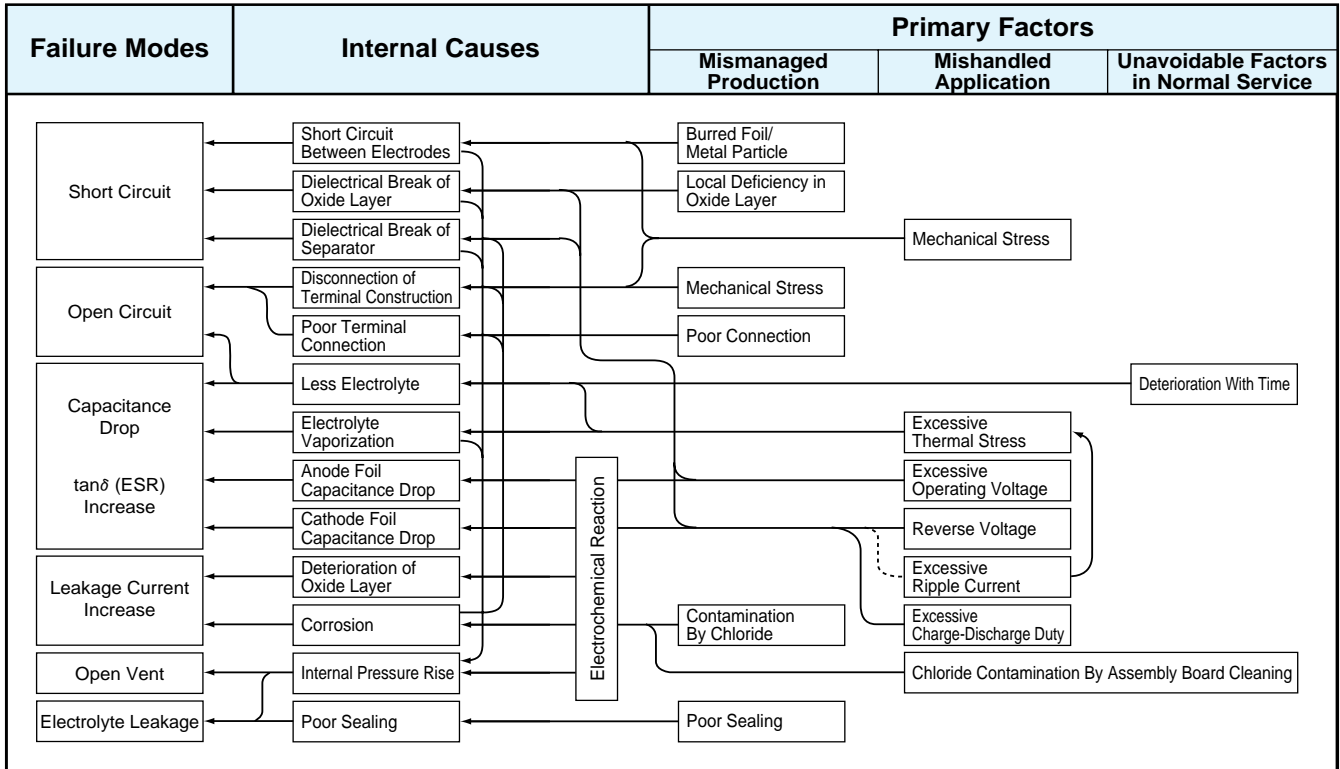

Table1

Life of Aluminum Electrolytic Capacitors

The life of aluminum electrolytic capacitors is largely dependent on environmental and electrical factors. Environmental factors include temperature, humidity, atmospheric pressure and vibration. Electrical factors include operating voltage, ripple current and charge-discharge duty cycles. The factor of temperature (ambient temperature and internal heating due to ripple current) is the most critical to the life of aluminum electrolytic capacitors.

General formula to estimate lifetime:

The lifetime of non-solid aluminum electrolytic capacitors is generally expressed by using three elements representing the effects of ambient temperature, applying voltage and ripple current, which is shown by the following equation:

$$L_x = L_0 \cdot K_{Temp} \cdot K_{Voltage} \cdot K_{Ripple}$$

Where : L_x =Lifetime of capacitor to be estimated
 L_0 =Base lifetime of capacitor
 K_{Temp} =Ambient temperature acceleration term
 $K_{Voltage}$ =Voltage acceleration term
 K_{Ripple} =Ripple current acceleration term

K_{Temp} (Effects of ambient temperature on life):

Because an aluminum electrolytic capacitor is essentially an electrochemical component, increased temperatures accelerate the chemical reaction producing gas within the capacitor which is diffused through the end seal, and consequently accelerates a gradual decrease in capacitance and a gradual increase in $\tan\delta$ and ESR. The following equation has been experimentally found to express the relationship between the temperature acceleration factor and the deterioration of the capacitor.

$$L_x = L_0 \cdot K_{Temp} = L_0 \cdot B^{(T_0 - T_x) / 10}$$

$$K_{Temp} = B^{(T_0 - T_x) / 10}$$

Where : L_x =Lifetime (hour) of capacitor to be estimated
 L_0 =Base lifetime (hour) of capacitor
 T_0 =Maximum rated operating temperature (°C) of capacitor shown in catalog
 T_x =Actual ambient temperature (°C) of capacitor
 B =Temperature acceleration factor (≈ 2)

This equation is similar to Arrhenius' equation that expresses a relationship between chemical reaction rates and temperature, and called Arrhenius' rule of aluminum electrolytic capacitors. The temperature acceleration factor (B) is approximately 2 over an ambient temperature range (T_x) from 40°C to the maximum rated operating temperature of each capacitor. It means that the lifetime is approximately halved with every 10°C rise in ambient temperature and can be extended by using the capacitors at low temperatures. For an ambient temperature range (T_x) of 20°C to 40°C, the factor B will be close to 2, and the lifetime will actually be extended. However, operating and surrounding conditions, especially the operating conditions influence ambient temperatures mutually. The ambient temperature in this range will be very changeable; therefore, lifetime estimation under 40°C should use 40 as T_x .

$K_{Voltage}$ (Effects of applying voltage to life):

Miniature and large sized aluminum electrolytic capacitors for popular applications, such as surface mount types, radial lead types, snap-in types and block types, have little voltage effect on their life. Other factors like temperature and ripple current determine the life in comparison with voltage, as long as the capacitors are used at voltages and temperatures within the specifications prescribed in the catalog. Consequently, $K_{Voltage} = 1$ is used for these capacitors. 350V and higher screw-mount terminal types of capacitors for customer-use power electronics applications allow the life time to extend by applying low voltage, relating to the characteristics of their aluminum oxide layer. RWE, RWY, RWL, RWF, LX(Screw-mount), LXA(Screw-mount) and LXR series are applicable to the method. For $K_{Voltage}$ values of these products, please contact a representative of Nippon Chemi-Con.

K_{Ripple} (Effects of ripple current to life):

Aluminum electrolytic capacitors have higher $\tan\delta$ than any other types of capacitors; therefore, the ripple current gives aluminum electrolytic capacitors higher internal heat. Be sure to check the maximum permissible ripple current which is specified in the catalog for assuring the life.

The ripple current through the capacitor produces heat by dissipating power from the capacitor. This leads to temperature increase. Internal heating produced by ripple currents can be expressed by:

$$W = (I_{\text{Ripple}})^2 \cdot R_{\text{ESR}} + V \cdot I_{\text{Leakage}}$$

Where : W = Internal power loss
 I_{Ripple} = R.M.S. ripple current
 R_{ESR} = Internal resistance (ESR) at ripple frequency
 V = Applied voltage
 I_{Leakage} = Leakage current

Leakage current may be 5 to 10 times higher than the values measured at 20°C, but compared with ripple, the leakage current value is very small and negligible. Thus, the above equation can be simplified:

$$W = (I_{\text{Ripple}})^2 \cdot R_{\text{ESR}}$$

The following equation gives the internal heat rise; it is heat rise to stable condition. (It is necessary to input several factors.):

$$(I_{\text{Ripple}})^2 \cdot R_{\text{ESR}} = \beta \cdot A \cdot \Delta T$$

Where : β = Heat transfer constant
 A = Surface area of can case
 $A = (\pi/4) \cdot D \cdot (D+4L)$
 Where : D = Can diameter
 L = Can length
 ΔT = An increase in core temperature by internal heating due to ripple current
 $(\Delta T = \text{Core temperature} - \text{Ambient temperature})$

From the above equation, internal temperature rise (ΔT) produced by ripple current is given by:

$$\Delta T = (I_{\text{Ripple}})^2 \cdot R_{\text{ESR}} / (\beta \cdot A)$$

When the ripple frequency is 120Hz, R_{ESR} at 120Hz is expressed by
 $R_{\text{ESR}} = \tan \delta / (\omega \cdot C)$
 $\Delta T = (I_{\text{Ripple}})^2 \cdot \tan \delta / (\beta \cdot A \cdot \omega \cdot C)$
 Where : $\tan \delta$ = 120Hz value
 $\omega = 2\pi \cdot f = 2\pi \cdot 120\text{Hz}$
 C = 120Hz capacitance value

As above equation, ΔT varies with frequency of ripple, frequency and temperature dependent ESR, and application dependent β (even ripple current is constant). We really recommend that customers measure ΔT with a thermocouple at the actual operating conditions of the application in lieu of using the above equation. (Another approximation of ΔT will be stated later.)

As mentioned in the paragraph of K_{Temp} , aluminum electrolytic capacitors will slowly increase in $\tan \delta$ and ESR during their service life. The application without ripple current has no influence on the life of the capacitor even though the ESR will increase during life. In other words, the application with ripple current makes ΔT increase; furthermore, a ΔT increase results in ESR increase. The ESR increase then makes ΔT increase. It is a chain reaction. Theoretically, the ripple current acceleration term (K_{Ripple}) cannot be simply expressed like the ambient temperature acceleration term (K_{Temp}). Practically, the ripple current acceleration term (K_{Ripple}) can be approximately expressed by an equation using a ΔT initially measured. The following table shows the ripple current acceleration term (K_{Ripple}) for each capacitor design group.

K_{Ripple}	Products		
	Type	Series	
$2^{(-\Delta T/5)}$	Surface mount (FC/FD/VC)	MFS/MFA, MF, MFK, MFY, MFJ, MF-BP, MFK-BP, MVA, MVS, MV, MVK, MVH, MVE, MVL, MVY, MV-BP, MVK-BP, MVJ, MFK-large	
	Radial lead (VB)	GXD, KMA, KME-BP, KRE, KMY, KRG, LLA, LX, LXA, SME, SME-BP, SMG, SRA, SRE, SRG, SRM, SXE	
	Screw-mount terminal (LG)	KW	
$2^{(\Delta T_{\text{to}} - \Delta T)/5}$	$\Delta T_{\text{to}} = 5 \text{ deg}$	Radial lead (VB)	FL, GXE ($T_{\text{to}} \leq 105^\circ\text{C}$), KLG, KME, KMF, KMG, KMH, KMX, LBG, LXJ, LXV, LXW, LXZ, KY, KZE
		Pin terminal (VN/VS/VR)	KLK, KLH, KMH, KMM, KMQ, KSL, LXG, LXM, LXH
		Screw-mount terminal (LG)	LXA (10 to 250V _{dc}), KMH
	$\Delta T_{\text{to}} = 5 \text{ to } 10 \text{ deg}$ Contact us for details	Radial lead (VB)	SMH
		Pin terminal (VN/VS/VR/LASN)	SMH, SMM, SMQ, SLM, RWE-LR
		Screw-mount terminal (LG)	SME
$2^{[-2+(25-\Delta T)/b]}$	Screw-insert terminal (LG)	LX, LXA (350 to 525V _{dc}), RWE, RWF, RWL, LXR, RWY	

Note : ΔT = An increase (deg) in core temperature produced by internal heating due to actual operating ripple current. The ΔT is the difference between the core temperature and ambient temperature measured at the actual operating conditions.
 ΔT_{to} = An increase (deg) in core temperature by internal heating due to rated maximum permissible ripple current.
 b = Factor b varies from 5 to 10 by the conditions of ripple frequency and ΔT . Please contact a representative of Nippon Chemi-Con for the details

Note that a ΔT over a certain maximum limit may over-heat the capacitors, though the lifetime estimation will not give you practical lifetime. For instance, the following shows a guide limit of ΔT at each ambient temperature for 105°C maximum rated products.

Ambient temperature T_x (°C)	40	55	65	85	105
Guide limit of ΔT (deg)	30	30	25	15	5
Core temperature (= $T_x + \Delta T$)	70	85	90	100	110

Approximation of ΔT

Estimation of the lifetime requires two temperature measurements; first obtain ΔT by actually measuring the core temperature, inserting the thermocouple inside the operating capacitor and secondary, the ambient temperature. A more convenient way to get the ΔT is to convert the surface temperature of the capacitor case and the ambient temperature by using a coefficient specified for each case diameter as follows:

$$\Delta T = K_c \cdot (T_s - T_x)$$

Where : K_c = Coefficient from table below
 T_s = Surface temperature (deg) of capacitor can case
 T_x = Ambient temperature (deg)

No air flow conditions.

Diameter (mm)	φ5 to φ8	φ10	φ12.5	φ16	φ18	φ22	φ25	
K_c	1.10	1.15	1.20	1.25	1.30	1.35	1.40	
Diameter (mm)	φ30	φ35	φ40	φ50	φ63.5	φ76	φ89	φ100
K_c	1.50	1.65	1.75	1.90	2.20	2.50	2.80	3.10

Also, you can roughly estimate a ΔT by using the following equation without need to measure.

$$\Delta T = \Delta T \cdot (I_x / I_0)^2$$

Where : $\Delta T = 5$ deg for 105°C maximum rated capacitors.

I_0 = Rated maximum permissible ripple current (ARMS) : if its frequency is different from operating ripple current I_x , it needs converting by using a frequency multiplier prescribed in the catalog.

I_k = Operating ripple current (ARMS) actually flowing into a capacitor

Like switching power supplies, if the operating ripple current consists of commercial frequency element and switching frequency element(s), an internal power loss is expressed by the following equation.

$$W = (I_{f1})^2 \cdot ESR_{f1} + (I_{f2})^2 \cdot ESR_{f2} + \dots + (I_{fn})^2 \cdot ESR_{fn}$$

Where : W = Internal power loss
 $I_{f1} \dots I_{fn}$ = Ripple currents at every frequencies $f1 \dots fn$
 $ESR_{f1} \dots ESR_{fn}$ = ESR's at every frequencies $f1 \dots fn$

The above equation can be transformed into another equation to get a ripple current value in accordance with the frequency of the rated maximum permissible ripple current, each of $ESR_{f1}, \dots, ESR_{fn}$ is approximately equal to ESR_{f0} divided by square value of the frequency multiplier ($F_{f1} \dots F_{fn}$). Here ESR_{f0} is the value at the frequency of the rated maximum permissible ripple current and $F_{f1} \dots F_{fn}$ is a conversion coefficient from one frequency to another in accordance with the frequency $f1 \dots fn$.

$$\begin{aligned} ESR_{f1} &= ESR_{f0} / (F_{f1})^2 \\ &\vdots \\ ESR_{fn} &= ESR_{f0} / (F_{fn})^2 \end{aligned}$$

Relationship of $w = (L_{\text{Ripple}})^2 \cdot RESR$ leads I_x as follows:

$$I_x = \sqrt{W / ESR_{f0}}$$

The above is rewritten in the following equation:

$$I_x = \sqrt{(I_{f1}/F_{f1})^2 + (I_{f2}/F_{f2})^2 + \dots + (I_{fn}/F_{fn})^2}$$

Where : I_x = Ripple current in accordance with the frequency of the rated max. permissible ripple current

$I_{f1} \dots I_{fn}$ = Operating ripple currents at every frequency $f1 \dots fn$

$F_{f1} \dots F_{fn}$ = Frequency multipliers for every frequency $f1 \dots fn$ prescribed in the catalog, based on the fact that the internal resistance of a capacitor varies with frequency.

Cleaning Agents

- Cleaning agents penetrate into a capacitor.
Solvent contacts the rubber seal of a capacitor. Some percentage of solvent does not penetrate but a percentage succeeds in entering and defusing inside the capacitor.
- Cleaning agents decompose and release halogen ions.
In the electrolyte of the inside element, the halides in the cleaning agents become hydrolyzed and release halogen ions as follows,

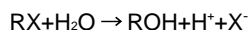

RX : Halide

X^- : Halogen ion

c. Corrosion

The halogen ions attack the aluminum foil by the following anodic half-cell reaction:

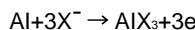

The AlX_3 further becomes hydrolyzed and release the halogen ion again:



The halogen ions release by this hydrolysis reaction further attacks the aluminum according to the previous reaction formula, and these reactions are repeated and accelerated when voltage and temperature is applied. Also, the hydrogen ions increase the local acidity which causes the oxide dielectric to dissolve. Thus, localized corrosion accelerates to corrode both the aluminum metal and the dielectric. In addition, a terpene or petroleum system cleaning solvent will be absorbed into the rubber seal of the capacitor. The rubber seal finally weakens. An alkaline saponification detergent will damage the aluminum metal and marking. In summary, recommended cleaning agents are halogen free. Terpene, petroleum, alkali detergent and any solvent making the rubber seal material deteriorate are not recommended.

Compatible cleaning agents:

In line with recent global environmental warnings (Greenhouse effect and other environmental destruction by depletion of the ozone layer), new types of cleaning agents have been commercialized and substituted as CFC-113, 1,1,2-trichloroethylene and 1,1,1-trichloroethylene. The following are recommended cleaning conditions for some of new cleaning agents.

Higher alcohol system cleaning agents

Recommended cleaning agents:

Pine Alpha ST-100S (Arakawa Chemical)

Clean Through 750H, 750K, 750L, and 710M (Kao)

Technocare FRW-14 through 17 (Toshiba)

Cleaning conditions:

- Capacitors are capable of withstanding immersion or ultrasonic cleaning for 10 minutes at a maximum liquid temperature of 60°C using the above cleaning agents. Find the optimum conditions for washing, rinsing, and drying. Be sure not to rub the marking off the capacitor by contact with any other components on the PC board. Note that shower cleaning adversely affects the marking.
- To rinse by water, control the conditions such as temperature and water pressure to avoid sleeve shrinkage.
- Clean Through 750H and similar are weak-alkaline solvents. Do not leave the alkaline on the capacitor after cleaning process.

CFCs substitute solvents(HCFC system)

Asahi Glass AK225AES solvent is usable only with solvent-proof type capacitors, which are designed with reinforced seal constructions and modified electrolyte. This product does not penetrate the capacitor and deactivate halogen ions. However, AK225AES is one of the solvents which will have a restricted usage in future from the environmental point of view.

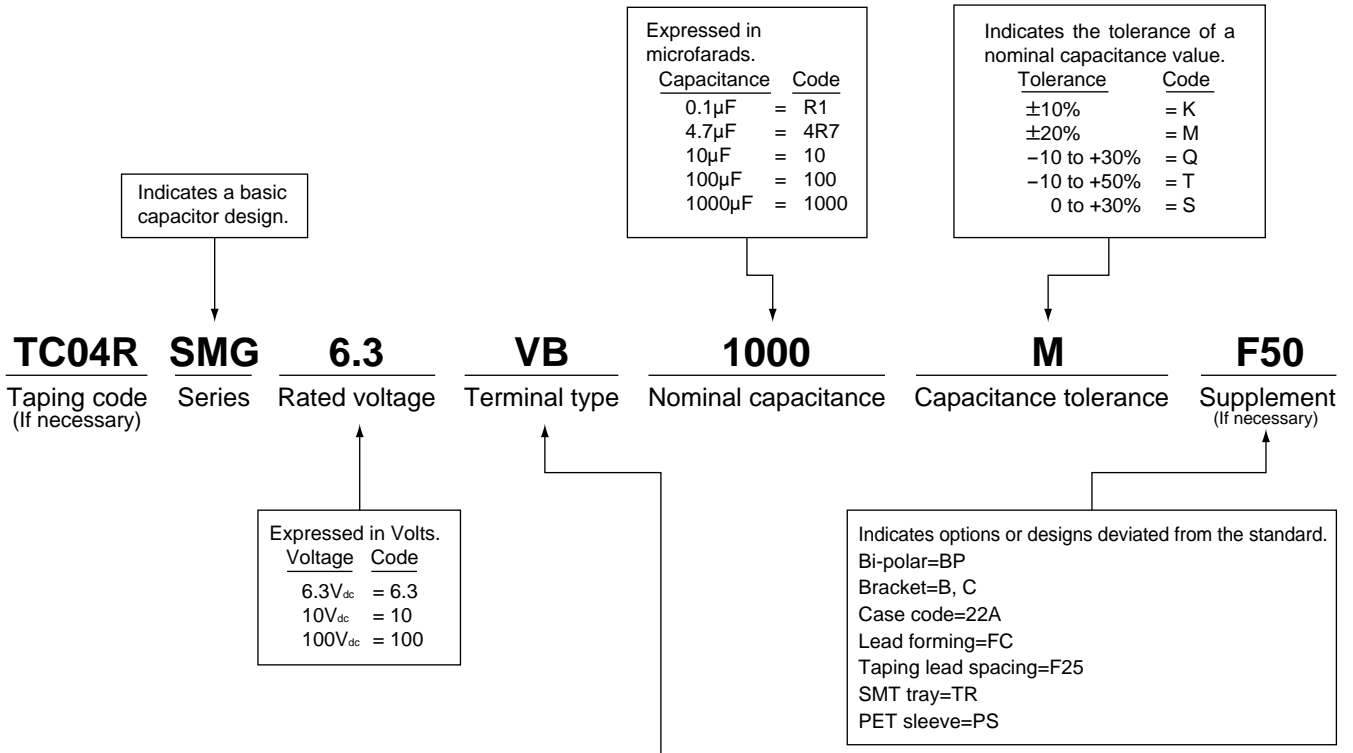

Indicates basic terminal type of capacitors.

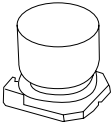
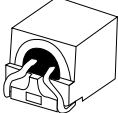
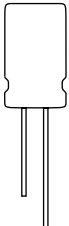
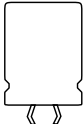
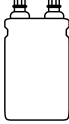
Type code=VC	Type code=FC	Type code=VB	Type code=VSSN	Type code=LGSN
Vertical SMT	Horizontal SMT	Radial lead	Snap-in terminal for large-sized capacitors	Screw-mount terminal
	 Dummy terminal=FD			

◆TAPING CODE (only applicable for radial type)

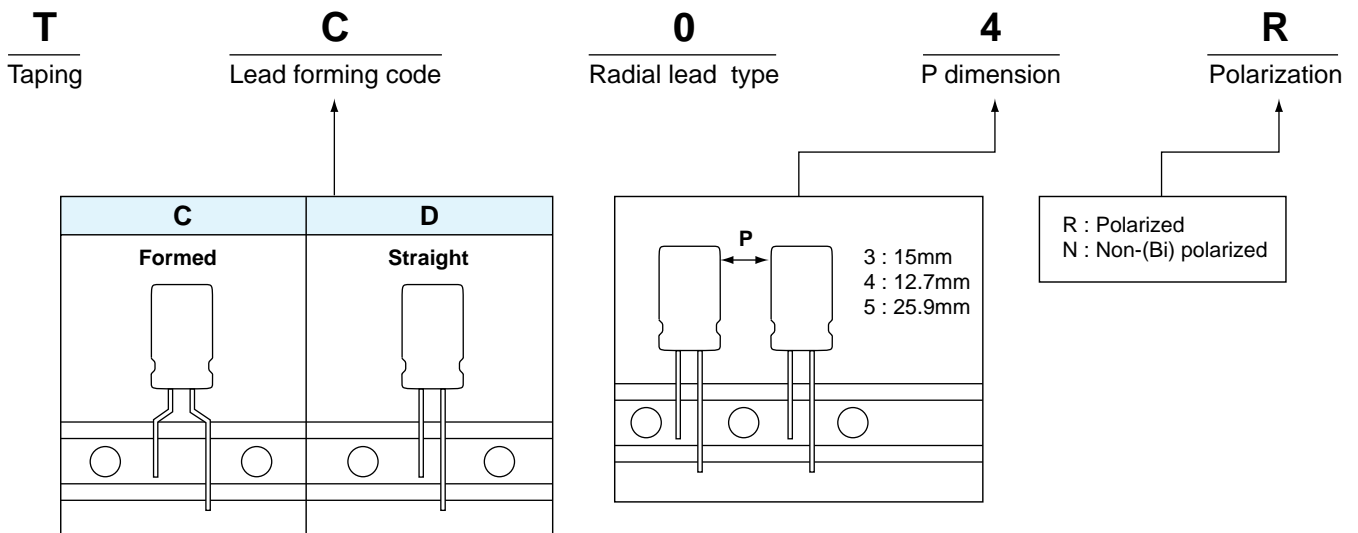



MINIMUM ORDER QUANTITY

Please order by units of minimum order quantity.

◆SURFACE MOUNT

●Horizontal



Series	Case code	Quantity (pcs)
Alchip® MFS/MFA/MF/MFK MFY/MFJ PX (Horizontal) MFZ/MFX	A6	3,000
	B46, B6	3,000
	C46, C6	2,500
	D46, D6, D8, D80, D10, D13	2,500
	E8	2,000
	H15, H20, H25	500

●Vertical



Series	Case code	Quantity (pcs)	
		Taping	Tray
Alchip® MVS/MVA/MV/ MVK/MVY/MVJ MVH/MVE/MVL PX(Vertical)	B55	2,000	—
	D46, D55, D60	2,000	—
	E46, E55, E60	1,000	—
	F46, F55, F60	1,000	—
	F80	900	—
	H63	1,000	—
	H70, H10	500	—
	J80, J10	500	—
	K14	200	120
	K16	150	120
	L17, L22	—	80
	M17, M22	—	60

◆RADIAL



Size	Quantity (pcs)	
	Bulk	Taping
φ3 (φ3.5)	200	3,000
φ4	200	2,000
φ5	200	2,000
φ6.3	200	2,000
φ8 (φ7)	200	1,000
φ10	Height ≤ 25mm	800
	Height ≥ 30mm	500
φ12.5	100	500
φ16	50	250
φ18	50	250

* : The quantity of bulk is a typical example.

◆SNAP-INS



200 pieces

SURFACE MOUNT TYPE (TAPING)



◆CARRIER TAPE [mm]

Fig.1

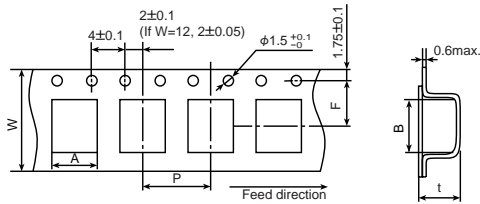

Fig.4

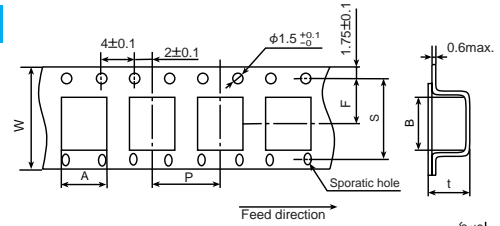

Fig.2

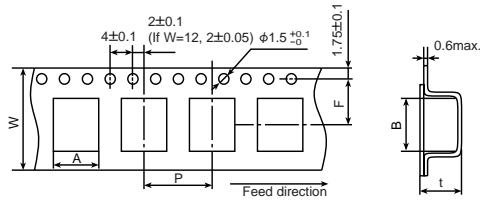

Fig.5

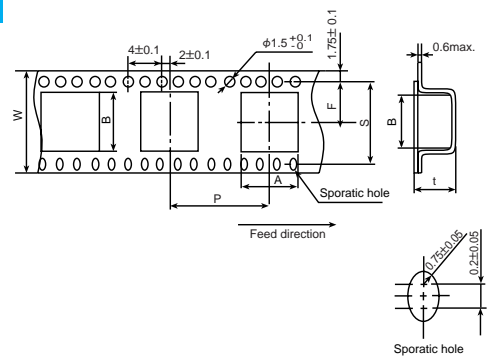
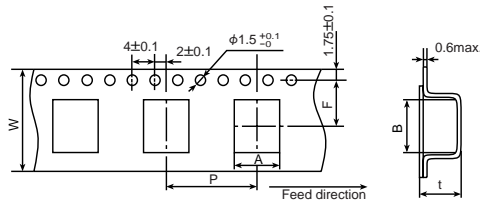

Fig.3



[mm]

Series	Items	W	A	B	F	P	t	S	Fig.
		±0.3	±0.2	±0.2	±0.1	±0.1	±0.2	±0.1	
Alchip® MFS/MFA MF/MFK MFY/MFJ PX (Horizontal) MFZ/MFX	A6	12.0	3.7	6.7	5.5	8.0	3.5	—	1
	B46	12.0	4.2	5.2	5.5	8.0	4.0	—	1
	B6	12.0	4.2	6.7	5.5	8.0	4.0	—	1
	C46	12.0	4.7	5.2	5.5	8.0	4.5	—	1
	C6	12.0	4.7	6.7	5.5	8.0	4.5	—	1
	D46	12.0	5.2	5.2	5.5	8.0	5.0	—	1
	D6	12.0	5.2	6.7	5.5	8.0	5.0	—	1
	D8 (D80)	16.0	5.2	8.7	7.5	8.0	5.0	—	1
	D10	16.0	5.2	10.7	7.5	8.0	5.0	—	1
	D13	24.0	5.2	13.7	11.5	8.0	5.0	—	1
	E8	16.0	7.5	8.8	7.5	8.0	6.0	—	1
	H15	24.0	9.2	17.3	11.5	16.0	9.9	—	3
	H20	32.0	9.2	21.8	14.2	16.0	9.9	28.4	4
H25	44.0	9.2	26.8	20.2	16.0	9.9	40.4	4	
Alchip® MVS/MVA MVE/MV MVK/MVY MVJ/MVH MVL PX(Vertical)	B55	12.0	3.5	3.5	5.5	8.0	5.9	—	1
	D46	12.0	4.7	4.7	5.5	8.0	4.9	—	1
	D55	12.0	4.7	4.7	5.5	8.0	5.7	—	1
	D60	12.0	4.7	4.7	5.5	8.0	6.3	—	1
	E46	12.0	5.7	5.7	5.5	12.0	4.9	—	2
	E55	12.0	5.7	5.7	5.5	12.0	5.7	—	2
	E60	12.0	5.7	5.7	5.5	12.0	6.3	—	2
	F46	16.0	7.0	7.0	7.5	12.0	4.9	—	2
	F55	16.0	7.0	7.0	7.5	12.0	5.7	—	2
	F60	16.0	7.0	7.0	7.5	12.0	* 6.3	—	2
	F80	16.0	7.0	7.0	7.5	12.0	8.2	—	2
	H63	16.0	8.7	8.7	7.5	12.0	6.8	—	2
	H70	24.0	8.7	8.7	11.5	12.0	7.2	—	3
	H10	24.0	8.7	8.7	11.5	16.0	11.0	—	3
	J80	24.0	10.7	10.7	11.5	16.0	8.2	—	3
J10	24.0	10.7	10.7	11.5	16.0	11.0	—	3	
K14	32.0	13.4	13.4	14.2	24.0	14.0	28.4	5	
K16	32.0	13.4	13.4	14.2	24.0	16.5	28.4	5	

*:tolerance±0.3

◆ REEL DIMENSIONS [mm]

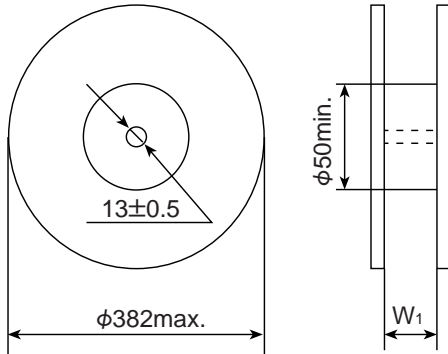

◆ QUANTITY PER REEL/BOX

Series	Case code	Quantity (pcs/reel)	Quantity (pcs/box)	W ₁ (mm)	
Alchip [®] MFS/MFA/ MF/MFK MFY/MFJ	A6	3,000	15,000	14	
	B46, B6	3,000	15,000	14	
	C46, C6	2,500	12,500	14	
	D46, D6	2,500	12,500	14	
	D8, D80, D10	2,500	12,500	18	
	D13	2,500	7,500	26	
	PX (Horizontal) MFZ/MFX	E8	2,000	10,000	18
		H15	500	1,500	26
		H20	500	1,000	34
		H25	500	1,000	46
Alchip [®] MVS/MVA MV/MVK MVY/MVJ MVH/MVE /MVL		B55	2,000	10,000	14
	D46, D55, D60	2,000	10,000	14	
	E46, E55, E60	1,000	5,000	14	
	F46, F55, F60	1,000	5,000	18	
	F80	900	4,500	18	
	H63	1,000	5,000	18	
	H70, H10	500	1,500	26	
	PX(Vertical)	J80, J10	500	1,500	26
		K14	200	600	34
		K16	150	450	34

◆ POLARITY

Alchip[®] MFS/MFA/MF
(Horizontal) MFK/MFY/MFJ
PX/MFZ/MFX

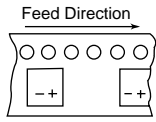

Alchip[®] MVS/MV/MVK
(Vertical) MVY/MVJ/MVH/
MVE/MVL/PX

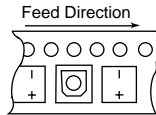

SURFACE MOUNT TYPE (TRAY)

◆ DIMENSIONS [mm]

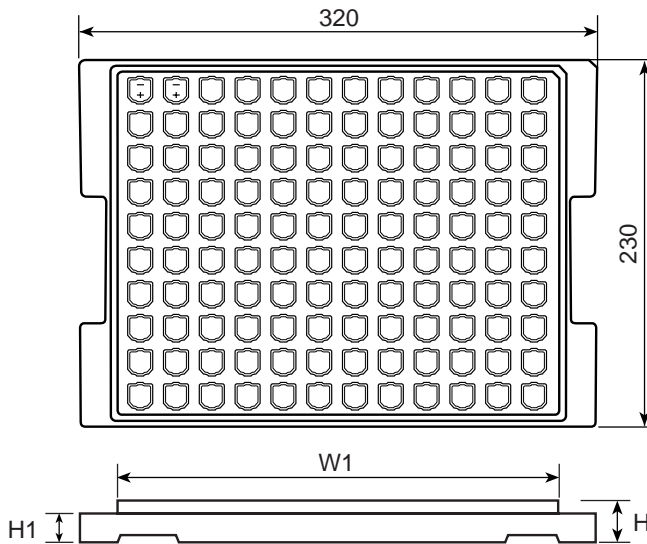

Case code	H [mm]	W ₁ [mm]	H ₁ [mm]
K14 & K16	21.0	284	18.5
L17 & L22	28.0	284	24.0
M17 & M22	28.0	284	24.0

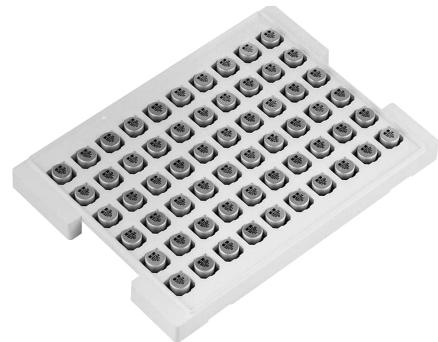

◆ QUANTITY PER TRAY

Case code	Quantity (pcs/tray)	Quantity (pcs/box)
K14 & K16	120	600
L17 & L22	80	400
M17 & M22	60	300

◆ TRAY CODE

Example

Capacitor's D/N TR
MVE6.3VC 4700M L22TR

RADIAL LEAD TYPE



◆CARRIER TAPE [mm]

Fig.1

φD=φ3 to 8

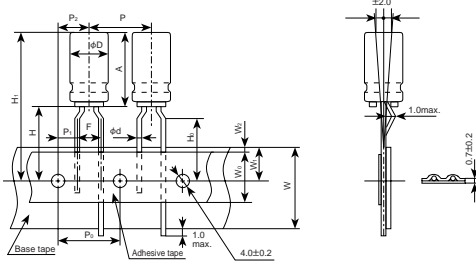

Fig.2

φD=φ5
φD×L=φ4×7

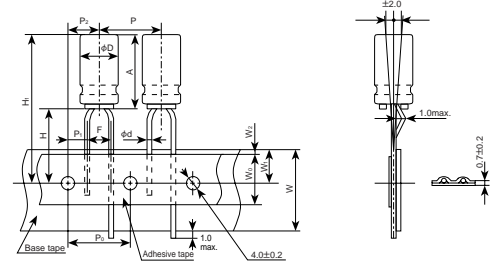

Fig.3

φD=φ6.3 to 8
φD=φ10 & 12.5

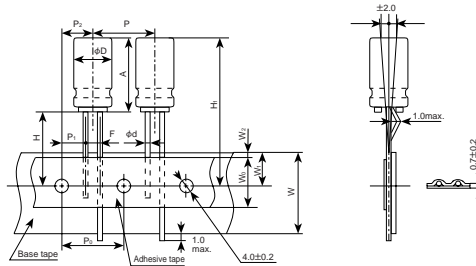
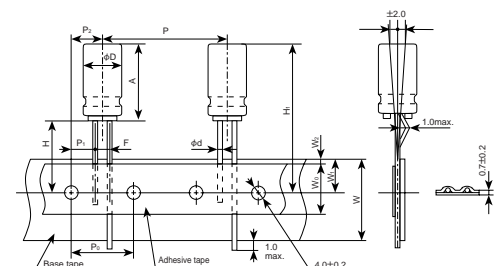

Fig.4

φD=φ12.5



Code	Case size		φd	P	P ₀	P ₁	P ₂	F	W	W ₀	W ₁	W ₂	H	H ₀	H ₁	Fig.	Taping code
	φD	A															
tol.	—	—	±0.05	±1.0	±0.2	±0.7	±1.0	+0.8 -0.2	±0.5	min.	±0.5	max.	±0.75	±0.5			
Nominal	3	5	0.4	12.7	12.7	5.1	6.35	2.5	18.0	6.0	9.0	1.5	17.5	16.0	Check insertion machine specs. H ₁ =H+A	1	TC04R F25
		3.5	0.4	12.7	12.7	5.1	6.35	2.5	18.0	6.0	9.0	1.5	17.5	16.0		1	TC04R F25
	4	5 to 7	0.45	12.7	12.7	5.1 3.85	6.35	2.5 5	18.0	6.0	9.0	1.5	17.5	16.0		2	TD04R F25
		9 to 11.5	0.45	12.7	12.7	5.1 3.85	6.35	2.5 5	18.0	10.0	9.0	1.5	17.5	16.0		1	TC04R F50
	5	5 to 7	0.45	12.7	12.7	5.1 3.85	6.35	2.5 5	18.0	6.0	9.0	1.5	18.5	16.0		2	TD04R F25
		9 to 15	0.5	12.7	12.7	5.1 3.85	6.35	2.5 5	18.0	10.0	9.0	1.5	18.5	16.0		1	TC04R F50
	6.3	5 to 7	0.45	12.7	12.7	5.1 3.85	6.35	2.5 5	18.0	6.0	9.0	1.5	18.5	16.0		3	TD04R F25
		9 to 15	0.5	12.7	12.7	5.1 3.85	6.35	2.5 5	18.0	10.0	9.0	1.5	18.5	16.0		1	TC04R F50
	7	5	0.45	12.7	12.7	5.1 3.85	6.35	2.5 5	18.0	6.0	9.0	1.5	17.5	16.0		3	TD04R F25
		7	0.45	12.7	12.7	3.85	6.35	5	18.0	6.0	9.0	1.5	17.5	16.0		1	TC04R F50
	8	5	0.45	12.7	12.7	3.85	6.35	5	18.0	6.0	9.0	1.5	17.5	16.0		3	TD04R F25
		7 to 20	0.6	12.7	12.7	3.85	6.35	5	18.0	10.0	9.0	1.5	20.0	16.0		1	TC04R F50
Nominal	10	21	0.6	12.7	12.7	3.85	6.35	5	18.0	12.5	9.0	1.5	18.0	—	3	TD04R F50 H18	
		12.5	26	0.6	15	5.0	7.5	5	18.0	12.5	9.0	1.5	18.0	—	3	TD03R F50 H18	
				26	0.6	25.4	12.7	3.85	6.35	5	18.0	12.5	9.0	1.5	18.0	—	4

* 1 : For φ4×7 (A=7, F=25), shall be 18.5^{-0.5/+0.75} (code : TD04R F25) at Fig.2.

* 2 : P=15 taping is not standard. Use P=25.4 taping.

TAPING CODE

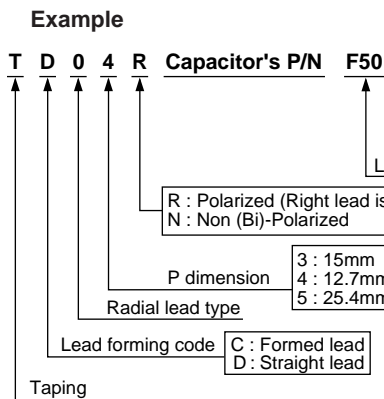

QUANTITY PER AMMO PACK

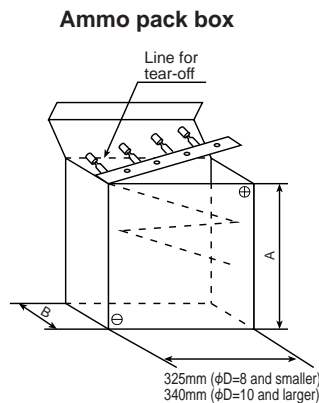

Typical example

Case size φD × L (mm)	A (mm)	B (mm)	Quantity (pcs.)
φ3	210	45	3,000
φ3.5	230	45	3,000
φ4	L=5 to 9mm	186	45
	L=11.5mm	190	54
φ5	L=5 & 7mm	218	54
	L=9 to 17mm	236	54
φ6.3	L=5 & 7mm	282	45
	L=9 to 17mm	284	54
φ7	L=5 & 7mm	174	45
	L=9 to 17mm	236	45
φ8	L=9 to 17mm	236	54
	L=20 to 22mm	236	62
φ10	L=9 to 25mm	308	62
	L=30 to 40mm	308	67
φ12.5	308	67	500

The following lead configurations are available upon request. When ordering, please indicate the type of lead configurations by using the appropriate supplement code, such as C5, FC, MC or RC in the product part number.

[mm]

●Lead Configuration : C5

$\phi D=3$ to 18

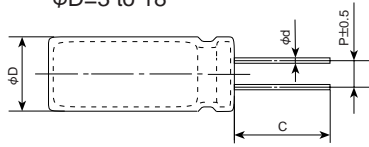

Case diameter C:Lead length

$\phi D=3$ to 8 : 5.0 ± 0.5

$\phi D=10$ to 18 : $5.0^{+1.0}_{-0}$

●Lead Configuration : C3.5

$\phi D=3$ to 18

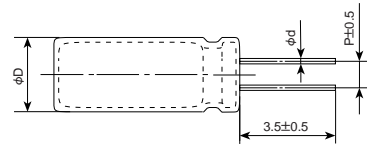

●Lead Configuration : FC

$\phi D=5$ to 8

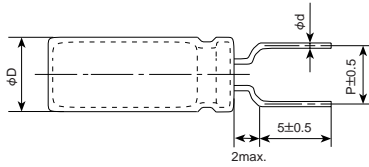

●Lead Configuration : FM

$\phi D=5$ to 8

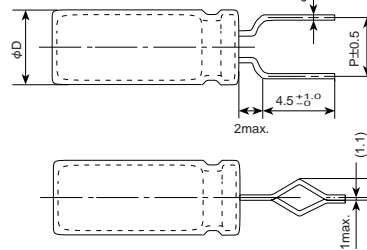

●Lead Configuration : MC

$\phi D=10$ to 18

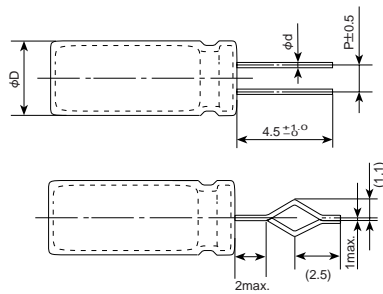

●Lead Configuration : RC

$\phi D=20$ & 22

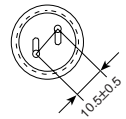
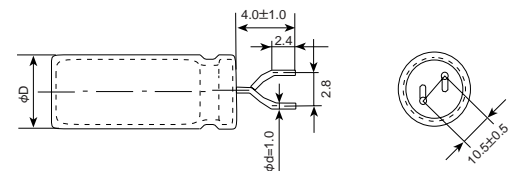

NP-CAP-®-PX RECOMMENDED REFLOW SOLDERING CONDITIONS

The following conditions are recommended for air or infrared reflow soldering PXseries onto a glass epoxy circuit board of 90×50×0.8mm (with resist) by cream solder (eutectic solder). The temperatures shown are the surface temperature values on the top of the can.

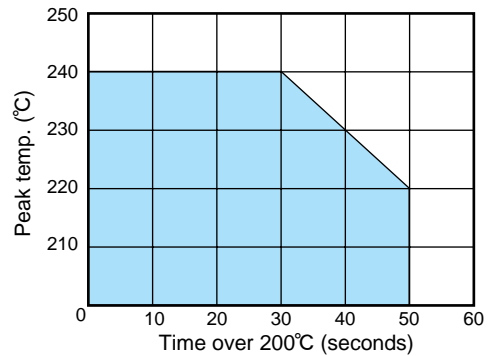
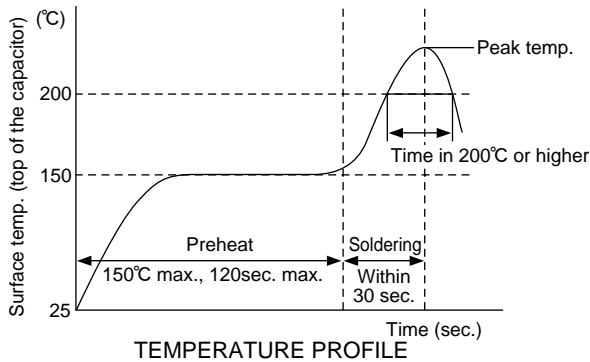

●Recommended Solder Land on PC Board

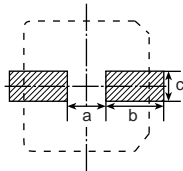
VC

Case code	a	b	c
F60	1.9	3.5	1.6
H70	3.1	4.2	2.2
J80	4.5	4.4	2.2

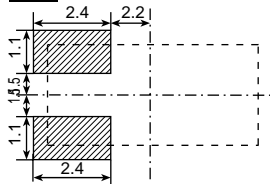
FC

Solder land on PC board

◆PRECAUTIONS FOR USERS

Soldering method

The capacitors of NP-CAP-PX series have no capability to withstand such dip or wave soldering as totally immersing components into a solder bath.

Reflow soldering

Reflow the capacitors within Recommended Reflow Soldering Conditions. Verify no temperature stress to the capacitors because the following differences might degrade capacitors electrically and mechanically. Please consult us if other reflow conditions are employed.

1. Location of components ; Temperature increases at the edge of PC board more than the center.
2. Population of PC board ; The less the component population is, the more temperature rises.
3. Material of PC board ; A ceramic-made board needs more heat than a glass epoxy-made board. The heat increase may cause damage of the capacitors.
4. Thickness of PC board ; A thicker board needs heat than a thinner board. The heat may damage the capacitors.
5. Size of PC board ; A larger board needs heat than a smaller board. The heat may damage the capacitors.
6. Location of infrared ray lamps ; IR reflow as well as hot plate reflow applies heat only on the reverse side of the PC board to lessen heat stress to the capacitors.

Rework of soldering

Avoid reflow soldering more than once. Use a soldering iron for rework. Do not exceed an iron tip temperature of 300°C and an exposure time of 5 seconds.

Mechanical stress

Do not grab the capacitors to lift the PC board and give stress to the

capacitor. Avoid bending the PC board. These may damage the capacitors.

Cleaning assembly board

Immediately after solvent cleaning, remove residual solvent for at least 10 minutes with an air knife. The solvent is so insufficiently dry that the capacitors may be corroded.

Coating on assembly board

1. Before curing coating material, remove the cleaning solvents from the assembly board.
2. Before conformal coating, a chloride free pre-coat material is recommended to use for lessening stress to the capacitors.

Molding with resin

Internal chemical reaction gradually produces gas in the capacitor; then, internal pressure is increasing. If the end seal of the capacitor is completely molded with a resin, the gas stays inside the capacitor. It will face dangerous situation. The chlorine in resin will penetrate into the end seal, reach the inside element, and cause damage of the capacitor.

Glue

Glue is recommended to fix the FC type without dummy terminal on PC board. The followings are requirements of glue.

1. A low curing temperature for short period of time
2. Strong adhesion and heat resistance after curing
3. Long shelf life
4. No corrosion

Others

Precautions for users for Aluminum Electrolytic Capacitors shall be referred.

RECOMMENDED REFLOW SOLDERING CONDITION

Alchip® MX/MFZ/MFX Series

The following conditions are recommended for air or infrared reflow soldering of the surface mount capacitors onto a glass epoxy circuit board of 90×50×0.8mm (with resist) by cream solder (eutectic solder). The temperatures shown are the surface temperature values on the top of the cap.

- Hot plate reflow
- Infrared reflow

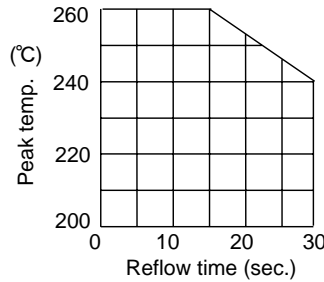
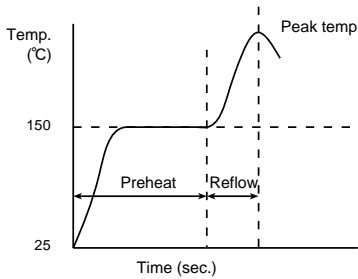

preheat : 150°C max. within 120 seconds

● Recommended Solder Land on PC Board

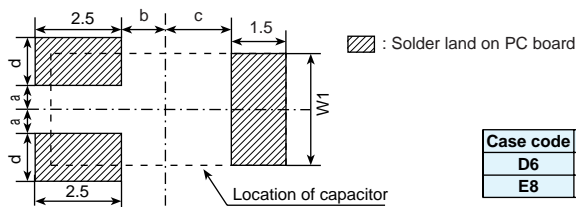

	[mm]				
Case code	a	b	c	d	W1
D6	0.8	1.15	1.7	1.7	4.6
E8	0.95	2.15	2.7	2.1	5.7

◆ PRECAUTIONS FOR USERS

Failure mode

1. MX, MFX and MFZ series contain a solid electrolyte, MnO₂ (Manganese Dioxide) ; therefore, the life ends mostly due to random failure mode, mainly short circuit. The failure rate specified in the catalogue will vary by applying voltage and the ambient temperature. Designing device circuit needs to consider the failure rate under your condition.
2. Continuously a large amount of current through a capacitor results in short circuit of the capacitors. The capacitor is overheated at a higher than 500°C. The heat incurs damage of PC board. The current through capacitor is restricted to less than 5A.

Applying voltage

1. Do not apply an over-voltage exceeding the full rated operating voltage of capacitors. The over-voltage may cause increasing the leakage current and giving short circuit.
2. Reducing an applying voltage minimizes a failure rate. For instance, 50% of the full rated operating voltage can reduce failure rate at one hundredth.

Operating temperature

By applying less-full operating voltage to MX at maximum 125°C and MFZ / MFX at maximum 105°C, the capacitor exhibits stable characteristics. The temperature as well as the applying voltage is related to the failure rate. For instance, operating at maximum 60°C can reduce to approximately 1/4 failure rate.

Reverse voltage

MX, MFZ and MFX are polarized capacitors. Do not use the capacitors in wrong polarity. Both series still show stable characteristics even if the reverse voltage up to 15% of the rated voltage at 85°C, or 15% of the maximum operating voltage at 105°C is applied for 250 hours (for MX, 15% of the rated voltage at 125°C). However, this characteristics is not assured for a long period of time.

Permissible ripple current

1. Do not exceed the rated permissible ripple current of the capacitors.
2. The sum of the DC bias voltage and AC voltage must not exceed the specified full rated or maximum operating voltage of the capacitors.

Reflow soldering

High soldering temperature and long soldering time will affect the characteristics of the capacitors. Use reflow soldering conditions within the recommended range. Also, the temperature varies with the location

and population of the components, the material and the thickness of PC board.

Verify temperature profiles prior to actual production run ; then, set reflow condition within the limits prescribed in the catalogue.

MX, MFZ and MFX series might have a high leakage current, a few to 100µA, after reflow soldering. However, the applying voltage to the capacitors gradually decreases the leakage current because of dielectric stabilizing.

Cleaning conditions

As long as the cleaning agents prescribed are used, the cleaning does not give the capacitor any damages. For CFCs substitutions and other cleaning agents, consult us before actual use.

For ultrasonic cleaning, take a pretest under the customer's condition and verify that the condition cannot incur breaking terminals due to vibration.

Storage

Storage MX, MFZ and MFX without no mechanical stress to the capacitors. The storage maintains dry and low temperature, approximately 20°C, to prevent the leads and the dummy terminal from degrading.

Dummy terminal

The purpose of the dummy terminal is to prevent the capacitor body from sliding or lifting up on PC board during reflow soldering. The dummy terminal may be peeled off by the following mechanical stress.

1. Mechanical shock by bending or cutting a multi-board
2. Transportation shock
3. Mechanical stress like lifting up, poking or hitting

Terminal strength

Terminal strength is specified 10N maximum from the side for 5seconds without loosening or cutting off terminals. Do not apply any excessive force to the side of a capacitor soldered on a PC board.

NP CAP™ - **PX** Series

- A new conducting functional polymer is employed as electrolyte
- For digital equipment
- 4 to 25V_{dc}
- High heat reflow capability & solvent-proof type
- Solder land pad is the same as conventional electrolytics



◆ **SPECIFICATIONS**

Items	Characteristics										
Category											
Temperature Range	-55 to +105°C										
Rated Voltage Range	4 to 25V _{dc}										
Capacitance Tolerance	±20% (M) (at 20°C, 120Hz)										
Surge Voltage	Rated voltage×1.15 (V) (at 105°C)										
Leakage Current	I=0.2CV (max.) Where, I : Max. leakage current (μA), C : Nominal capacitance (μF), V : Rated voltage (V) (at 20°C after 2 minutes)										
Dissipation Factor (tanδ)	0.12max. (at 20°C, 120Hz)										
Low Temperature Characteristics (Max. Impedance Ratio)	Z(-25°C)/Z(+20°C) ≤ 1.15 Z(-55°C)/Z(+20°C) ≤ 1.25 (at 100kHz)										
Endurance	The following specifications shall be satisfied when the capacitors are restored to 20°C after the rated voltage is applied for 2000 hours at 105°C. <table border="1"> <tr><td>Appearance</td><td>No significant damage</td></tr> <tr><td>Capacitance change</td><td>≤ ±20% of the initial value</td></tr> <tr><td>DF (tanδ)</td><td>≤ 150% of the initial specified value</td></tr> <tr><td>ESR</td><td>≤ 150% of the initial specified value</td></tr> <tr><td>Leakage current</td><td>≤ The initial specified value</td></tr> </table>	Appearance	No significant damage	Capacitance change	≤ ±20% of the initial value	DF (tanδ)	≤ 150% of the initial specified value	ESR	≤ 150% of the initial specified value	Leakage current	≤ The initial specified value
Appearance	No significant damage										
Capacitance change	≤ ±20% of the initial value										
DF (tanδ)	≤ 150% of the initial specified value										
ESR	≤ 150% of the initial specified value										
Leakage current	≤ The initial specified value										
Bias Humidity	The following specifications shall be satisfied when the capacitors are restored to 20°C after subjecting them to the DC rated voltage at 60°C, 90 to 95% RH for 500 hours. <table border="1"> <tr><td>Appearance</td><td>No significant damage</td></tr> <tr><td>Capacitance change</td><td>≤ ±20% of the initial value</td></tr> <tr><td>DF (tanδ)</td><td>≤ 150% of the initial specified value</td></tr> <tr><td>ESR</td><td>≤ 150% of the initial specified value</td></tr> <tr><td>Leakage current</td><td>≤ The initial specified value</td></tr> </table>	Appearance	No significant damage	Capacitance change	≤ ±20% of the initial value	DF (tanδ)	≤ 150% of the initial specified value	ESR	≤ 150% of the initial specified value	Leakage current	≤ The initial specified value
Appearance	No significant damage										
Capacitance change	≤ ±20% of the initial value										
DF (tanδ)	≤ 150% of the initial specified value										
ESR	≤ 150% of the initial specified value										
Leakage current	≤ The initial specified value										
Surge Voltage	The capacitors shall be subjected to 1000 cycles each consisting of charge with the surge voltage specified at 105°C for 30 seconds through a protective resistor (R=1kΩ) and discharge for 5 minutes 30 seconds. <table border="1"> <tr><td>Appearance</td><td>No significant damage</td></tr> <tr><td>Capacitance change</td><td>≤ ±20% of the initial value</td></tr> <tr><td>DF (tanδ)</td><td>≤ 150% of the initial specified value</td></tr> <tr><td>ESR</td><td>≤ 150% of the initial specified value</td></tr> <tr><td>Leakage current</td><td>≤ The initial specified value</td></tr> </table>	Appearance	No significant damage	Capacitance change	≤ ±20% of the initial value	DF (tanδ)	≤ 150% of the initial specified value	ESR	≤ 150% of the initial specified value	Leakage current	≤ The initial specified value
Appearance	No significant damage										
Capacitance change	≤ ±20% of the initial value										
DF (tanδ)	≤ 150% of the initial specified value										
ESR	≤ 150% of the initial specified value										
Leakage current	≤ The initial specified value										
Failure Rate	1% per 1000 hours maximum (Confidence level 60% at 105°C)										

◆ **DIMENSIONS [mm]**

● Terminal Type : VC

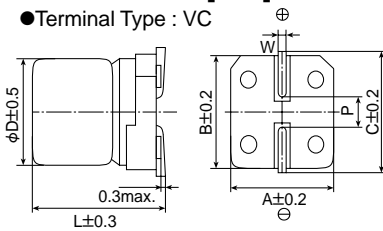

Case code	φD	L	A	B	C	W	P
F60	6.3	5.7	6.6	6.6	7.2	0.5 to 0.8	1.9
H70	8	6.7	8.3	8.3	9.0	0.7 to 1.1	3.1
J80	10	7.7	10.3	10.3	11.0	0.7 to 1.1	4.5

● Terminal Type : FC

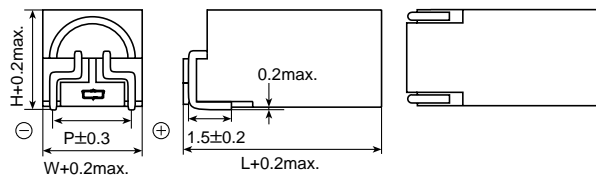

Case code	L	W	H	P
D8	8.3	4.6	4.5	4.0

◆ **MARKING**

VC Type
EX) PX16VC39M



◆ **PART NUMBERING SYSTEM**

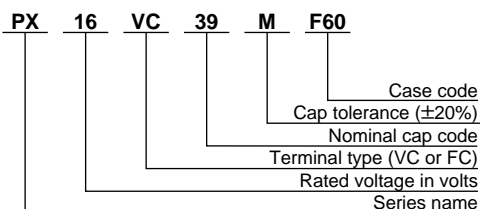

Capacitance	Code
6.8μF	6R8
10μF	10
33μF	33
100μF	100



NP CAP™-PX Series

◆ **STANDARD RATINGS**

● Terminal Type : VC

Case code	Rated voltage (V _{dc})	Capacitance (μF)	ESR (mΩ _{max.} /20°C, 100kHz)	Rated ripple current (mA _{rms} /100k to 300kHz)		Part number
				-55 to +85°C	+85°C to +105°C	
F60	4	100	40	1,550	1,550	PX4VC100MF60
		150	40	1,550	1,550	PX4VC150MF60
	6.3	82	40	1,500	1,500	PX6.3VC82MF60
		100	40	1,550	1,550	PX6.3VC100MF60
	10	56	50	1,450	1,450	PX10VC56MF60
	16	39	60	1,400	1,400	PX16VC39MF60
	20	22	65	1,350	1,350	PX20VC22MF60
27		65	1,350	1,350	PX20VC27MF60	
H70	4	220	35	2,400	2,000	PX4VC220MH70
		330	35	2,400	2,000	PX4VC330MH70
	6.3	150	35	2,200	1,900	PX6.3VC150MH70
		220	35	2,200	1,900	PX6.3VC220MH70
	10	120	40	2,000	1,800	PX10VC120MH70
		150	40	2,000	1,800	PX10VC150MH70
	16	82	45	1,800	1,600	PX16VC82MH70
20	39	50	1,500	1,400	PX20VC39MH70	
J80	4	470	25	3,500	2,500	PX4VC470MJ80
		680	25	3,500	2,500	PX4VC680MJ80
	6.3	330	25	3,100	2,400	PX6.3VC330MJ80
		470	25	3,100	2,400	PX6.3VC470MJ80
	10	270	30	2,800	2,300	PX10VC270MJ80
		330	30	2,800	2,300	PX10VC330MJ80
	16	150	35	2,500	2,000	PX16VC150MJ80
180		35	2,500	2,000	PX16VC180MJ80	
20	82	40	2,000	1,600	PX20VC82MJ80	

● Terminal Type : FC

Case code	Rated voltage (V _{dc})	Capacitance (μF)	ESR (mΩ _{max.} /20°C, 100kHz)	Rated ripple current (mA _{rms} /100k to 300kHz)		Part number
				-55 to +85°C	+85°C to +105°C	
D8	4	47	80	1,000	1,000	PX4FC47MD8
		68	80	1,000	1,000	PX4FC68MD8
	6.3	33	80	1,000	1,000	PX6.3FC33MD8
		39	80	1,000	1,000	PX6.3FC39MD8
	10	22	100	1,000	1,000	PX10FC22MD8
		33	100	1,000	1,000	PX10FC33MD8
	16	15	120	800	800	PX16FC15MD8
25	6.8	150	720	720	PX25FC6R8MD8	

Sub standard

◆ **CASE CODE**

μF \ V _{dc}	4V	6.3V	10V	16V	20V	25V
6.8						D8
8.2						
10						
15				D8		F60
22			D8		F60	
27					F60	
33		D8	D8			
39		D8		F60	H70	
47	D8					
56			F60			
68	D8					
82		F60		H70	J80	
100	F60	F60				
120			H70			
150	F60	H70	H70	J80		
180				J80		
220	H70	H70				
270			J80			
330	H70	J80	J80			
390						
470	J80	J80				
560						
680	J80					

Sub standard

New! Alchip®-MX Series

- 125°C SMT Aluminum Solid Electrolyte Capacitors
- Manganese dioxide is employed as electrolyte
- High heat reflow capability
- Solvent-proof type, see page 16



◆ SPECIFICATIONS

Items	Characteristics										
Category											
Temperature Range	-55 to +125°C										
Rated Voltage Range	4 to 16V _{dc}										
Capacitance Tolerance	±20% (M) (at 20°C, 120Hz)										
Surge Voltage	Rated voltage×1.15 (V)										
Leakage Current	I=0.1CV Where, I : Max. leakage current (μA), C : Nominal capacitance (μF), V : Rated voltage (V) (at 20°C after 2 minutes)										
Dissipation Factor (tanδ)	0.12max. (at 20°C, 120Hz)										
Low Temperature Characteristics	Z(-25°C)/Z(+20°C)≤1.5 Z(-55°C)/Z(+20°C)≤2.0 (at 500kHz)										
Endurance	The following specifications shall be satisfied after the capacitors are subjected to DC voltage at 125°C for 2000 hours with the rated ripple current applied. <table border="1"> <tr> <td>Appearance</td> <td>No significant damage</td> </tr> <tr> <td>Capacitance change</td> <td>≤±20% of the initial value</td> </tr> <tr> <td>DF (tanδ)</td> <td>≤200% of the initial specified value</td> </tr> <tr> <td>ESR</td> <td>≤200% of the initial specified value*</td> </tr> <tr> <td>Leakage current</td> <td>≤The initial specified value</td> </tr> </table> <p>* : 300% for MX16FD6R8MD6</p>	Appearance	No significant damage	Capacitance change	≤±20% of the initial value	DF (tanδ)	≤200% of the initial specified value	ESR	≤200% of the initial specified value*	Leakage current	≤The initial specified value
Appearance	No significant damage										
Capacitance change	≤±20% of the initial value										
DF (tanδ)	≤200% of the initial specified value										
ESR	≤200% of the initial specified value*										
Leakage current	≤The initial specified value										
Bias Humidity	The following specifications shall be satisfied when the capacitors are restored to 20°C after subjecting them to the DC rated voltage at 60°C, 90 to 95% RH for 500 hours. <table border="1"> <tr> <td>Appearance</td> <td>No significant damage</td> </tr> <tr> <td>Capacitance change</td> <td>≤±10% of the initial value</td> </tr> <tr> <td>DF (tanδ)</td> <td>≤150% of the initial specified value</td> </tr> <tr> <td>ESR</td> <td>≤150% of the initial specified value</td> </tr> <tr> <td>Leakage current</td> <td>≤The initial specified value</td> </tr> </table>	Appearance	No significant damage	Capacitance change	≤±10% of the initial value	DF (tanδ)	≤150% of the initial specified value	ESR	≤150% of the initial specified value	Leakage current	≤The initial specified value
Appearance	No significant damage										
Capacitance change	≤±10% of the initial value										
DF (tanδ)	≤150% of the initial specified value										
ESR	≤150% of the initial specified value										
Leakage current	≤The initial specified value										
Surge Voltage Test	The capacitors shall be subjected to 1000 cycles to charge the surge voltage specified at 125°C for 30 seconds through a protective resistor (R=1kΩ), then discharge for 5-1/2 minutes through a resistor with the same value. <table border="1"> <tr> <td>Appearance</td> <td>No significant damage</td> </tr> <tr> <td>Capacitance change</td> <td>≤±5% of the initial value</td> </tr> <tr> <td>DF (tanδ)</td> <td>≤The initial specified value</td> </tr> <tr> <td>ESR</td> <td>≤The initial specified value</td> </tr> <tr> <td>Leakage current</td> <td>≤The initial specified value</td> </tr> </table>	Appearance	No significant damage	Capacitance change	≤±5% of the initial value	DF (tanδ)	≤The initial specified value	ESR	≤The initial specified value	Leakage current	≤The initial specified value
Appearance	No significant damage										
Capacitance change	≤±5% of the initial value										
DF (tanδ)	≤The initial specified value										
ESR	≤The initial specified value										
Leakage current	≤The initial specified value										
Reverse Voltage	The capacitors shall be subjected to 15% of the rated voltage at 125°C, in the reverse polarity direction for 125 hours, and shall be subjected to the rated voltage at 125°C, in the forward polarity direction for 125 hours. <table border="1"> <tr> <td>Appearance</td> <td>No significant damage</td> </tr> <tr> <td>Capacitance change</td> <td>≤±10% of the initial value</td> </tr> <tr> <td>DF (tanδ)</td> <td>≤The initial specified value</td> </tr> <tr> <td>ESR</td> <td>≤The initial specified value</td> </tr> <tr> <td>Leakage current</td> <td>≤The initial specified value</td> </tr> </table>	Appearance	No significant damage	Capacitance change	≤±10% of the initial value	DF (tanδ)	≤The initial specified value	ESR	≤The initial specified value	Leakage current	≤The initial specified value
Appearance	No significant damage										
Capacitance change	≤±10% of the initial value										
DF (tanδ)	≤The initial specified value										
ESR	≤The initial specified value										
Leakage current	≤The initial specified value										
Thermal Shock	After the capacitors are subjected to -55°C for 30 minutes and +125°C for 30 minutes for 5 cycles, they shall be conducted in accordance with the endurance test or the bias humidity test specified above.										
Failure Rate	1% per 1000 hours maximum (Confidence level 60% at 105°C)										
Others	IEC 384-18-1 (Fixed Aluminum Electrolytic Chip Capacitors with Solid Electrolyte)										

◆ DIMENSIONS (Terminal Type=FD) [mm]

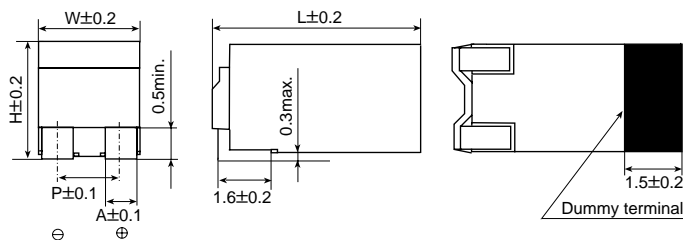

Case code	L	W	H	P	A
D6	6.4	4.6	4.6	3.3	1.1
E8	8.4	5.7	5.7	4.0	1.5

◆ PART NUMBERING SYSTEM

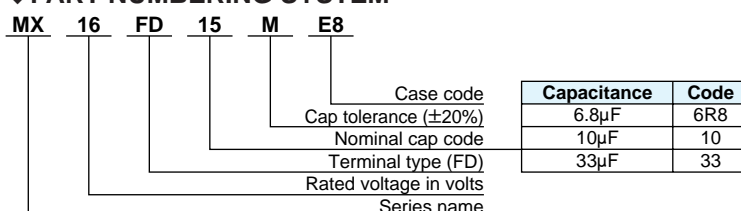

◆ **STANDARD RATINGS**

Rated voltage (V _{dc})	Capacitance (μF)	Case code	ESR (mΩ) [20°C/500kHz]	Temperature (°C)	Rated ripple current (mA _{rms})		
					Frequency		
					500kHz	300kHz	100kHz
4	27	D6	270	125	320	300	270
				105	500	480	440
				85	570	540	490
				60	660	630	570
	56	E8	180	125	390	370	350
				105	580	550	530
				85	700	660	630
				60	810	770	740
6.3	22	D6	270	125	320	300	270
				105	500	480	440
				85	570	540	490
				60	660	630	570
	47	E8	180	125	390	370	350
				105	580	550	530
				85	700	660	630
				60	810	770	740
10	15	D6	270	125	320	300	270
				105	500	480	440
				85	570	540	490
				60	660	630	570
	33	E8	180	125	390	370	350
				105	580	550	530
				85	700	660	630
				60	810	770	740
16	6.8	D6	425	125	130	110	100
				105	190	170	150
				85	220	200	180
				60	250	230	200
	15	E8	270	125	320	300	270
				105	500	480	440
				85	570	540	490
				60	660	630	570

Alchip® MFZ/MFX Series

- Manganese dioxide is employed as electrolyte
- For digital equipment
- High heat reflow capability
- Solvent-proof type, see page 16

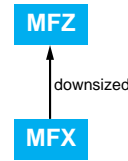

◆ SPECIFICATIONS

Items	Characteristics										
Category Temperature Range	-55 to +105°C										
Rated Voltage Range	4 to 20V _{dc} ±20% of the initial value (For the maximum operating voltage at 105°C, see STANDARD RATINGS)										
Capacitance Tolerance	±20% (M) (at 20°C, 120Hz)										
Surge Voltage	105°C : (value at 105°C in STANDARD RATINGS) × 1.15 85°C and below : Rated voltage × 1.15 (V)										
Leakage Current	I = 0.1CV Where, I : Max. leakage current (μA), C : Nominal capacitance (μF), V : Rated voltage (V) (at 20°C after 2 minutes)										
Dissipation Factor (tanδ)	0.12max. (at 20°C, 120Hz)										
Low Temperature Characteristics	Z(-25°C)/Z(+20°C) ≤ 1.5 Z(-55°C)/Z(+20°C) ≤ 2.0 (at 500kHz)										
Endurance	The following specifications shall be satisfied after the capacitors are subjected to DC voltage at 85°C or 105°C for 1000 hours with the specified rated ripple current applied. <table border="1"> <tr><td>Appearance</td><td>No significant damage</td></tr> <tr><td>Capacitance change</td><td>≤ ±10% of the initial value</td></tr> <tr><td>DF (tanδ)</td><td>≤ 150% of the initial specified value</td></tr> <tr><td>ESR</td><td>≤ 150% of the initial specified value</td></tr> <tr><td>Leakage current</td><td>≤ The initial specified value</td></tr> </table>	Appearance	No significant damage	Capacitance change	≤ ±10% of the initial value	DF (tanδ)	≤ 150% of the initial specified value	ESR	≤ 150% of the initial specified value	Leakage current	≤ The initial specified value
Appearance	No significant damage										
Capacitance change	≤ ±10% of the initial value										
DF (tanδ)	≤ 150% of the initial specified value										
ESR	≤ 150% of the initial specified value										
Leakage current	≤ The initial specified value										
Bias Humidity	The following specifications shall be satisfied when the capacitors are restored to 20°C after subjecting them to the DC rated voltage at 60°C, 90 to 95% RH for 500 hours. <table border="1"> <tr><td>Appearance</td><td>No significant damage</td></tr> <tr><td>Capacitance change</td><td>≤ ±10% of the initial value</td></tr> <tr><td>DF (tanδ)</td><td>≤ 150% of the initial specified value</td></tr> <tr><td>ESR</td><td>≤ 150% of the initial specified value</td></tr> <tr><td>Leakage current</td><td>≤ The initial specified value</td></tr> </table>	Appearance	No significant damage	Capacitance change	≤ ±10% of the initial value	DF (tanδ)	≤ 150% of the initial specified value	ESR	≤ 150% of the initial specified value	Leakage current	≤ The initial specified value
Appearance	No significant damage										
Capacitance change	≤ ±10% of the initial value										
DF (tanδ)	≤ 150% of the initial specified value										
ESR	≤ 150% of the initial specified value										
Leakage current	≤ The initial specified value										
Surge Voltage Test	The capacitors shall be subjected to 1000 cycles to charge the surge voltage specified at 85°C or 105°C for 30 seconds through a protective resistor (R=1kΩ), then discharge for 5-1/2 minutes through a resistor with the same value. <table border="1"> <tr><td>Appearance</td><td>No significant damage</td></tr> <tr><td>Capacitance change</td><td>≤ ±5% of the initial value</td></tr> <tr><td>DF (tanδ)</td><td>≤ The initial specified value</td></tr> <tr><td>ESR</td><td>≤ 150% of the initial specified value</td></tr> <tr><td>Leakage current</td><td>≤ The initial specified value</td></tr> </table>	Appearance	No significant damage	Capacitance change	≤ ±5% of the initial value	DF (tanδ)	≤ The initial specified value	ESR	≤ 150% of the initial specified value	Leakage current	≤ The initial specified value
Appearance	No significant damage										
Capacitance change	≤ ±5% of the initial value										
DF (tanδ)	≤ The initial specified value										
ESR	≤ 150% of the initial specified value										
Leakage current	≤ The initial specified value										
Reverse Voltage	The capacitors shall be subjected to 15% of the rated voltage at 85°C, or 15% of the maximum operating voltage at 105°C, in the reverse polarity direction for 125 hours, and shall be subjected to the rated voltage at 85°C, or the maximum operating voltage at 105°C, in the forward polarity direction for 125 hours. <table border="1"> <tr><td>Appearance</td><td>No significant damage</td></tr> <tr><td>Capacitance change</td><td>≤ ±10% of the initial value</td></tr> <tr><td>DF (tanδ)</td><td>≤ The initial specified value</td></tr> <tr><td>ESR</td><td>≤ The initial specified value</td></tr> <tr><td>Leakage current</td><td>≤ The initial specified value</td></tr> </table>	Appearance	No significant damage	Capacitance change	≤ ±10% of the initial value	DF (tanδ)	≤ The initial specified value	ESR	≤ The initial specified value	Leakage current	≤ The initial specified value
Appearance	No significant damage										
Capacitance change	≤ ±10% of the initial value										
DF (tanδ)	≤ The initial specified value										
ESR	≤ The initial specified value										
Leakage current	≤ The initial specified value										
Thermal Shock	After the capacitors are subjected to -55°C, for 30 minutes and +125°C for 30 minutes for 5 cycles, they shall be conducted in accordance with the endurance test or the bias humidity test specified above.										
Failure Rate	1% per 1000 hours maximum (Confidence level 60% at 105°C)										
Others	IEC 384-18-1 (Fixed Aluminum Electrolytic Chip Capacitors with Solid Electrolyte)										

◆ DIMENSIONS (Terminal Type=FD) [mm]

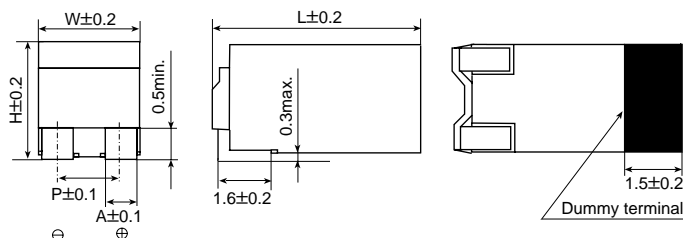

Case code	L	W	H	P	A
D6	6.4	4.6	4.6	3.3	1.1
E8	8.4	5.7	5.7	4.0	1.5

◆ PART NUMBERING SYSTEM

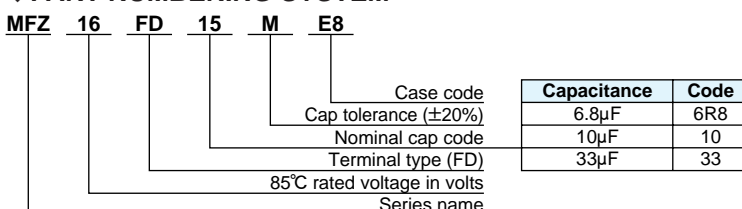

Alchip® **MFZ/MFX** Series

◆STANDARD RATINGS

MFZ

Case code	Rated voltage (V _{dc})	Cap (μF)	ESR (mΩ) [20°C/500kHz]	Temp. (°C)	Max operating voltage (V _{dc})	Rated ripple (mA _{rms})			Case code	Rated voltage (V _{dc})	Cap (μF)	ESR (mΩ) [20°C/500kHz]	Temp. (°C)	Max operating voltage (V _{dc})	Rated ripple (mA _{rms})		
						500kHz	300kHz	100kHz							500kHz	300kHz	100kHz
D6	4	27	270	105	3.2	320	300	270	E8	4	56	180	105	3.2	390	370	350
				85	4	500	480	440					85	4	580	550	530
				60	4	570	540	490					60	4	700	660	630
				45	4	660	630	570					45	4	810	770	740
	6.3	22	270	105	5	320	300	270		105	5	390	370	350			
				85	6.3	500	480	440		85	6.3	580	550	530			
				60	6.3	570	540	490		60	6.3	700	660	630			
				45	6.3	660	630	570		45	6.3	810	770	740			
	10	15	270	105	8	320	300	270		105	8	390	370	350			
				85	10	500	480	440		85	10	580	550	530			
				60	10	570	540	490		60	10	700	660	630			
				45	10	660	630	570		45	10	810	770	740			
	16	6.8	425	105	13	130	110	100		105	13	320	300	270			
				85	16	190	170	150		85	16	500	480	440			
				60	16	220	200	180		60	16	570	540	490			
				45	16	250	230	200		45	16	660	630	570			
				105	16	320	300	270	105	16	390	370	350				
				85	20	500	480	440	85	20	580	550	530				
				60	20	570	540	490	60	20	700	660	630				
				45	20	660	630	570	45	20	810	770	740				

MFX

Case code	Rated voltage (V _{dc})	Cap (μF)	ESR (mΩ) [20°C/500kHz]	Temp. (°C)	Max operating voltage (V _{dc})	Rated ripple (mA _{rms})			Case code	Rated voltage (V _{dc})	Cap (μF)	ESR (mΩ) [20°C/500kHz]	Temp. (°C)	Max operating voltage (V _{dc})	Rated ripple (mA _{rms})		
						500kHz	300kHz	100kHz							500kHz	300kHz	100kHz
D6	4	22	270	105	3.2	320	300	270	E8	4	47	180	105	3.2	390	370	350
				85	4	500	480	440					85	4	580	550	530
				60	4	570	540	490					60	4	700	660	630
				45	4	660	630	570					45	4	810	770	740
	6.3	15	270	105	5	320	300	270		105	5	390	370	350			
				85	6.3	500	480	440		85	6.3	580	550	530			
				60	6.3	570	540	490		60	6.3	700	660	630			
				45	6.3	660	630	570		45	6.3	810	770	740			
	10	10	270	105	8	320	300	270		105	8	390	370	350			
				85	10	500	480	440		85	10	580	550	530			
				60	10	570	540	490		60	10	700	660	630			
				45	10	660	630	570		45	10	810	770	740			
	16	4.7	425	105	13	130	110	100		105	13	320	300	270			
				85	16	190	170	150		85	16	500	480	440			
				60	16	220	200	180		60	16	570	540	490			
				45	16	250	230	200		45	16	660	630	570			

Alchip® MFS/MFA Series

- Downsized from current standard MF series
- 3.5 to 4.5 mm height
- MFS : case code B46 to D46, MFA : case code D80
- Capable of reducing mounting area on PC board

MFS
MFA

↓
downsized
MF



SPECIFICATIONS

Items	Characteristics								
Category	-40 to +85°C								
Temperature Range	-40 to +85°C								
Rated Voltage Range	4 to 35V _{dc}								
Capacitance Tolerance	±20% (M) (at 20°C, 120Hz)								
Leakage Current	I = 0.01CV or 3μA, whichever is greater. (at 20°C after 2 minutes)								
Dissipation Factor (tanδ)	Rated voltage (V _{dc})		4V	6.3V	10V	16V	25V	35V	
	tanδ (Max.)		0.65	0.55	0.45	0.35	0.20	0.18	
Low Temperature Characteristics (Max. Impedance Ratio)	Rated voltage (V _{dc})		4V	6.3V	10V	16V	25V	35V	
	Z(-25°C)/Z(+20°C)	MFS	B46 & C46	9	6	4	3	2	2
		MFA	D80	7	4	3	2	2	2
	Z(-40°C)/Z(+20°C)	MFS	B46 & C46	17	12	9	7	5	4
		MFA	D80	15	10	8	6	4	3
	(at 120Hz)								
Endurance	The following specifications shall be satisfied when the capacitors are restored to 20°C after the rated voltage is applied for 2000 hours (B46 & C46 sizes 1000 hours) at 85°C.								
	Case code	B46 & C46		D46 & D80			D46 & D80		
	Rated Voltage	4 to 35V _{dc}		4 to 6.3V _{dc}			10 to 35V _{dc}		
	Capacitance change	≤±25% of the initial value		≤±30% of the initial value			≤±25% of the initial value		
	DF (tanδ)	≤200% of the initial specified value		≤300% of the initial specified value			≤300% of the initial specified value		
	Leakage current	≤The initial specified value		≤The initial specified value			≤The initial specified value		
Shelf Life	The following specifications shall be satisfied when the capacitors are restored to 20°C after exposing them for 500 hours at 85°C without voltage applied.								
	Capacitance change	≤±20% of the initial value							
	DF (tanδ)	≤200% of the initial specified value							
	Leakage current	≤The initial specified value							

DIMENSIONS (Terminal Type=FC) [mm]

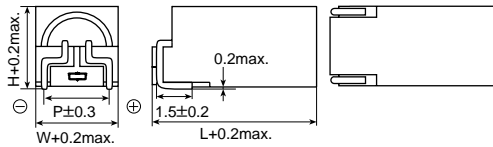

Series	Case code	L	W	H	P
MFS	B46	4.8	3.6	3.5	3.0
	C46	4.8	4.1	4.0	3.5
	D46	4.8	4.6	4.5	4.0
MFA	D80	8.3	4.6	4.5	4.0

MARKING

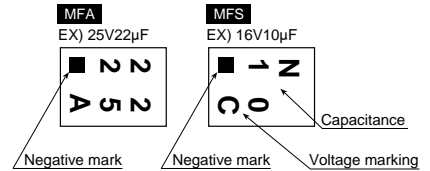

V _{dc}	4	6.3	10	16	25	35
Mark	9	j	A	C	E	V

PART NUMBERING SYSTEM

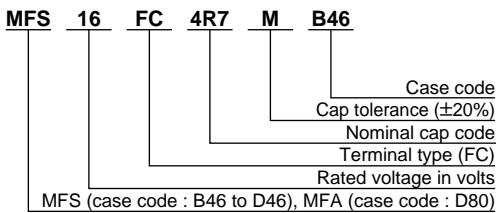

Capacitance	Code
0.1μF	R1
1.0μF	1
4.7μF	4R7
10μF	10
100μF	100

STANDARD RATINGS

represent MFA series

μF	V _{dc}	4	6.3	10	16	25	35
0.1							B46 0.9
0.22							B46 2.0
0.33							B46 2.6
0.47							B46 3.2
1.0							B46 4.6
2.2							B46 6.5
3.3							B46 8.3
4.7				B46 6.0	B46 5.5	B46 7.5	B46 8.3
10	B46	7.5	B46 8.2	B46 8.5	B46 10	D46 15	D80 20
22	B46	11	C46 16	D46 18	D46 20	D80 27	D80 29
33	C46	14	D46 19	D46 20	D80 25	D80 34	
47	D46	21	D46 22	D80 27	D80 35		
100	D80	32	D80 35				

Alchip[®] MF Series

- Wide variety of case sizes (7 sizes)
- Suitable to fit for downsized equipment
- Solvent-proof type, see page 16

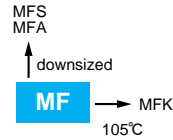

◆SPECIFICATIONS

Items	Characteristics									
Category	Surface Mount Aluminum Electrolytic Capacitor									
Temperature Range	-40 to +85°C									
Rated Voltage Range	4 to 50V _{dc}									
Capacitance Tolerance	±20% (M) (at 20°C, 120Hz)									
Leakage Current	I=0.01CV or 3μA, whichever is greater. (at 20°C after 2 minutes) Where, I : Max. leakage current (μA), C : Nominal capacitance (μF), V : Rated voltage (V)									
Dissipation Factor (tanδ)	See STANDARD RATINGS.									
Low Temperature Characteristics (Max. Impedance Ratio)	Rated voltage (V _{dc})	4V	6.3V	10V	16V	25V	35V	50V		
	Z(-25°C)/Z(+20°C)	A6	10	7	5	4	3	2	2	
		B6 & C6	9	6	4	3	2	2	2	
		D6 to D13	7	4	3	2	2	2	2	
Z(-40°C)/Z(+20°C)	A6	18	13	10	8	6	5	5		
	B6 & C6	17	12	9	7	5	4	4		
	D6 to D13	15	10	8	6	4	3	3	(at 120Hz)	
Endurance	The following specifications shall be satisfied when the capacitors are restored to 20°C after the rated voltage is applied for 2000 hours at 85°C.									
	Case code	A6			B6 & C6			D6 to D13		
	Capacitance change	≤±30% of the initial value			≤±25% of the initial value			≤±20% of the initial value		
	DF (tanδ)	≤200% of the initial specified value			≤200% of the initial specified value			≤200% of the initial specified value		
	Leakage current	≤The initial specified value			≤The initial specified value			≤The initial specified value		
Shelf Life	The following specifications shall be satisfied when the capacitors are restored to 20°C after exposing them for 500 hours at 85°C without voltage applied.									
	Capacitance change	≤±15% of the initial value								
	DF (tanδ)	≤150% of the initial specified value								
	Leakage current	≤The initial specified value								

◆DIMENSIONS (Terminal Type=FC or FD <dummy terminal>) [mm]

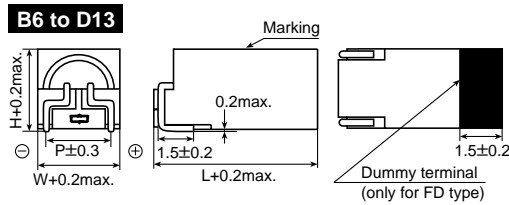
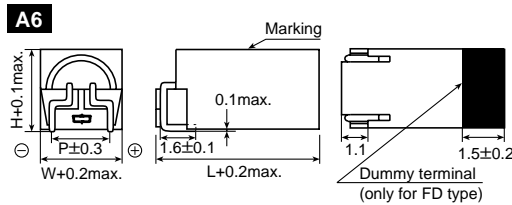

◆MARKING

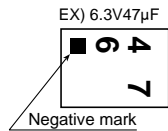

Case code	L	W	H	P
A6	6.3	3.1	3.0	2.4
B6	6.3	3.6	3.5	3.0
C6	6.3	4.1	4.0	3.5
D6	6.3	4.6	4.5	4.0
D8	8.3	4.6	4.5	4.0
D10	10.3	4.6	4.5	4.0
D13	13.3	4.6	4.5	4.0

◆PART NUMBERING SYSTEM

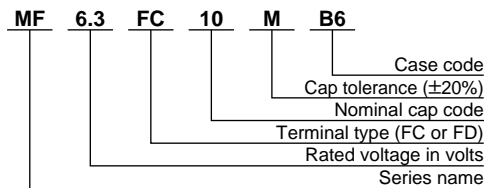

Capacitance	Code
0.1μF	R1
0.47μF	R47
1.0μF	1
4.7μF	4R7
10μF	10
100μF	100

◆STANDARD RATINGS

μF	V _{dc}	4	6.3	10	16	25	35	50	
0.1								A6 0.16 B6 0.14 C6 0.14 D6 0.14	
0.22								A6 0.16 B6 0.14 C6 0.14 D6 0.14	
0.33								A6 0.16 B6 0.14 C6 0.14 D6 0.14	
0.47								A6 0.16 B6 0.14 C6 0.14 D6 0.14	
1.0								A6 0.16 B6 0.14 C6 0.14 D6 0.14	
1.5							A6 0.18 B6 0.18 C6 0.18 D6 0.18	5.3 5.3 5.3 5.3	
2.2							A6 0.18 B6 0.18 C6 0.18 D6 0.18	7.2 7.2 7.2 7.2	
3.3						A6 0.20 B6 0.20 C6 0.20 D6 0.20	8.3 8.3 8.3 8.3	11 11 11 11	
4.7						A6 0.20 B6 0.20 C6 0.20 D6 0.20	9.9 9.9 9.9 9.9	16 16 16 16	
6.8						A6 0.20 B6 0.20 C6 0.20 D6 0.20	13 13 13 13	19 19 19 19	
10			A6 0.55 B6 0.40	8.2 11		B6 0.35 C6 0.24 D6 0.24	12 17 17	D8 0.16 D10 0.16 D13 0.16	22 30 38
15				B6 0.45 C6 0.45 D6 0.45	14 19 24		D8 0.16 D10 0.16 D13 0.16	25 34 51	30 43 51
22									
33									
47	C6 0.65	21	D6 0.55	29	D10 0.28	41	D13 0.24	53	
68	D8 0.50	35	D10 0.32	44	D13 0.28	58			
100	D10 0.50	46	D13 0.32	63					
150	D13 0.50	67							

Note : → Use next higher voltage part.

Alchip® MFK Series

- Wide variety of case sizes (6 sizes)
- Suitable to fit for downsized equipment
- From 3.5mm height
- Solvent-proof type, see page 16

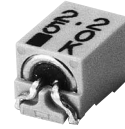
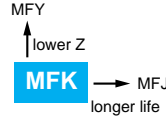

◆SPECIFICATIONS

Items	Characteristics	
Category	Surface Mount	
Temperature Range	-40 to +105°C	
Rated Voltage Range	6.3 to 50V _{dc}	
Capacitance Tolerance	±20% (M) (at 20°C, 120Hz)	
Leakage Current	I=0.01CV or 3μA, whichever is greater. Where, I : Max. leakage current (μA), C : Nominal capacitance (μF), V : Rated voltage (V) (at 20°C after 2 minutes)	
Dissipation Factor (tanδ)	Rated voltage (V _{dc})	6.3V 10V 16V 25V 35V 50V
	tanδ (Max.)	B6 & C6 0.40 0.30 0.24 0.18 0.16 0.14 D6 to D13 0.32 0.28 0.24 0.16 0.14 0.12 (at 20°C, 120Hz)
Low Temperature Characteristics (Max. Impedance Ratio)	Rated voltage (V _{dc})	6.3V 10V 16V 25V 35V 50V
	Z(-25°C)/Z(+20°C)	B6 & C6 6 4 3 2 2 2 D6 to D13 4 3 2 2 2 2
	Z(-40°C)/Z(+20°C)	B6 & C6 12 9 7 5 4 4 D6 to D13 10 8 6 4 3 3 (at 120Hz)
Endurance	The following specifications shall be satisfied when the capacitors are restored to 20°C after the rated voltage is applied for 1000 hours at 105°C.	
	Case code	B6 & C6 D6 to D13
	Capacitance change	≤±30% of the initial value ≤±20% of the initial value
	DF (tanδ)	≤200% of the initial specified value ≤200% of the initial specified value
	Leakage current	≤The initial specified value ≤The initial specified value
Shelf Life	The following specifications shall be satisfied when the capacitors are restored to 20°C after exposing them for 500 hours at 105°C without voltage applied.	
	Case code	B6 & C6 D6 to D13
	Capacitance change	≤±25% of the initial value ≤±15% of the initial value
	DF (tanδ)	≤200% of the initial specified value ≤150% of the initial specified value
	Leakage current	≤The initial specified value ≤The initial specified value

◆DIMENSIONS (Terminal Type=FC or FD <dummy terminal> [mm])

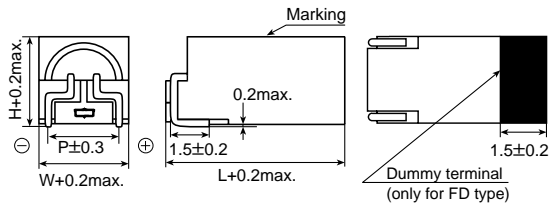

Case code	L	W	H	P
B6	6.3	3.6	3.5	3.0
C6	6.3	4.1	4.0	3.5
D6	6.3	4.6	4.5	4.0
D8	8.3	4.6	4.5	4.0
D10	10.3	4.6	4.5	4.0
D13	13.3	4.6	4.5	4.0

◆MARKING

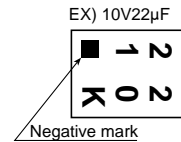

◆PART NUMBERING SYSTEM

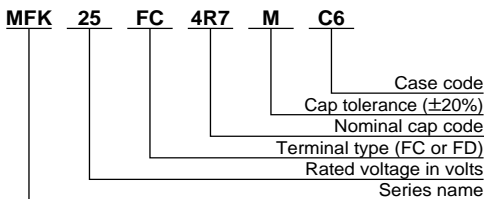

Capacitance	Code
0.1μF	R1
0.47μF	R47
1.0μF	1
4.7μF	4R7
10μF	10
100μF	100

◆STANDARD RATINGS

μF	V _{dc}	6.3		10		16		25		35		50	
0.1												B6	1.3
0.15												B6	2.0
0.22												B6	2.4
0.33												B6	3.0
0.47												B6	3.5
0.68												B6	4.3
1.0												B6	5.2
1.5												B6	6.4
2.2												C6	8.4
3.3												D6	13
4.7												D8	16
6.8												D10	20
10		B6	11	B6	10	C6	12	D6	16	D8	18	D10	26
15		C6	15	D6	19	D8	23	D10	21	D13	30	D13	38
22		D6	20	D8	25	D10	37	D13	51				
33		D8	27										
47				D10	41	D13	53						
68		D10	44	D13	58								
100		D13	63										

Note : → Use next higher voltage part.

Alchip® MFY Series

- Chose 4 case sizes, from 4.5mm height
- Low impedance, 105°C 1000-hour-life
- Solvent-proof type, see page 16



◆ SPECIFICATIONS

Items	Characteristics							
Category	-40 to +105°C							
Temperature Range	-40 to +105°C							
Rated Voltage Range	6.3 to 50V _{dc}							
Capacitance Tolerance	±20% (M) (at 20°C, 120Hz)							
Leakage Current	I = 0.01CV or 3μA, whichever is greater. (at 20°C after 2 minutes)							
	Where, I : Max. leakage current (μA), C : Nominal capacitance (μF), V : Rated voltage (V)							
Dissipation Factor (tanδ)	Rated voltage (V _{dc})	6.3V	10V	16V	25V	35V	50V	(at 20°C, 120Hz)
	tanδ (Max.)	0.24	0.20	0.16	0.14	0.12	0.12	
Low Temperature Characteristics (Max. Impedance Ratio)	Rated voltage (V _{dc})	6.3V	10V	16V	25V	35V	50V	(at 120Hz)
	Z(-25°C)/Z(+20°C)	2	2	2	2	2	2	
	Z(-40°C)/Z(+20°C)	3	3	3	3	3	3	
Endurance	The following specifications shall be satisfied when the capacitors are restored to 20°C after the rated voltage is applied for 1000 hours at 105°C.							
	Rated voltage	6.3V _{dc}			10 to 50V _{dc}			
	Capacitance change	≤±30% of the initial value			≤±20% of the initial value			
	DF (tanδ)	≤300% of the initial specified value			≤200% of the initial specified value			
	Leakage current	≤The initial specified value			≤The initial specified value			
Shelf Life	The following specifications shall be satisfied when the capacitors are restored to 20°C after exposing them for 1000 hours at 105°C without voltage applied.							
	Rated voltage	6.3V _{dc}			10 to 50V _{dc}			
	Capacitance change	≤±30% of the initial value			≤±20% of the initial value			
	DF (tanδ)	≤300% of the initial specified value			≤200% of the initial specified value			
	Leakage current	≤The initial specified value			≤The initial specified value			

◆ DIMENSIONS (Terminal Type=FC or FD <dummy terminal>)[mm]

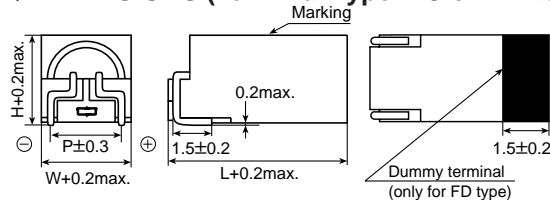

Case code	L	W	H	P
D6	6.3	4.6	4.5	4.0
D8	8.3	4.6	4.5	4.0
D10	10.3	4.6	4.5	4.0
D13	13.3	4.6	4.5	4.0

◆ MARKING

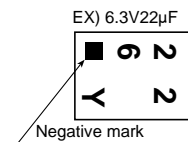

◆ PART NUMBERING SYSTEM

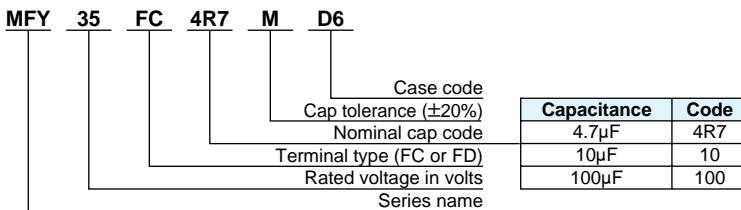

◆ STANDARD RATINGS

V _{dc}	6.3	10	16	25	35	50
3.3	Case code					
4.7	Max. impedance (Ω) at 20°C, 100kHz					
6.8	Rated ripple current (mA) at 105°C, 100kHz					
10	D6 2.8 51		D8 2.4 61		D10 1.3 87	
15	D6 2.8 51		D8 2.4 61		D10 1.3 87	
22	D6	2.8	51	D8	2.4	61
33	D8	2.4	61	D10	1.3	87
47	D10 1.3 87		D13 0.9 133		D13 0.9 133	
68	D10	1.3	87	D13	0.9	133
100	D13	0.9	133			

Note : → Use next higher voltage part.

Alchip® MFJ Series

- Chose 4 case sizes from 4.5mm height
- Endurance : 105°C 2000 hours
- Solvent-proof type, see page 16

MFJ
↑ longer life
MFK

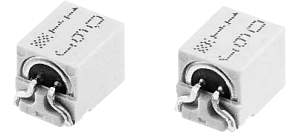

◆ SPECIFICATIONS

Items	Characteristics							
Category	-40 to +105°C							
Temperature Range	-40 to +105°C							
Rated Voltage Range	6.3 to 50V _{dc}							
Capacitance Tolerance	±20% (M) (at 20°C, 120Hz)							
Leakage Current	I = 0.01CV or 3μA, whichever is greater. (at 20°C after 2 minutes) Where, I : Max. leakage current (μA), C : Nominal capacitance (μF), V : Rated voltage (V)							
Dissipation Factor (tan δ)	Rated voltage (V _{dc})	6.3V	10V	16V	25V	35V	50V	(at 20°C, 120Hz)
	tan δ (Max.)	0.32	0.28	0.24	0.16	0.14	0.12	
Low Temperature Characteristics (Max. Impedance Ratio)	Rated voltage (V _{dc})	6.3V	10V	16V	25V	35V	50V	(at 120Hz)
	Z(-25°C)/Z(+20°C)	4	3	2	2	2	2	
	Z(-40°C)/Z(+20°C)	12	8	6	4	3	3	
Endurance	The following specifications shall be satisfied when the capacitors are restored to 20°C after the rated voltage is applied for 2000 hours at 105°C.							
	Rated voltage	6.3V _{dc}			10 & 16V _{dc}		25 to 50V _{dc}	
	Capacitance change	≤±30% of the initial value			≤±25% of the initial value		≤±20% of the initial value	
	DF (tan δ)	≤300% of the initial specified value			≤300% of the initial specified value		≤200% of the initial specified value	
	Leakage current	≤The initial specified value			≤The initial specified value		≤The initial specified value	
Shelf Life	The following specifications shall be satisfied when the capacitors are restored to 20°C after exposing them for 1000 hours at 105°C without voltage applied.							
	Rated voltage	6.3V _{dc}			10 & 16V _{dc}		25 to 50V _{dc}	
	Capacitance change	≤±30% of the initial value			≤±25% of the initial value		≤±20% of the initial value	
	DF (tan δ)	≤300% of the initial specified value			≤300% of the initial specified value		≤200% of the initial specified value	
	Leakage current	≤The initial specified value			≤The initial specified value		≤The initial specified value	

◆ DIMENSIONS (Terminal Type=FC or FD <dummy terminal>) [mm]

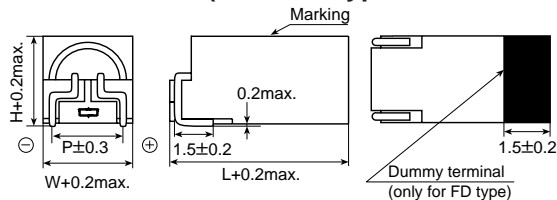

Case code	L	W	H	P
D6	6.3	4.6	4.5	4.0
D8	8.3	4.6	4.5	4.0
D10	10.3	4.6	4.5	4.0
D13	13.3	4.6	4.5	4.0

◆ MARKING

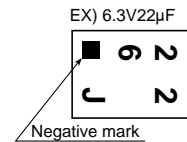

◆ PART NUMBERING SYSTEM

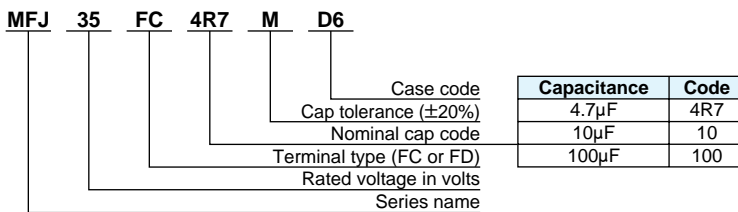

◆ STANDARD RATINGS

μF \ V _{dc}	6.3	10	16	25	35	50
3.3	Case code					
4.7	Rated ripple current (mA _{rms}) at 105°C, 120Hz					
6.8	D6 16 D8 18 D10 20					
10	D6 19 D8 23 D10 26 D13 28					
15	D6 20 D8 25 D10 27 D13 30					
22	D6 27 D8 34 D10 37 D13 43					
33	D6 37 D8 41 D10 44 D13 51					
47	D6 44 D8 47 D10 53 D13 58					
68	D6 53 D8 58 D10 63 D13 70					
100	D6 63 D8 68 D10 75 D13 84					

Note : → Use next higher voltage part.



Alchip® MFK Large Capacitance

- Endurance : 105°C 2000 hours
- Solvent-proof type, see page 16



◆ SPECIFICATIONS

Items	Characteristics						
Category Temperature Range	-40 to +105°C						
Rated Voltage Range	10 to 50V _{dc}						
Capacitance Tolerance	±20% (M) (at 20°C, 120Hz)						
Leakage Current	I = 0.01CV or 3μA, whichever is greater. Where, I : Max. leakage current (μA), C : Nominal capacitance (μF), V : Rated voltage (V) (at 20°C after 2 minutes)						
Dissipation Factor (tanδ)	Rated voltage (V _{dc})	10V	16V	25V	35V	50V	(at 20°C, 120Hz)
	tanδ (Max.)	0.30	0.25	0.22	0.18	0.18	
Low Temperature Characteristics (Max. Impedance Ratio)	Rated voltage (V _{dc})	10V	16V	25V	35V	50V	(at 120Hz)
	Z(-25°C)/Z(+20°C)	3	2	2	2	2	
	Z(-40°C)/Z(+20°C)	8	6	4	3	3	
Endurance	The following specifications shall be satisfied when the capacitors are restored to 20°C after the rated voltage is applied for 2000 hours at 105°C.						
	Capacitance change	≤ ±20% of the initial value					
	DF (tanδ)	≤ 200% of the initial specified value					
	Leakage current	The initial specified value					
Shelf Life	The following specifications shall be satisfied when the capacitors are restored to 20°C after exposing them for 500 hours at 105°C without voltage applied.						
	Capacitance change	≤ ±15% of the initial value					
	DF (tanδ)	≤ 150% of the initial specified value					
	Leakage current	≤ The initial specified value					

◆ DIMENSIONS (Terminal Type=FC) [mm]

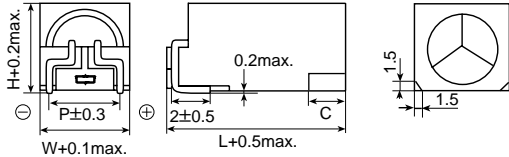

Case code	L	W	H	P	C
H15	17.1	9.0	9.0	7.4	0
H20	21.5	9.0	9.0	7.4	5
H25	26.5	9.0	9.0	7.4	10

◆ MARKING



◆ PART NUMBERING SYSTEM

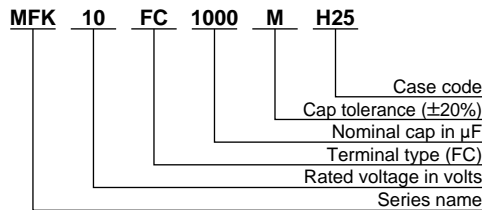

◆ STANDARD RATINGS

μF \ V _{dc}	10		16			25			35			50			
47															
100													H15	0.40	330
180										H15	0.40	330	H15	0.40	330
220										H20	0.27	440	H20	0.27	440
330										H25	0.20	570	H25	0.20	570
470	H15	0.47	330	H15	0.40	330	H20	0.27	440	H20	0.27	440	H25	0.20	570
680	H20	0.27	440	H20	0.27	440	H25	0.20	570						
1,000	H25	0.20	570												

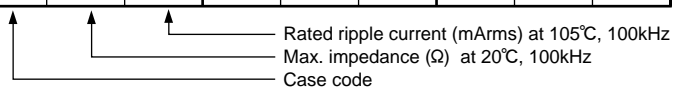

Alchip® MVS Series

- 4.5mm height
- Endurance : 85°C 2000 hours
- Reflow capability
- Solvent-proof type, see page 16

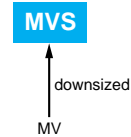

◆ SPECIFICATIONS

Items	Characteristics								
Category Temperature Range	-40 to +85°C								
Rated Voltage Range	4 to 50V _{dc}								
Capacitance Tolerance	±20% (M) (at 20°C, 120Hz)								
Leakage Current	I = 0.01CV or 3μA, whichever is greater. Where, I : Max. leakage current (μA), C : Nominal capacitance (μF), V : Rated voltage (V) (at 20°C after 2 minutes)								
Dissipation Factor (tanδ)	Rated voltage (V _{dc})	4V	6.3V	10V	16V	25V	35V	50V	(at 20°C, 120Hz)
	tanδ (Max.)	0.50	0.30	0.24	0.19	0.16	0.14	0.14	
Low Temperature Characteristics (Max. Impedance Ratio)	Rated voltage (V _{dc})	4V	6.3V	10V	16V	25V	35V	50V	(at 120Hz)
	Z(-25°C)/Z(+20°C)	7	4	3	2	2	2	2	
	Z(-40°C)/Z(+20°C)	15	8	8	4	4	3	3	
Endurance	The following specifications shall be satisfied when the capacitors are restored to 20°C after the rated voltage is applied for 2000 hours at 85°C.								
	Rated voltage	4 & 6.3V _{dc}			10 to 50V _{dc}				
	Capacitance change	≤±30% of the initial value			≤±25% of the initial value				
	DF (tanδ)	≤300% of the initial specified value			≤300% of the initial specified value				
	Leakage current	≤The initial specified value			≤The initial specified value				
Shelf Life	The following specifications shall be satisfied when the capacitors are restored to 20°C after exposing them for 1000 hours at 85°C without voltage applied.								
	Rated voltage	4 & 6.3V _{dc}			10 to 50V _{dc}				
	Capacitance change	≤±30% of the initial value			≤±25% of the initial value				
	DF (tanδ)	≤300% of the initial specified value			≤300% of the initial specified value				
	Leakage current	≤The initial specified value			≤The initial specified value				

◆ DIMENSIONS (Terminal Type=VC) [mm]

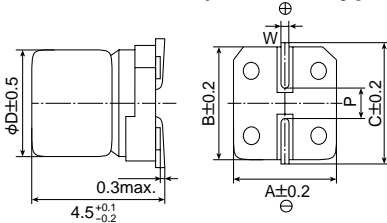

Case code	D	A	B	C	W	P
D46	4	4.3	4.3	5.1	0.5 to 0.8	1.0
E46	5	5.3	5.3	5.9	0.5 to 0.8	1.4
F46	6.3	6.6	6.6	7.2	0.5 to 0.8	1.9

◆ MARKING

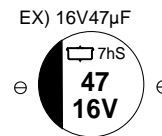

◆ PART NUMBERING SYSTEM

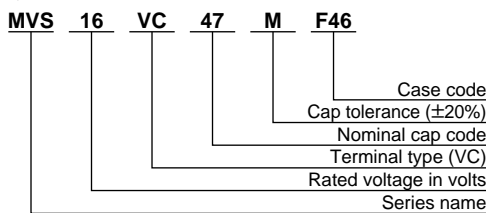

Capacitance	Code
0.1μF	R1
0.47μF	R47
1.0μF	1
4.7μF	4R7
10μF	10
100μF	100

◆ STANDARD RATINGS

μF	V _{dc}	4	6.3	10	16	25	35	50
0.1								D46 1.0
0.22								D46 2.0
0.33								D46 2.8
0.47								D46 4.0
1.0								D46 8.4
2.2								D46 13
3.3								D46 17
4.7								D46 20
10					D46 23		D46 18	E46 20
22					E46 37		E46 29	F46 33
33	D46 28						F46 46	
47	D46 33	E46 45			F46 58	F46 52		
100	E46 56	F46 70						
220	F46 96							

Note : → Use next higher voltage part.

Upgrade!
Alchip-MVA Series

- φ4 through φ18 case sizes are fully lined up
- Endurance : 85°C 2000 hours
- Suitable to fit for downsized equipment
- Solvent-proof type except (100 to 450V_{dc}), see page 16

MVA

↑
downsized
MV

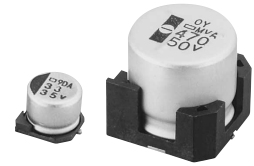

◆SPECIFICATIONS

Items	Characteristics												
Category	Temperature Range												
Temperature Range	-40 to +85°C												
Rated Voltage Range	4 to 450V _{dc}												
Capacitance Tolerance	±20% (M) (at 20°C, 120Hz)												
Leakage Current	Rated voltage (V _{dc})	4 to 100V						160 to 450V					
	D55 to J10	I=0.01CV or 3μA, whichever is greater.(after 2 minutes)						-					
	K14 to M22	I=0.03CV or 4μA, whichever is greater.(after 1 minute)						I=0.03CV or 4μA, whichever is greater.(after 1 minute)					
	Where, I : Max. leakage current (μA), C : Nominal capacitance (μF), V : Rated voltage (V) (at 20°C)												
Dissipation Factor (tanδ)	Rated voltage (V _{dc})	4V	6.3V	10V	16V	25V	35V	50V	63V	100V	160 to 250V	400 & 450V	
	tanδ (Max.)	D55 to J10	0.42	0.35	0.30	0.26	0.16	0.14	0.12	0.12	0.12	-	-
		K14 to M22	-	0.38	0.34	0.30	0.26	0.22	0.18	0.14	0.10	0.20	0.25
	When nominal capacitance exceeds 1000μF, add 0.02 to the value above for each 1000μF increase. (at 20°C, 120Hz)												
Low Temperature Characteristics (Max. Impedance Ratio)	Rated voltage (V _{dc})	4V	6.3V	10V	16V	25V	35V	50V	63V	100V	160 to 250V	400 & 450V	
	D55 to J10	Z(-25°C)/Z(+20°C)	7	4	3	2	2	2	2	2	3	-	-
		Z(-40°C)/Z(+20°C)	17	10	8	6	4	3	3	3	4	-	-
	K14 to M22	Z(-25°C)/Z(+20°C)	-	5	4	3	2	2	2	2	2	3	6
Z(-40°C)/Z(+20°C)		-	12	10	8	5	4	3	3	3	6	10	
(at 120Hz)													
Endurance	The following specifications shall be satisfied when the capacitors are restored to 20°C after the rated voltage is applied for 2000 hours at 85°C.												
	Case code	D55 to J10				D55 to J10				K14 to M22			
	Rated voltage (V _{dc})	4V & 6.3V				10 to 100V				6.3 to 450V			
	Capacitance change	≤±30% of the initial value				≤±20% of the initial value							
	DF (tanδ)	≤200% of the initial specified value				≤200% of the initial specified value							
	Leakage current	≤The initial specified value				≤The initial specified value							
Shelf Life	The following specifications shall be satisfied when the capacitors are restored to 20°C after exposing them for 1000 hours at 85°C without voltage applied.												
	Case code	D55 to J10				D55 to J10				K14 to M22			
	Rated voltage	4V & 6.3V				10 to 100V				6.3 to 450V			
	Capacitance change	≤±30% of the initial value				≤±20% of the initial value							
	DF (tanδ)	≤200% of the initial specified value				≤200% of the initial specified value							
	Leakage current	≤The initial specified value				≤The initial specified value							

◆DIMENSIONS (Terminal Type=VC) [mm]

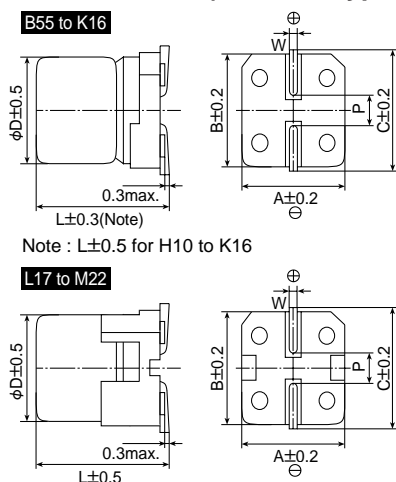

Case code	D	L	A	B	C	W	P
D55	4	5.2	4.3	4.3	5.1	0.5 to 0.8	1.0
E55	5	5.2	5.3	5.3	5.9	0.5 to 0.8	1.4
F55	6.3	5.2	6.6	6.6	7.2	0.5 to 0.8	1.9
F80	6.3	7.7	6.6	6.6	7.2	0.5 to 0.8	1.9
H10	8	10.0	8.3	8.3	9.0	0.7 to 1.1	3.1
J10	10	10.0	10.3	10.3	11.0	0.7 to 1.1	4.5
K14	12.5	13.5	13.0	13.0	13.7	1.0 to 1.3	4.2
K16	12.5	16.0	13.0	13.0	13.7	1.0 to 1.3	4.2
L17	16	16.5	17.0	17.0	18.0	1.0 to 1.3	6.5
L22	16	21.5	17.0	17.0	18.0	1.0 to 1.3	6.5
M17	18	16.5	19.0	19.0	20.0	1.0 to 1.3	6.5
M22	18	21.5	19.0	19.0	20.0	1.0 to 1.3	6.5

◆MARKING

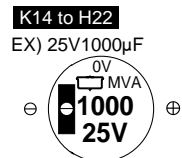
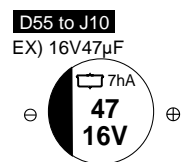

◆PART NUMBERING SYSTEM

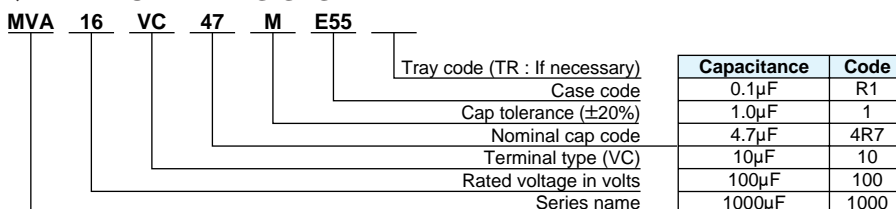

Upgrade!

Alchip® **MVA** Series

◆ **STANDARD RATINGS**

μF \ V_{dc}	4		6.3		10		16		25		35		50		
3.3													D55	15	
4.7												D55	18	D55	18
10															
22					D55	26	D55	26	D55	24	D55	24	E55	30	
33	D55	25	D55	30	D55	30	E55	37	E55	41	E55	41	F55	47	
47	D55	30	D55	33	E55	44	E55	44	F55	47	F55	54	F80	70	
56									F55	60	F60	64	F80	85	
100	E55	50	E55	55	F55	70	F55	70	F80	120	F80	120	H10	190	
150					F55	79	F80	110	H10	210	H10	210			
220	F55	80	F55	88	F80	130	F80	130	H10	260	H10	260	J10	320	
330	F80	135	F80	135	H10	270	H10	270	H10	300	J10	360	K14	600	
470	F80	150	H10	280	H10	280	H10	280	J10	400	K14	600	K16 L17	740 850	
680			H10	290			J10	380							
820			H10	320											
1,000	H10	320	J10	430	J10	430	K14	710	K14	820	L17	1100	L22 M22	1300 1400	
1,500			J10	480											
2,200			K14	890	K14	960	L17	1150	L22 M17	1450 1400	M22	1700			
3,300			K16 L17	1000 1200	L17	1300	L22 M17	1450 1450	M22	1800					
4,700			L17	1400	L22 M17	1550 1600	M22	1750							
6,800			L22 M17	1750 1700	M22	1850									
10,000			M22	2000											

Rated ripple current (mArms) at 85°C, 120Hz
 Case code

Non solvent-proof														
μF \ V_{dc}	63		100		160		200		250		400		450	
0.10	D55	1.3												
0.22	D55	3												
0.33	D55	4												
0.47	D55	5												
1.0	D55	8												
2.2	D55	12												
3.3	E55	17												
4.7	E55	20												
10	F55	32							K14	150	L17	140	L17	140
22	F80	60	H10	90			K14	240	K16	240	L22 M17	280 280	L22	280
33	H10	110	J10	120			K16	310	L17	340	M22	350	M22	350
47	H10	130			K16	370	L17	420	L22 M17	420 420				
56	J10	160												
68	J10	170	K14	380	L17	500	L22 M17	510 510	M22	490				
100	K14	380	K14	440	L22 M17	590 590	M22	590						
220	K14	580	L22 M17	850 800										
330	K16 L17	720 820	M22	1000										
470	L17 M17	950 1000												

Rated ripple current (mArms) at 85°C, 120Hz
 Case code

Alchip[®]-MV Series

- From 5.5mm height
- Suitable to fit for downsized equipment
- Solvent-proof type, see page 16

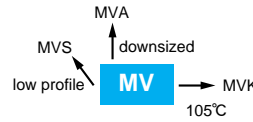

◆ SPECIFICATIONS

Items	Characteristics										
Category	Surface Mount Aluminum Electrolytic Capacitors										
Temperature Range	-40 to +85°C										
Rated Voltage Range	4 to 63V _{dc}										
Capacitance Tolerance	±20% (M) (at 20°C, 120Hz)										
Leakage Current	I=0.01CV or 3μA, whichever is greater. Where, I : Max. leakage current (μA), C : Nominal capacitance (μF), V : Rated voltage (V) (at 20°C after 2 minutes)										
Dissipation Factor (tanδ)	Rated voltage (V _{dc})	4V	6.3V	10V	16V	25V	35V	50V	63V		
	tanδ (Max.)	B55	0.42	0.27	0.23	0.19	0.16	0.14	0.12	—	
		D55 to F60	0.42	0.24	0.20	0.16	0.14	0.12	0.10	0.12	
H63 to J10	—	0.40	0.30	0.26	0.16	0.14	0.12	0.12	0.12		
Low Temperature Characteristics (Max. Impedance Ratio)	Rated voltage (V _{dc})	4V	6.3V	10V	16V	25V	35V	50V	63V		
	Z(-25°C)/Z(+20°C)	7	4	3	2	2	2	2	2		
	Z(-40°C)/Z(+20°C)	B55	17	10	8	6	4	3	3	—	
		D55 to F60	15	10	8	6	4	3	3	3	
H63 to J10	—	10	8	6	4	3	3	3	3		
Endurance	The following specifications shall be satisfied when the capacitors are restored to 20°C after the rated voltage is applied for 2000 hours (B55 size 1000 hours) at 85°C.										
	Capacitance change	≤±20% of the initial value									
	DF (tanδ)	≤200% of the initial specified value									
	Leakage current	≤The initial specified value									
Shelf Life	The following specifications shall be satisfied when the capacitors are restored to 20°C after exposing them for 500 hours at 85°C without voltage applied.										
	Case code	B55				D55 to J10					
	Capacitance change	≤±20% of the initial value				≤±15% of the initial value					
	DF (tanδ)	≤200% of the initial specified value				≤150% of the initial specified value					
	Leakage current	≤The initial specified value				≤The initial specified value					

◆ DIMENSIONS (Terminal Type=VC) [mm]

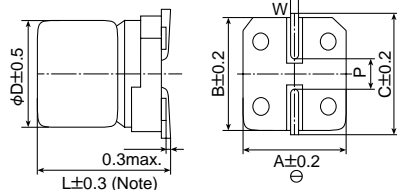

Case code	D	L	A	B	C	W	P
B55	3	5.2	3.3	3.3	3.7	0.45 to 0.75	0.8
D55 & D60	4	*5.2	4.3	4.3	5.1	0.5 to 0.8	1.0
E55	5	5.2	5.3	5.3	5.9	0.5 to 0.8	1.4
F55 & F60	6.3	*5.2	6.6	6.6	7.2	0.5 to 0.8	1.9
H63	8	6.3	8.3	8.3	9.0	0.5 to 0.8	2.3
H10	8	10.0	8.3	8.3	9.0	0.7 to 1.1	3.1
J10	10	10.0	10.3	10.3	11.0	0.7 to 1.1	4.5

* : L=5.7 for D60 and F60.

Note : L±0.5 for φ8×6 (H63), φ8×10 (H10) & φ10×10 (J10).

◆ MARKING



◆ PART NUMBERING SYSTEM

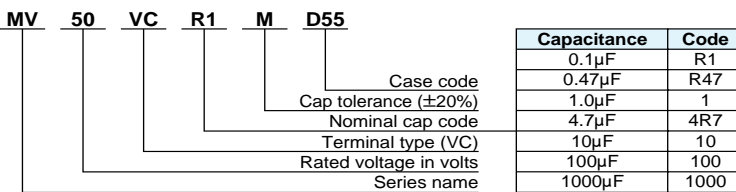

◆ STANDARD RATINGS

μF	V _{dc}	4	6.3	10	16	25	35	50	63
0.1								B55;D55 1.0;1.3	D55 1.3
0.15								B55;D55 2.0;2.0	D55 2.0
0.22								B55;D55 2.0;2.9	D55 2.9
0.33								B55;D55 3.0;3.5	D55 3.5
0.47								B55;D55 3.8;4.2	D55 4.2
0.68								B55;D55 4.6;5.1	D55 5.1
1.0								B55;D55 5.6;6.2	D60 7.0
1.5								B55;D55 6.9;7.5	D60 8.4
2.2							B55 7.7	B55;D55 8.3;10	D60 10
3.3							B55 9.4	D55 14	D60 13
4.7						B55 10.5	D55 15	E55 19	F60 18.5
6.8					B55 11.6	D55 16	E55 20	F55 24	F60 21
10				B55 12.8	B55;D55 14;17		E55 25	F55 29	H10 46
15				D55 20	E55 26		F55 33	F60 32	H10 52
22	B55	14	B55;D55 17.5;23		E55 32		F55 40	F60 45	H10 69
33	D55	23		E55 35		F55 45	F60 55	H63 95	H10 85
47	D55	27	E55 38		F55 50	F60 65	H63 105	H10 140	H10 101
68	E55	38		F55 54	F60 78	H63 115	H10 157	J10 170	J10 125
100	E55	46	F55 60	F60 70		H63 145	H10 175	J10 195	
220	F55	74		H63 175	H10 215		J10 265		
330			H63 190		H10 270	J10 305			
470			H10 265		J10 330				
1,000			J10 400						

Note : → Use next higher voltage part.

New! Alchip® MVE Series

- Rated voltage range : 6.3 to 450V, capacitance range : 0.47 to 6800μF
- Endurance : 1000 to 2000 hours at 105°C
- Case size range : φ4×5.5 to φ18×21.5
- Solvent-proof type except 160V to 450V products, see page 16

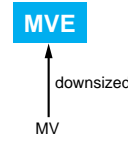

◆ SPECIFICATIONS

Items	Characteristics												
Category	-40 to +105°C												
Temperature Range													
Rated Voltage Range	6.3 to 450V _{dc}												
Capacitance Tolerance	±20%(M) (20°C, 120Hz)												
Leakage Current	Rated voltage(V _{dc})	6.3 to 100V						160 to 450V					
	D55 to J10	I=0.01CV or 3μA, whichever is greater (2 minutes)						—					
	K14 to M22	I=0.03CV or 4μA, whichever is greater (1 minute)						I=0.04CV+100μA (1minute)					
	Where, I : Max. leakage current (μA), C : Nominal capacitance (μF), V : Rated voltage (V) (20°C)												
Dissipation Factor (tanδ)	See STANDARD RATINGS (20°C, 120Hz)												
Low Temperature Characteristics (Max. Impedance Ratio)	Rated voltage (V _{dc})	6.3V	10V	16V	25V	35V	50V	63V	100V	160 to 250V	400 to 450V		
	D55 to J10	Z(-25°C)/Z(+20°C)	4	3	2	2	2	2	2	3	—	—	(120Hz)
		Z(-40°C)/Z(+20°C)	12	8	6	4	3	3	3	4	—	—	
	K14 to M22	Z(-25°C)/Z(+20°C)	5	4	3	2	2	2	2	2	3	6	
Z(-40°C)/Z(+20°C)		10	8	6	4	3	3	3	3	6	10		
Endurance	The following specifications shall be satisfied when the capacitors are restored to 20°C after the rated voltage is applied for the specified period of time at 105°C.												
	Case code	D55 to F80					H10 to M22						
	Time	1000 hours					2000 hours						
	Capacitance change	≤±30% of the initial value					≤±20% of the initial value						
	DF (tanδ)	≤300% of the initial specified value					≤200% of the initial specified value						
	Leakage current	≤The initial specified value					≤The initial specified value						
Shelf Life	The following specifications shall be satisfied when the capacitors are restored to 20°C after exposing them for 1000 hours (500 hours for B55 to F80 size) at 105°C without voltage applied.												
	Case code	D55 to F80					H10 to H22						
	Capacitance change	≤±25% of the initial value					≤±20% of the initial value						
	DF (tanδ)	≤200% of the initial specified value					≤200% of the initial specified value						
	Leakage current	≤The initial specified value					≤The initial specified value						

◆ DIMENSIONS (Terminal Type=VC) [mm]

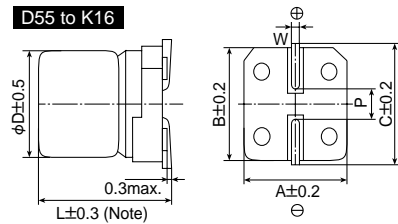

Note : L±0.5 for H10, J10, K14 and K16

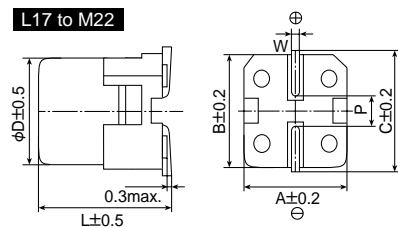

Case code	D	L	A	B	C	W	P
D55	4	5.2	4.3	4.3	5.1	0.5~0.8	1.0
E55	5	5.2	5.3	5.3	5.9	0.5~0.8	1.4
F55	6.3	5.2	6.6	6.6	7.2	0.5~0.8	1.9
F60	6.3	5.7	6.6	6.6	7.2	0.5~0.8	1.9
F80	6.3	7.7	6.6	6.6	7.2	0.5~0.8	1.9
H10	8	10.0	8.3	8.3	9.0	0.7~1.1	3.1
J10	10	10.0	10.3	10.3	11.0	0.7~1.1	4.5
K14	12.5	13.5	13.0	13.0	13.7	1.0~1.3	4.2
K16	12.5	16.0	13.0	13.0	13.7	1.0~1.3	4.2
L17	16	16.5	17.0	17.0	18.0	1.0~1.3	6.5
L22	16	21.5	17.0	17.0	18.0	1.0~1.3	6.5
M17	18	16.5	19.0	19.0	20.0	1.0~1.3	6.5
M22	18	21.5	19.0	19.0	20.0	1.0~1.3	6.5

◆ MARKING

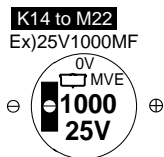
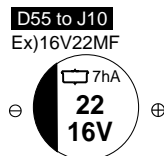

◆ PART NUMBERING SYSTEM

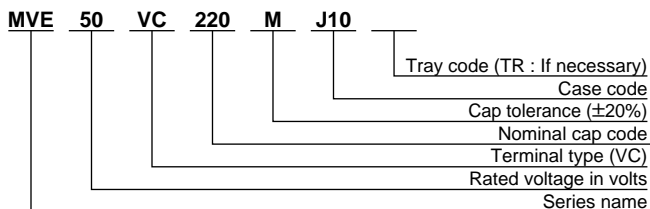

Capacitance	Code
10μF	10
100μF	100
1000μF	1000

◆ **STANDARD RATINGS**

μF \ V _{dc}	6.3			10			16			25			35			50			63					
	0.47																D55	5	0.12	D55	5	0.12		
1.0																D55	8	0.12	D55	8	0.12			
2.2																D55	12	0.12	D55	12	0.12			
3.3																D55	15	0.12	E55	17	0.12			
4.7													D55	16	0.14	E55	20	0.12	F55	22	0.12			
10							D55	17	0.20	E55	27	0.16	E55	27	0.14	F55	32	0.12	F55	32	0.12			
22	D55	22	0.30	E55	30	0.24	E55	30	0.20	F55	44	0.16	F55	44	0.14	F60	47	0.12	F80	58	0.12			
33	E55	34	0.30	E55	34	0.24	F55	45	0.20	F55	50	0.16	F60	54	0.14	F80	65	0.14	H10	140	0.12			
47	E55	38	0.30	F55	48	0.24	F55	48	0.20	F55	60	0.16	F80	80	0.16	F80	80	0.14	H10	170	0.12			
100	F55	69	0.30	F55	69	0.30	F55	69	0.26	F80	100	0.18	F80	100	0.16	H10	230	0.14	J10	310	0.12			
150				F80	100	0.35	F80	100	0.28	H10	240	0.18	H10	260	0.16									
220	F80	120	0.45	F80	120	0.35	F80	120	0.28	H10	320	0.18	J10	375	0.16	J10	375	0.14	K14	470	0.14	L17	560	0.14
330	H10	290	0.40	H10	290	0.35	H10	290	0.28	J10	450	0.16	J10	450	0.16	K14	500	0.18	L17	700	0.14	M17	750	0.14
470	H10	320	0.45	H10	320	0.35	H10	320	0.28	J10	490	0.18	K14	520	0.22	L17	700	0.18	L22	900	0.14	M17	900	0.14
680	H10	340	0.45				J10	470	0.28															
1,000	J10	410	0.40	J10	410	0.35	K14	550	0.30	L17	820	0.26	L17	750	0.22	M22	1200	0.18						
1,500	J10	550	0.45				L17	650	0.30	M17	880	0.26	M17	1000	0.22									
2,200	K14	680	0.40	K16	750	0.36	L17	950	0.32	L22	1250	0.28	M22	1450	0.24									
3,300	L17	840	0.40	L17	850	0.36	M17	1000	0.32	M22	1300	0.28												
4,700	K16	850	0.42	L17	1000	0.38	L22	1200	0.34															
6,800	M17	1000	0.42	M17	1100	0.38	M17	1200	0.34															
	L22	1200	0.44	L22	1300	0.40																		
	M17	1200	0.44	M22	1350	0.40																		
	L22	1200	0.48																					
	M22	1350	0.48																					

DF (tanδ at 20°C, 120Hz)
 Rated ripple current (mArms at 105°C, 120Hz)
 Case code

Non solvent-proof																				
μF \ V _{dc}	100			160			200			250			400			450				
	3.3																K14	40	0.20	
4.7										K14	65	0.15	K16	50	0.20	K16	50	0.20		
10							K14	80	0.15	K16	105	0.15	L17	85	0.20	L17	85	0.20		
22	H10	100	0.12				K16	110	0.15	L17	180	0.15	M22	130	0.20	M22	130	0.20		
33	J10	150	0.12	K14	95	0.15	L17	220	0.15	L22	230	0.15								
47	K14	250	0.10	L17	260	0.15	L22	270	0.15	M17	270	0.15	M22	280	0.15					
68	K14	300	0.10	L22	320	0.15	M22	330	0.15											
100	K14	380	0.10	M17	320	0.15														
220	L17	450	0.10	L22	380	0.15														
330	L22	750	0.10																	
	M17	750	0.10																	
	M22	980	0.10																	

DF (tanδ at 20°C, 120Hz)
 Rated ripple current (mArms at 105°C, 120Hz)
 Case code

Alchip®-MVK Series

- Endurance : 105°C 1000 to 2000 hours
- Suitable to fit for downsized equipment
- Solvent-proof type, see page16

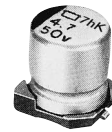
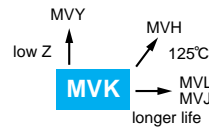

◆SPECIFICATIONS

Items	Characteristics							
Category	-40 to +105°C							
Temperature Range	-40 to +105°C							
Rated Voltage Range	6.3 to 50V _{dc}							
Capacitance Tolerance	±20% (M) (at 20°C, 120Hz)							
Leakage Current	I=0.01CV or 3μA, whichever is greater. (at 20°C after 2 minutes)							
Dissipation Factor (tanδ)	Rated voltage (V _{dc})	6.3V	10V	16V	25V	35V	50V	
	tanδ (Max.)	D55 to F55	0.30	0.24	0.20	0.16	0.14	0.12
Low Temperature Characteristics (Max. Impedance Ratio)	Rated voltage (V _{dc})	6.3V	10V	16V	25V	35V	50V	
	Z(-25°C)/Z(+20°C)	4	3	2	2	2	2	
	Z(-40°C)/Z(+20°C)	10	8	6	4	3	3	(at 120Hz)
Endurance	The following specifications shall be satisfied when the capacitors are restored to 20°C after the rated voltage is applied for the specified period of time at 105°C.							
	Case code	D55 to F55			H63 to J10			
	Time	1000hours			2000hours			
	Capacitance change	≤±30% of the initial value			≤±20% of the initial value			
	DF (tanδ)	≤300% of the initial specified value			≤200% of the initial specified value			
	Leakage current	≤The initial specified value			≤The initial specified value			
Shelf Life	The following specifications shall be satisfied when the capacitors are restored to 20°C after exposing them for the specified time at 105°C without voltage applied.							
	Case code	D55 to F55			H63 to J10			
	Time	500hours			1000hours			
	Capacitance change	≤±25% of the initial value			≤±20% of the initial value			
	DF (tanδ)	≤200% of the initial specified value			≤200% of the initial specified value			
	Leakage current	≤The initial specified value			≤The initial specified value			

◆DIMENSIONS (Terminal Type=VC) [mm]

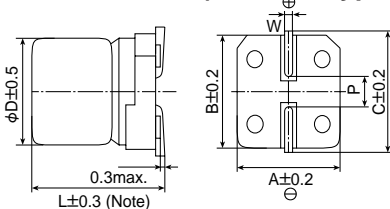

Note : L±0.5 for φ8×6 (H63), φ8×10 (H10), and φ10×10 (J10) .

Case code	D	L	A	B	C	W	P
D55	4	5.2	4.3	4.3	5.1	0.5 to 0.8	1.0
E55	5	5.2	5.3	5.3	5.9	0.5 to 0.8	1.4
F55	6.3	5.2	6.6	6.6	7.2	0.5 to 0.8	1.9
H63	8	6.3	8.3	8.3	9.0	0.5 to 0.8	2.3
H10	8	10.0	8.3	8.3	9.0	0.7 to 1.1	3.1
J10	10	10.0	10.3	10.3	11.0	0.7 to 1.1	4.5

◆MARKING

EX) 6.3V100μF

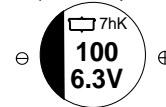

◆PART NUMBERING SYSTEM

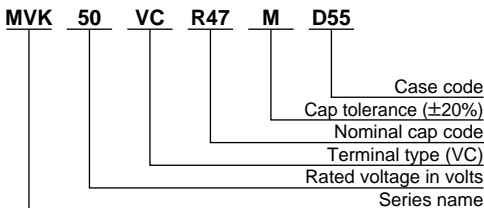

Capacitance	Code
0.1μF	R1
0.47μF	R47
1.0μF	1
4.7μF	4R7
10μF	10
100μF	100
1000μF	1000

◆STANDARD RATINGS

μF	6.3		10		16		25		35		50	
0.1											D55	1.3
0.22											D55	2.6
0.33											D55	3.2
0.47											D55	3.8
1.0											D55	5.6
2.2											D55	10
3.3											D55	14
4.7											E55	19
10											D55	29
22	D55	21			D55	16					E55	25
33					E55	30					F55	29
47	E55	36									F55	40
100	F55	56			H63	90					H63	80
220					H10	180					H10	170
330	H10	290									J10	310
470												
1000	J10	410										

Note : → Use next higher voltage part.

Upgrade!
Alchip[®] MVY Series

- Expand up to $\phi 18$ case size
- Expand up to 100V_{dc}
- Low impedance, 105°C 1000 to 5000 hour-life
- For digital equipment, especially DC-DC converters and VRM

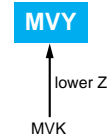

◆ **SPECIFICATIONS**

Items	Characteristics											
Category Temperature Range	-55 to +105°C (6.3 to 63V _{dc})					-40 to +105°C (80 & 100V _{dc})						
Rated Voltage Range	6.3 to 100V _{dc}											
Capacitance Tolerance	±20% (M) (at 20°C, 120Hz)											
Leakage Current	I = 0.01CV or 3μA, whichever is greater. Where, I : Max. leakage current (μA), C : Nominal capacitance (μF), V : Rated voltage (V) (at 20°C after 2 minutes)											
Dissipation Factor (tanδ)	Rated voltage (V _{dc})	6.3V	10V	16V	25V	35V	50V	63V	80V	100V	When nominal capacitance exceeds 1000μF, add 0.02 to the value above for each 1000μF increase. (at 20°C, 120Hz)	
	tanδ (Max.)	D55 to F80	0.24	0.20	0.16	0.14	0.12	0.12	—	—		—
		H10 & J10	0.28	0.24	0.20	0.16	0.14	0.12	—	—		—
Low Temperature Characteristics (Max. Impedance Ratio)	Rated voltage (V _{dc})	6.3V	10V	16V	25V	35V	50V	63V	80V	100V	(at 120Hz)	
	Z(-40°C)/Z(+20°C)	D55 to J10	3	2	2	2	2	2	—	—		—
		K14 to M22	10	8	6	4	3	3	3	3		3
Endurance	The following specifications shall be satisfied when the capacitors are restored to 20°C after the rated voltage is applied for specified time at 105°C.											
	Time	D55 to F80 : 1000 hours H10 & J10 : 2000 hours K14 to M22 : 5000 hours										
	Rated voltage	6.3V _{dc} (D55 to J10)					6.3 to 100V _{dc}					
	Capacitance change	≤±30% of the initial value					≤±20% of the initial value					
	DF (tanδ)	≤300% of the initial specified value					≤200% of the initial specified value					
	Leakage current	≤The initial specified value										
	Shelf Life	The following specifications shall be satisfied when the capacitors are restored to 20°C after exposing them for 1000 hours at 105°C without voltage applied.										
Rated voltage		6.3V _{dc} (D55 to J10)					6.3 to 50V _{dc}					
Capacitance change		≤±30% of the initial value					≤±20% of the initial value					
DF (tanδ)		≤300% of the initial specified value					≤200% of the initial specified value					
Leakage current		≤The initial specified value										

◆ **DIMENSIONS (Terminal Type=VC) [mm]**

D55 to J10

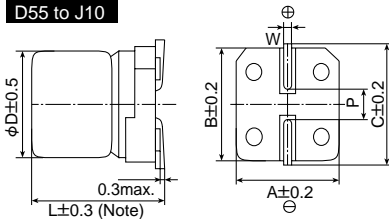

Note : L±0.5 for H10 to K16

K14 to M22

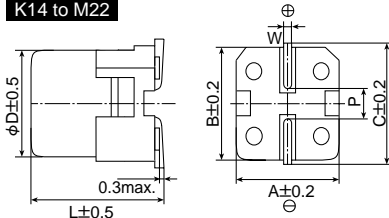

Case code	φD	L	A	B	C	W	P
D55	4.0	5.2	4.3	4.3	5.1	0.5 to 0.8	1.0
E55	5.0	5.2	5.3	5.3	5.9	0.5 to 0.8	1.4
F55	6.3	5.2	6.6	6.6	7.2	0.5 to 0.8	1.9
F80	6.3	7.7	6.6	6.6	7.2	0.5 to 0.8	1.9
H10	8	10.0	8.3	8.3	9.0	0.7 to 1.1	3.1
J10	10	10.0	10.3	10.3	11.0	0.7 to 1.1	4.5
K14	12.5	13.5	13.0	13.0	13.7	1.0 to 1.3	4.2
K16	12.5	16.0	13.0	13.0	13.7	1.0 to 1.3	4.2
L17	16	16.5	17.0	17.0	18.0	1.0 to 1.3	6.5
L22	16	21.5	17.0	17.0	18.0	1.0 to 1.3	6.5
M17	18	16.5	19.0	19.0	20.0	1.0 to 1.3	6.5
M22	18	21.5	19.0	19.0	20.0	1.0 to 1.3	6.5

◆ **MARKING**

D55 to J10

EX) 6.3V100μF



K14 to M22

EX) 16V1000μF

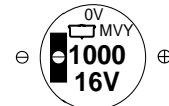

◆ **PART NUMBERING SYSTEM**

MVY 50 VC 220 M J10

Tray code (TR : If necessary)
Case code
Cap tolerance (±20%)
Nominal cap code
Terminal type (VC)
Rated voltage in volts
Series name

Capacitance	Code
1.0μF	1
4.7μF	4R7
10μF	10
100μF	100
1000μF	1000



Upgrade!

Alchip® **MVY** Series

◆ **STANDARD RATINGS**

$\mu F \backslash V_{dc}$	6.3			10			16			25			35		
4.7													D55	3.0	60
10							D55	3.0	60	E55	1.8	95	E55	1.8	95
22	D55	3.0	60	E55	1.8	95	E55	1.8	95	F55	1.0	140	F55	1.0	140
33	E55	1.8	95	E55	1.8	95	F55	1.0	140	F55	1.0	140	F55	1.0	140
47	E55	1.8	95	F55	1.0	140	F55	1.0	140	F55	1.0	140	F55	1.0	140
68													F80	0.34	280
100	F55	1.0	140	F55	1.0	140	F55	1.0	140	F80	0.34	280	H10	0.30	450
220	F55	1.0	140	F80	0.34	280	F80	0.34	280	H10	0.30	450	H10	0.30	450
330	F80	0.34	280	H10	0.30	450	H10	0.30	450	H10	0.30	450	J10	0.15	670
470	H10	0.30	450	H10	0.30	450	H10	0.30	450	J10	0.15	670	K14	0.070	820
680	H10	0.30	450	J10	0.15	670	J10	0.15	670				L17	0.054	1,260
1,000	H10	0.30	450	J10	0.15	670	K14	0.070	820	L17	0.054	1,260	L17	0.054	1,260
1,500	J10	0.15	670				L17	0.054	1,260	M17	0.054	1,350	M17	0.054	1,350
2,200	K14	0.070	820	K16	0.060	950	L17	0.054	1,260	L22	0.038	1,630	M22	0.038	1,750
3,300	L17	0.054	1,260	L17	0.054	1,260	M17	0.054	1,350	M22	0.038	1,750			
4,700	M17	0.054	1,350	M17	0.054	1,350	M17	0.054	1,350	M22	0.038	1,750			
6,800	L22	0.038	1,630	L22	0.038	1,630	M22	0.038	1,750						
8,200	M22	0.038	1,750	M22	0.038	1,750									

— Rated ripple current (mArms) at 105°C, 100kHz
 — Impedance (Ω) at 20°C, 100kHz
 — Case code

		Non solvent-proof											
$\mu F \backslash V_{dc}$	50			63			80			100			
1.0	D55	5.0	30										
2.2	D55	5.0	30										
3.3	D55	5.0	30										
4.7	E55	3.0	50										
10	F55	2.0	70										
22	F55	2.0	70										
33	F80	0.60	170										
47	F80	0.60	170							K14	0.33	450	
68	H10	0.60	300	K14	0.19	500				K14	0.33	450	
100	H10	0.60	300	K14	0.19	500	K14	0.33	450	L17	0.24	650	
220	J10	0.30	500	L17	0.12	845	K16	0.26	550	L22	0.16	900	
330	K14	0.11	650	L17	0.12	845	L22	0.16	900	M17	0.24	700	
470	L17	0.087	900	M17	0.12	905	M17	0.24	700				
1,000	M17	0.087	1,060	L22	0.085	1,100	M22	0.16	950				
	M22	0.050	1,520	M17	0.12	905							

— Case code
 — Impedance (Ω) at 20°C, 100kHz
 — Rated ripple current (mArms) at 105°C, 100kHz



Alchip® MVJ Series

- Endurance : 105°C 2000 hours
- Solvent-proof type, see page 16

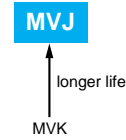

◆ SPECIFICATIONS

Items	Characteristics							
Category	-40 to +105°C							
Temperature Range	-40 to +105°C							
Rated Voltage Range	6.3 to 50V _{dc}							
Capacitance Tolerance	±20% (M) (at 20°C, 120Hz)							
Leakage Current	I=0.01CV or 3μA, whichever is greater. Where, I : Max. leakage current (μA), C : Nominal capacitance (μF), V : Rated voltage (V) (at 20°C after 2 minutes)							
Dissipation Factor (tanδ)	Rated voltage (V _{dc})	6.3V	10V	16V	25V	35V	50V	(at 20°C, 120Hz)
	tanδ (Max.)	0.30	0.24	0.20	0.16	0.14	0.12	
Low Temperature Characteristics (Max. Impedance Ratio)	Rated voltage (V _{dc})	6.3V	10V	16V	25V	35V	50V	(at 120Hz)
	Z(-25°C)/Z(+20°C)	4	3	2	2	2	2	
	Z(-40°C)/Z(+20°C)	12	8	6	4	3	3	
Endurance	The following specifications shall be satisfied when the capacitors are restored to 20°C after the rated voltage is applied for 2000 hours at 105°C.							
	Rated voltage	6.3V _{dc}			10 & 16V _{dc}		25 to 50V _{dc}	
	Capacitance change	≤±30% of the initial value			≤±25% of the initial value		≤±20% of the initial value	
	DF (tanδ)	≤300% of the initial specified value			≤300% of the initial specified value		≤200% of the initial specified value	
	Leakage current	The initial specified value			≤The initial specified value		≤The initial specified value	
Shelf Life	The following specifications shall be satisfied when the capacitors are restored to 20°C after exposing them for 1000 hours at 105°C without voltage applied.							
	Rated voltage	6.3V _{dc}			10 & 16V _{dc}		25 to 50V _{dc}	
	Capacitance change	≤±30% of the initial value			≤±25% of the initial value		≤±20% of the initial value	
	DF (tanδ)	≤300% of the initial specified value			≤300% of the initial specified value		≤200% of the initial specified value	
	Leakage current	≤The initial specified value			≤The initial specified value		≤The initial specified value	

◆ DIMENSIONS (Terminal Type=VC) [mm]

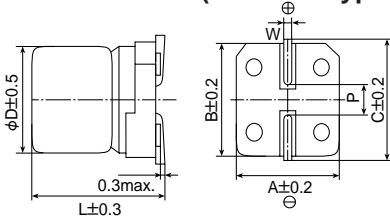

Case code	D	L	A	B	C	W	P
D60	4	5.7	4.3	4.3	5.1	0.5 to 0.8	1.0
E60	5	5.7	5.3	5.3	5.9	0.5 to 0.8	1.4
F60	6.3	5.7	6.6	6.6	7.2	0.5 to 0.8	1.9

◆ MARKING

EX) 6.3V100μF

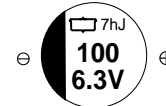

◆ PART NUMBERING SYSTEM

MVJ 16 VC 22 M E60

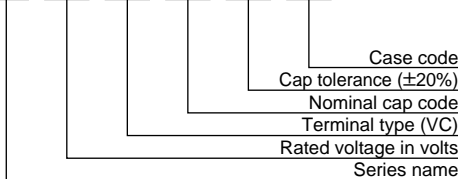

Capacitance	Code
0.1μF	R1
1.0μF	1
4.7μF	4R7
10μF	10
100μF	100

◆ STANDARD RATINGS

μF \ V _{dc}	6.3	10	16	25	35	50
0.1						D60 1.3
0.22						D60 2.6
0.33						D60 3.2
0.47						D60 3.8
1.0						D60 5.6
2.2						D60 10
3.3						D60 14
4.7					D60 15	E60 19
10					E60 25	F60 29
22	D60 21		D60 16		F60 40	
33		E60 34	E60 30			
47	E60 36		F60 48	F60 45		
100	F60 56					

Note : → Use next higher voltage part.

Upgrade! **Alchip[®] MVL Series**

- Load life : 105°C 3000 to 5000 hours (F80 to J10 added)
- Solvent-proof type
- Suitable for applications requiring long life such as continuously operating equipment, industrial applications, etc

MVL

↑ Longer life
MVJ



◆ **SPECIFICATIONS**

Items	Characteristics							
Category	-40 to +105°C							
Temperature Range	-40 to +105°C							
Rated Voltage Range	6.3 to 50V _{dc}							
Capacitance Tolerance	±20%(M) (at 20°C, 120Hz)							
Leakage Current	I=0.03CV or 4μA, whichever is greater Where, I : Max. leakage current (μA), C : Nominal capacitance (μF), V : Rated voltage (V) (at 20°C, after 2 minutes)							
Dissipation Factor (tanδ)	Rated voltage (V _{dc})	6.3V	10V	16V	25V	35V	50V	(at 20°C, 120Hz)
	Max. tanδ	0.28	0.24	0.20	0.16	0.13	0.12	
Low Temperature Characteristics (Max. impedance Ratio)	Rated voltage (V _{dc})	6.3V	10V	16V	25V	35V	50V	(120Hz)
	Z(-25°C)/Z(+20°C)	4	3	2	2	2	2	
	Z(-40°C)/Z(+20°C)	10	7	5	3	3	3	
Endurance	After the capacitors are subjected to the rated DC voltage for 3000 hours (H10 & J10 sizes 5000 hours) at 105°C, the following specifications shall be satisfied when the capacitors are restored to 20°C.							
	Capacitance change	≤±30% of the initial measured value						
	D.F. (tanδ)	≤300% of the initial specified value						
	Leakage current	≤The initial specified value						
Shelf Life	The following specifications shall be satisfied when the capacitors are restored to 20°C after exposing them for 1000 hours at 105°C without voltage applied. The rated voltage shall be applied to the capacitors for a minimum of 30 minutes, at least 24 hours and not more than 48 hours before the measurements.							
	Capacitance change	≤±30% of the initial measured value						
	D.F. (tanδ)	≤300% of the initial specified value						
	Leakage current	≤The initial specified value						

◆ **DIMENSIONS (Terminal Type=VC) [mm]**

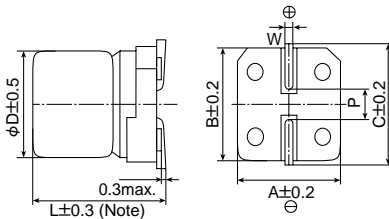

Note : L±0.5 for H10 to J10

Case code	Outer dimensions							Land			
	D	L	A	B	C	W	P	a	b	c	
D60	4.0	5.7	4.3	4.3	5.1	0.5 - 0.8	1.0	1.0	2.6	1.6	
E60	5.0	5.7	5.3	5.3	5.9	0.5 - 0.8	1.4	1.4	3.0	1.6	
F60	6.3	5.7	6.6	6.6	7.2	0.5 - 0.8	1.9	1.9	3.5	1.6	
F80	6.3	7.7	6.6	6.6	7.2	0.5 - 0.8	1.9	1.9	3.5	1.6	
H63	8	6.3	8.3	8.3	9.0	0.5 - 0.8	2.3	2.3	4.5	1.6	
H10	8	10.0	8.3	8.3	9.0	0.7 - 1.1	3.1	3.1	4.2	2.2	
J10	10	10.0	10.3	10.3	11.0	0.7 - 1.1	4.5	4.5	4.4	2.2	

◆ **MARKING**

EX) 16V47μF



◆ **PART NUMBERING SYSTEM**

MVL 35 VC 10 M E60

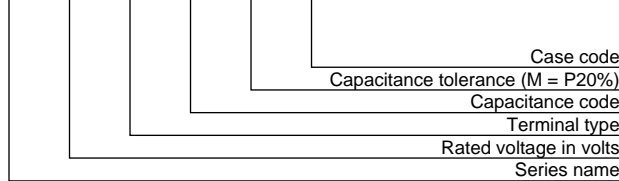

Capacitance	Code
0.1μF	R1
2.2μF	2R2
10μF	10
100μF	100

◆ **STANDARD RATINGS**

μF \ V _{dc}	6.3	10	16	25	35	50
0.1						D60 1.0
0.22						D60 2.6
0.33						D60 3.2
0.47						D60 3.8
1.0						D60 6.2
2.2						D60 11
3.3						D60 14
4.7						D60 19
10						D60 25
22	D60	22				E60 30
33			E60	35		F60 42
47	E60	36			F60	F80 48
100					F80	F80 57
220	F60	60				H10 63
330						H10 92
470	F80	101	H10	141		J10 116
1,000	H10	160				J10 216
						J10 238
						J10 254

Note : → Use a next higher voltage capacitor.
Contact us for reflow soldering conditions.

* Specifications are subject to change without notice.



SURFACE MOUNT ALUMINUM ELECTROLYTIC CAPACITORS

High heat resistance, 125°C

Upgrade! Alchip® MVH Series

- Endurance : 125°C 1000 to 5000 hours
- Suitable to fit for automotive equipment
- Solvent-proof type (10 to 50V), see page16

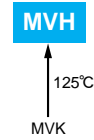

◆ SPECIFICATIONS

Items	Characteristics										
Category	-40 to +125°C										
Temperature Range											
Rated Voltage Range	10 to 450V _{dc}										
Capacitance Tolerance	±20% (M) (at 20°C, 120Hz)										
Leakage Current	10 to 100V _{dc}					160 to 450V _{dc}					
	I=0.03CV or 4μA, whichever is greater.					I=0.04CV+100 (160 to 450V _{dc})					
	Where, I : Max. leakage current (μA), C : Nominal capacitance (μF), V : Rated voltage (V) (at 20°C after 2 minutes)										
Dissipation Factor (tanδ)	Rated voltage (V _{dc})	10V	16V	25V	35V	50V	63V	100V	160 to 250V	400 & 450V	
	tanδ (Max.)	F60 to J10	0.24	0.20	0.16	0.14	0.14	0.18	0.18	—	
		K14 to M22	0.22	0.18	0.16	0.14	0.12	0.14	0.10	0.20	
When nominal capacitance exceeds 1000μF, add 0.02 to the value above for each 1000μF increase. (at 20°C, 120Hz)											
Low Temperature Characteristics (Max. Impedance Ratio)	Rated voltage (V _{dc})	10V	16V	25V	35V	50V	63V	100V	160 to 250V	400 & 450V	
	F60 to J10	Z(-25°C)/Z(+20°C)	4	3	2	2	2	2	2	—	—
		Z(-40°C)/Z(+20°C)	10	8	6	4	4	4	4	—	—
	K14 to M22	Z(-25°C)/Z(+20°C)	4	3	2	2	2	2	2	3	6
Z(-40°C)/Z(+20°C)		8	6	4	3	3	3	3	6	10	
(at 120Hz)											
Endurance	The following specifications shall be satisfied when the capacitors are restored to 20°C after the rated voltage is applied for the specified time at 125°C.										
	Time	F60 to H63 (10 to 100V _{dc}) : 1000hours									
		H10 to J10 (10 to 100V _{dc}) : 2000hours									
		K14 to M22 (10 to 100V _{dc}) : 5000hours									
		K14 to M22 (160 to 450V _{dc}) : 2000hours									
	Capacitance change	≤±30% of the initial value									
DF (tanδ)	≤300% of the initial specified value										
Leakage current	≤The initial specified value										
Shelf Life	The following specifications shall be satisfied when the capacitors are restored to 20°C after exposing them for 1000 hours (500 hours for 350 to 450VV) at 125°C without voltage applied.										
	Rated voltage(V _{dc})	10 to 50V _{dc}					63 to 450V _{dc}				
	Capacitance change	≤±30% of the initial value					≤±30% of the initial value				
	DF (tanδ)	≤300% of the initial specified value					≤300% of the initial specified value				
	Leakage current	≤The initial specified value					≤500% of the initial specified value				

◆ DIMENSIONS (Terminal Type=VC) [mm]

F60 to K16

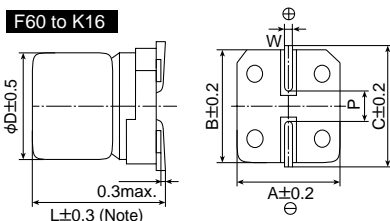

Note : L±0.5 for H63 to K16

L17 to M22

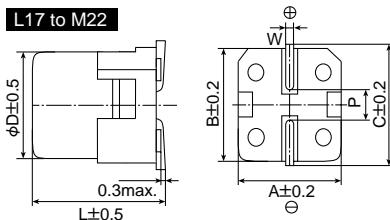

Case code	D	L	A	B	C	W	P
F60	6.3	5.7	6.6	6.6	7.2	0.5 to 0.8	1.9
F80	6.3	7.7	6.6	6.6	7.2	0.5 to 0.8	1.9
H63	8	6.3	8.3	8.3	9.0	0.5 to 0.8	2.3
H10	8	10.0	8.3	8.3	9.0	0.7 to 1.1	3.1
J10	10	10.0	10.3	10.3	11.0	0.7 to 1.1	4.5
K14	12.5	13.5	13.0	13.0	13.7	1.0 to 1.3	4.2
K16	12.5	16.0	13.0	13.0	13.7	1.0 to 1.3	4.2
L17	16	16.5	17.0	17.0	18.0	1.0 to 1.3	6.5
L22	16	21.5	17.0	17.0	18.0	1.0 to 1.3	6.5
M17	18	16.5	19.0	19.0	20.0	1.0 to 1.3	6.5
M22	18	21.5	19.0	19.0	20.0	1.0 to 1.3	6.5

◆ MARKING

F60 to J10

EX) 35V47μF

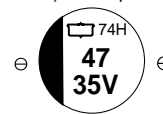

K14 to M22

EX) 16V1000μF

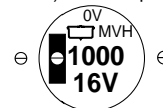

◆ PART NUMBERING SYSTEM

MVH 35 VC 47 M H10

Tray code (TR : If necessary)
 Case code
 Cap tolerance (±20%)
 Nominal cap code
 Terminal type (VC)
 Rated voltage in volts
 Series name

Capacitance	Code
10μF	10
100μF	100
1000μF	1000



Upgrade!

Alchip® **MVH** Series

◆ **STANDARD RATINGS**

μF \ V _{dc}	10				16				25				35			
10													F60	38	3.3	66.0
22													F60	39	3.3	66.0
33									F60	45	3.3	66.0	H63	62	2.3	46.0
47					F60	43	3.3	66.0	H63	68	2.3	46.0	F80	62	2.3	46.0
100	H63	72	2.3	46.0					H10	126	1.0	20.0	H10	92	1.0	20.0
220	F80	72	2.3	46.0					J10	211	0.7	13.4	J10	151	0.7	13.4
330	H10	136	1.0	20.0					K14	750	0.14	2.1	K14	750	0.14	2.1
470	J10	188	0.7	13.4					K14	750	0.14	2.1	L17	1,000	0.10	1.5
680					K14	750	0.14	2.1	L17	1,000	0.10	1.5	K16	900	0.11	1.5
1,000					L17	1,000	0.10	1.5	M17	1,200	0.10	1.5	L17	1,000	0.10	1.5
2,200					M17	1,200	0.10	1.5	M22	1,550	0.058	0.87	M17	1,200	0.10	1.5
3,300																
4,700																

ESR (Ω max.) at -40°C, 100kHz
 ESR (Ω max.) at 20°C, 100kHz
 Rated Ripple current (mA_{rms}) at 125°C, 100kHz
 Case code

Non-solvent proof												
μF \ V _{dc}	50				63				100			
10	F60	38	3.3	66.0	H63	42	2.3	115	H10	53	1.0	50
22	H63	50	2.3	46.0	F80	42	2.3	115	H10	56	1.0	50.0
33	F80	50	2.3	46.0	H10	56	1.0	50.0	J10	63	0.70	35
47	H10	83	1.0	20.0	J10	77	0.7	35.0				
68	J10	111	0.7	13.4					K14	450	0.33	16.5
100									K16	550	0.26	13.0
220	K14	550	0.23	3.5	K14	500	0.25	12.5	L17	650	0.24	12.0
330	K14	550	0.23	3.5	K16	600	0.20	10.0	M22	950	0.16	8.0
470	L17	850	0.15	2.3	L17	820	0.18	9.0				
	K16	700	0.18	2.7	L22	1,100	0.11	5.5				
	L17	850	0.15	2.3								

ESR (Ω max.) at -40°C, 100kHz
 ESR (Ω max.) at 20°C, 100kHz
 Rated Ripple current (mA_{rms}) at 125°C, 100kHz
 Case code

Non-solvent proof										
μF \ V _{dc}	160		200		250		400		450	
3.3									K16	65
4.7							K14	70	L17	85
6.8							L17	100		
10	K14	100	K14	100	K16	110	L22	140	M22	145
22	L17	180	L17	180	L22	205	M17	135		
33	M17	245	L22	250	M17	200				
47			M17	245	M22	260				
68	M22	380	M22	315						

Rated Ripple current (mA_{rms}) at 125°C, 120Hz
 Case code

Alchip[®] MF-BP Series

- 3.5 to 4.5mm height
- Bipolarized chip type for the circuit, of which polarity is frequently reversed
- Solvent-proof type, see page 16

MF-BP

↑ bi-polarized
MF

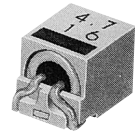

◆ SPECIFICATIONS

Items	Characteristics									
Category	-40 to +85°C									
Temperature Range										
Rated Voltage Range	4 to 50V _{dc}									
Capacitance Tolerance	±20% (M) (at 20°C, 120Hz)									
Leakage Current	I = 0.05CV or 10μA, whichever is greater. Where, I : Max. leakage current (μA), C : Nominal capacitance (μF), V : Rated voltage (V) (at 20°C after 2 minutes)									
Dissipation Factor (tanδ)	Rated voltage (V _{dc})	4V	6.3V	10V	16V	25V	35V	50V	(at 20°C, 120Hz)	
	tanδ (Max.)	B6 & C6	0.50	0.35	0.30	0.26	0.24	0.22		0.22
Low Temperature Characteristics (Max. Impedance Ratio)	Rated voltage (V _{dc})	4V	6.3V	10V	16V	25V	35V	50V	(at 120Hz)	
	Z(-25°C)/Z(+20°C)	B6 & C6	9	6	4	3	2	2		2
		D6 & D8	7	4	3	2	2	2		2
	Z(-40°C)/Z(+20°C)	B6 & C6	17	12	9	7	5	4		4
	D6 & D8	15	10	8	6	4	3	3		
Endurance	The following specifications shall be satisfied when the capacitors are restored to 20°C after the rated voltage is applied for 2000 hours at 85°C, however the polarization shall be reversed every 250 hours.									
	Case code	B6 & C6			D6 & D8					
	Capacitance change	≤±25% of the initial value			≤±20% of the initial value					
	DF (tanδ)	≤200% of the initial specified value			≤200% of the initial specified value					
	Leakage current	≤The initial specified value			≤The initial specified value					
Shelf Life	The following specifications shall be satisfied when the capacitors are restored to 20°C after exposing them for 500 hours at 85°C without voltage applied.									
	Capacitance change	≤±15% of the initial value								
	DF (tanδ)	≤150% of the initial specified value								
	Leakage current	≤The initial specified value								

◆ DIMENSIONS (Terminal Type=FC or FD <dummy terminal>) [mm]

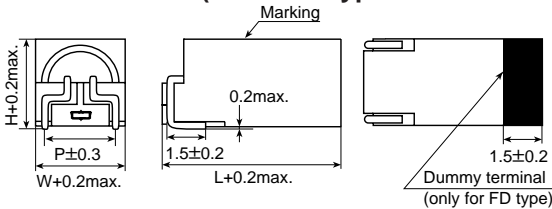

Case code	L	W	H	P
B6	6.3	3.6	3.5	3.0
C6	6.3	4.1	4.0	3.5
D6	6.3	4.6	4.5	4.0
D8	8.3	4.6	4.5	4.0

◆ MARKING

EX) 16V3.3μF

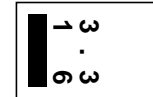

◆ PART NUMBERING SYSTEM

MF 6.3 FC 10 M BP D6

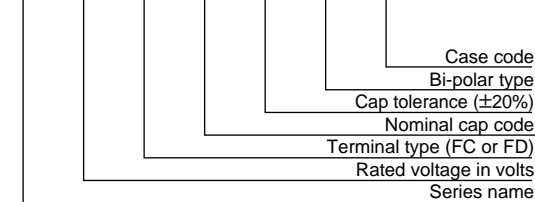

Capacitance	Code
0.1μF	R1
0.47μF	R47
1.0μF	1
4.7μF	4R7
10μF	10

◆ STANDARD RATINGS

μF	V _{dc}		6.3		10		16		25		35		50	
	4	6.3												
0.1													B6	1.3
0.22													B6	2.3
0.33													B6	2.8
0.47													B6	3.3
1.0														
2.2							B6	6.1	C6	7.0	B6	4.6	C6	5.3
3.3							C6	8.2	D6	10	D6	9.1	D8	10
4.7							D6	12	D8	13				
10	C6	9.5	D6	14	D8	16								
22	D8	19												

Alchip® MFK-BP Series

- 3.5 to 4.5mm height
- Bipolarized chip type for the circuit, of which polarity is frequently reversed
- Solvent-proof type, see page 16

MFK-BP

↑
bi-polarized
MFK

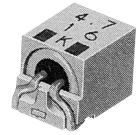

◆ SPECIFICATIONS

Items	Characteristics	
Category Temperature Range	-40 to +105°C	
Rated Voltage Range	6.3 to 50V _{dc}	
Capacitance Tolerance	±20% (M) (at 20°C, 120Hz)	
Leakage Current	I=0.05CV or 10μA, whichever is greater. Where, I : Max. leakage current (μA), C : Nominal capacitance (μF), V : Rated voltage (V) (at 20°C after 2 minutes)	
Dissipation Factor (tanδ)	Rated voltage (V _{dc})	6.3V 10V 16V 25V 35V 50V
	tanδ (Max.)	0.35 0.30 0.26 0.24 0.22 0.22 (at 20°C, 120Hz)
Low Temperature Characteristics (Max. Impedance Ratio)	Rated voltage (V _{dc})	6.3V 10V 16V 25V 35V 50V
	Z(-25°C)/Z(+20°C)	6 4 3 2 2 2 (at 120Hz)
	Z(-40°C)/Z(+20°C)	12 9 7 5 4 4
Endurance	The following specifications shall be satisfied when the capacitors are restored to 20°C after the rated voltage is applied for 1000 hours at 105°C, however the polarization shall be reversed every 250 hours.	
	Case code	B6 & C6 D6 & D8
	Capacitance change	≤±30% of the initial value ≤±20% of the initial value
	DF (tanδ)	≤200% of the initial specified value ≤200% of the initial specified value
	Leakage current	≤The initial specified value ≤The initial specified value
Shelf Life	The following specifications shall be satisfied when the capacitors are restored to 20°C after exposing them for 500 hours at 105°C without voltage applied.	
	Case code	B6 & C6 D6 & D8
	Capacitance change	≤±25% of the initial value ≤±15% of the initial value
	DF (tanδ)	≤200% of the initial specified value ≤150% of the initial specified value
	Leakage current	≤The initial specified value ≤The initial specified value

◆ DIMENSIONS (Terminal Type=FC or FD <dummy terminal>) [mm]

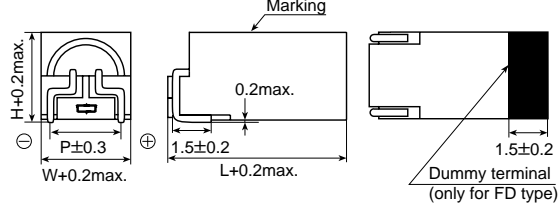

Case code	L	W	H	P
B6	6.3	3.6	3.5	3.0
C6	6.3	4.1	4.0	3.5
D6	6.3	4.6	4.5	4.0
D8	8.3	4.6	4.5	4.0

◆ MARKING

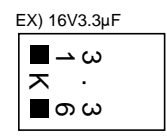

◆ PART NUMBERING SYSTEM

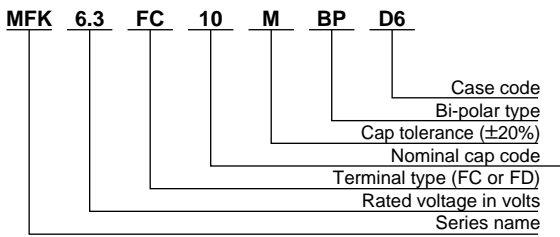

Capacitance	Code
0.1μF	R1
0.47μF	R47
1.0μF	1
4.7μF	4R7
10μF	10

◆ STANDARD RATINGS

μF \ V _{dc}	6.3		10		16		25		35		50	
0.1											B6	1.3
0.22											B6	1.9
0.33											B6	2.4
0.47											B6	2.8
1.0											B6	4.5
2.2											D6	8.2
3.3	B6	6.2	B6	6.4	C6	7.6	D6	8.8	D8	10.1		
4.7	B6	7.1	C6	8.4	D6	10.1	D8	11.5				
10	D6	12.7	D8	15								

Case code

Rated ripple current (mArms) at 105°C, 120Hz

Alchip® MV-BP Series

- Bipolarized chip type for the circuit, of which polarity is frequently reversed
- Solvent-proof type, see page 16

MV-BP

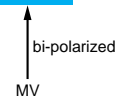

◆ SPECIFICATIONS

Items	Characteristics								
Category	-40 to +85°C								
Temperature Range	-40 to +85°C								
Rated Voltage Range	4 to 50V _{dc}								
Capacitance Tolerance	±20% (M) (at 20°C, 120Hz)								
Leakage Current	I=0.05CV or 10μA, whichever is greater. Where, I : Max. leakage current (μA), C : Nominal capacitance (μF), V : Rated voltage (V) (at 20°C after 2 minutes)								
Dissipation Factor (tanδ)	Rated voltage (V _{dc})	4V	6.3V	10V	16V	25V	35V	50V	(at 20°C, 120Hz)
	tanδ (Max.)	0.45	0.32	0.26	0.24	0.22	0.20	0.20	
Low Temperature Characteristics (Max. Impedance Ratio)	Rated voltage (V _{dc})	4V	6.3V	10V	16V	25V	35V	50V	(at 120Hz)
	Z(-25°C)/Z(+20°C)	7	4	3	2	2	2	2	
	Z(-40°C)/Z(+20°C)	15	10	8	6	4	3	3	
Endurance	The following specifications shall be satisfied when the capacitors are restored to 20°C after the rated voltage is applied for 2000 hours at 85°C, however the polarization shall be reversed every 250 hours.								
	Capacitance change	≤±20% of the initial value							
	DF (tanδ)	≤200% of the initial specified value							
	Leakage current	≤The initial specified value							
Shelf Life	The following specifications shall be satisfied when the capacitors are restored to 20°C after exposing them for 500 hours at 85°C without voltage applied.								
	Capacitance change	≤±15% of the initial value							
	DF (tanδ)	≤150% of the initial specified value							
	Leakage current	≤The initial specified value							

◆ DIMENSIONS (Terminal Type=VC) [mm]

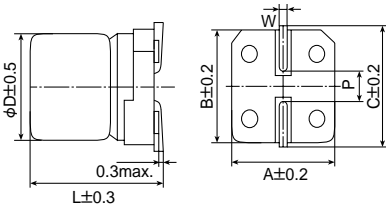

Case code	D	L	A	B	C	W	P
D55	4	5.2	4.3	4.3	5.1	0.5 to 0.8	1.0
E55	5	5.2	5.3	5.3	5.9	0.5 to 0.8	1.4
F55	6.3	5.2	6.6	6.6	7.2	0.5 to 0.8	1.9

◆ MARKING

EX) 35V4.7μF

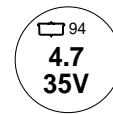

◆ PART NUMBERING SYSTEM

MV 50 VC R47 M BP D55

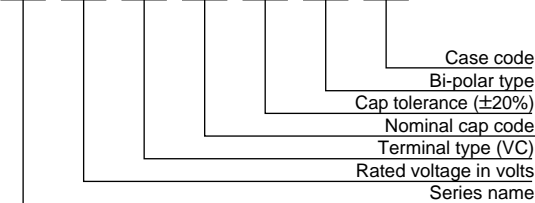

Capacitance	Code
0.1μF	R1
0.47μF	R47
1.0μF	1
4.7μF	4R7
10μF	10

◆ STANDARD RATINGS

μF \ V _{dc}	4	6.3	10	16	25	35	50
0.1							D55 1.3
0.15							D55 1.9
0.22							D55 2.3
0.33							D55 2.8
0.47							D55 3.4
0.68							D55 4.1
1.0							D55 5.5
1.5							D55 6.5
2.2						D55 8	E55 9
3.3					D55 9	E55 11	F55 14
4.7				D55 11	E55 13	F55 17	
6.8				D55 12	E55 15	F55 21	
10				D55 13	E55 18	F55 24	
15	D55 14	E55 21	F55 28				
22		E55 23	F55 33				
33			F55 36				
47							

Note : → Use next higher voltage part.

Alchip® MVK-BP Series

- Bipolarized chip type for the circuit, of which polarity is frequently reversed
- Solvent-proof type, see page 16

MVK-BP

↑ bi-polarized
MVK



◆ SPECIFICATIONS

Items	Characteristics						
Category	-40 to +105°C						
Temperature Range	-40 to +105°C						
Rated Voltage Range	6.3 to 50V _{dc}						
Capacitance Tolerance	±20% (M) (at 20°C, 120Hz)						
Leakage Current	I=0.05CV or 10μA, whichever is greater. Where, I : Max. leakage current (μA), C : Nominal capacitance (μF), V : Rated voltage (V) (at 20°C after 2 minutes)						
Dissipation Factor (tanδ)	Rated voltage (V _{dc})	6.3V	10V	16V	25V	35V	50V
	tanδ (Max.)	0.35	0.26	0.24	0.20	0.18	0.18
Low Temperature Characteristics (Max. Impedance Ratio)	Rated voltage (V _{dc})	6.3V	10V	16V	25V	35V	50V
	Z(-25°C)/Z(+20°C)	4	3	2	2	2	2
	Z(-40°C)/Z(+20°C)	10	8	6	4	3	3
Endurance	The following specifications shall be satisfied when the capacitors are restored to 20°C after the rated voltage is applied for 1000 hours at 105°C, however the polarization shall be reversed every 250 hours.						
	Capacitance change	≤±30% of the initial value					
	DF (tanδ)	≤300% of the initial specified value					
	Leakage current	≤The initial specified value					
Shelf Life	The following specifications shall be satisfied when the capacitors are restored to 20°C after exposing them for 500 hours at 105°C without voltage applied.						
	Capacitance change	≤±25% of the initial value					
	DF (tanδ)	≤200% of the initial specified value					
	Leakage current	≤The initial specified value					

◆ DIMENSIONS (Terminal Type=VC) [mm]

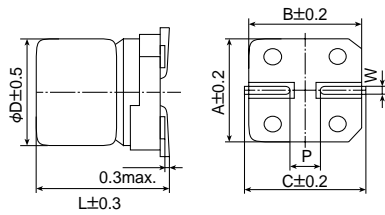

Case code	D	L	A	B	C	W	P
D60	4	5.7	4.3	4.3	5.1	0.5 to 0.8	1.0
E60	5	5.7	5.3	5.3	5.9	0.5 to 0.8	1.4
F60	6.3	5.7	6.6	6.6	7.2	0.5 to 0.8	1.9

◆ MARKING

EX) 35V4.7μF



◆ PART NUMBERING SYSTEM

MVK 50 VC R1 M BP D60

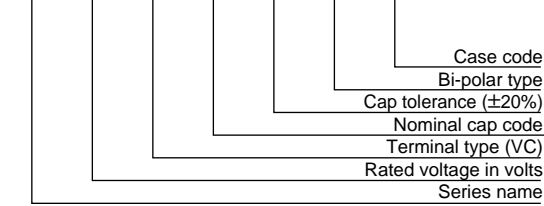

Capacitance	Code
0.1μF	R1
0.47μF	R47
1.0μF	1
4.7μF	4R7
10μF	10

◆ STANDARD RATINGS

μF \ V _{dc}	6.3	10	16	25	35	50
0.10						D60 1.3
0.15						D60 1.9
0.22						D60 2.3
0.33						D60 2.8
0.47						D60 3.4
0.68						D60 4.1
1.0						D60 5.5
1.5						D60 7.5
2.2					D60 8.8	E60 10
3.3				D60 10		E60 13
4.7			D60 12		E60 15	F60 16
6.8		D60 13		E60 17		F60 20
10	D60 14		E60 20		F60 23	
15		E60 22		F60 28		
22	E60 25		F60 32			
33		F60 35				
47	F60 39					

Note : → Use next higher voltage part.

SRM Series

- Coating case covered products are also available
- Downsized from current standard SRE series
- 5mm height, 1000-hour-life at 85°C
- Solvent-proof type, see page 16



◆SPECIFICATIONS

Items	Characteristics								
Category	-40 to +85°C								
Temperature Range									
Rated Voltage Range	4 to 50V _{dc}								
Capacitance Tolerance	±20% (M) (at 20°C, 120Hz)								
Leakage Current	I = 0.01CV or 3μA, whichever is greater. Where, I : Max. leakage current (μA), C : Nominal capacitance (μF), V : Rated voltage (V) (at 20°C after 2 minutes)								
Dissipation Factor (tanδ)	Rated voltage (V _{dc})	4V	6.3V	10V	16V	25V	35V	50V	
	tanδ (Max.)	0.40	0.38	0.30	0.23	0.17	0.15	0.13	(at 20°C, 120Hz)
Low Temperature Characteristics (Max. Impedance Ratio)	Rated voltage (V _{dc})	4V	6.3V	10V	16V	25V	35V	50V	
	Z(-25°C)/Z(+20°C)	7	4	3	2	2	2	2	
	Z(-40°C)/Z(+20°C)	15	8	8	6	4	3	3	(at 120Hz)
Endurance	The following specifications shall be satisfied when the capacitors are restored to 20°C after the rated voltage is applied for 1000 hours at 85°C.								
	Capacitance change	≤±20% of the initial value							
	DF (tanδ)	≤200% of the initial specified value							
	Leakage current	≤The initial specified value							
Shelf Life	The following specifications shall be satisfied when the capacitors are restored to 20°C after exposing them for 1000 hours at 85°C without voltage applied.								
	Capacitance change	≤±20% of the initial value							
	DF (tanδ)	≤200% of the initial specified value							
	Leakage current	≤The initial specified value							

◆DIMENSIONS (Radial Lead Type=VB) [mm]

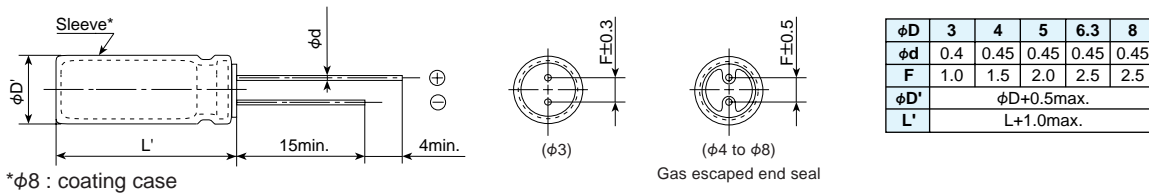

*φ8 : coating case

◆PART NUMBERING SYSTEM

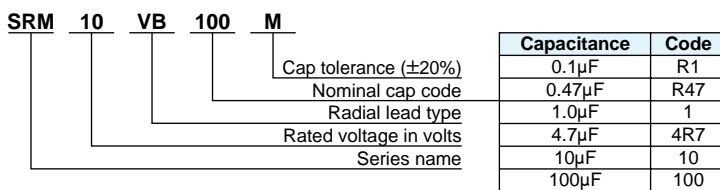

◆STANDARD RATINGS

μF \ V _{dc}	4	6.3	10	16	25	35	50
0.1							3×5 1.3
0.22							3×5 2.9
0.33							3×5 4.2
0.47							3×5 5.0
1.0							3×5 7.2
2.2							3×5 10
3.3						3×5 12	4×5 14
4.7					3×5 13		4×5 19
10				3×5 18	4×5 25		5×5 31
22		3×5 22		4×5 33	5×5 41		6.3×5 49
33			4×5 36	5×5 47		6.3×5 56	8×5 76
47		4×5 40		5×5 55	6.3×5 63	8×5 85	
100	5×5 55		6.3×5 78		8×5 116		
220	6.3×5 88		8×5 148				
330		8×5 141					

Case size φD×L (mm)
Rated ripple current (mArms) at 85°C, 120Hz

Note : → Use next higher voltage part.

SRE Series

- Coating case covered products are also available
- 5mm height, 1000-hour-life at 85°C
- Non solvent-proof

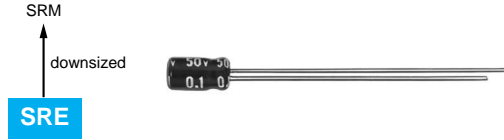

◆SPECIFICATIONS

Items	Characteristics	
Category	-40 to +85°C	
Temperature Range		
Rated Voltage Range	4 to 50V _{dc}	
Capacitance Tolerance	±20% (M) (at 20°C, 120Hz)	
Leakage Current	I=0.01CV or 3μA, whichever is greater. Where, I : Max. leakage current (μA), C : Nominal capacitance (μF), V : Rated voltage (V) (at 20°C after 2 minutes)	
Dissipation Factor (tanδ)	Rated voltage (V _{dc})	4V 6.3V 10V 16V 25V 35V 50V
	tanδ (Max.)	0.35 0.24 0.20 0.16 0.14 0.12 0.10 (at 20°C, 120Hz)
Low Temperature Characteristics (Max. Impedance Ratio)	Rated voltage (V _{dc})	4V 6.3V 10V 16V 25V 35V 50V
	Z(-25°C)/Z(+20°C)	7 4 3 2 2 2 2 (at 120Hz)
	Z(-40°C)/Z(+20°C)	15 10 8 6 4 3 3 (at 120Hz)
Endurance	The following specifications shall be satisfied when the capacitors are restored to 20°C after the rated voltage is applied for 1000 hours at 85°C.	
	Capacitance change	≤±20% of the initial value
	DF (tanδ)	≤200% of the initial specified value
	Leakage current	≤The initial specified value
Shelf Life	The following specifications shall be satisfied when the capacitors are restored to 20°C after exposing them for 1000 hours at 85°C without voltage applied.	
	Capacitance change	≤±20% of the initial value
	DF (tanδ)	≤200% of the initial specified value
	Leakage current	≤The initial specified value

◆DIMENSIONS (Radial Lead Type=VB) [mm]

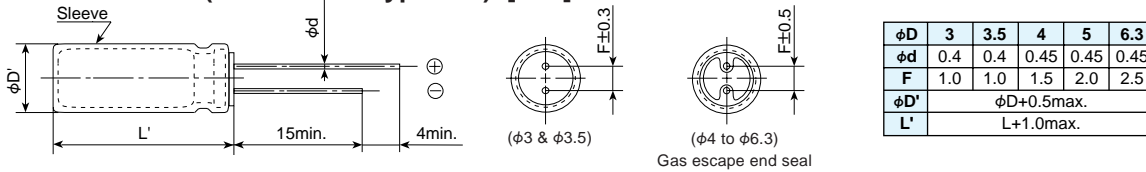

◆PART NUMBERING SYSTEM

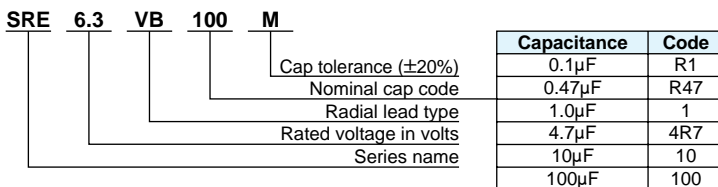

◆STANDARD RATINGS

μF \ V _{dc}	4	6.3	10	16	25	35	50
0.1							3×5 1.3
0.15							3×5 2.0
0.22							3×5 2.9
0.33							3×5 3.5
0.47							3×5 4.2
0.68							3×5 5.1
1.0							3×5 6.2
1.5							3×5 7.5
2.2							3×5 10
3.3					3×5 9.3	3×5 8.3	4×5 14
4.7				3×5 10	3.5×5 12	4×5 15	5×5 19
6.8				3.5×5 14	4×5 16	5×5 20	6.3×5 24
10		3×5 12		3.5×5 17		5×5 25	6.3×5 29
15		3.5×5 17	4×5 20	5×5 26		6.3×5 33	
22		4×5 23		5×5 32		6.3×5 40	
33	4×5 23		5×5 35		6.3×5 45		
47		5×5 38		6.3×5 50			
68			6.3×5 54				
100		6.3×5 60					

Case size φD×L (mm)
Rated ripple current (mA rms) at 85°C, 120Hz

Note1: → Use next higher voltage part.
Note2: The parts of φ3.5×5 will be unified to φ4×5.

KRE Series

- Coating case covered products are also available
- 5mm height, 1000-hour-life at 105°C
- Solvent-proof type, see page 16

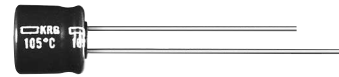
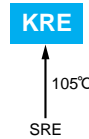

◆ SPECIFICATIONS

Items	Characteristics	
Category	-55 to +105°C	
Temperature Range	-55 to +105°C	
Rated Voltage Range	6.3 to 50V _{dc}	
Capacitance Tolerance	±20% (M) (at 20°C, 120Hz)	
Leakage Current	I=0.01CV or 3μA, whichever is greater. Where, I : Max. leakage current (μA), C : Nominal capacitance (μF), V : Rated voltage (V) (at 20°C after 2 minutes)	
Dissipation Factor (tanδ)	Rated voltage (V _{dc})	6.3V 10V 16V 25V 35V 50V
	tanδ (Max.)	0.27 0.23 0.19 0.15 0.13 0.11
	Add 0.02 for φ3 products. (at 20°C, 120Hz)	
Low Temperature Characteristics (Max. Impedance Ratio)	Rated voltage (V _{dc})	6.3V 10V 16V 25V 35V 50V
	Z(-25°C)/Z(+20°C)	3 3 2 2 2 2
	Z(-40°C)/Z(+20°C)	9 7 5 3 3 3 (at 120Hz)
Endurance	The following specifications shall be satisfied when the capacitors are restored to 20°C after the rated voltage is applied for 1000 hours at 105°C.	
	φD	φ3 & φ3.5 φ4 to φ6.3
	Capacitance change	≤±25% of the initial value ≤±20% of the initial value
	DF (tanδ)	≤200% of the initial specified value ≤200% of the initial specified value
	Leakage current	≤The initial specified value ≤The initial specified value
Shelf Life	The following specifications shall be satisfied when the capacitors are restored to 20°C after exposing them for 500 hours at 105°C without voltage applied.	
	φD	φ3 & φ3.5 φ4 to φ6.3
	Capacitance change	≤±25% of the initial value ≤±20% of the initial value
	DF (tanδ)	≤200% of the initial specified value ≤200% of the initial specified value
	Leakage current	≤The initial specified value ≤The initial specified value

◆ DIMENSIONS (Radial Lead Type=VB) [mm]

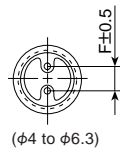
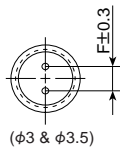
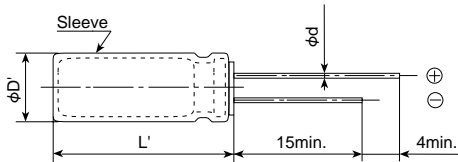

φD	3	3.5	4	5	6.3
φd	0.4	0.4	0.45	0.45	0.45
F	1.0	1.0	1.5	2.0	2.5
φD'	φD+0.5max.				
L'	L+1.0max.				

◆ PART NUMBERING SYSTEM

KRE 16 VB 47 M

Cap tolerance (±20%)
Nominal cap code
Radial lead type
Rated voltage in volts
Series name

Capacitance	Code
0.1μF	R1
0.47μF	R47
1.0μF	1
4.7μF	4R7
10μF	10
100μF	100

◆ STANDARD RATINGS

μF	V _{dc}	6.3		10		16		25		35		50	
		Case size φD×L (mm)	Rated ripple current (mA _{rms}) at 105°C, 120Hz	Case size φD×L (mm)	Rated ripple current (mA _{rms}) at 105°C, 120Hz	Case size φD×L (mm)	Rated ripple current (mA _{rms}) at 105°C, 120Hz	Case size φD×L (mm)	Rated ripple current (mA _{rms}) at 105°C, 120Hz	Case size φD×L (mm)	Rated ripple current (mA _{rms}) at 105°C, 120Hz	Case size φD×L (mm)	Rated ripple current (mA _{rms}) at 105°C, 120Hz
0.1												3×5	1.3
0.15												3×5	2.0
0.22												3×5	2.6
0.33												3×5	3.2
0.47												3×5	3.8
0.68												3×5	4.6
1.0												3×5	5.6
1.5												3×5	6.9
2.2												3×5	6.9
3.3												3×5	7.7
4.7												3.5×5	10
6.8												4×5	14
10												5×5	19
15												5×5	24
22												6.3×5	29
33												6.3×5	33
47												6.3×5	40
68												6.3×5	45
100												6.3×5	56

Note1 : → Use next higher voltage part.
Note2 : The parts of φ3.5×5 will be unified to φ4×5.

SRA Series

- Coating case covered products are also available
- 7mm height, 1000-hour-life at 85°C
- Non solvent-proof

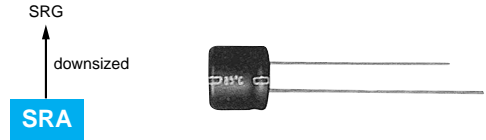

SPECIFICATIONS

Items	Characteristics									
Category	-40 to +85°C									
Temperature Range										
Rated Voltage Range	4 to 63V _{dc}									
Capacitance Tolerance	±20% (M) (at 20°C, 120Hz)									
Leakage Current	I = 0.01CV or 3μA, whichever is greater. (at 20°C after 2 minutes)									
	Where, I : Max. leakage current (μA), C : Nominal capacitance (μF), V : Rated voltage (V)									
Dissipation Factor (tanδ)	Rated voltage (V _{dc})	4V	6.3V	10V	16V	25V	35V	50V	63V	
	tanδ (Max.)	0.35	0.24	0.20	0.16	0.14	0.12	0.10	0.08	(at 20°C, 120Hz)
Low Temperature Characteristics (Max. Impedance Ratio)	Rated voltage (V _{dc})	4V	6.3V	10V	16V	25V	35V	50V	63V	
	Z(-25°C)/Z(+20°C)	4	4	3	2	2	2	2	2	(at 120Hz)
	Z(-40°C)/Z(+20°C)	10	10	8	6	4	3	3	3	
Endurance	The following specifications shall be satisfied when the capacitors are restored to 20°C after the rated voltage is applied for 1000 hours at 85°C.									
	Capacitance change	≤±20% of the initial value								
	DF (tanδ)	≤200% of the initial specified value								
	Leakage current	≤The initial specified value								
Shelf Life	The following specifications shall be satisfied when the capacitors are restored to 20°C after exposing them for 500 hours at 85°C without voltage applied.									
	Capacitance change	≤±20% of the initial value								
	DF (tanδ)	≤200% of the initial specified value								
	Leakage current	≤The initial specified value								

DIMENSIONS (Radial Lead Type=VB) [mm]

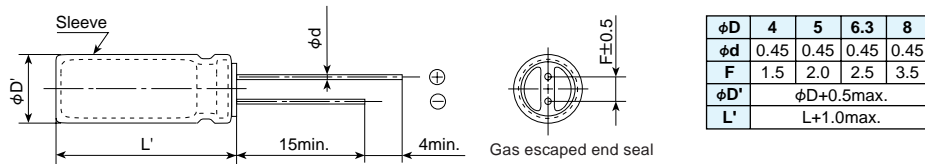

PART NUMBERING SYSTEM

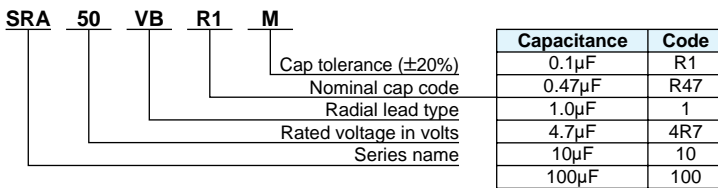

STANDARD RATINGS

μF \ V _{dc}	4	6.3	10	16	25	35	50	63
0.1							4×7 1.3	4×7 1.3
0.22							4×7 2.9	4×7 2.9
0.33							4×7 3.5	4×7 4.4
0.47							4×7 5.0	4×7 7.9
1.0							4×7 10	4×7 11
2.2							4×7 15	4×7 17
3.3							4×7 18	5×7 21
4.7							5×7 23	6.3×7 26
10		4×7 31		4×7 25			5×7 30	6.3×7 34
22				5×7 39			6.3×7 47	6.3×7 57
33	4×7 26						6.3×7 64	8×7 76
47	4×7 34	5×7 47			6.3×7 59	6.3×7 71	8×7 83	
100	5×7 61		6.3×7 80	6.3×7 97				
220	6.3×7 95		8×7 140					
330		8×7 156						
470	8×7 154							

Case size φD×L (mm)
Rated ripple current (mA_{rms}) at 85°C, 120Hz

Note : → Use next higher voltage part.

KMA Series

- Coating case covered products are also available
- 7mm height, 1000-hour-life at 105°C
- Solvent-proof type, see page 16

KMA

105°C
SRA



SPECIFICATIONS

Items	Characteristics	
Category	-55 to +105°C	
Temperature Range	-55 to +105°C	
Rated Voltage Range	4 to 63V _{dc}	
Capacitance Tolerance	±20% (M)	
Leakage Current	I = 0.01CV or 3μA, whichever is greater. (at 20°C, 120Hz) Where, I : Max. leakage current (μA), C : Nominal capacitance (μF), V : Rated voltage (V) (at 20°C after 2 minutes)	
Dissipation Factor (tanδ)	Rated voltage (V _{dc})	4V 6.3V 10V 16V 25V 35V 50V 63V
	tanδ (Max.)	0.35 0.22 0.19 0.16 0.14 0.12 0.10 0.08 (at 20°C, 120Hz)
Low Temperature Characteristics (Max. Impedance Ratio)	Rated voltage (V _{dc})	4V 6.3V 10V 16V 25V 35V 50V 63V
	Z(-25°C)/Z(+20°C)	4 3 2 2 2 2 2 2 (at 120Hz)
	Z(-40°C)/Z(+20°C)	10 6 5 3 3 3 3 3
Endurance	The following specifications shall be satisfied when the capacitors are restored to 20°C after the rated voltage is applied for 1000 hours at 105°C.	
	Rated voltage	4 to 16V _{dc} 25 to 63V _{dc}
	Capacitance change	≤±25% of the initial value ≤±20% of the initial value
	DF (tanδ)	≤200% of the initial specified value
	Leakage current	≤The initial specified value
Shelf Life	The following specifications shall be satisfied when the capacitors are restored to 20°C after exposing them for 1000 hours at 105°C without voltage applied.	
	Rated voltage	4 to 16V _{dc} 25 to 63V _{dc}
	Capacitance change	≤±25% of the initial value ≤±20% of the initial value
	DF (tanδ)	≤200% of the initial specified value
	Leakage current	≤The initial specified value

DIMENSIONS (Radial Lead Type=VB) [mm]

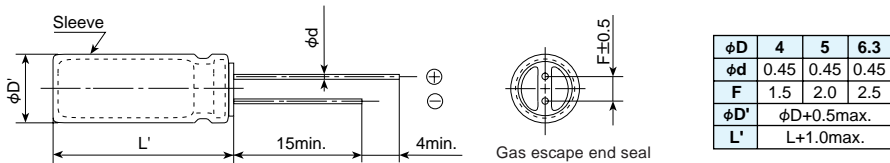

PART NUMBERING SYSTEM

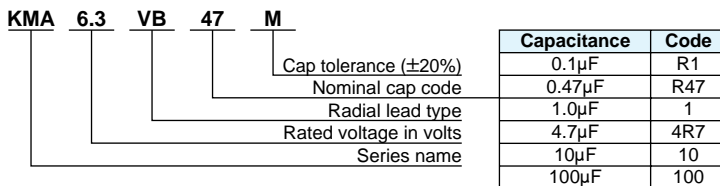

STANDARD RATINGS

μF \ V _{dc}	4	6.3	10	16	25	35	50	63
0.1							4X7 1.3	4X7 1.3
0.15							4X7 2.0	4X7 1.9
0.22							4X7 2.9	4X7 2.9
0.33							4X7 3.5	4X7 4.4
0.47							4X7 5.0	4X7 7.9
0.68							4X7 7.1	4X7 9.2
1.0							4X7 10	4X7 11
1.5							4X7 12	4X7 13
2.2							4X7 15	4X7 17
3.3							4X7 18	5X7 21
4.7						4X7 20	5X7 23	6.3X7 26
6.8				4X7 20		5X7 24	6.3X7 28	
10				4X7 25		5X7 30	6.3X7 34	6.3X7 43
15				4X7 31		6.3X7 37		
22		4X7 31		5X7 39		6.3X7 47	6.3X7 57	
33	4X7 26		5X7 43		6.3X7 53	6.3X7 64		
47	4X7 34	5X7 47		6.3X7 59	6.3X7 71			
68			6.3X7 63					
100	5X7 61		6.3X7 80	6.3X7 97				
220	6.3X7 95							

Note: → Use next higher voltage part.

SRG Series

- Low Profile : $\phi 4 \times 7\text{mm}$ to $\phi 18 \times 25\text{mm}$
- Endurance : 85°C 1000 to 2000 hours
- Solvent-proof type, see page 16

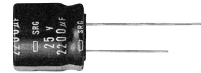
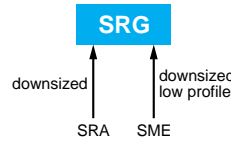

◆ SPECIFICATIONS

Items	Characteristics							
Category	-40 to +85°C							
Temperature Range								
Rated Voltage Range	4 to 50V _{dc}							
Capacitance Tolerance	±20% (M) (at 20°C, 120Hz)							
Leakage Current	I = 0.01CV or 3μA, whichever is greater. Where, I : Max. leakage current (μA), C : Nominal capacitance (μF), V : Rated voltage (V) (at 20°C after 2 minutes)							
Dissipation Factor (tanδ)	Rated voltage (V _{dc})	4V	6.3V	10V	16V	25V	35V	50V
	tanδ (Max.)	0.38	0.28	0.24	0.20	0.16	0.14	0.12
	When nominal capacitance exceeds 1000μF, add 0.03 to the value above for each 1000μF increase. (at 20°C, 120Hz)							
Low Temperature Characteristics (Max. Impedance Ratio)	Rated voltage (V _{dc})	4V	6.3V	10V	16V	25V	35V	50V
	Z(-25°C)/Z(+20°C)	6	5	4	3	2	2	2
	Z(-40°C)/Z(+20°C)	12	12	10	8	5	4	3
Endurance	The following specifications shall be satisfied when the capacitors are restored to 20°C after the rated voltage is applied for 2000 hours (1000 hours for $\phi 8$ and smaller) at 85°C.							
	Capacitance change	≤±20% of the initial value						
	DF (tanδ)	≤200% of the initial specified value						
	Leakage current	≤The initial specified value						
Shelf Life	The following specifications shall be satisfied when the capacitors are restored to 20°C after exposing them for 1000 hours at 85°C without voltage applied.							
	Capacitance change	≤±20% of the initial value						
	DF (tanδ)	≤200% of the initial specified value						
	Leakage current	≤The initial specified value						

◆ DIMENSIONS (Radial Lead Type=VB) [mm]

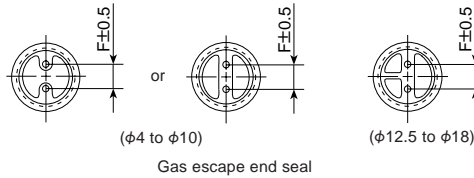
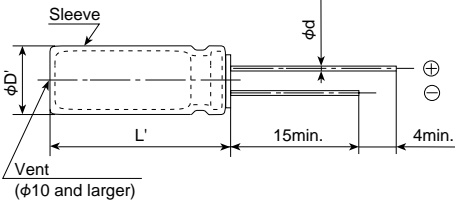

φD	4	5	6.3	8	10 & 12.5	16 & 18
7L	0.45	0.45	0.45	0.45	—	—
φd	≥9L	—	0.5	0.5	0.6	0.6
F	1.5	2.0	2.5	3.5	5.0	7.5
φD'	φD+0.5max.					
L'	L+1.5max. (7L : L+1.0max.)					

◆ PART NUMBERING SYSTEM

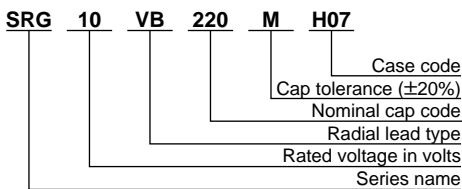

Capacitance	Code
0.1μF	R1
0.47μF	R47
1.0μF	1
4.7μF	4R7
10μF	10
100μF	100

◆ CASE CODE

φD (mm) \ L (mm)	7	9	12.5	13	15	20	25
4	D07						
5	E07	E09					
6.3	F07	F09					
8	H07	H09					
10		J09	J12				
12.5				K13	K15		
16					L15		
18					M15	M20	M25

SRG Series 9 to 25mm-length
◆STANDARD RATINGS

μF \ V_{dc}	6.3		10		16		25		35		50	
1.0											5×9	13
2.2											5×9	26
3.3											5×9	32
4.7											5×9	38
10											5×9	64
22											5×9	86
33									5×9	94	6.3×9	113
47							5×9	105			6.3×9	135
100			5×9	132			6.3×9	172	8×9	220	10×9	240
220			6.3×9	218	8×9	290			10×9	335	10×12.5	415
330	6.3×9	247			8×9	355	10×9	380	10×12.5	475	12.5×13	525
470			8×9	385	10×9	410	10×12.5	525	12.5×13	585	16×15	745
1,000	10×9	505	10×12.5	625	12.5×13	715	12.5×15	830	16×15	1,010	18×20	1,160
2,200			12.5×15	970	16×15	1,160	18×15	1,360	18×20	1,560		
3,300			16×15	1,310	18×15	1,460	18×20	1,720				
4,700	16×15	1,410	18×15	1,560	18×20	1,770	18×25	2,070				
6,800	18×15	1,660	18×20	1,870	18×25	2,170						
10,000	18×20	2,020	18×25	2,370								

Rated ripple current (mAmps) at 85°C, 120Hz
 Case size ϕ D×L (mm)

Note : → Use next higher voltage part.

SRG Series 7mm-length
◆STANDARD RATINGS

μF \ V_{dc}	4		6.3		10		16		25		35		50	
0.1													4×7	1.3
0.22													4×7	2.9
0.33													4×7	3.5
0.47													4×7	5.0
1.0													4×7	10
2.2													4×7	15
3.3													4×7	19
4.7													4×7	24
10											4×7	32	5×7	42
22						4×7	42				5×7	57	6.3×7	64
33					4×7	46			5×7	66	6.3×7	73	8×7	93
47			4×7	50			5×7	73	6.3×7	80	8×7	101		
100			5×7	87			6.3×7	110						
220			6.3×7	133	8×7	171								
330			8×7	191										
470	8×7	154												

Rated ripple current (mAmps) at 85°C, 120Hz
 Case size ϕ D×L (mm)

Note : → Use next higher voltage part.

◆RATED RIPPLE CURRENT MULTIPLIERS

●Frequency Multipliers

Capacitance (μF) \ Frequency (Hz)	50	120	300	1k	10k	100k
to 4.7	0.65	1.00	1.35	1.75	2.30	2.50
10 to 47	0.75	1.00	1.25	1.50	1.75	1.80
100 to 1,000	0.80	1.00	1.15	1.30	1.40	1.50
2,200 to	0.85	1.00	1.03	1.05	1.08	1.08

KRG Series

- Low profile : $\phi 4 \times 7\text{mm}$ to $\phi 18 \times 25\text{mm}$
- Endurance : 105°C 1000 hours
- Solvent-proof type, see page 16

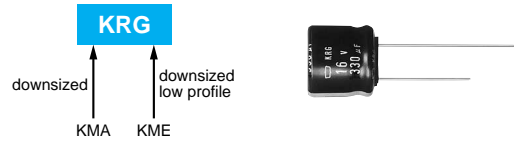

SPECIFICATIONS

Items	Characteristics	
Category	-55 to +105°C	
Temperature Range	-55 to +105°C	
Rated Voltage Range	6.3 to 50V _{dc}	
Capacitance Tolerance	±20% (M) (at 20°C, 120Hz)	
Leakage Current	I=0.01CV or 3µA, whichever is greater. Where, I : Max. leakage current (µA), C : Nominal capacitance (µF), V : Rated voltage (V) (at 20°C after 2 minutes)	
Dissipation Factor (tanδ)	Rated voltage (V _{dc})	6.3V 10V 16V 25V 35V 50V
	tanδ (Max.)	0.28 0.24 0.20 0.16 0.14 0.12
	When nominal capacitance exceeds 1000µF, add 0.03 to the value above for each 1000µF increase. (at 20°C, 120Hz)	
Low Temperature Characteristics (Max. Impedance Ratio)	Rated voltage (V _{dc})	6.3V 10V 16V 25V 35V 50V
	Z(-25°C)/Z(+20°C)	5 4 3 2 2 2
	Z(-40°C)/Z(+20°C)	10 8 6 4 3 3
	(at 120Hz)	
Endurance	The following specifications shall be satisfied when the capacitors are restored to 20°C after the rated voltage is applied for 1000 hours at 105°C.	
	Rated voltage	6.3 to 16V _{dc} 25 to 50V _{dc}
	Capacitance change	≤±25% of the initial value ≤±20% of the initial value
	DF (tanδ)	≤200% of the initial specified value ≤200% of the initial specified value
	Leakage current	≤The initial specified value ≤The initial specified value
Shelf Life	The following specifications shall be satisfied when the capacitors are restored to 20°C after exposing them for 500 hours at 105°C without voltage applied.	
	Rated voltage	6.3 to 16V _{dc} 25 to 50V _{dc}
	Capacitance change	≤±25% of the initial value ≤±20% of the initial value
	DF (tanδ)	≤200% of the initial specified value ≤200% of the initial specified value
	Leakage current	≤The initial specified value ≤The initial specified value

DIMENSIONS (Radial Lead Type=VB) [mm]

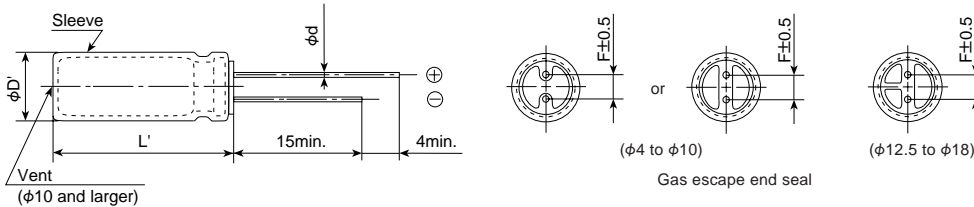

φD	4	5	6.3	7	8	10 & 12.5	16 & 18
7L	0.45	0.45	0.45	0.45	-	-	-
φd	≥9L	0.5	0.5	-	0.6	0.6	0.8
F	1.5	2.0	2.5	2.5	3.5	5.0	7.5
φD*	φD+0.5max.						
L'	L+1.5max. (7L : L+1.0max.)						

PART NUMBERING SYSTEM

KRG 6.3 VB 1000 M J09

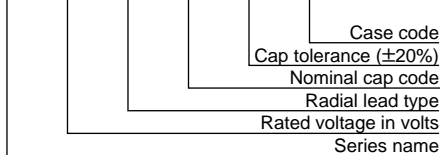

Capacitance	Code
0.1µF	R1
0.47µF	R47
1.0µF	1
4.7µF	4R7
10µF	10
100µF	100

CASE CODE

φD (mm)	L (mm)	7	9	12.5	13	15	20	25
4		D07						
5		E07	E09					
6.3		F07	F09					
7		G07						
8			H09					
10			J09	J12				
12.5					K13	K15		
16						L15		
18						M15	M20	M25

KRG Series 9 to 25mm-length
◆STANDARD RATINGS

$\mu\text{F} \backslash V_{\text{dc}}$	6.3	10	16	25	35	50
1.0						5×9 12
2.2						5×9 18
3.3						5×9 22
4.7						5×9 27
10						5×9 46
22						5×9 61
33					5×9 67	6.3×9 80
47				5×9 75		6.3×9 95
100		5×9 93		6.3×9 121	8×9 155	10×9 170
220		6.3×9 154	8×9 205		10×9 235	10×12.5 290
330	6.3×9 175		8×9 251	10×9 270	10×12.5 340	12.5×13 370
470		8×9 272	10×9 290	10×12.5 370	12.5×13 415	16×15 535
1,000	10×9 365	10×12.5 445	12.5×13 515	12.5×15 590	16×15 720	18×20 830
2,200		12.5×15 690	16×15 830	18×15 970	18×20 1,110	
3,300		16×15 940	18×15 1,050	18×20 1,220		
4,700	16×15 1,010	18×15 1,120	18×20 1,260	18×25 1,470		
6,800	18×15 1,190	18×20 1,330	18×25 1,560			
10,000	18×20 1,440	18×25 1,700				

Note : → Use next higher voltage part.

KRG Series 7mm-length
◆STANDARD RATINGS

$\mu\text{F} \backslash V_{\text{dc}}$	6.3	10	16	25	35	50
0.1						4×7 1.3
0.22						4×7 2.9
0.33						4×7 3.5
0.47						4×7 5
1.0						4×7 10
2.2						4×7 15
3.3						4×7 18
4.7						4×7 25
10				4×7 30	5×7 36	6.3×7 44
22		4×7 35		5×7 46	6.3×7 57	6.3×7 57
33			5×7 53	6.3×7 63	6.3×7 64	
47	5×7 50		6.3×7 68	6.3×7 71		
100		6.3×7 80	6.3×7 97			

Note : → Use next higher voltage part.

◆RATED RIPPLE CURRENT MULTIPLIERS

●Frequency Multipliers

Capacitance (μF) \ Frequency (Hz)	50	120	300	1k	10k	100k
0.1 to 4.7	0.65	1.00	1.35	1.75	2.30	2.50
10 to 47	0.75	1.00	1.25	1.50	1.75	1.80
100 to 1,000	0.80	1.00	1.15	1.30	1.40	1.50
2,200 to	0.85	1.00	1.03	1.05	1.08	1.08

SMG Series

- Downsized from current standard SME series
- Endurance : 85°C 2000 hours
- Solvent-proof type, except 350 to 450V_{dc}, see page 16



◆ SPECIFICATIONS

Items	Characteristics																
Category	-40 to +85°C(6.3 to 400V _{dc}) -25 to +85°C(450V _{dc})																
Temperature Range																	
Rated Voltage Range	6.3 to 450V _{dc}																
Capacitance Tolerance	±20% (M) (at 20°C, 120Hz)																
Leakage Current	6.3 to 100V _{dc}						160 to 450V _{dc}										
	≤φ18	I=0.03CV or 4µA, whichever is greater.						CV	Time	After 1minute			After 5minutes				
										CV≤1000			I=0.1CV+40			I=0.03CV+15	
								CV>1000			I=0.04CV+100			I=0.02CV+25			
	(at 20C after 1 minute)						(at 20°C)										
≥φ20	I=0.03CV						(at 20°C after 3 minutes)										
Where, I : Max. leakage current (µA), C : Nominal capacitance (µF), V : Rated voltage (V)																	
Dissipation Factor (tanδ)	Rated voltage (V _{dc})																
			6.3V	10V	16V	25V	35V	50V	63V	100V	160 to 250V	315 to 400V	450V				
	tanδ (Max.)		≤φ18	0.34	0.24	0.20	0.16	0.14	0.12	0.09	0.08	0.20	0.24	0.24			
		≥φ20	0.28	0.24	0.20	0.16	0.14	0.12	0.09	0.08	0.15	0.15	0.20				
When nominal capacitance exceeds 1000µF, add 0.02 to the value above for each 1000µF increase. (at 20°C, 120Hz)																	
Low Temperature Characteristics (Max. Impedance Ratio)	Rated voltage (V _{dc})																
			6.3V	10V	16V	25V	35V	50V	63V	100V	160 to 250V	315 to 400V	450V				
	Z(-25°C)/Z(+20°C)		≤φ18	5	4	3	2	2	2	2	2	3	6	6			
		≥φ20	5	4	3	2	2	2	2	2	4	6	6				
Z(-40°C)/Z(+20°C)		≤φ18	12	10	8	5	4	3	3	3	4	6	—				
(at 120Hz)																	
Endurance	The following specifications shall be satisfied when the capacitors are restored to 20°C after the rated voltage is applied for 2000 hours at 85°C.																
	Capacitance change		≤±20% of the initial value														
	DF (tanδ)		≤200% of the initial specified value														
	Leakage current		≤The initial specified value														
Shelf Life	The following specifications shall be satisfied when the capacitors are restored to 20°C after exposing them for 1000 hours at 85°C without voltage applied.																
	Rated voltage						6.3 to 100V _{dc}							160 to 450V _{dc}			
	Capacitance change						≤±20% of the initial value							≤±20% of the initial value			
	DF (tanδ)						≤200% of the initial specified value							≤200% of the initial specified value			
	Leakage current						≤The initial specified value							≤500% of the initial specified value			

◆ PART NUMBERING SYSTEM

SMG 6.3 VB 1000 M

Capacitance	Code
0.1µF	R1
0.47µF	R47
1.0µF	1
4.7µF	4R7
10µF	10
100µF	100

◆ CASE CODE [mm]

Case code	Case size φDXL	Case code	Case size φDXL	Case code	Case size φDXL
20S	20×20	—	—	—	—
20A	20×25	—	—	—	—
20B	20×30	22B	22×30	—	—
20C	20×35	22C	22×35	—	—
20D	20×40	22D	22×40	25D	25.4×40

◆ DIMENSIONS (Radial Lead Type=VB) [mm]

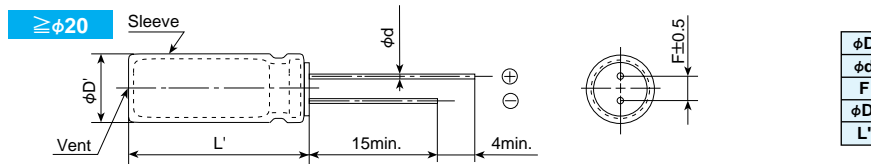
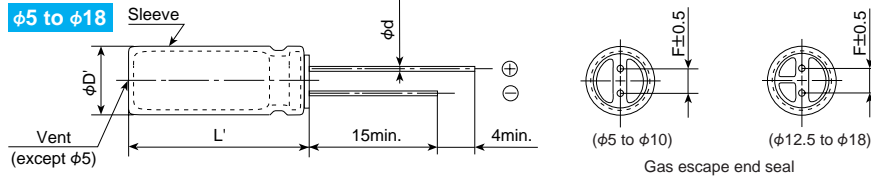

φD	5	6.3	8	10	12.5	16	18	20	22	25.4
φd	0.5	0.5	0.6	0.6	0.6	0.8	0.8	1.0	1.0	1.0
F	2.0	2.5	3.5	5.0	5.0	7.5	7.5	10.0	10.0	12.5
φD'	φD+0.5max.							φD+0.5max.		
L'	L+1.5max.							L+2.0max.		

◆ RATED RIPPLE CURRENT MULTIPLIERS

● Frequency Multipliers

(φ5 to φ18)

Capacitance (μF)	Frequency (Hz)					
	50	120	300	1k	10k	100k
0.1 to 4.7	0.65	1.00	1.35	1.75	2.30	2.50
10 to 47	0.75	1.00	1.25	1.50	1.75	1.80
100 to 1,000	0.80	1.00	1.15	1.30	1.40	1.50
2,200 to	0.85	1.00	1.03	1.05	1.08	1.08

(φ20 to φ25.4)

Rated Voltage (V _{DC})	Frequency (Hz)					
	50	120	300	1k	10k	100k
6.3 to 50	0.95	1.00	1.03	1.05	1.08	1.08
63 to 100	0.92	1.00	1.07	1.13	1.19	1.20
160 to 250	0.81	1.00	1.17	1.32	1.45	1.50
315 to 450	0.77	1.00	1.16	1.30	1.41	1.43



SMG Series

◆STANDARD RATINGS

μF \ V _{dc}	6.3		10		16		25		35		50		63		100		
0.1											5×11	1.3			5×11	2.1	
0.22											5×11	2.9			5×11	4.7	
0.33											5×11	4.3			5×11	7	
0.47											5×11	6.2			5×11	10	
1.0											5×11	17			5×11	21	
2.2											5×11	28			5×11	30	
3.3											5×11	35			5×11	40	
4.7											5×11	41			5×11	45	
10											5×11	60	5×11	65	6.3×11	75	
22											5×11	95	5×11	100	8×11.5	130	
33											5×11	125	6.3×11	140	8×11.5	180	
47							5×11	115	5×11	130	6.3×11	155	6.3×11	170	10×12.5	230	
100					5×11	160	6.3×11	190	6.3×11	210	8×11.5	260	10×12.5	300	10×20	370	
220	5×11	200	5×11	240	6.3×11	260	8×11.5	330	8×11.5	385	10×12.5	430	10×16	490	12.5×25	620	
330	6.3×11	270	6.3×11	290	8×11.5	370	8×11.5	440	10×12.5	490	10×16	585	10×20	710	12.5×25	760	
470	6.3×11	320	6.3×11	350	8×11.5	440	10×12.5	545	10×16	645	10×20	755	12.5×20	900	16×25	1,000	
680															20×30	1,360	
820														20×20	1,370	22×30	1,540
1,000	8×11.5	540	10×12.5	650	10×16	785	10×20	955	12.5×20	1,145	12.5×25	1,340	16×25	1,300	18×40	1,380	
1,200															20×35	1,720	
1,500											20×20	1,570	20×30	1,850	22×40	1,980	
1,800															25.4×40	2,490	
2,200	10×20	1,000	10×20	1,070	12.5×20	1,295	12.5×25	1,540	16×25	1,785	16×35.5	2,075	20×35	2,330			
2,700									20×20	1,670	20×25	1,880	22×30	2,190			
3,300	10×20	1,185	12.5×20	1,420	12.5×25	1,655	16×25	1,975	16×35.5	2,275	18×35.5	2,500					
3,900									20×20	1,850	20×25	2,050	20×35	2,420	22×40	2,810	
4,700	12.5×20	1,545	12.5×25	1,780	16×25	2,090	16×31.5	2,420	18×35.5	2,700							
5,600							20×30	2,430	20×40	2,690	22×30	2,420	22×40	2,810			
6,800	12.5×25	1,915	16×25	2,220	16×31.5	2,520	18×35.5	2,880	22×30	2,380	22×40	2,960					
8,200					20×20	2,080	20×25	2,330	20×35	2,680	22×40	3,090	25.4×40	3,360			
10,000	16×25	2,330	16×35.5	2,670	18×35.5	2,920			20×30	2,430	20×40	2,690					
12,000	20×25	2,310	20×25	2,410	20×35	2,720	22×30	2,660	22×40	3,240	25.4×40	3,480					
15,000			20×30	2,620	20×40	2,900	22×35	2,900	22×40	3,240							
18,000	16×35.5	2,845	18×35.5	3,080													
22,000	20×30	2,660	20×35	2,870													
27,000			22×30	2,660	22×40	3,380	25.4×40	3,610									
33,000	20×35	2,890															
39,000	22×30	2,860	22×35	3,050													
	18×40	3,320															
	20×40	3,130															
	22×35	3,130	22×40	3,480	25.4×40	3,720											
	22×40	3,280															
			25.4×40	3,560													
	25.4×40	3,560															



SMG Series

◆STANDARD RATINGS

μF	V _{dc}	Non solvent-proof																	
		160		200		250		315		350		400		450					
0.47		Case size φD×L (mm)												6.3×11	15			10×12.5	13
1.0		Rated ripple current (mA _{rms}) at 85°C, 120Hz												6.3×11	22	6.3×11	22	10×12.5	19
2.2						6.3×11	32					8×11.5	38	8×11.5	38	10×12.5	32		
3.3		6.3×11	40	6.3×11	40	8×11.5	46					8×11.5	46	10×12.5	54	10×16	44		
4.7		6.3×11	48	8×11.5	55	8×11.5	55					10×12.5	65	10×16	71	10×20	56		
10		10×12.5	94	10×12.5	94	10×16	105					10×20	115	10×20	115	12.5×20	91		
22		10×20	170	10×20	170	10×20	170					12.5×20	185	12.5×25	205	16×25	165		
33		10×20	205	10×20	205	12.5×20	230					16×25	275	16×25	275	16×31.5	215		
													20×20	260	20×25	240			
47		12.5×20	270	12.5×20	270	12.5×25	295	20×20	310	16×25	325	16×31.5	350	16×35.5	265				
									20×20	310			20×25	290					
56												20×25	350	20×30	320				
68								20×25	400	20×25	400	20×30	420	20×35	370				
														22×30	370				
82						20×20	420	20×25	440					20×40	420				
														22×35	420				
100		12.5×25	430	16×25	475	16×31.5	515			18×31.5	530								
				20×20	460	20×25	490	20×30	500	20×30	500	20×35	520	22×40	470				
120						20×25	530	20×30	550	20×35	560	20×40	580	25.4×40	520				
												22×35	580						
180				20×25	660	20×30	680	20×40	720			25.4×40	790						
								22×35	720										
220		16×31.5	760	20×30	750	20×35	780	22×40	810	25.4×40	890								
		20×25	730	18×35.5	810	22×30	820												
270				20×30	830	20×40	880	25.4×40	920										
						22×35	880												
330		18×35.5	995	20×35	1,070	22×40	1,060												
		20×30	920	22×30	1,070														
390		20×35	1,160	20×40	1,190	25.4×40	1,200												
		22×30	1,160	22×30	1,160														
470		20×40	1,340	22×40	1,350														
		22×35	1,340																
560		22×40	1,470	22×40	1,430														
680		25.4×40	1,570	25.4×40	1,620														

KMG Series

- Downsized from current standard KME series
- Solvent-proof type, except 350 to 450V_{dc}, see page 16

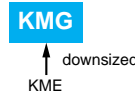

SPECIFICATIONS

Items	Characteristics																							
Category	-55 to +105°C(6.3 to 100V _{dc}) -40 to +105°C(160 to 400V _{dc}) -25 to +105°C(450V _{dc})																							
Temperature Range																								
Rated Voltage Range	6.3 to 450V _{dc}																							
Capacitance Tolerance	±20% (M) (at 20°C, 120Hz)																							
Leakage Current	6.3 to 100V _{dc}																							
	I=0.03CV or 4μA, whichever is greater.																							
	160 to 450V _{dc}																							
	<table border="1"> <thead> <tr> <th>CV</th> <th>Time</th> <th>After 1minute</th> <th>After 5minutes</th> </tr> </thead> <tbody> <tr> <td>CV≤1000</td> <td></td> <td>I=0.1CV+40</td> <td>I=0.03CV+15</td> </tr> <tr> <td>CV>1000</td> <td></td> <td>I=0.04CV+100</td> <td>I=0.02CV+25</td> </tr> </tbody> </table>													CV	Time	After 1minute	After 5minutes	CV≤1000		I=0.1CV+40	I=0.03CV+15	CV>1000		I=0.04CV+100
CV	Time	After 1minute	After 5minutes																					
CV≤1000		I=0.1CV+40	I=0.03CV+15																					
CV>1000		I=0.04CV+100	I=0.02CV+25																					
(at 20°C after 1 minute) (at 20°C)																								
Where, I : Max. leakage current (μA), C : Nominal capacitance (μF), V : Rated voltage (V)																								
Dissipation Factor (tanδ)	Rated voltage (V _{dc})	6.3V	10V	16V	25V	35V	50V	63V	100V	160 to 250V	350 to 400V	450V												
	tanδ (Max.)	0.34	0.24	0.20	0.16	0.14	0.12	0.10	0.08	0.20	0.24	0.24												
	When nominal capacitance exceeds 1000μF, add 0.02 to the value above for each 1000μF increase. (at 20°C, 120Hz)																							
Low Temperature Characteristics (Max. Impedance Ratio)	Rated voltage (V _{dc})	6.3V	10V	16V	25V	35V	50V	63V	100V	160 to 250V	350 to 400V	450V												
	Z(-25°C)/Z(+20°C)	5	4	3	2	2	2	2	2	3	6	6												
	Z(-40°C)/Z(+20°C)	12	10	8	5	4	3	3	3	4	6	6												
(at 120Hz)																								
Endurance	The following specifications shall be satisfied when the capacitors are restored to 20°C after subjected to DC voltage with the rated ripple current is applied for 1000 hours (2000 hours to meet the following two conditions 1) : 160V _{dc} and larger, 2) : φ12.5 and larger) at 105°C.																							
	Capacitance change	≤±20% of the initial value																						
	DF (tanδ)	≤200% of the initial specified value																						
	Leakage current	≤The initial specified value																						
Shelf Life	The following specifications shall be satisfied when the capacitors are restored to 20°C after exposing them for 1000 hours at 105°C without voltage applied.																							
	Rated voltage	6.3 to 100V _{dc}						160 to 450V _{dc}																
	Capacitance change	≤±20% of the initial value						≤±20% of the initial value																
	DF (tanδ)	≤200% of the initial specified value						≤200% of the initial specified value																
	Leakage current	≤The initial specified value						≤500% of the initial specified value																

DIMENSIONS (Radial Lead Type=VB) [mm]

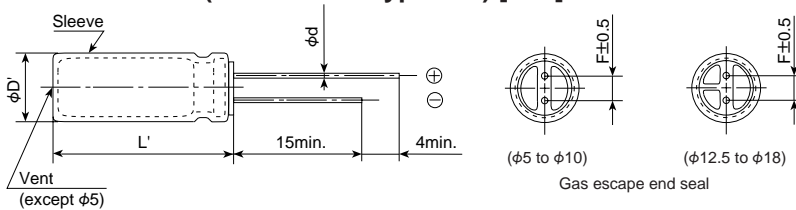

φD	5	6.3	8	10	12.5	16	18
φd	0.5	0.5	0.6	0.6	0.6	0.8	0.8
F	2.0	2.5	3.5	5.0	5.0	7.5	7.5
φD'	φD+0.5max.						
L'	L+1.5max						

PART NUMBERING SYSTEM

Capacitance	Code
0.1μF	R1
0.47μF	R47
1.0μF	1
4.7μF	4R7
10μF	10
100μF	100

KMG 6.3 VB 1000 M
 KMG: Series name
 6.3: Rated voltage in volts
 VB: Radial lead type
 1000: Nominal capacitance code
 M: Capacitance tolerance (±20%)



KMG Series

◆STANDARD RATINGS

μF \ V _{dc}	6.3		10		16		25		35		50		63		100		
0.1											5X11	1.3			5X11	1.5	
0.22											5X11	2.9			5X11	3.4	
0.33											5X11	4.3			5X11	5.0	
0.47											5X11	6.2			5X11	7.1	
1.0											5X11	13			5X11	15	
2.2											5X11	20			5X11	21	
3.3											5X11	25			5X11	29	
4.7											5X11	30			5X11	32	
10											5X11	40	5X11	46	6.3X11	54	
22											5X11	65	5X11	71	8X11.5	93	
33											5X11	90	6.3X11	100	8X11.5	130	
47								5X11	80	5X11	90	6.3X11	110	6.3X11	120	10X12.5	165
100					5X11	110	6.3X11	130	6.3X11	150	8X11.5	180	10X12.5	215	10X20	265	
220	5X11	140	6.3X11	170	6.3X11	180	8X11.5	230	8X11.5	270	10X12.5	300	10X16	335	12.5X25	440	
330	6.3X11	190	6.3X11	200	8X11.5	260	8X11.5	310	10X12.5	350	10X16	410	10X20	510	16X25	540	
470	6.3X11	230	8X11.5	250	8X11.5	310	10X12.5	380	10X16	460	10X20	530	12.5X20	640	16X31.5	715	
1,000	8X11.5	380	10X12.5	460	10X16	560	10X20	680	12.5X20	810	12.5X25	950	16X25	930	18X40	985	
2,200	10X20	710	10X20	760	12.5X20	920	12.5X25	1,090	16X25	1,260	16X35.5	1,470					
3,300	10X20	840	12.5X20	1,000	12.5X25	1,170	16X25	1,400	16X35.5	1,610	18X35.5	1,770					
4,700	12.5X20	1,090	12.5X25	1,260	16X25	1,480	16X31.5	1,710	18X35.5	1,910							
6,800	12.5X25	1,350	16X25	1,570	16X31.5	1,780	18X35.5	2,040									
10,000	16X25	1,650	16X35.5	1,890	18X35.5	2,060											
15,000	16X35.5	2,010	18X35.5	2,180													
22,000	18X40	2,350															

Case size φD×L (mm)
Rated ripple current (mA_{rms}) at 105°C, 120Hz

		Non solvent-proof											
μF \ V _{dc}		160		200		250		350		400		450	
0.47								6.3X11	11			10X12.5	9
1.0								6.3X11	15	6.3X11	15	10X12.5	13
2.2						6.3X11	23	8X11.5	26	8X11.5	26	10X12.5	23
3.3	6.3X11	28	6.3X11	28	8X11.5	32	10X12.5	38	10X12.5	38	10X16	31	
4.7	6.3X11	34	8X11.5	39	8X11.5	39	10X16	50	10X16	50	10X20	40	
10	10X12.5	67	10X16	74	10X16	74	10X20	80	10X20	80	12.5X20	65	
22	10X20	120	10X20	120	12.5X20	130	12.5X20	130	12.5X25	145	16X25	115	
33	10X20	145	12.5X20	160	12.5X20	160	16X25	195	16X25	195	16X31.5	155	
47	12.5X20	195	12.5X20	195	12.5X25	210	16X25	230	16X31.5	250	16X35.5	185	
100	16X25	335	16X25	335	16X31.5	365	18X31.5	375	16X40	350			
220	16X31.5	540	18X35.5	575	18X40	585							
330	18X35.5	705											

◆RATED RIPPLE CURRENT MULTIPLIERS

●Frequency Multipliers

Capacitance (μF) \ Frequency (Hz)	50	120	300	1k	10k	100k
0.1 to 4.7	0.65	1.00	1.35	1.75	2.30	2.50
10 to 47	0.75	1.00	1.25	1.50	1.75	1.80
100 to 1,000	0.80	1.00	1.15	1.30	1.40	1.50
2,200 to	0.85	1.00	1.03	1.05	1.08	1.08

SME Series

- Endurance : 85°C 2000 hours
- Solvent-proof type, except 350 to 450V_{dc}, see page 16

SMG ← SME
downsized



◆ SPECIFICATIONS

Items	Characteristics																	
Category	-40 to +85°C (6.3 to 400V _{dc}) -25 to +85°C (450V _{dc})																	
Temperature Range																		
Rated Voltage Range	6.3 to 450V _{dc}																	
Capacitance Tolerance	±20% (M) (at 20°C, 120Hz)																	
Leakage Current	6.3 to 100V _{dc}						160 to 450V _{dc}											
	I=0.03CV or 4µA, whichever is greater. (at 20°C after 1 minute)						CV			Time			After 1 minute			After 5 minutes		
	I=0.01CV or 3µA, whichever is greater. (at 20°C after 2 minutes)						CV ≤ 1000			I=0.1CV+40			I=0.03CV+15					
							CV > 1000			I=0.04CV+100			I=0.02CV+25					
													(at 20°C)					
													Where, I : Max. leakage current (µA), C : Nominal capacitance (µF), V : Rated voltage (V)					
Dissipation Factor (tanδ)	Rated voltage (V _{dc})	6.3V	10V	16V	25V	35V	50V	63V	100V	160 to 250V	350 to 400V	450V						
	tanδ (Max.)	0.22	0.19	0.16	0.14	0.12	0.10	0.09	0.08	0.20	0.24	0.24						
	When nominal capacitance exceeds 1000µF, add 0.02 to the value above for each 1000µF increase. (at 20°C, 120Hz)																	
Low Temperature Characteristics (Max. Impedance Ratio)	Rated voltage (V _{dc})	6.3V	10V	16V	25V	35V	50V	63V	100V	160 to 250V	350 to 400V	450V						
	Z(-25°C)/Z(+20°C)	4	3	2	2	2	2	2	2	3	6	16						
	Z(-40°C)/Z(+20°C)	8	6	4	3	3	3	3	3	4	6	—						
													(at 120Hz)					
Endurance	The following specifications shall be satisfied when the capacitors are restored to 20°C after the rated voltage is applied for 2000 hours at 85°C.																	
	Rated voltage	6.3 to 100V _{dc}						160 to 400V _{dc}			450V _{dc}							
	Capacitance change	≤±20% of the initial value						≤±20% of the initial value			≤±20% of the initial value							
	DF (tanδ)	≤150% of the initial specified value						≤200% of the initial specified value			≤150% of the initial specified value							
	Leakage current	≤The initial specified value						≤The initial specified value			≤The initial specified value							
Shelf Life	The following specifications shall be satisfied when the capacitors are restored to 20°C after exposing them for 1000 hours at 85°C without voltage applied.																	
	Rated voltage	6.3 to 100V _{dc}						160 to 400V _{dc}			450V _{dc}							
	Capacitance change	≤±20% of the initial value						≤±20% of the initial value			≤±20% of the initial value							
	DF (tanδ)	≤150% of the initial specified value						≤200% of the initial specified value			≤200% of the initial specified value							
	Leakage current	≤The initial specified value						≤500% of the initial specified value			≤500% of the initial specified value							

◆ DIMENSIONS (Radial Lead Type=VB) [mm]

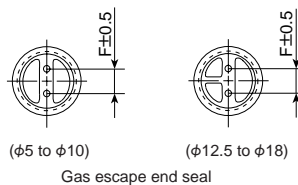
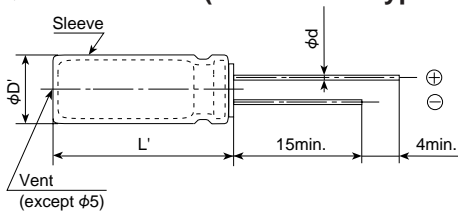

φD	5	6.3	8	10	12.5	16	18
φd	0.5	0.5	0.6	0.6	0.6	0.8	0.8
F	2.0	2.5	3.5	5.0	5.0	7.5	7.5
φD'	φD+0.5max.						
L'	L+1.5max						

◆ PART NUMBERING SYSTEM

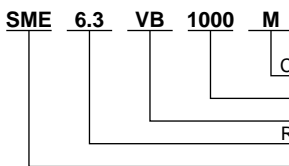

Capacitance	Code
0.1µF	R1
0.47µF	R47
1.0µF	1
4.7µF	4R7
10µF	10
100µF	100

◆ RATED RIPPLE CURRENT MULTIPLIERS

- Frequency Multipliers

Capacitance (µF)	Frequency (Hz)					
	50	120	300	1k	10k	100k
0.1 to 4.7	0.65	1.00	1.35	1.75	2.30	2.50
10 to 47	0.75	1.00	1.25	1.50	1.75	1.80
100 to 1,000	0.80	1.00	1.15	1.30	1.40	1.50
2,200 to	0.85	1.00	1.03	1.05	1.08	1.08

◆STANDARD RATINGS

μF	V _{dc}		6.3		10		16		25		35		50		63		100		
	10	25	Case size φD×L (mm)	Rated ripple current (mA _{rms}) at 85°C, 120Hz															
0.1													5×11	1.3			5×11	2.6	
0.22													5×11	2.9			5×11	5.8	
0.33													5×11	4.4			5×11	8.8	
0.47													5×11	7			5×11	12	
1.0													5×11	13			5×11	22	
2.2													5×11	29			5×11	33	
3.3													5×11	35			5×11	40	
4.7													5×11	42	5×11	45	5×11	48	
10													5×11	65	5×11	70	6.3×11	80	
22													5×11	95	6.3×11	115	8×11.5	135	
33												5×11	105	6.3×11	125	6.3×11	140	10×12.5	195
47							5×11	110	5×11	115	6.3×11	145	6.3×11	150	8×11.5	190	10×16	255	
100	5×11	130	5×11	145	6.3×11	180	6.3×11	190	8×11.5	240	8×11.5	240	8×11.5	255	10×12.5	320	12.5×20	450	
220	6.3×11	230	6.3×11	250	8×11.5	300	8×11.5	320	10×12.5	420	10×16	490	10×16	490	10×20	565	16×25	810	
330	6.3×11	280	8×11.5	350	8×11.5	370	10×12.5	470	10×16	570	10×20	650	12.5×20	765	16×25	990			
470	8×11.5	380	8×11.5	415	10×12.5	520	10×16	620	10×20	740	12.5×20	860	12.5×25	990	16×31.5	1,250			
1,000	10×12.5	650	10×16	790	10×20	910	12.5×20	1,090	12.5×25	1,300	16×25	1,530	16×31.5	1,700					
2,200	12.5×20	1,150	12.5×20	1,240	12.5×25	1,420	16×25	1,660	16×31.5	1,890	18×35.5	2,160							
3,300	12.5×20	1,380	12.5×25	1,590	16×25	1,840	16×31.5	2,070	18×35.5	2,340									
4,700	16×25	1,880	16×25	1,980	16×31.5	2,260	18×35.5	2,520	18×40	2,690									
6,800	16×25	2,120	16×31.5	2,390	18×35.5	2,690	18×40	2,830											
10,000	16×31.5	2,500	18×35.5	2,840	18×40	2,920													
15,000	18×35.5	2,990																	

Non solvent-proof														
μF	V _{dc}		160		200		250		350		400		450	
	10	25	Case size φD×L (mm)	Rated ripple current (mA _{rms}) at 85°C, 120Hz										
0.47	6.3×11	12	6.3×11	12	6.3×11	12	8×11.5	15						
1.0	6.3×11	17	6.3×11	17	6.3×11	17	8×11.5	22	8×11.5	22	10×12.5	25		
2.2	6.3×11	26	6.3×11	26	8×11.5	30	10×12.5	39	10×12.5	39	10×16	42		
3.3	8×11.5	36	8×11.5	36	10×12.5	43	10×16	53	10×16	53	10×20	56		
4.7	8×11.5	44	10×12.5	51	10×12.5	51	10×16	63	10×20	69	12.5×20	75		
10	10×16	83	10×16	83	10×20	90	12.5×20	115	12.5×20	115	12.5×25	120		
22	10×20	130	10×20	130	12.5×25	160	12.5×25	180	16×25	200	16×31.5	210		
33	12.5×20	180	12.5×25	190	12.5×25	190	16×25	245	16×31.5	265	18×35.5	275		
47	12.5×25	230	12.5×25	230	16×25	260	16×31.5	315	16×35.5	325				
100	16×25	380	16×31.5	400	18×35.5	440	18×40	500						
220	18×35.5	640	18×40	660										

◆MAXIMUM ESR

(Ω) at 20°C, 120Hz

μF	V _{dc}		6.3		10		16		25		35		50		63		100		160 to 250		350 to 450	
	10	25																				
0.1													1,660				1,330					
0.22													754				603					
0.33													503				402					
0.47													353				282			706		847
1.0													166				133			332		398
2.2													75.4				60.3			151		181
3.3													50.3				40.3			101		121
4.7													35.3		31.8		28.2			70.6		84.7
10													16.6		14.9		13.3			33.2		39.8
22													7.54		6.79		6.03			15.1		18.1
33													6.03		5.03		4.52			10.1		12.1
47													4.23		3.53		3.18			7.06		8.47
100													3.70		3.15		2.65			3.32		3.98
220													1.66		1.43		1.21			1.51		
330													1.11		0.955		0.804					
470													0.776		0.671		0.565					
1,000													0.370		0.315		0.265					
2,200													0.181		0.158		0.136					
3,300													0.131		0.116		0.101					
4,700													0.0988		0.0882		0.0776					
6,800													0.0781		0.0707		0.0634					
10,000													0.0630		0.0581		0.0531					
15,000													0.0531									

KME Series

- Endurance with ripple current : 105°C 1000 hours
- Solvent-proof type, except 350 to 400V_{dc}, see page 16

KMG ← **KME**
downsized



◆SPECIFICATIONS

Items	Characteristics											
Category	-55 to +105°C(6.3 to 100V _{dc}) -40 to +105°C(160 to 400V _{dc})											
Temperature Range												
Rated Voltage Range	6.3 to 400V _{dc}											
Capacitance Tolerance	±20% (M) (at 20°C, 120Hz)											
Leakage Current	6.3 to 100V _{dc}										160 to 400V _{dc}	
	I=0.03CV or 4μA, whichever is greater. (at 20°C after 1 minute)										CV \ Time	
	I=0.01CV or 3μA, whichever is greater. (at 20°C after 2 minutes)										After 1minute	
											After 5minutes	
										CV≤1000	I=0.1CV+40	I=0.03CV+15
										CV>1000	I=0.04CV+100	I=0.02CV+25
											(at 20°C)	
Where, I : Max. leakage current (μA), C : Nominal capacitance (μF), V : Rated voltage (V)												
Dissipation Factor (tanδ)	Rated voltage (V _{dc})	6.3V	10V	16V	25V	35V	50V	63V	100V	160 to 250V	350 to 400V	
	tanδ (Max.)	0.22	0.19	0.16	0.14	0.12	0.10	0.09	0.08	0.20	0.24	
	When nominal capacitance exceeds 1000μF, add 0.02 to the value above for each 1000μF increase. (at 20°C, 120Hz)											
Low Temperature Characteristics (Max. Impedance Ratio)	Rated voltage (V _{dc})	6.3V	10V	16V	25V	35V	50V	63V	100V	160 to 250V	350 to 400V	
	Z(-25°C)/Z(+20°C)	4	3	2	2	2	2	2	2	3	6	
	Z(-40°C)/Z(+20°C)	8	6	4	3	3	3	3	3	4	6	
											(at 120Hz)	
Endurance	The following specifications shall be satisfied when the capacitors are restored to 20°C after subjected to DC voltage with the rated ripple current is applied for 1000 hours at 105°C.											
	Capacitance change	≤±20% of the initial value										
	DF (tanδ)	≤200% of the initial specified value										
	Leakage current	≤The initial specified value										
Shelf Life	The following specifications shall be satisfied when the capacitors are restored to 20°C after exposing them for 1000 hours at 105°C without voltage applied.											
	Rated voltage	6.3 to 100V _{dc}					160 to 400V _{dc}					
	Capacitance change	≤±20% of the initial value					≤±20% of the initial value					
	DF (tanδ)	≤200% of the initial specified value					≤200% of the initial specified value					
	Leakage current	≤The initial specified value					≤500% of the initial specified value					

◆DIMENSIONS (Radial Lead Type=VB) [mm]

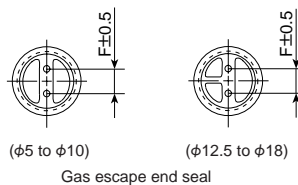
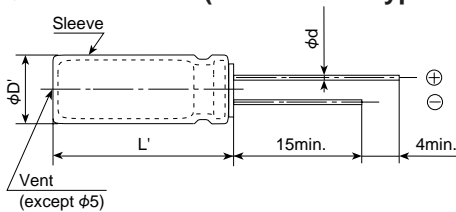

φD	5	6.3	8	10	12.5	16	18
φd	0.5	0.5	0.6	0.6	0.6	0.8	0.8
F	2.0	2.5	3.5	5.0	5.0	7.5	7.5
φD'	φD+0.5max.						
L'	L+1.5max						

◆PART NUMBERING SYSTEM

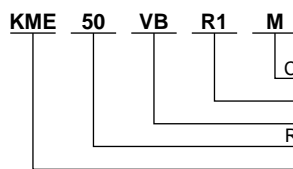

Capacitance	Code
0.1μF	R1
0.47μF	R47
1.0μF	1
4.7μF	4R7
10μF	10
100μF	100

◆RATED RIPPLE CURRENT MULTIPLIERS

- Frequency Multipliers

Capacitance (μF)	Frequency (Hz)					
	50	120	300	1k	10k	100k
0.1 to 4.7	0.65	1.00	1.35	1.75	2.30	2.50
10 to 47	0.75	1.00	1.25	1.50	1.75	1.80
100 to 1,000	0.80	1.00	1.15	1.30	1.40	1.50
2,200 to	0.85	1.00	1.03	1.05	1.08	1.08

◆STANDARD RATINGS

μF \ V_{dc}	6.3		10		16		25		35		50		63		100							
0.1											5×11	1.3			5×11	2.6						
0.22											5×11	2.9			5×11	5.8						
0.33											5×11	4.4			5×11	7.8						
0.47											5×11	7			5×11	10						
1.0	<div style="display: flex; justify-content: space-around; align-items: center;"> <div style="text-align: center;"> <p>Case size $\phi\text{D}\times\text{L}$ (mm)</p> <p>Rated ripple current (mA rms) at 105°C, 120Hz</p> </div> </div>																5×11	13			5×11	15
2.2																	5×11	20			5×11	23
3.3																	5×11	25			5×11	29
4.7																	5×11	30	5×11	32	5×11	34
10																	5×11	46	5×11	50	6.3×11	56
22										5×11	68	6.3×11	82	8×11.5	96							
33									5×11	75	6.3×11	90	6.3×11	100	10×12.5	140						
47					5×11	77	5×11	82	6.3×11	100	6.3×11	110	8×11.5	135	10×16	180						
100	5×11	95	5×11	105	6.3×11	125	6.3×11	135	8×11.5	170	8×11.5	180	10×12.5	225	12.5×20	320						
220	6.3×11	160	6.3×11	175	8×11.5	215	8×11.5	230	10×12.5	300	10×16	345	10×20	400	16×25	570						
330	6.3×11	195	8×11.5	245	8×11.5	260	10×12.5	335	10×16	400	10×20	460	12.5×20	540	16×25	700						
470	8×11.5	270	8×11.5	290	10×12.5	370	10×16	440	10×20	520	12.5×20	610	12.5×25	700	16×31.5	880						
1,000	10×12.5	460	10×16	550	10×20	640	12.5×20	770	12.5×25	920	16×25	1,080	16×31.5	1,210								
2,200	12.5×20	810	12.5×20	860	12.5×25	1,000	16×25	1,170	16×31.5	1,340	18×35.5	1,530										
3,300	12.5×20	960	12.5×25	1,100	16×25	1,300	16×31.5	1,460	18×35.5	1,650												
4,700	16×25	1,330	16×25	1,400	16×31.5	1,600	18×35.5	1,780	18×40	1,900												
6,800	16×25	1,500	16×31.5	1,690	18×35.5	1,900	18×40	1,950														
10,000	16×31.5	1,765	18×35.5	1,950	18×40	2,060																
15,000	18×35.5	2,075																				

Non solvent-proof

μF \ V_{dc}	160		200		250		350		400	
0.47	6.3×11	9	6.3×11	9	6.3×11	9	8×11.5	10		
1.0	6.3×11	12	6.3×11	12	6.3×11	12	10×12.5	18	10×12.5	18
2.2	6.3×11	19	6.3×11	19	8×11.5	21	10×16	30	10×16	30
3.3	8×11.5	26	8×11.5	26	10×12.5	30	10×16	37	10×20	40
4.7	8×11.5	31	10×12.5	36	10×12.5	36	10×20	48	10×25	52
10	10×16	59	10×16	59	10×20	64	12.5×20	79	12.5×25	79
22	10×20	95	10×20	95	12.5×25	110	16×20	130	16×25	145
33	12.5×20	125	12.5×25	140	12.5×25	140	16×25	175	16×31.5	185
47	12.5×25	165	12.5×25	165	16×25	180	16×35.5	230	18×31.5	230
100	16×25	270	16×31.5	285	18×35.5	310	18×40	330		
220	18×35.5	450	18×40	470						

◆MAXIMUM ESR

(Ω) at 20°C, 120Hz

μF \ V_{dc}	6.3	10	16	25	35	50	63	100	160 to 250	350 to 400
0.1						1,660		1,330		
0.22						754		603		
0.33						503		402		
0.47						353		282	706	847
1.0						166		133	332	398
2.2						75.4		60.3	151	181
3.3						50.3		40.3	101	121
4.7						35.3	31.8	28.2	70.6	84.7
10						16.6	14.9	13.3	33.2	39.8
22						7.54	6.79	6.03	15.1	18.1
33						6.03	5.03	4.52	10.1	12.1
47			5.65	4.94	4.23	3.53	3.18	2.82	7.06	8.47
100	3.70	3.15	2.65	2.32	1.99	1.66	1.49	1.33	3.32	3.98
220	1.66	1.43	1.21	1.06	0.905	0.754	0.679	0.603	1.51	
330	1.11	0.955	0.804	0.704	0.603	0.503	0.452	0.402		
470	0.776	0.671	0.565	0.494	0.423	0.353	0.318	0.282		
1,000	0.370	0.315	0.265	0.232	0.199	0.166	0.149			
2,200	0.181	0.158	0.136	0.121	0.106	0.0905				
3,300	0.131	0.116	0.101	0.0905	0.0804					
4,700	0.0988	0.0882	0.0776	0.0706	0.0635					
6,800	0.0781	0.0707	0.0634	0.0585						
10,000	0.0630	0.0581	0.0531							
15,000	0.0531									

KMY Series

- Endurance : 105°C 4000 to 7000 hours
- Long life and impedance specified version of KME series
- Non solvent-proof

KMY ← KME
longer life



◆SPECIFICATIONS

Items	Characteristics					
Category Temperature Range	-40 to +105°C					
Rated Voltage Range	10 to 50V _{dc}					
Capacitance Tolerance	±20% (M) (at 20°C, 120Hz)					
Leakage Current	I=0.01CV or 3µA, whichever is greater. Where, I : Max. leakage current (µA), C : Nominal capacitance (µF), V : Rated voltage (V) (at 20°C after 2 minutes)					
Dissipation Factor (tanδ)	Rated voltage (V _{dc})	10V	16V	25V	35V	50V
	tanδ (Max.)	0.19	0.16	0.14	0.12	0.10
	When nominal capacitance exceeds 1000µF, add 0.02 to the value above for each 1000µF increase. (at 20°C, 120Hz)					
Low Temperature Characteristics (Max. Impedance Ratio)	Rated voltage (V _{dc})	10V	16V	25V	35V	50V
	Z(-25°C)/Z(+20°C)	3	2	2	2	2
	Z(-40°C)/Z(+20°C)	6	4	3	3	3
Endurance	The following specifications shall be satisfied when the capacitors are restored to 20°C after subjected to DC voltage with the rated ripple current is applied for the specified period of time at 105°C.					
	Time	φ5 & 6.3 : 4000hours φ8 & 10 : 5000hours φ12.5 and larger : 7000hours				
	Capacitance change	≤±25% of the initial value				
	DF (tanδ)	≤200% of the initial specified value				
	Leakage current	≤The initial specified value				
Shelf Life	The following specifications shall be satisfied when the capacitors are restored to 20°C after exposing them for 1000 hours at 105°C without voltage applied.					
	Capacitance change	≤±25% of the initial value				
	DF (tanδ)	≤200% of the initial specified value				
	Leakage current	≤The initial specified value				

◆DIMENSIONS (Radial Lead Type=VB) [mm]

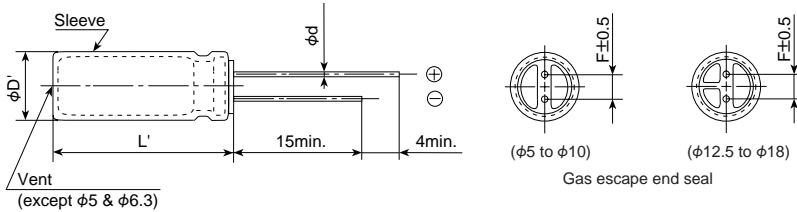

φD	5	6.3	8	10	12.5	16	18
φd	0.5	0.5	0.6	0.6	0.6	0.8	0.8
F	2.0	2.5	3.5	5.0	5.0	7.5	7.5
φD'	φD+0.5max.						
L'	L+1.5max.						

◆PART NUMBERING SYSTEM

KMY 50 VB 1000 M

Cap tolerance (±20%)
Nominal cap code
Radial lead type
Rated voltage in volts
Series name

Capacitance	Code
0.47µF	R47
1.0µF	1
4.7µF	4R7
10µF	10
100µF	100

◆STANDARD RATINGS

μF	Items	V _{dc}	10			16				
			Case size φD×L (mm)	Impedance (Ω _{max} /100kHz)		Rated ripple current (mA _{RMS} /105°C, 100kHz)	Case size φD×L (mm)	Impedance (Ω _{max} /100kHz)		Rated ripple current (mA _{RMS} /105°C, 100kHz)
				20°C	-10°C			20°C	-10°C	
47						5×11.5	0.9	3.6	150	
100			5×11.5	0.9	3.6	150	6.3×11.5	0.4	1.6	245
220			6.3×11.5	0.4	1.6	245	8×12	0.25	1.0	395
330			8×12	0.25	1.0	395	8×12	0.25	1.0	395
470			8×12	0.25	1.0	395	10×12.5	0.16	0.65	580
1,000			10×16	0.12	0.46	765	10×20	0.078	0.30	1,010
2,200			12.5×20	0.062	0.21	1,300	12.5×25	0.048	0.16	1,650
3,300			12.5×25	0.048	0.16	1,650	16×25	0.034	0.096	1,850
4,700			16×25	0.034	0.096	1,850	16×31.5	0.029	0.087	2,000
6,800			16×31.5	0.029	0.087	2,000	18×35.5	0.025	0.058	2,200
10,000			18×35.5	0.025	0.058	2,200				

μF	Items	V _{dc}	25			35				
			Case size φD×L (mm)	Impedance (Ω _{max} /100kHz)		Rated ripple current (mA _{RMS} /105°C, 100kHz)	Case size φD×L (mm)	Impedance (Ω _{max} /100kHz)		Rated ripple current (mA _{RMS} /105°C, 100kHz)
				20°C	-10°C			20°C	-10°C	
33			5×11.5	0.9	3.6	150	5×11.5	0.9	3.6	150
47			5×11.5	0.9	3.6	150	6.3×11.5	0.4	1.6	245
100			6.3×11.5	0.4	1.6	245	8×12	0.25	1.0	395
220			8×12	0.25	1.0	395	10×12.5	0.16	0.65	580
330			10×12.5	0.16	0.65	580	10×16	0.12	0.46	765
470			10×16	0.12	0.46	765	10×20	0.078	0.30	1,010
1,000			12.5×20	0.062	0.21	1,300	12.5×25	0.048	0.16	1,650
2,200			16×25	0.034	0.096	1,850	16×31.5	0.029	0.087	2,000
3,300			16×31.5	0.029	0.087	2,000	18×35.5	0.025	0.058	2,200
4,700			18×35.5	0.025	0.058	2,200				

μF	Items	V _{dc}	50			
			Case size φD×L (mm)	Impedance (Ω _{max} /100kHz)		Rated ripple current (mA _{RMS} /105°C, 100kHz)
				20°C	-10°C	
0.47			5×11.5	5.5	22.0	17
1.0			5×11.5	4.0	16.0	30
2.2			5×11.5	2.5	10.0	43
3.3			5×11.5	2.2	8.8	53
4.7			5×11.5	1.9	7.6	88
10			5×11.5	1.5	6.0	100
22			5×11.5	0.9	3.6	150
33			6.3×11.5	0.4	1.6	245
47			6.3×11.5	0.4	1.6	245
100			8×12	0.25	1.0	395
220			10×16	0.12	0.46	765
330			10×20	0.088	0.34	1,010
470			12.5×20	0.062	0.21	1,300
1,000			16×25	0.034	0.096	1,850
2,200			18×35.5	0.025	0.058	2,200

◆RATED RIPPLE CURRENT MULTIPLIERS

●Frequency Multipliers

Capacitance (μF)	Frequency (Hz)			
	120	1k	10k	100k
0.47 to 4.7	0.40	0.70	0.90	1.00
10 to 330	0.55	0.80	0.95	1.00
470 to 1,000	0.70	0.85	0.95	1.00
2,200 to 10,000	0.80	0.95	1.00	1.00

SME-BP Series

- Standard Bi-polarized type
- Endurance : 85°C 2000 hours
- Solvent-proof type, see page 16

SME-BP

↑
bi-polarized
SME



◆ SPECIFICATIONS

Items	Characteristics										
Category	-40 to +85°C										
Temperature Range	-40 to +85°C										
Rated Voltage Range	6.3 to 100V _{dc}										
Capacitance Tolerance	±20% (M) (at 20°C, 120Hz)										
Leakage Current	I=0.06CV or 10μA, whichever is greater. (at 20°C after 2 minutes) I=0.03CV or 3μA, whichever is greater. (at 20°C after 5 minutes) Where, I : Max. leakage current (μA), C : Nominal capacitance (μF), V : Rated voltage (V)										
Dissipation Factor (tanδ)	Rated voltage (V _{dc})	6.3V	10V	16V	25V	35V	50V	63V	80V	100V	
	tanδ (Max.)	0.24	0.24	0.20	0.20	0.16	0.14	0.12	0.12	0.10	
	When nominal capacitance exceeds 1000μF, add 0.02 to the value above for each 1000μF increase. (at 20°C, 120Hz)										
Low Temperature Characteristics (Max. Impedance Ratio)	Rated voltage (V _{dc})	6.3V	10V	16V	25V	35V	50V	63V	80V	100V	
	Z(-25°C)/Z(+20°C)	4	3	2	2	2	2	2	2	2	
	Z(-40°C)/Z(+20°C)	10	8	6	4	3	3	3	3	3	
	(at 120Hz)										
Endurance	The following specifications shall be satisfied when the capacitors are restored to 20°C after the rated voltage is applied for 2000 hours at 85°C, however the polarization shall be reversed every 250 hours.										
	Rated voltage	6.3 to 16V _{dc}					25 to 100V _{dc}				
	Capacitance change	≤±25% of the initial value					≤±20% of the initial value				
	DF (tanδ)	≤150% of the initial specified value									
	Leakage current	≤The initial specified value									
Shelf Life	The following specifications shall be satisfied when the capacitors are restored to 20°C after exposing them for 1000 hours at 85°C without voltage applied.										
	Rated voltage	6.3 to 16V _{dc}					25 to 100V _{dc}				
	Capacitance change	≤±25% of the initial value					≤±20% of the initial value				
	DF (tanδ)	≤150% of the initial specified value									
	Leakage current	≤The initial specified value									

◆ DIMENSIONS (Radial Lead Type=VB) [mm]

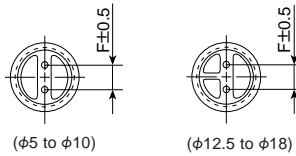
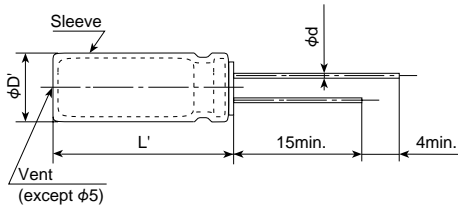

Gas escape end seal

φD	5	6.3	8	10	12.5	16	18
φd	0.5	0.5	0.6	0.6	0.6	0.8	0.8
F	2.0	2.5	3.5	5.0	5.0	7.5	7.5
φD'	φD+0.5max.						
L'	L+1.5max.						

◆ PART NUMBERING SYSTEM

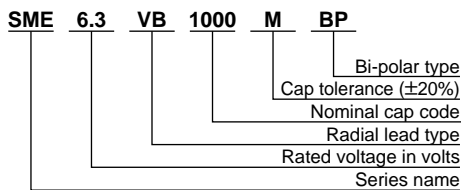

Capacitance	Code
0.47μF	R47
1.0μF	1
4.7μF	4R7
10μF	10
100μF	100

◆ STANDARD RATINGS

μF	6.3		10		16		25		35		50		63		80		100		
0.47											5X11	11					5X11	14	
1.0											5X11	17					5X11	21	
2.2											5X11	25			5X11	29	6.3X11	34	
3.3											5X11	27	5X11	28	6.3X11	39	6.3X11	39	
4.7											5X11	34	6.3X11	34	6.3X11	47	6.3X11	47	
10										5X11	43	6.3X11	52	6.3X11	57	8X11.5	65	8X11.5	71
22					5X11	57	6.3X11	65	6.3X11	73	8X11.5	89	8X11.5	95	10X16	125	10X16	135	
33					5X11	70	6.3X11	80	8X11.5	100	8X11.5	105	10X12.5	135	10X16	150	12.5X20	220	
47					5X11	76	6.3X11	95	6.3X11	95	8X11.5	120	10X12.5	150	10X16	180	10X20	240	
100	6.3X11	125	6.3X11	125	8X11.5	160	8X11.5	160	10X16	230	10X20	265	12.5X20	320	12.5X25	350	16X25	425	
220	8X11.5	215	8X11.5	215	10X12.5	275	10X16	305	12.5X20	410	12.5X25	480	16X25	575	16X31.5	615	18X35.5	720	
330	8X11.5	265	10X16	345	10X16	375	12.5X20	450	12.5X20	505	16X25	650	16X31.5	655	18X35.5	755			
470	10X12.5	370	10X16	410	10X20	485	12.5X20	540	12.5X25	655	16X31.5	835	18X35.5	965					
1,000	10X20	650	12.5X20	720	12.5X25	855	16X25	950	16X31.5	1,140									
2,200	12.5X25	1,160	16X25	1,280	16X31.5	1,510	18X35.5	1,620											
3,300	16X25	1,570	16X31.5	1,690	18X35.5	1,980													
4,700	16X31.5	2,020	18X35.5	2,160															
6,800	18X35.5	2,600																	

KME-BP Series

- Standard Bi-polarized type
- Endurance : 105°C 1000 hours
- Solvent-proof type, see page 16

KME-BP

↑ bi-polarized
KME



◆ SPECIFICATIONS

Items	Characteristics										
Category	-55 to +105°C										
Temperature Range	-55 to +105°C										
Rated Voltage Range	6.3 to 100V _{dc}										
Capacitance Tolerance	±20% (M) (at 20°C, 120Hz)										
Leakage Current	I=0.06CV or 10μA, whichever is greater. (at 20°C after 2 minutes) I=0.03CV or 3μA, whichever is greater. (at 20°C after 5 minutes) Where, I : Max. leakage current (μA), C : Nominal capacitance (μF), V : Rated voltage (V)										
Dissipation Factor (tanδ)	Rated voltage (V _{dc})	6.3V	10V	16V	25V	35V	50V	63V	80V	100V	
	tanδ (Max.)	0.24	0.24	0.20	0.20	0.16	0.14	0.12	0.12	0.10	
When nominal capacitance exceeds 1000μF, add 0.02 to the value above for each 1000μF increase. (at 20°C, 120Hz)											
Low Temperature Characteristics (Max. Impedance Ratio)	Rated voltage (V _{dc})	6.3V	10V	16V	25V	35V	50V	63V	80V	100V	
	Z(-25°C)/Z(+20°C)	4	3	2	2	2	2	2	2	2	
	Z(-40°C)/Z(+20°C)	10	8	6	4	3	3	3	3	3	
(at 120Hz)											
Endurance	The following specifications shall be satisfied when the capacitors are restored to 20°C after the rated voltage is applied for 1000 hours at 105°C, however the polarization shall be reversed every 250 hours.										
	Rated voltage	6.3 to 16V _{dc}					25 to 100V _{dc}				
	Capacitance change	≤±25% of the initial value					≤±20% of the initial value				
	DF (tanδ)	≤150% of the initial specified value									
	Leakage current	≤The initial specified value									
Shelf Life	The following specifications shall be satisfied when the capacitors are restored to 20°C after exposing them for 500 hours at 105°C without voltage applied.										
	Rated voltage	6.3 to 16V _{dc}					25 to 100V _{dc}				
	Capacitance change	≤±25% of the initial value					≤±20% of the initial value				
	DF (tanδ)	≤150% of the initial specified value									
	Leakage current	≤The initial specified value									

◆ DIMENSIONS (Radial Lead Type=VB) [mm]

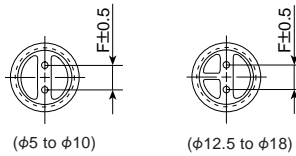
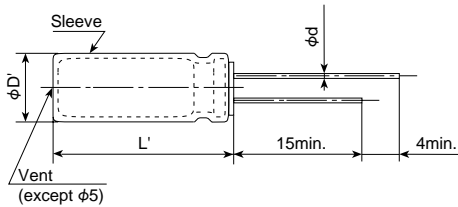

Gas escape end seal

φD	5	6.3	8	10	12.5	16	18
φd	0.5	0.5	0.6	0.6	0.6	0.8	0.8
F	2.0	2.5	3.5	5.0	5.0	7.5	7.5
φD'	φD+0.5max.						
L'	L+1.5max.						

◆ PART NUMBERING SYSTEM

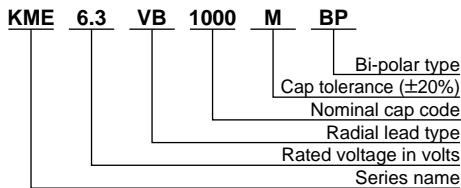

Capacitance	Code
0.47μF	R47
1.0μF	1
4.7μF	4R7
10μF	10
100μF	100

◆ STANDARD RATINGS

μF \ V _{dc}	6.3	10	16	25	35	50	63	80	100
0.47						5X11	7		5X11
1.0						5X11	10		5X11
2.2						5X11	15	5X11	16
3.3						5X11	18	5X11	20
4.7						5X11	22	6.3X11	23
10						5X11	22	6.3X11	25
22						5X11	30	6.3X11	27
33						5X11	37	6.3X11	27
47						5X11	40	6.3X11	27
100	6.3X11	90	5X11	40	6.3X11	51	6.3X11	68	8X11.5
220	8X11.5	150	8X11.5	40	6.3X11	51	6.3X11	68	8X11.5
330	8X11.5	185	10X12.5	46	6.3X11	51	6.3X11	68	8X11.5
470	10X12.5	260	10X16	46	6.3X11	51	6.3X11	68	8X11.5
1,000	10X20	460	10X16	49	6.3X11	56	8X11.5	72	8X11.5
2,200	12.5X25	820	10X16	67	6.3X11	67	8X11.5	86	10X12.5
3,300	16X25	1,110	10X16	67	6.3X11	67	8X11.5	86	10X12.5
4,700	16X31.5	1,430	10X20	67	6.3X11	67	8X11.5	86	10X12.5
6,800	18X35.5	1,830	12.5X20	110	8X11.5	110	10X16	160	10X20
			12.5X25	110	8X11.5	110	10X16	160	10X20
			16X25	150	10X12.5	195	12.5X20	290	12.5X25
			16X31.5	150	10X12.5	195	12.5X20	290	12.5X25
			18X35.5	240	10X16	265	12.5X20	320	12.5X20
			18X35.5	240	10X16	265	12.5X20	320	12.5X20
			18X35.5	290	10X20	345	12.5X20	380	12.5X20
			18X35.5	290	10X20	345	12.5X20	380	12.5X20
			18X35.5	460	12.5X25	605	16X25	670	16X31.5
			18X35.5	460	12.5X25	605	16X25	670	16X31.5
			18X35.5	820	16X25	910	16X31.5	1,070	18X35.5
			18X35.5	820	16X25	910	16X31.5	1,070	18X35.5
			18X35.5	1,110	16X31.5	1,200	18X35.5	1,400	
			18X35.5	1,110	16X31.5	1,200	18X35.5	1,400	
			18X35.5	1,430	18X35.5	1,520			
			18X35.5	1,430	18X35.5	1,520			

LXZ Series

- Newly innovative electrolyte and internal architecture are employed
- Lowest impedance at high frequency range
- Endurance with ripple current: 105°C 2000 to 8000 hours
- Solvent-proof type

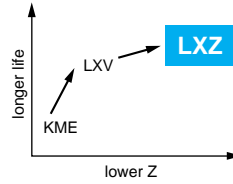

SPECIFICATIONS

Items	Characteristics																
Category Temperature Range	-55 to +105°C																
Rated Voltage Range	6.3 to 63V _{dc}																
Capacitance Tolerance	±20% (M) (at 20°C, 120Hz)																
Leakage Current	I = 0.01CV or 3µA, whichever is greater. Where, I : Max. leakage current (µA), C : Nominal capacitance (µF), V : Rated voltage (V) (at 20°C after 2 minutes)																
Dissipation Factor (tanδ)	<table border="1"> <tr> <td>Rated voltage (V_{dc})</td> <td>6.3V</td> <td>10V</td> <td>16V</td> <td>25V</td> <td>35V</td> <td>50V</td> <td>63V</td> </tr> <tr> <td>tanδ (Max.)</td> <td>0.22</td> <td>0.19</td> <td>0.16</td> <td>0.14</td> <td>0.12</td> <td>0.10</td> <td>0.08</td> </tr> </table>	Rated voltage (V _{dc})	6.3V	10V	16V	25V	35V	50V	63V	tanδ (Max.)	0.22	0.19	0.16	0.14	0.12	0.10	0.08
	Rated voltage (V _{dc})	6.3V	10V	16V	25V	35V	50V	63V									
tanδ (Max.)	0.22	0.19	0.16	0.14	0.12	0.10	0.08										
	When nominal capacitance exceeds 1000µF, add 0.02 to the value above for each 1000µF increase. (at 20°C, 120Hz)																
Endurance	The following specifications shall be satisfied when the capacitors are restored to 20°C after subjected to DC voltage with the rated ripple current is applied for the specified period of time at 105°C.																
	<table border="1"> <tr> <td>Time</td> <td>φ5 & 6.3 : 2000hours</td> <td>φ8 : 3000hours</td> <td>φ10 : 5000hours</td> <td>φ12.5 : 7000hours</td> <td>φ16 & 18 : 8000hours</td> </tr> </table>	Time	φ5 & 6.3 : 2000hours	φ8 : 3000hours	φ10 : 5000hours	φ12.5 : 7000hours	φ16 & 18 : 8000hours										
	Time	φ5 & 6.3 : 2000hours	φ8 : 3000hours	φ10 : 5000hours	φ12.5 : 7000hours	φ16 & 18 : 8000hours											
	Capacitance change	≤±20% of the initial value															
DF (tanδ)	≤200% of the initial specified value																
Shelf Life	The following specifications shall be satisfied when the capacitors are restored to 20°C after exposing them for 1000 hours at 105°C without voltage applied.																
	Capacitance change	≤±20% of the initial value															
	DF (tanδ)	≤200% of the initial specified value															
	Leakage current	≤The initial specified value															

DIMENSIONS (Radial Lead Type=VB) [mm]

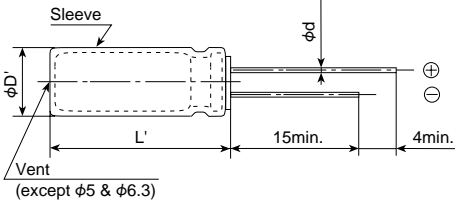

φD	5	6.3	8	10	12.5	16	18
φd	0.5	0.5	0.6	0.6	0.6	0.8	0.8
F	2.0	2.5	3.5	5.0	5.0	7.5	7.5
φD'	φD+0.5max.						
L'	L+1.5max.						

PART NUMBERING SYSTEM

LXZ 16 VB 2200 M K25

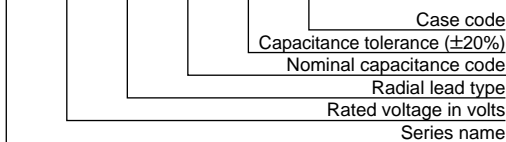

Capacitance	Code
4.7µF	4R7
10µF	10
100µF	100
2200µF	2200

◆STANDARD RATINGS

φD×L	V _{dc} Case code	6.3			10			16			25						
		Capacitance (μF)	Impedance (Ω _{max} /100kHz)		Rated ripple current (mArms/105°C/100kHz)	Capacitance (μF)	Impedance (Ω _{max} /100kHz)		Rated ripple current (mArms/105°C/100kHz)	Capacitance (μF)	Impedance (Ω _{max} /100kHz)		Rated ripple current (mArms/105°C/100kHz)				
			20°C	-10°C			20°C	-10°C			20°C	-10°C		20°C	-10°C		
5×11.5	E11	150	0.50	1.0	175	100	0.50	1.0	175	47	0.50	1.0	175	47	0.50	1.0	175
6.3×11.5	F11	330	0.25	0.50	290	220	0.25	0.50	290	100	0.25	0.50	290	100	0.25	0.50	290
6.3×15	F15	470	0.18	0.36	400	330	0.18	0.36	400	220	0.18	0.36	400	150	0.18	0.36	400
8×12	H12	680	0.12	0.24	555	470	0.12	0.24	555	330	0.12	0.24	555	220	0.12	0.24	555
8×15	H15	1,000	0.090	0.18	730	680	0.090	0.18	730	470	0.090	0.18	730	330	0.090	0.18	730
8×20	H20	1,200	0.080	0.16	810	1,000	0.080	0.16	810	560	0.080	0.16	810	390	0.080	0.16	810
10×12.5	J12	820	0.090	0.18	760	680	0.090	0.18	760	470	0.090	0.18	760	330	0.090	0.18	760
10×16	J16	1,200	0.068	0.136	1,050	1,000	0.068	0.136	1,050	680	0.068	0.136	1,050	470	0.068	0.136	1,050
10×20	J20	1,500	0.052	0.104	1,220	1,200	0.052	0.104	1,220	1,000	0.052	0.104	1,220	680	0.052	0.104	1,220
10×25	J25	2,200	0.045	0.090	1,440	1,500	0.045	0.090	1,440	1,200	0.045	0.090	1,440	820	0.045	0.090	1,440
10×30	J30	2,700	0.037	0.074	1,690	1,800	0.037	0.074	1,690	1,500	0.037	0.074	1,690	1,000	0.037	0.074	1,690
12.5×20	K20	3,300	0.038	0.076	1,660	2,200	0.038	0.076	1,660	1,500	0.038	0.076	1,660	1,000	0.038	0.076	1,660
12.5×25	K25	3,900	0.030	0.060	1,950	3,300	0.030	0.060	1,950	2,200	0.030	0.060	1,950	1,500	0.030	0.060	1,950
12.5×30	K30	4,700	0.025	0.050	2,310	3,900	0.025	0.050	2,310	2,700	0.025	0.050	2,310	1,800	0.025	0.050	2,310
12.5×35	K35	5,600	0.022	0.044	2,510	4,700	0.022	0.044	2,510	3,300	0.022	0.044	2,510	2,200	0.022	0.044	2,510
12.5×40	K40	6,800	0.017	0.034	2,870	5,600	0.017	0.034	2,870	3,900	0.017	0.034	2,870	2,700	0.017	0.034	2,870
16×20	L20	5,600	0.029	0.058	2,210	3,900	0.029	0.058	2,210	2,700	0.029	0.058	2,210	1,800	0.029	0.058	2,210
16×25	L25	6,800	0.022	0.044	2,560	5,600	0.022	0.044	2,560	3,900	0.022	0.044	2,560	2,700	0.022	0.044	2,560
16×30	L30	8,200	0.019	0.038	3,010	6,800	0.019	0.038	3,010	4,700	0.019	0.038	3,010	3,300	0.019	0.038	3,010
16×35	L35	10,000	0.017	0.034	3,150	8,200	0.017	0.034	3,150	5,600	0.017	0.034	3,150	3,900	0.017	0.034	3,150
16×40	L40	12,000	0.015	0.030	3,710	10,000	0.015	0.030	3,710	6,800	0.015	0.030	3,710	4,700	0.015	0.030	3,710
18×20	M20	6,800	0.028	0.056	2,490	5,600	0.028	0.056	2,490	3,900	0.028	0.056	2,490	2,200	0.028	0.056	2,490
18×25	M25	10,000	0.020	0.040	2,740	6,800	0.020	0.040	2,740	4,700	0.020	0.040	2,740	3,300	0.020	0.040	2,740
18×30	M30	12,000	0.018	0.036	3,330	8,200	0.018	0.036	3,330	5,600	0.018	0.036	3,330	3,900	0.018	0.036	3,330
18×35	M35	15,000	0.016	0.032	3,680	10,000	0.016	0.032	3,680	8,200	0.016	0.032	3,680	4,700	0.016	0.032	3,680
18×40	M40	18,000	0.015	0.030	3,800	12,000	0.015	0.030	3,800	10,000	0.015	0.030	3,800	5,600	0.015	0.030	3,800

φD×L	V _{dc} Case code	35			50			63					
		Capacitance (μF)	Impedance (Ω _{max} /100kHz)		Rated ripple current (mArms/105°C/100kHz)	Capacitance (μF)	Impedance (Ω _{max} /100kHz)		Rated ripple current (mArms/105°C/100kHz)	Capacitance (μF)	Impedance (Ω _{max} /100kHz)		Rated ripple current (mArms/105°C/100kHz)
			20°C	-10°C			20°C	-10°C			20°C	-10°C	
5×11.5	E11	33	0.50	1.0	175	22	0.90	1.8	155	12	1.9	4.0	145
6.3×11.5	F11	56	0.25	0.50	290	47	0.45	0.90	260	22	1.0	2.0	240
6.3×15	F15	100	0.18	0.36	400	68	0.31	0.62	360	39	0.61	1.4	330
8×12	H12	150	0.12	0.24	555	100	0.22	0.44	485	68	0.34	0.75	405
8×15	H15	220	0.090	0.18	730	120	0.16	0.32	635	100	0.27	0.65	535
8×20	H20	270	0.080	0.16	810	180	0.12	0.24	730	150	0.21	0.52	690
10×12.5	J12	220	0.090	0.18	760	120	0.16	0.32	620	100	0.255	0.510	540
10×16	J16	330	0.068	0.136	1,050	180	0.13	0.26	850	120	0.190	0.380	600
10×20	J20	470	0.052	0.104	1,220	220	0.088	0.18	1,050	180	0.145	0.290	890
10×25	J25	560	0.045	0.090	1,440	330	0.073	0.15	1,250	220	0.130	0.260	1,050
10×30	J30	680	0.037	0.074	1,690	390	0.054	0.11	1,500	330	0.090	0.180	1,300
12.5×20	K20	680	0.038	0.076	1,660	390	0.059	0.12	1,480	330	0.085	0.170	1,290
12.5×25	K25	1,000	0.030	0.060	1,950	560	0.044	0.088	1,840	390	0.070	0.140	1,720
12.5×30	K30	1,200	0.025	0.050	2,310	680	0.039	0.078	2,220	470	0.055	0.110	2,090
12.5×35	K35	1,500	0.022	0.044	2,510	820	0.033	0.066	2,290	680	0.047	0.094	2,270
12.5×40	K40	1,800	0.017	0.034	2,870	1,000	0.029	0.058	2,500	820	0.042	0.084	2,560
16×20	L20	1,200	0.029	0.058	2,210	680	0.048	0.096	1,840	470	0.059	0.120	1,770
16×25	L25	1,800	0.022	0.044	2,560	1,000	0.034	0.068	2,240	680	0.050	0.100	2,160
16×30	L30	2,200	0.019	0.038	3,010	1,200	0.028	0.056	2,700	820	0.043	0.086	2,670
16×35	L35	2,700	0.017	0.034	3,150	1,500	0.025	0.050	2,800	1,000	0.036	0.072	2,770
16×40	L40	3,300	0.015	0.030	3,710	1,800	0.021	0.042	3,200	1,200	0.030	0.060	2,850
18×20	M20	1,800	0.028	0.056	2,490	820	0.042	0.084	1,980	680	0.055	0.110	2,290
18×25	M25	2,200	0.020	0.040	2,740	1,200	0.029	0.058	2,610	820	0.043	0.086	2,590
18×30	M30	2,700	0.018	0.036	3,330	1,800	0.025	0.050	3,000	1,200	0.032	0.064	2,950
18×35	M35	3,300	0.016	0.032	3,680	2,200	0.023	0.046	3,100	1,500	0.030	0.060	3,100
18×40	M40	3,900	0.015	0.030	3,800	2,700	0.020	0.040	3,400	1,800	0.025	0.050	3,210

◆RATED RIPPLE CURRENT MULTIPLIERS

●Frequency Multipliers

Capacitance (μF)	Frequency (Hz)			
	120	1k	10k	100k
12 to 180	0.40	0.75	0.90	1.00
220 to 560	0.50	0.85	0.94	1.00
680 to 1,800	0.60	0.87	0.95	1.00
2,200 to 3,900	0.75	0.90	0.95	1.00
4,700 to 18,000	0.85	0.95	0.98	1.00

LXY Series

- Newly innovative electrolyte and internal architecture are employed
- Endurance with ripple current : 105°C 2000 to 8000 hours
- Solvent-proof type, see page 16

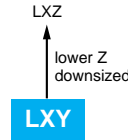

SPECIFICATIONS

Items	Characteristics																								
Category Temperature Range	-55 to +105°C																								
Rated Voltage Range	10 to 63V _{dc}																								
Capacitance Tolerance	±20% (M) (at 20°C, 120Hz)																								
Leakage Current	I = 0.01CV or 3μA, whichever is greater. Where, I : Max. leakage current (μA), C : Nominal capacitance (μF), V : Rated voltage (V) (at 20°C after 2 minutes)																								
Dissipation Factor (tanδ)	<table border="1"> <tr> <td>Rated voltage (V_{dc})</td> <td>10V</td> <td>16V</td> <td>25V</td> <td>35V</td> <td>50V</td> <td>63V</td> </tr> <tr> <td>tanδ (Max.)</td> <td>0.19</td> <td>0.16</td> <td>0.14</td> <td>0.12</td> <td>0.10</td> <td>0.10</td> </tr> </table> <p>When nominal capacitance exceeds 1000μF, add 0.02 to the value above for each 1000μF increase. (at 20°C, 120Hz)</p>	Rated voltage (V _{dc})	10V	16V	25V	35V	50V	63V	tanδ (Max.)	0.19	0.16	0.14	0.12	0.10	0.10										
Rated voltage (V _{dc})	10V	16V	25V	35V	50V	63V																			
tanδ (Max.)	0.19	0.16	0.14	0.12	0.10	0.10																			
Low Temperature Characteristics (Max. Impedance Ratio)	<table border="1"> <tr> <td>Z(-55°C)/Z(+20°C)</td> <td>10V_{dc} to 50V_{dc} : 3max.</td> </tr> <tr> <td></td> <td>63V_{dc} : 6max.</td> </tr> </table> <p>(at 120Hz)</p>	Z(-55°C)/Z(+20°C)	10V _{dc} to 50V _{dc} : 3max.		63V _{dc} : 6max.																				
Z(-55°C)/Z(+20°C)	10V _{dc} to 50V _{dc} : 3max.																								
	63V _{dc} : 6max.																								
Endurance	<p>The following specifications shall be satisfied when the capacitors are restored to 20°C after subjected to DC voltage with the rated ripple current is applied for the specified period of time at 105°C.</p> <table border="1"> <tr> <td>Time</td> <td>φ5 & 6.3 : 2000hours</td> <td>φ8 : 3000hours</td> <td>φ10 : 5000hours</td> <td>φ12.5 : 7000hours</td> <td>φ16 & 18 : 8000hours</td> </tr> <tr> <td>Capacitance change</td> <td colspan="5">≤±20% of the initial value</td> </tr> <tr> <td>DF (tanδ)</td> <td colspan="5">≤200% of the initial specified value</td> </tr> <tr> <td>Leakage current</td> <td colspan="5">≤The initial specified value</td> </tr> </table>	Time	φ5 & 6.3 : 2000hours	φ8 : 3000hours	φ10 : 5000hours	φ12.5 : 7000hours	φ16 & 18 : 8000hours	Capacitance change	≤±20% of the initial value					DF (tanδ)	≤200% of the initial specified value					Leakage current	≤The initial specified value				
Time	φ5 & 6.3 : 2000hours	φ8 : 3000hours	φ10 : 5000hours	φ12.5 : 7000hours	φ16 & 18 : 8000hours																				
Capacitance change	≤±20% of the initial value																								
DF (tanδ)	≤200% of the initial specified value																								
Leakage current	≤The initial specified value																								
Shelf Life	<p>The following specifications shall be satisfied when the capacitors are restored to 20°C after exposing them for 1000 hours at 105°C without voltage applied.</p> <table border="1"> <tr> <td>Capacitance change</td> <td>≤±20% of the initial value</td> </tr> <tr> <td>DF (tanδ)</td> <td>≤200% of the initial specified value</td> </tr> <tr> <td>Leakage current</td> <td>≤The initial specified value</td> </tr> </table>	Capacitance change	≤±20% of the initial value	DF (tanδ)	≤200% of the initial specified value	Leakage current	≤The initial specified value																		
Capacitance change	≤±20% of the initial value																								
DF (tanδ)	≤200% of the initial specified value																								
Leakage current	≤The initial specified value																								

DIMENSIONS (Radial Lead Type=VB) [mm]

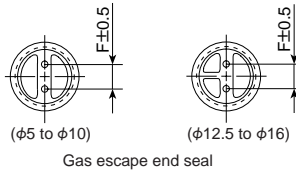
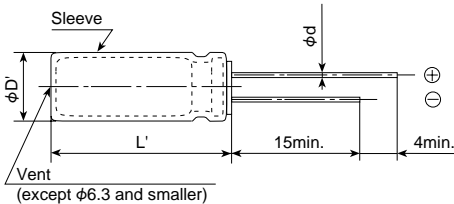

φD	5	6.3	8	10	12.5	16
φd	0.5	0.5	0.6	0.6	0.6	0.8
F	2.0	2.5	3.5	5.0	5.0	7.5
φD'	φD+0.5max.					
L'	L+1.5max.					

PART NUMBERING SYSTEM

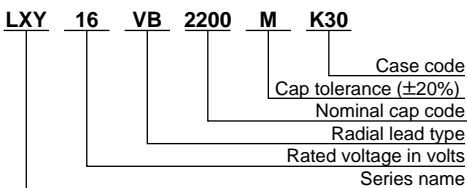

Capacitance	Code
4.7μF	4R7
10μF	10
100μF	100
2200μF	2200

◆STANDARD RATINGS

φDXL (mm) / Case code		V _{dc}		10			16			25			35				
		Capacitance (μF)	Impedance (Ω _{max} /100kHz)		Rated ripple current (mA _{rms} /105°C/100kHz)	Capacitance (μF)	Impedance (Ω _{max} /100kHz)		Rated ripple current (mA _{rms} /105°C/100kHz)	Capacitance (μF)	Impedance (Ω _{max} /100kHz)		Rated ripple current (mA _{rms} /105°C/100kHz)	Capacitance (μF)	Impedance (Ω _{max} /100kHz)		Rated ripple current (mA _{rms} /105°C/100kHz)
			20°C	-10°C			20°C	-10°C			20°C	-10°C			20°C	-10°C	
5X11.5	E11	82	0.75	1.5	163	56	0.75	1.5	163	39	0.75	1.5	163	27	0.75	1.5	163
6.3X11.5	F11	180	0.35	0.70	273	120	0.35	0.70	273	82	0.35	0.70	273	56	0.35	0.70	273
6.3X15	F15	220	0.25	0.50	390	180	0.25	0.50	390	120	0.25	0.50	390	82	0.25	0.50	390
8X12	H12	330	0.17	0.34	445	270	0.17	0.34	445	150	0.17	0.34	445	120	0.17	0.34	445
8X15	H15	470	0.13	0.26	555	330	0.13	0.26	555	220	0.13	0.26	555	180	0.13	0.26	555
8X20	H20	680	0.095	0.19	740	470	0.095	0.19	740	330	0.095	0.19	740	220	0.095	0.19	740
10X12.5	J12	390	0.12	0.24	625	270	0.12	0.24	625	180	0.12	0.24	625	120	0.12	0.24	625
10X16	J16	680	0.084	0.17	825	470	0.084	0.17	825	330	0.084	0.17	825	220	0.084	0.17	825
10X20	J20	1,000	0.062	0.13	1,040	680	0.062	0.13	1,040	470	0.062	0.13	1,040	330	0.062	0.13	1,040
10X25	J25	1,200	0.052	0.11	1,260	820	0.052	0.11	1,260	560	0.052	0.11	1,260	390	0.052	0.11	1,260
10X30	J30	1,500	0.044	0.088	1,440	1,200	0.044	0.088	1,440	820	0.044	0.088	1,440	560	0.044	0.088	1,440
12.5X20	K20	1,800	0.046	0.092	1,340	1,200	0.046	0.092	1,340	820	0.046	0.092	1,340	560	0.046	0.092	1,340
12.5X25	K25	2,200	0.034	0.068	1,690	1,500	0.034	0.068	1,690	1,000	0.034	0.068	1,690	680	0.034	0.068	1,690
12.5X30	K30	2,700	0.030	0.060	1,950	2,200	0.030	0.060	1,950	1,500	0.030	0.060	1,950	1,000	0.030	0.060	1,950
12.5X35	K35	3,300	0.024	0.048	2,220	2,700	0.024	0.048	2,220	1,800	0.024	0.048	2,220	1,200	0.024	0.048	2,220
12.5X40	K40	3,900	0.022	0.044	2,390	3,300	0.022	0.044	2,390	2,200	0.022	0.044	2,390	1,500	0.022	0.044	2,390
16X20	L20	3,300	0.038	0.076	1,630	2,200	0.038	0.076	1,630	1,500	0.038	0.076	1,630	1,000	0.038	0.076	1,630
16X25	L25	3,900	0.028	0.056	2,070	2,700	0.028	0.056	2,070	1,800	0.028	0.056	2,070	1,200	0.028	0.056	2,070
16X30	L30	5,600	0.025	0.050	2,350	3,900	0.025	0.050	2,350	2,700	0.025	0.050	2,350	1,800	0.025	0.050	2,350
16X35	L35	6,800	0.022	0.044	2,550	4,700	0.022	0.044	2,550	3,300	0.022	0.044	2,550	2,200	0.022	0.044	2,550
16X40	L40	8,200	0.018	0.036	2,900	5,600	0.018	0.036	2,900	3,900	0.018	0.036	2,900	2,700	0.018	0.036	2,900

φDXL (mm) / Case code		V _{dc}		50			63		
		Capacitance (μF)	Impedance (Ω _{max} /100kHz)		Rated ripple current (mA _{rms} /105°C/100kHz)	Capacitance (μF)	Impedance (Ω _{max} /100kHz)		Rated ripple current (mA _{rms} /105°C/100kHz)
			20°C	-10°C			20°C	-10°C	
5X11.5	E11	18	1.2	2.4	129	10	1.9	4.8	103
6.3X11.5	F11	39	0.54	1.1	219	18	1.0	2.5	161
6.3X15	F15	56	0.34	0.68	310	33	0.61	1.6	233
8X12	H12	68	0.30	0.60	340	47	0.47	1.2	274
8X15	H15	82	0.20	0.40	470	68	0.34	0.85	360
8X20	H20	120	0.14	0.28	610	82	0.21	0.53	500
10X12.5	J12	82	0.20	0.40	480	56	0.27	0.68	418
10X16	J16	120	0.13	0.26	755	68	0.21	0.53	525
10X20	J20	180	0.088	0.18	945	120	0.16	0.40	650
10X25	J25	220	0.073	0.15	1,150	150	0.13	0.33	783
10X30	J30	330	0.054	0.11	1,260	180	0.10	0.25	960
12.5X20	K20	330	0.059	0.12	1,190	220	0.11	0.28	870
12.5X25	K25	470	0.044	0.088	1,490	270	0.074	0.19	1,150
12.5X30	K30	560	0.039	0.078	1,720	390	0.068	0.17	1,280
12.5X35	K35	680	0.033	0.066	1,890	470	0.063	0.16	1,390
12.5X40	K40	820	0.029	0.058	2,030	560	0.051	0.13	1,530
16X20	L20	680	0.050	0.10	1,420	330	0.085	0.22	1,100
16X25	L25	820	0.034	0.068	1,880	470	0.055	0.14	1,480
16X30	L30	1,000	0.030	0.060	2,150	680	0.046	0.12	1,720
16X35	L35	1,200	0.027	0.054	2,320	820	0.040	0.10	1,910
16X40	L40	1,500	0.024	0.048	2,540	1,000	0.036	0.090	2,070

◆RATED RIPPLE CURRENT MULTIPLIERS

● Frequency Multipliers

Capacitance (μF)	Frequency (Hz)			
	120	1k	10k	100k
10 to 180	0.40	0.75	0.90	1.00
220 to 560	0.50	0.85	0.94	1.00
680 to 1800	0.60	0.87	0.95	1.00
2200 to 3900	0.75	0.90	0.95	1.00
4700 to 8200	0.85	0.95	0.98	1.00

The following case sizes are also available upon request : φ4×7mm, φ5×7mm, φ5×15mm, φ6.3×7mm φ12.5×15mm, φ16×15mm, and φ18×15mm.

LXV Series

- Low impedance
- Endurance with ripple current: 105°C 2000 to 5000 hours
- Solvent-proof type, see page 16

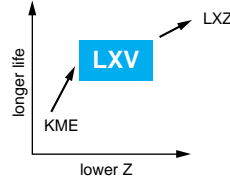

SPECIFICATIONS

Items	Characteristics										
Category											
Temperature Range	-55 to +105°C										
Rated Voltage Range	6.3 to 100V _{dc}										
Capacitance Tolerance	±20% (M) (at 20°C, 120Hz)										
Leakage Current	I = 0.01CV or 3µA, whichever is greater. Where, I : Max. leakage current (µA), C : Nominal capacitance (µF), V : Rated voltage (V) (at 20°C after 2 minutes)										
Dissipation Factor (tanδ)	Rated voltage (V _{dc})	6.3V	10V	16V	25V	35V	50V	63V	80V	100V	
	tanδ (Max.)	0.22	0.19	0.16	0.14	0.12	0.10	0.10	0.09	0.08	
	When nominal capacitance exceeds 1000µF, add 0.02 to the value above for each 1000µF increase. (at 20°C, 120Hz)										
Low Temperature Characteristics	Capacitance change ΔC (-55°C / +20°C)	≤ ±30%									
	Max. impedance ratio (-55°C / +20°C)	3max. (6.3V _{dc} : 4max.) (at 120Hz)									
Endurance	The following specifications shall be satisfied when the capacitors are restored to 20°C after subjected to DC voltage with the rated ripple current is applied for the specified period of time at 105°C.										
	Time	φ5 to φ6.3 : 2000hours φ8 & 10 : 3000hours φ12.5 to φ18 : 5000hours									
	Capacitance change	≤ ±20% of the initial value									
	DF (tanδ)	≤ 200% of the initial specified value									
	Leakage current	≤ The initial specified value									
Shelf Life	The following specifications shall be satisfied when the capacitors are restored to 20°C after exposing them for 1000 hours at 105°C without voltage applied.										
	Capacitance change	≤ ±20% of the initial value									
	DF (tanδ)	≤ 200% of the initial specified value									
	Leakage current	≤ The initial specified value									

DIMENSIONS (Radial Lead Type=VB) [mm]

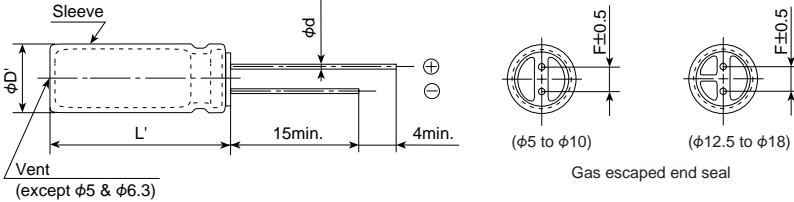

φD	5	6.3	8	10	12.5	16	18
φd	0.5	0.5	0.6	0.6	0.6	0.8	0.8
F	2.0	2.5	3.5	5.0	5.0	7.5	7.5
φD'	φD+0.5max.						
L'	L+1.5max.						

PART NUMBERING SYSTEM

LXV 6.3 VB 1200 M J20

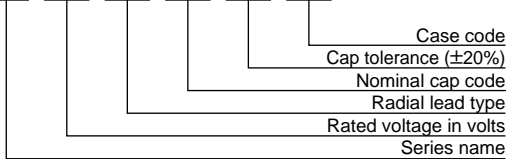

Capacitance	Code
4.7µF	4R7
10µF	10
100µF	100
2200µF	2200

◆ **STANDARD RATINGS**

φDXL	Case code	V _{dc}		6.3			10			16			
		Capacitance (μF)	Impedance (Ω _{max} /100kHz)		Rated ripple current (mA _{rms} / 105°C 100kHz)	Capacitance (μF)	Impedance (Ω _{max} /100kHz)		Rated ripple current (mA _{rms} / 105°C 100kHz)	Capacitance (μF)	Impedance (Ω _{max} /100kHz)		Rated ripple current (mA _{rms} / 105°C 100kHz)
			20°C	-10°C			20°C	-10°C			20°C	-10°C	
5×11.5	E11	120	0.72	1.8	165	82	0.72	1.8	165	56	0.72	1.8	165
6.3×11.5	F11	220	0.38	0.95	255	180	0.38	0.95	255	120	0.38	0.95	255
6.3×15	F15	330	0.27	0.68	330	270	0.27	0.68	330	180	0.27	0.68	330
8×12	H12	390	0.20	0.50	415	330	0.20	0.50	415	270	0.20	0.50	415
8×15	H15	560	0.16	0.40	495	470	0.16	0.40	495	330	0.16	0.40	495
8×20	H20	820	0.11	0.28	640	680	0.11	0.28	640	470	0.11	0.28	640
10×12.5	J12	470	0.12	0.30	635	390	0.12	0.30	635	270	0.12	0.30	635
10×16	J16	680	0.084	0.21	825	680	0.084	0.21	825	470	0.084	0.21	825
10×20	J20	1,200	0.062	0.16	1,060	1,000	0.062	0.16	1,060	680	0.062	0.16	1,060
10×25	J25	1,500	0.052	0.13	1,260	1,200	0.052	0.13	1,260	820	0.052	0.13	1,260
10×30	J30	2,200	0.044	0.11	1,450	1,500	0.044	0.11	1,450	1,200	0.044	0.11	1,450
12.5×20	K20	2,200	0.046	0.12	1,360	1,800	0.046	0.12	1,360	1,200	0.046	0.12	1,360
12.5×25	K25	2,700	0.034	0.085	1,700	2,200	0.034	0.085	1,700	1,500	0.034	0.085	1,700
12.5×30	K30	3,900	0.030	0.075	1,980	2,700	0.030	0.075	1,980	2,200	0.030	0.075	1,980
12.5×35	K35	4,700	0.027	0.068	2,230	3,300	0.027	0.068	2,230	2,700	0.027	0.068	2,230
12.5×40	K40	5,600	0.024	0.060	2,460	3,900	0.024	0.060	2,460	3,300	0.024	0.060	2,460
16×20	L20	3,900	0.038	0.095	1,770	3,300	0.038	0.095	1,770	2,200	0.038	0.095	1,770
16×25	L25	5,600	0.028	0.070	2,190	3,900	0.028	0.070	2,190	2,700	0.028	0.070	2,190
16×30	L30	6,800	0.025	0.063	2,510	5,600	0.025	0.063	2,510	3,900	0.025	0.063	2,510
16×35	L35	8,200	0.022	0.055	2,770	6,800	0.022	0.055	2,770	4,700	0.022	0.055	2,770
16×40	L40	10,000	0.018	0.045	3,110	8,200	0.018	0.045	3,110	5,600	0.018	0.045	3,110
18×20	M20	5,600	0.036	0.090	1,940	3,900	0.036	0.090	1,940	3,300	0.036	0.090	1,940
18×25	M25	6,800	0.027	0.068	2,350	4,700	0.027	0.068	2,350	3,900	0.027	0.068	2,350
18×30	M30	10,000	0.024	0.060	2,720	6,800	0.024	0.060	2,720	4,700	0.024	0.060	2,720
18×35	M35	12,000	0.021	0.053	3,050	8,200	0.021	0.053	3,050	6,800	0.021	0.053	3,050
18×40	M40	15,000	0.017	0.043	3,300	10,000	0.017	0.043	3,300	8,200	0.017	0.043	3,300

φDXL	Case code	V _{dc}		25			35			50			
		Capacitance (μF)	Impedance (Ω _{max} /100kHz)		Rated ripple current (mA _{rms} / 105°C 100kHz)	Capacitance (μF)	Impedance (Ω _{max} /100kHz)		Rated ripple current (mA _{rms} / 105°C 100kHz)	Capacitance (μF)	Impedance (Ω _{max} /100kHz)		Rated ripple current (mA _{rms} / 105°C 100kHz)
			20°C	-10°C			20°C	-10°C			20°C	-10°C	
5×11.5	E11	39	0.72	1.8	165	27	0.72	1.8	165	18	1.1	3.3	165
6.3×11.5	F11	82	0.38	0.95	255	56	0.38	0.95	255	39	0.56	1.6	255
6.3×15	F15	120	0.27	0.68	330	82	0.27	0.68	330	56	0.41	1.2	310
8×12	H12	150	0.20	0.50	415	120	0.20	0.50	415	68	0.29	0.84	415
8×15	H15	220	0.16	0.40	495	180	0.16	0.40	495	82	0.24	0.72	505
8×20	H20	330	0.11	0.28	640	220	0.11	0.28	640	120	0.18	0.52	610
10×12.5	J12	180	0.12	0.30	635	120	0.12	0.30	635	82	0.16	0.40	530
10×16	J16	330	0.084	0.21	825	220	0.084	0.21	825	120	0.12	0.30	755
10×20	J20	470	0.062	0.16	1,060	330	0.062	0.16	1,060	180	0.088	0.22	945
10×25	J25	560	0.052	0.13	1,260	390	0.052	0.13	1,260	220	0.068	0.17	1,150
10×30	J30	820	0.044	0.11	1,450	560	0.044	0.11	1,450	330	0.059	0.15	1,260
12.5×20	K20	820	0.046	0.12	1,360	560	0.046	0.12	1,360	330	0.059	0.15	1,190
12.5×25	K25	1,000	0.034	0.085	1,700	680	0.034	0.085	1,700	470	0.045	0.11	1,500
12.5×30	K30	1,500	0.030	0.075	1,980	1,000	0.030	0.075	1,980	560	0.039	0.098	1,720
12.5×35	K35	1,800	0.027	0.068	2,230	1,200	0.027	0.068	2,230	680	0.033	0.083	1,900
12.5×40	K40	2,200	0.024	0.060	2,460	1,500	0.024	0.060	2,460	820	0.029	0.073	2,120
16×20	L20	1,500	0.038	0.095	1,770	1,000	0.038	0.095	1,770	680	0.043	0.11	1,500
16×25	L25	1,800	0.028	0.070	2,190	1,200	0.028	0.070	2,190	820	0.033	0.083	1,880
16×30	L30	2,700	0.025	0.063	2,510	1,800	0.025	0.063	2,510	1,000	0.029	0.073	2,150
16×35	L35	3,300	0.022	0.055	2,770	2,200	0.022	0.055	2,770	1,200	0.025	0.063	2,320
16×40	L40	3,900	0.018	0.045	3,110	2,700	0.018	0.045	3,110	1,500	0.021	0.053	2,650
18×20	M20	2,200	0.036	0.090	1,940	1,500	0.036	0.090	1,940	820	0.039	0.098	1,660
18×25	M25	2,700	0.027	0.068	2,350	1,800	0.027	0.068	2,350	1,000	0.030	0.075	2,020
18×30	M30	3,300	0.024	0.060	2,720	2,200	0.024	0.060	2,720	1,500	0.026	0.065	2,340
18×35	M35	3,900	0.021	0.053	3,050	2,700	0.021	0.053	3,050	1,800	0.023	0.058	2,620
18×40	M40	4,700	0.017	0.043	3,300	3,300	0.017	0.043	3,300	2,200	0.020	0.050	2,790

◆STANDARD RATINGS

φD×L	Case code	V _{dc}		63			80			100			
		Capacitance (μF)	Impedance (Ω _{max} /100kHz)		Rated ripple current (mA _{rms} / 105°C / 100kHz)	Capacitance (μF)	Impedance (Ω _{max} /100kHz)		Rated ripple current (mA _{rms} / 105°C / 100kHz)	Capacitance (μF)	Impedance (Ω _{max} /100kHz)		Rated ripple current (mA _{rms} / 105°C / 100kHz)
			20°C	-10°C			20°C	-10°C			20°C	-10°C	
5×11.5	E11	12	1.9	4.8	100	8.2	1.9	5.1	100	5.6	1.9	5.1	100
6.3×11.5	F11	27	1.1	2.8	160	18	1.1	3.0	150	12	1.1	3.0	150
6.3×15	F15	39	0.62	1.6	230	27	0.62	1.7	220	18	0.62	1.7	220
8×12	H12	47	0.49	1.3	275	33	0.53	1.5	275	22	0.53	1.5	275
8×15	H15	68	0.34	0.85	360	47	0.35	0.97	360	33	0.35	0.97	360
8×20	H20	82	0.21	0.53	500	56	0.27	0.74	490	39	0.27	0.74	490
10×12.5	J12	56	0.27	0.68	420	39	0.47	1.3	380	27	0.47	1.3	380
10×16	J16	68	0.21	0.53	523	56	0.33	0.90	500	33	0.33	0.90	500
10×20	J20	120	0.16	0.40	650	82	0.26	0.70	620	56	0.26	0.70	620
10×25	J25	150	0.13	0.33	780	100	0.19	0.52	795	68	0.19	0.52	795
10×30	J30	180	0.10	0.25	960	150	0.15	0.41	955	100	0.15	0.41	955
12.5×20	K20	220	0.11	0.28	870	150	0.15	0.41	890	100	0.15	0.41	890
12.5×25	K25	270	0.074	0.19	1,150	180	0.11	0.30	1,040	120	0.11	0.30	1,040
12.5×30	K30	390	0.068	0.17	1,280	270	0.094	0.26	1,270	180	0.094	0.26	1,270
12.5×35	K35	470	0.063	0.16	1,390	330	0.087	0.24	1,450	220	0.087	0.24	1,450
12.5×40	K40	560	0.051	0.13	1,530	390	0.060	0.17	1,610	270	0.060	0.17	1,610
16×20	L20	390	0.085	0.22	1,100	270	0.11	0.30	1,240	180	0.11	0.30	1,240
16×25	L25	470	0.055	0.14	1,480	330	0.081	0.22	1,440	220	0.081	0.22	1,440
16×30	L30	680	0.046	0.12	1,720	470	0.058	0.16	1,790	330	0.058	0.16	1,790
16×35	L35	820	0.040	0.10	1,910	560	0.052	0.14	2,000	390	0.052	0.14	2,000
16×40	L40	1,000	0.036	0.090	2,070	680	0.041	0.11	2,200	470	0.041	0.11	2,200
18×20	M20	560	0.085	0.22	1,170	390	0.085	0.23	1,450	270	0.085	0.23	1,450
18×25	M25	680	0.055	0.14	1,520	470	0.070	0.19	1,650	330	0.070	0.19	1,650
18×30	M30	820	0.046	0.12	1,770	680	0.058	0.16	1,850	390	0.058	0.16	1,850
18×35	M35	1,000	0.040	0.10	1,970	820	0.052	0.14	1,990	560	0.052	0.14	1,990
18×40	M40	1,200	0.036	0.090	2,130	1,000	0.041	0.11	2,370	680	0.041	0.11	2,370

◆RATED RIPPLE CURRENT MULTIPLIERS

●Frequency Multipliers

Rated voltage (V _{dc})	Case size φD (mm)	Frequency (Hz)			
		120	1k	10k	100k
6.3 & 10	5 to 8	0.65	0.83	0.95	1.00
	10 & 12.5	0.70	0.85	0.96	1.00
	16 & 18	0.85	0.92	0.97	1.00
16 & 25	5 to 8	0.55	0.76	0.91	1.00
	10 & 12.5	0.65	0.83	0.93	1.00
	16 & 18	0.70	0.87	0.96	1.00
35 & 50	5 to 8	0.40	0.66	0.85	1.00
	10 & 12.5	0.50	0.73	0.89	1.00
	16 & 18	0.60	0.81	0.94	1.00
63 to 100	5 to 8	0.20	0.55	0.80	1.00
	10 & 12.5	0.35	0.65	0.85	1.00
	16 & 18	0.50	0.75	0.90	1.00

SXE Series

- Low impedance capacitors, operating temperature range from -55 to 105°C
- Solvent-proof type, see page 16



◆ SPECIFICATIONS

Items	Characteristics	
Category Temperature Range	-55 to +105°C	
Rated Voltage Range	6.3 to 100V _{dc}	
Capacitance Tolerance	±20%(M) (at 20°C, 120Hz)	
Leakage Current	I=0.03CV (after 1 minute at 20°C) Where: I:Max. leakage current (μA), C:Nominal capacitance (μF), V:Rated voltage (V) I=0.01CV (after 2 minutes at 20°C)	
Dissipation factor (tanδ)	Rated voltage(V _{dc})	6.3 10 16 25 35 50 63 80 100
	tanδ (Max.)	0.22 0.19 0.16 0.14 0.12 0.10 0.08 0.08 0.07
Endurance	When nominal capacitance exceeds 1000μF, add 0.02 to the value above for each 1000μF increase. (at 20°C, 120Hz)	
	The following specifications shall be satisfied when the capacitors are restored to 20°C after the rated voltage is applied for the specified period of lifetime at 105°C.	
	Lifetime	1,000 hours (φ4 to 8) 2,000 hours (φ10 to 18)
	Capacitance change	≤±20% of the initial value ≤±20% of the initial value
	DF (tanδ)	≤200% of the initial specified value ≤200% of the initial specified value
Shelf Life	The following specifications shall be satisfied when the capacitors are restored to 20°C after exposing them for 1,000 hours at 105°C without voltage applied.	
	Capacitance change	≤±20% of the initial value
	DF (tanδ)	≤150% of the initial specified value
	Leakage current	≤the initial specified value

◆ DIMENSIONS (Radial Lead Type=VB) [mm]

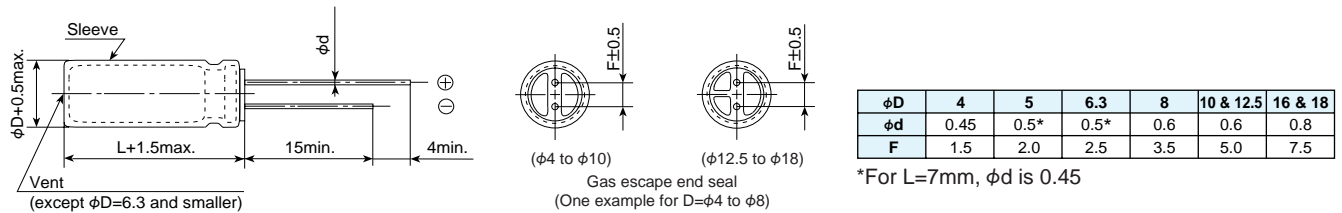

◆ PART NUMBERING SYSTEM

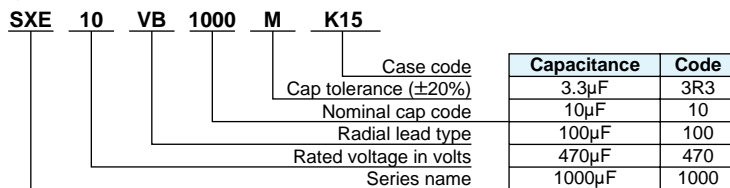

◆ CASE CODE

L(mm) \ φD(mm)	7	11.5	12	12.5	15	20	25	30	35	40
4	D07	D11								
5	E07	E11			E15					
6.3	F07	F11			F15					
8			H12		H15	H20				
10				J12	J15	J20	J25	J30		
12.5					K15	K20	K25	K30	K35	K40
16					L15	L20	L25	L30	L35	L40
18					M15	M20	M25	M30	M35	M40

◆STANDARD RATINGS

Case size φDXL (mm)	Items	V _{dc}					10					16				
		6.3		10			6.3		10			6.3		10		
		Capacitance (μF)	Impedance (Ω _{max}) (20°C/100kHz) (-10°C/100kHz)	Rated ripple current (mArms) (105°C/100kHz) (105°C/120Hz)		Capacitance (μF)	Impedance (Ω _{max}) (20°C/100kHz) (-10°C/100kHz)	Rated ripple current (mArms) (105°C/100kHz) (105°C/120Hz)		Capacitance (μF)	Impedance (Ω _{max}) (20°C/100kHz) (-10°C/100kHz)	Rated ripple current (mArms) (105°C/100kHz) (105°C/120Hz)				
4X7	27	5.5	14.3	50	25	22	5.4	14.0	50	25	15	5.3	13.8	50	25	
4X11.5	68	2.2	5.7	102	74	47	2.2	5.6	102	74	33	2.1	5.5	102	51	
5X7	56	3.4	8.8	75	68	39	3.3	8.6	75	68	27	3.3	8.6	75	49	
5X11.5	120	1.3	3.4	154	108	82	1.3	3.4	154	108	56	1.3	3.4	154	108	
5X15	150	0.92	2.4	210	147	120	0.91	2.4	210	147	82	0.89	2.3	210	147	
6.3X7	120	1.4	3.6	140	98	82	1.4	3.6	140	98	56	1.4	3.6	140	98	
6.3X11.5	220	0.61	1.6	260	182	180	0.59	1.5	260	182	120	0.58	1.5	260	182	
6.3X15	330	0.40	1.0	350	245	270	0.39	1.0	350	245	180	0.38	0.99	350	245	
8X12	390	0.34	0.88	400	320	330	0.33	0.86	400	280	220	0.33	0.86	400	280	
8X15	560	0.24	0.62	500	400	470	0.24	0.62	500	400	330	0.23	0.60	500	350	
8X20	820	0.19	0.49	650	520	560	0.18	0.47	650	520	470	0.18	0.47	650	520	
10X12.5	470	0.28	0.73	510	410	390	0.27	0.70	510	410	270	0.27	0.70	510	360	
10X15	680	0.22	0.57	635	510	560	0.22	0.57	635	510	390	0.21	0.55	635	510	
10X20	1,200	0.14	0.36	860	775	820	0.14	0.36	860	690	680	0.14	0.36	860	690	
10X25	1,500	0.12	0.31	1,030	930	1,200	0.12	0.31	1,030	930	820	0.12	0.31	1,030	825	
10X30	2,200	0.095	0.25	1,150	1,035	1,500	0.093	0.24	1,150	1,035	1,000	0.091	0.24	1,150	920	
12.5X15	1,200	0.12	0.31	970	875	1,000	0.12	0.31	970	780	680	0.12	0.31	970	780	
12.5X20	2,200	0.089	0.23	1,120	1,010	1,800	0.087	0.23	1,120	1,010	1,200	0.086	0.22	1,120	1,010	
12.5X25	2,700	0.075	0.20	1,320	1,190	2,200	0.073	0.19	1,320	1,190	1,500	0.072	0.19	1,320	1,190	
12.5X30	3,900	0.065	0.17	1,540	1,390	2,700	0.064	0.17	1,540	1,390	2,200	0.063	0.16	1,540	1,390	
12.5X35	4,700	0.053	0.14	1,770	1,595	3,300	0.052	0.14	1,770	1,595	2,700	0.051	0.13	1,770	1,595	
12.5X40	5,600	0.046	0.12	1,980	1,785	3,900	0.045	0.12	1,980	1,785	3,300	0.045	0.12	1,980	1,785	
16X15	2,200	0.10	0.26	1,100	990	1,500	0.10	0.26	1,100	990	1,200	0.099	0.26	1,100	990	
16X20	3,900	0.076	0.20	1,370	1,235	3,300	0.075	0.20	1,370	1,235	2,200	0.073	0.19	1,370	1,235	
16X25	5,600	0.066	0.17	1,570	1,415	3,900	0.065	0.17	1,570	1,415	2,700	0.064	0.17	1,570	1,415	
16X30	6,800	0.055	0.14	1,810	1,630	4,700	0.054	0.14	1,810	1,630	3,900	0.053	0.14	1,810	1,630	
16X35	8,200	0.047	0.12	2,030	1,830	6,800	0.046	0.12	2,030	1,830	4,700	0.046	0.12	2,030	1,830	
16X40	10,000	0.039	0.10	2,320	2,090	8,200	0.038	0.099	2,320	2,090	5,600	0.037	0.096	2,320	2,090	
18X15	3,300	0.081	0.21	1,280	1,155	2,200	0.080	0.21	1,280	1,150	1,500	0.078	0.20	1,280	1,155	
18X20	5,600	0.063	0.16	1,580	1,425	3,900	0.062	0.16	1,580	1,425	3,300	0.060	0.16	1,580	1,425	
18X25	6,800	0.054	0.14	1,830	1,650	4,700	0.053	0.14	1,830	1,650	3,900	0.052	0.14	1,830	1,650	
18X30	10,000	0.047	0.12	2,030	1,830	6,800	0.046	0.12	2,030	1,830	4,700	0.046	0.12	2,030	1,830	
18X35	12,000	0.042	0.11	2,240	2,020	8,200	0.041	0.11	2,240	2,020	6,800	0.040	0.10	2,240	2,020	
18X40	15,000	0.037	0.096	2,460	2,215	10,000	0.037	0.096	2,460	2,215	8,200	0.036	0.094	2,460	2,215	

Case size φDXL (mm)	Items	V _{dc}					35					50				
		25		35			25		35			25		35		
		Capacitance (μF)	Impedance (Ω _{max}) (20°C/100kHz) (-10°C/100kHz)	Rated ripple current (mArms) (105°C/100kHz) (105°C/120Hz)		Capacitance (μF)	Impedance (Ω _{max}) (20°C/100kHz) (-10°C/100kHz)	Rated ripple current (mArms) (105°C/100kHz) (105°C/120Hz)		Capacitance (μF)	Impedance (Ω _{max}) (20°C/100kHz) (-10°C/100kHz)	Rated ripple current (mArms) (105°C/100kHz) (105°C/120Hz)				
4X7	10	5.3	13.7	50	25	6.8	5.2	13.4	50	25	4.7	5.0	13.0	50	20	
4X11.5	22	2.1	5.5	102	51	15	2.1	5.4	102	51	10	2.0	5.2	102	51	
5X7	22	3.3	8.6	75	45	12	3.2	8.3	75	38	8.2	3.1	8.1	75	38	
5X11.5	39	1.3	3.3	154	108	27	1.2	3.1	154	77	18	1.2	3.1	154	77	
5X15	56	0.88	2.3	210	147	39	0.87	2.3	210	147	27	0.84	2.2	210	105	
6.3X7	39	1.4	3.6	140	98	27	1.3	3.4	140	70	18	1.3	3.4	140	70	
6.3X11.5	82	0.58	1.5	260	182	56	0.57	1.5	260	182	39	0.55	1.4	260	182	
6.3X15	120	0.38	0.99	350	245	82	0.37	0.96	350	245	56	0.36	0.94	350	245	
8X12	150	0.33	0.86	400	280	100	0.32	0.83	400	280	68	0.31	0.81	400	280	
8X15	220	0.23	0.60	500	350	150	0.23	0.60	500	350	82	0.22	0.57	500	350	
8X20	270	0.18	0.47	650	455	220	0.18	0.47	650	455	120	0.17	0.44	650	455	
10X12.5	180	0.26	0.68	510	360	120	0.26	0.68	510	360	82	0.25	0.65	510	360	
10X15	270	0.21	0.55	635	445	180	0.21	0.55	635	445	100	0.20	0.52	635	445	
10X20	470	0.14	0.36	860	690	330	0.13	0.34	860	605	180	0.13	0.34	860	605	
10X25	560	0.12	0.31	1,030	825	390	0.11	0.29	1,030	825	220	0.11	0.29	1,030	725	
10X30	680	0.090	0.23	1,150	920	470	0.089	0.23	1,150	920	330	0.086	0.22	1,150	805	
12.5X15	470	0.12	0.31	970	780	330	0.11	0.29	970	680	180	0.11	0.29	970	680	
12.5X20	820	0.085	0.22	1,120	900	560	0.083	0.22	1,120	900	330	0.081	0.22	1,120	785	
12.5X25	1,000	0.071	0.18	1,320	1,060	680	0.070	0.18	1,320	1,060	470	0.068	0.19	1,320	1,060	
12.5X30	1,500	0.062	0.16	1,540	1,390	1,000	0.061	0.16	1,540	1,390	560	0.059	0.16	1,540	1,235	
12.5X35	1,800	0.050	0.13	1,770	1,595	1,200	0.049	0.13	1,770	1,595	680	0.048	0.14	1,770	1,420	
12.5X40	2,200	0.044	0.11	1,980	1,785	1,500	0.043	0.11	1,980	1,785	820	0.042	0.12	1,980	1,585	
16X15	820	0.098	0.25	1,100	880	560	0.096	0.25	1,100	880	330	0.093	0.20	1,100	770	
16X20	1,500	0.072	0.19	1,370	1,235	1,000	0.071	0.18	1,370	1,100	680	0.069	0.15	1,370	1,100	
16X25	1,800	0.063	0.16	1,570	1,415	1,200	0.062	0.16	1,570	1,415	820	0.060	0.13	1,570	1,260	
16X30	2,700	0.053	0.14	1,810	1,630	1,800	0.052	0.14	1,810	1,630	1,000	0.050	0.13	1,810	1,450	
16X35	3,300	0.045	0.12	2,030	1,830	2,200	0.044	0.11	2,030	1,830	1,200	0.043	0.11	2,030	1,830	
16X40	3,900	0.037	0.096	2,320	2,090	2,700	0.036	0.094	2,320	2,090	1,500	0.035	0.091	2,320	2,090	
18X15	1,200	0.078	0.20	1,280	1,155	820	0.076	0.20	1,280	1,155	470	0.074	0.19	1,280	1,025	
18X20	2,200	0.060	0.16	1,580	1,425	1,500	0.059	0.15	1,580	1,425	820	0.057	0.15	1,580	1,265	
18X25	2,700	0.051	0.13	1,830	1,650	1,800	0.050	0.13	1,830	1,650	1,000	0.049	0.13	1,830	1,465	
18X30	3,300	0.045	0.12	2,030	1,830	2,200	0.044	0.11	2,030	1,830	1,500	0.043	0.11	2,030	1,830	
18X35	3,900	0.040	0.10	2,240	2,020	2,700	0.039	0.10	2,240	2,020	1,800	0.038	0.099	2,240	2,020	
18X40	4,700	0.036	0.094	2,460	2,215	3,300	0.035	0.091	2,460	2,215	2,200	0.034	0.088	2,460	2,215	

◆STANDARD RATINGS

Case size φDXL (mm)	Items	63					80					100				
		Capacitance (μF)	Impedance (Ωmax)		Rated ripple current (mArms)		Capacitance (μF)	Impedance (Ωmax)		Rated ripple current (mArms)		Capacitance (μF)	Impedance (Ωmax)		Rated ripple current (mArms)	
			20°C/100kHz	-10°C/100kHz	105°C/100kHz	105°C/120Hz		20°C/100kHz	-10°C/100kHz	105°C/100kHz	105°C/120Hz		20°C/100kHz	-10°C/100kHz	105°C/100kHz	105°C/120Hz
4X7	3.3	11.2	30.2	38	15	2.2	11.0	29.7	38	15	1.5	10.8	29.2	38	15	
4X11.5	6.8	4.3	11.6	73	37	4.7	4.2	11.3	73	29	3.3	4.1	11.1	73	29	
5X7	5.6	5.1	13.8	61	31	3.9	5.0	13.5	61	24	2.7	4.9	13.2	61	24	
5X11.5	12	2.0	5.4	124	62	8.2	1.9	5.2	124	62	5.6	1.9	5.1	124	62	
5X15	18	1.4	3.8	170	85	12	1.4	3.7	170	85	8.2	1.3	3.6	170	85	
6.3X7	12	3.0	8.1	95	48	8.2	2.9	7.8	95	48	5.6	2.8	7.6	95	48	
6.3X11.5	27	1.2	3.2	180	90	18	1.1	3.0	180	90	12	1.1	3.0	180	90	
6.3X15	39	0.66	1.8	270	190	27	0.64	1.7	270	135	18	0.62	1.7	270	135	
8X12	47	0.56	1.5	305	215	33	0.54	1.5	305	155	22	0.53	1.4	305	155	
8X15	68	0.36	0.97	410	290	47	0.36	0.97	410	290	33	0.35	0.95	410	205	
8X20	82	0.22	0.57	605	425	56	0.28	0.74	605	425	39	0.27	0.73	605	425	
10X12.5	56	0.50	1.4	380	270	39	0.49	1.3	380	270	27	0.48	1.3	380	190	
10X15	68	0.35	0.95	500	350	56	0.34	0.90	500	350	33	0.33	0.89	500	250	
10X20	120	0.27	0.74	620	435	82	0.26	0.71	620	435	56	0.26	0.70	620	435	
10X25	150	0.20	0.53	795	560	100	0.19	0.51	795	560	68	0.19	0.50	795	560	
10X30	180	0.16	0.42	955	670	150	0.15	0.41	955	670	100	0.15	0.40	955	670	
12.5X15	150	0.25	0.67	640	450	100	0.24	0.64	640	450	68	0.23	0.63	640	450	
12.5X20	220	0.16	0.42	890	625	150	0.15	0.41	890	625	100	0.15	0.40	890	625	
12.5X25	270	0.14	0.38	1,040	730	180	0.14	0.37	1,040	730	120	0.13	0.36	1,040	730	
12.5X30	390	0.11	0.29	1,270	1,020	270	0.10	0.28	1,270	890	180	0.10	0.27	1,270	890	
12.5X35	470	0.091	0.25	1,450	1,160	330	0.088	0.24	1,450	1,015	220	0.087	0.23	1,450	1,015	
12.5X40	560	0.080	0.22	1,610	1,290	390	0.076	0.21	1,610	1,290	270	0.074	0.20	1,610	1,130	
16X15	220	0.15	0.41	960	675	180	0.14	0.38	960	675	120	0.14	0.38	960	675	
16X20	390	0.12	0.32	1,240	995	270	0.11	0.31	1,240	870	180	0.11	0.30	1,240	870	
16X25	470	0.091	0.25	1,440	1,155	330	0.088	0.24	1,440	1,010	220	0.086	0.23	1,440	1,010	
16X30	680	0.065	0.18	1,790	1,435	470	0.063	0.17	1,790	1,435	330	0.062	0.17	1,790	1,255	
16X35	820	0.056	0.15	2,000	1,600	560	0.054	0.15	2,000	1,600	390	0.059	0.16	1,990	1,595	
16X40	1,000	0.049	0.13	2,200	1,780	680	0.048	0.13	2,200	1,780	470	0.047	0.13	2,200	1,780	
18X15	330	0.13	0.35	1,130	795	220	0.13	0.34	1,130	795	150	0.12	0.33	1,130	795	
18X20	560	0.091	0.25	1,450	1,160	390	0.088	0.24	1,450	1,160	270	0.086	0.23	1,450	1,015	
18X25	680	0.078	0.21	1,650	1,320	470	0.075	0.20	1,650	1,320	330	0.074	0.20	1,650	1,155	
18X30	820	0.065	0.18	1,850	1,480	680	0.063	0.17	1,850	1,480	390	0.062	0.17	1,850	1,480	
18X35	1,000	0.061	0.16	1,990	1,595	820	0.060	0.16	1,990	1,595	560	0.053	0.14	2,000	1,600	
18X40	1,200	0.046	0.12	2,370	2,135	1,000	0.044	0.12	2,370	1,900	680	0.043	0.12	2,370	1,900	

◆RATED RIPPLE CURRENT MULTIPLIERS
●Frequency Multipliers

Capacitance (μF)	Frequency (Hz)					
	50	120	300	1k	10k	100k
1.5 to 4.7	0.30	0.40	0.50	0.70	0.80	1.00
5.6 to 33	0.40	0.50	0.60	0.80	0.90	1.00
39 to 330	0.60	0.70	0.80	0.90	0.95	1.00
390 to 1,000	0.65	0.80	0.90	0.98	1.00	1.00
1,200	0.80	0.90	0.95	0.98	1.00	1.00

LXJ Series

- Low impedance
- Endurance with ripple current: 105°C 2000 to 5000 hours
- Solvent-proof type, see page 16



◆ SPECIFICATIONS

Items	Characteristics	
Category	-55 to +105°C	
Temperature Range		
Rated Voltage Range	6.3 to 50V _{dc}	
Capacitance Tolerance	±20% (M) (at 20°C, 120Hz)	
Leakage Current	I=0.03CV or 4μA, whichever is greater. (at 20°C after 1 minute) I=0.01CV or 3μA, whichever is greater. (at 20°C after 2 minutes) Where, I : Max. leakage current (μA), C : Nominal capacitance (μF), V : Rated voltage (V)	
Dissipation Factor (tanδ)	Rated voltage (V _{dc})	6.3V 10V 16V 25V 35V 50V
	tanδ	0.22 0.19 0.16 0.14 0.12 0.10
	When nominal capacitance exceeds 1000μF, add 0.02 to the value above for each 1000μF increase. (at 20°C, 120Hz)	
Low Temperature Characteristics	Capacitance changeΔC(-55°C/20°C)	within ±30%
	Max. impedance ratio(-55°C/20°C)	3max. (at 120Hz)
Endurance	The following specifications shall be satisfied when the capacitors are restored to 20°C after subjected to DC voltage with the rated ripple current is applied for the specified period of time at 105°C.	
	Time	φ5 & φ6.3 : 2000hours φ8 & φ10 : 3000hours φ12.5 and larger : 5000hours
	Capacitance change	≤±20% of the initial value
	DF (tanδ)	≤200% of the initial specified value
	Leakage current	≤The initial specified value
Shelf Life	The following specifications shall be satisfied when the capacitors are restored to 20°C after exposing them for 1000 hours at 105°C without voltage applied.	
	Capacitance change	≤±20% of the initial value
	DF (tanδ)	≤200% of the initial specified value
	Leakage current	≤The initial specified value

◆ DIMENSIONS (Radial Lead Type=VB) [mm]

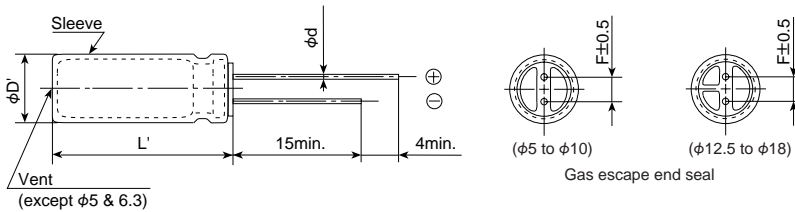

φD	5	6.3	8	10	12.5	16	18
φd	0.5	0.5	0.6	0.6	0.6	0.8	0.8
F	2.0	2.5	3.5	5.0	5.0	7.5	7.5
φD'	φD+0.5max.						
L'	L+1.5max.						

◆ PART NUMBERING SYSTEM

LXJ 16 VB 2200 M K30

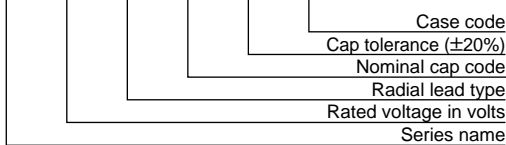

Capacitance	Code
4.7μF	4R7
10μF	10
100μF	100
2200μF	2200

◆STANDARD RATINGS

φDXL (mm)	Items Case code	V _{dc}		6.3			10			16			25				
		Capacitance (μF)	Impedance (Ω _{max} /100kHz)		Rated ripple current (mArms/ 105°C 100kHz)	Capacitance (μF)	Impedance (Ω _{max} /100kHz)		Rated ripple current (mArms/ 105°C 100kHz)	Capacitance (μF)	Impedance (Ω _{max} /100kHz)		Rated ripple current (mArms/ 105°C 100kHz)	Capacitance (μF)	Impedance (Ω _{max} /100kHz)		Rated ripple current (mArms/ 105°C 100kHz)
			20°C	-10°C			20°C	-10°C			20°C	-10°C			20°C	-10°C	
5X11.5	E11	120	1.1	3.3	165	82	1.1	3.3	165	56	1.1	3.3	165	39	1.1	3.3	165
5X15	E15	150	1.0	3.0	180	120	1.0	3.0	180	82	1.0	3.0	180	56	1.0	3.0	180
6.3X11.5	F11	220	0.55	1.6	255	180	0.55	1.6	255	120	0.55	1.6	255	82	0.55	1.6	255
6.3X15	F15	330	0.41	1.2	330	270	0.41	1.2	330	180	0.41	1.2	330	120	0.41	1.2	330
8X12	H12	390	0.29	0.84	415	330	0.29	0.84	415	270	0.29	0.84	415	150	0.29	0.84	415
8X15	H15	560	0.25	0.75	495	470	0.25	0.75	495	330	0.25	0.75	495	220	0.25	0.75	495
8X20	H20	820	0.18	0.52	640	680	0.18	0.52	640	470	0.18	0.52	640	330	0.18	0.52	640
10X12.5	J12	470	0.16	0.40	635	390	0.16	0.40	635	270	0.16	0.40	635	180	0.16	0.40	635
10X16	J16	680	0.12	0.30	795	680	0.12	0.30	795	470	0.12	0.30	795	330	0.12	0.30	795
10X20	J20	1,200	0.088	0.22	1,060	1,000	0.088	0.22	1,060	680	0.088	0.22	1,060	470	0.088	0.22	1,060
10X25	J25	1,500	0.068	0.17	1,240	1,200	0.068	0.17	1,240	820	0.068	0.17	1,240	560	0.068	0.17	1,240
10X30	J30	2,200	0.059	0.15	1,450	1,500	0.059	0.15	1,450	1,200	0.059	0.15	1,450	820	0.059	0.15	1,450
12.5X20	K20	2,200	0.059	0.15	1,360	1,800	0.059	0.15	1,360	1,200	0.059	0.15	1,360	820	0.059	0.15	1,360
12.5X25	K25	2,700	0.045	0.11	1,700	2,200	0.045	0.11	1,700	1,500	0.045	0.11	1,700	1,000	0.045	0.11	1,700
12.5X30	K30	3,900	0.039	0.098	1,980	2,700	0.039	0.098	1,980	2,200	0.039	0.098	1,980	1,500	0.039	0.098	1,980
12.5X35	K35	4,700	0.033	0.083	2,230	3,300	0.033	0.083	2,230	2,700	0.033	0.083	2,230	1,800	0.033	0.083	2,230
12.5X40	K40	5,600	0.029	0.073	2,460	3,900	0.029	0.073	2,460	3,300	0.029	0.073	2,460	2,200	0.029	0.073	2,460
16X20	L20	3,900	0.043	0.11	1,770	3,300	0.043	0.11	1,770	2,200	0.043	0.11	1,770	1,500	0.043	0.11	1,770
16X25	L25	5,600	0.033	0.083	2,190	3,900	0.033	0.083	2,190	2,700	0.033	0.083	2,190	1,800	0.033	0.083	2,190
16X30	L30	6,800	0.029	0.073	2,510	4,700	0.029	0.073	2,510	3,900	0.029	0.073	2,510	2,700	0.029	0.073	2,510
16X35	L35	8,200	0.025	0.063	2,770	6,800	0.025	0.063	2,770	4,700	0.025	0.063	2,770	3,300	0.025	0.063	2,770
16X40	L40	10,000	0.021	0.053	3,110	8,200	0.021	0.053	3,110	5,600	0.021	0.053	3,110	3,900	0.021	0.053	3,110
18X20	M20	5,600	0.039	0.098	1,940	3,900	0.039	0.098	1,940	3,300	0.039	0.098	1,940	2,200	0.039	0.098	1,940
18X25	M25	6,800	0.030	0.075	2,350	4,700	0.030	0.075	2,350	3,900	0.030	0.075	2,350	2,700	0.030	0.075	2,350
18X30	M30	10,000	0.026	0.065	2,720	6,800	0.026	0.065	2,720	4,700	0.026	0.065	2,720	3,300	0.026	0.065	2,720
18X35	M35	12,000	0.023	0.058	3,050	8,200	0.023	0.058	3,050	6,800	0.023	0.058	3,050	3,900	0.023	0.058	3,050
18X40	M40	15,000	0.020	0.050	3,300	10,000	0.020	0.050	3,300	8,200	0.020	0.050	3,300	4,700	0.020	0.050	3,300

φDXL (mm)	Items Case code	V _{dc}		35			50		
		Capacitance (μF)	Impedance (Ω _{max} /100kHz)		Rated ripple current (mArms/ 105°C 100kHz)	Capacitance (μF)	Impedance (Ω _{max} /100kHz)		Rated ripple current (mArms/ 105°C 100kHz)
			20°C	-10°C			20°C	-10°C	
5X11.5	E11	27	1.1	3.3	165	18	1.2	3.6	165
5X15	E15	39	1.0	3.0	180	27	1.0	3.0	170
6.3X11.5	F11	56	0.55	1.6	255	39	0.57	1.7	255
6.3X15	F15	82	0.41	1.2	330	56	0.46	1.4	310
8X12	H12	120	0.29	0.84	415	68	0.29	0.90	415
8X15	H15	180	0.25	0.75	495	82	0.24	0.72	505
8X20	H20	220	0.18	0.52	640	120	0.20	0.58	605
10X12.5	J12	120	0.16	0.40	635	82	0.23	0.58	530
10X16	J16	220	0.12	0.30	795	120	0.17	0.43	675
10X20	J20	330	0.088	0.22	1,060	180	0.13	0.33	860
10X25	J25	390	0.068	0.17	1,240	220	0.096	0.24	1,060
10X30	J30	560	0.059	0.15	1,450	330	0.083	0.21	1,230
12.5X20	K20	560	0.059	0.15	1,360	330	0.083	0.21	1,170
12.5X25	K25	680	0.045	0.11	1,700	470	0.061	0.16	1,500
12.5X30	K30	1,000	0.039	0.098	1,980	560	0.056	0.14	1,680
12.5X35	K35	1,200	0.033	0.083	2,230	680	0.046	0.12	1,900
12.5X40	K40	1,500	0.029	0.073	2,460	820	0.041	0.10	2,120
16X20	L20	1,000	0.043	0.11	1,770	680	0.061	0.16	1,500
16X25	L25	1,200	0.033	0.083	2,190	820	0.046	0.12	1,880
16X30	L30	1,800	0.029	0.073	2,510	1,000	0.041	0.10	2,150
16X35	L35	2,200	0.025	0.063	2,770	1,200	0.037	0.093	2,320
16X40	L40	2,700	0.021	0.053	3,110	1,500	0.030	0.075	2,650
18X20	M20	1,500	0.039	0.098	1,940	820	0.056	0.14	1,660
18X25	M25	1,800	0.030	0.075	2,350	1,000	0.042	0.11	2,020
18X30	M30	2,200	0.026	0.065	2,720	1,500	0.037	0.093	2,340
18X35	M35	2,700	0.023	0.058	3,050	1,800	0.031	0.078	2,620
18X40	M40	3,300	0.020	0.050	3,300	2,200	0.029	0.073	2,790

50V _{dc} φ5X11.50 (E11)			
Capacitance (μF)	Impedance (Ω _{max} /100kHz)		Rated ripple current (mArms/ 105°C 100kHz)
	20°C	-10°C	
0.47	7.0	21.0	65
1.0	5.0	15.0	80
2.2	4.0	12.0	90
3.3	3.5	11.0	95
4.7	3.0	9.0	100
10	2.0	6.0	125

◆RATED RIPPLE CURRENT MULTIPLIERS

●Frequency Multipliers

Rated Voltage (V _{dc})	Case size φD (mm)	Frequency (Hz)			
		120	1k	10k	100k
6.3 to 10	5 to 8	0.65	0.83	0.95	1.00
	10 & 12.5	0.70	0.85	0.96	1.00
	16 & 18	0.85	0.92	0.97	1.00
16 to 25	5 to 8	0.55	0.76	0.91	1.00
	10 & 12.5	0.65	0.83	0.93	1.00
	16 & 18	0.70	0.87	0.96	1.00
35 to 50	5 to 8	0.40	0.66	0.85	1.00
	10 & 12.5	0.50	0.73	0.89	1.00
	16 & 18	0.60	0.81	0.94	1.00
50V _{dc} (0.47 to 3.3μF)		0.20	0.66	0.90	1.00
50V _{dc} (4.7 to 10μF)		0.40	0.76	0.93	1.00

The following case sizes are also available upon request : φ12.5×15mm, φ16×15mm, and φ18×15mm.

New!

KZE Series

- Ultra Low impedance for Personal Computer and Storage Equipment
- Endurance with ripple current: 105°C 2000 to 5000 hours
- Non solvent-proof
- PET sleeve is also available upon requests

KZE

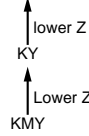

◆ SPECIFICATIONS

Items	Characteristics																				
Category																					
Temperature Range	-40 to +105°C																				
Rated Voltage Range	6.3 to 50V _{dc}																				
Capacitance Tolerance	±20% (M) (at 20°C, 120Hz)																				
Leakage Current	I=0.01CV or 3µA, whichever is greater. Where, I : Max. leakage current (µA), C : Nominal capacitance (µF), V : Rated voltage (V) (at 20°C after 2 minutes)																				
Dissipation Factor (tanδ)	<table border="1"> <tr> <td>Rated voltage (V_{dc})</td> <td>6.3V</td> <td>10V</td> <td>16V</td> <td>25V</td> <td>35V</td> <td>50V</td> </tr> <tr> <td>tanδ (Max.)</td> <td>0.22</td> <td>0.19</td> <td>0.16</td> <td>0.14</td> <td>0.12</td> <td>0.10</td> </tr> </table> <p>When nominal capacitance exceeds 1000µF, add 0.02 to the value above for each 1000µF increase. (at 20°C, 120Hz)</p>	Rated voltage (V _{dc})	6.3V	10V	16V	25V	35V	50V	tanδ (Max.)	0.22	0.19	0.16	0.14	0.12	0.10						
Rated voltage (V _{dc})	6.3V	10V	16V	25V	35V	50V															
tanδ (Max.)	0.22	0.19	0.16	0.14	0.12	0.10															
Low Temperature Characteristics (Max. Impedance Ratio)	<table border="1"> <tr> <td>Z (-25°C) / Z (+20°C)</td> <td>2max.</td> </tr> <tr> <td>Z (-40°C) / Z (+20°C)</td> <td>3max.</td> </tr> </table> <p>(at 120Hz)</p>	Z (-25°C) / Z (+20°C)	2max.	Z (-40°C) / Z (+20°C)	3max.																
Z (-25°C) / Z (+20°C)	2max.																				
Z (-40°C) / Z (+20°C)	3max.																				
Endurance	<p>The following specifications shall be satisfied when the capacitors are restored to 20°C after subjected to DC voltage with the rated ripple current is applied for the specified period of time at 105°C.</p> <table border="1"> <tr> <td>Time</td> <td>φ5 & φ6.3 : 2000hours</td> <td>φ8 : 3000hours</td> <td>φ10 : 4000hours</td> <td>φ12.5 & φ16 : 5000hours</td> </tr> <tr> <td>Capacitance change</td> <td colspan="4">≤±25% of the initial value</td> </tr> <tr> <td>DF (tanδ)</td> <td colspan="4">≤200% of the initial specified value</td> </tr> <tr> <td>Leakage current</td> <td colspan="4">≤The initial specified value</td> </tr> </table>	Time	φ5 & φ6.3 : 2000hours	φ8 : 3000hours	φ10 : 4000hours	φ12.5 & φ16 : 5000hours	Capacitance change	≤±25% of the initial value				DF (tanδ)	≤200% of the initial specified value				Leakage current	≤The initial specified value			
Time	φ5 & φ6.3 : 2000hours	φ8 : 3000hours	φ10 : 4000hours	φ12.5 & φ16 : 5000hours																	
Capacitance change	≤±25% of the initial value																				
DF (tanδ)	≤200% of the initial specified value																				
Leakage current	≤The initial specified value																				
Shelf Life	<p>The following specifications shall be satisfied when the capacitors are restored to 20°C after exposing them for 500 hours at 105°C without voltage applied.</p> <table border="1"> <tr> <td>Capacitance change</td> <td>≤±25% of the initial value</td> </tr> <tr> <td>DF (tanδ)</td> <td>≤200% of the initial specified value</td> </tr> <tr> <td>Leakage current</td> <td>≤The initial specified value</td> </tr> </table>	Capacitance change	≤±25% of the initial value	DF (tanδ)	≤200% of the initial specified value	Leakage current	≤The initial specified value														
Capacitance change	≤±25% of the initial value																				
DF (tanδ)	≤200% of the initial specified value																				
Leakage current	≤The initial specified value																				

◆ DIMENSIONS (Radial Lead Type=VB) [mm]

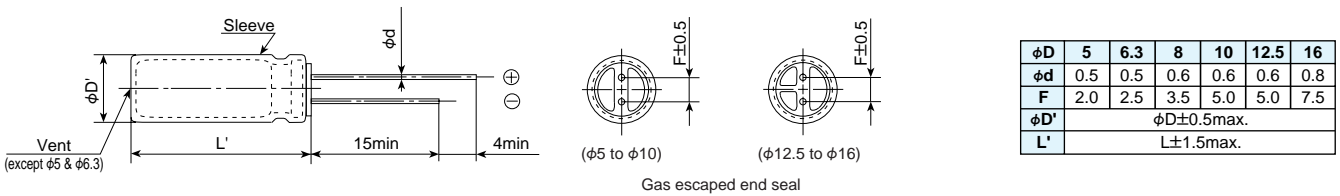

◆ PART NUMBERING SYSTEM

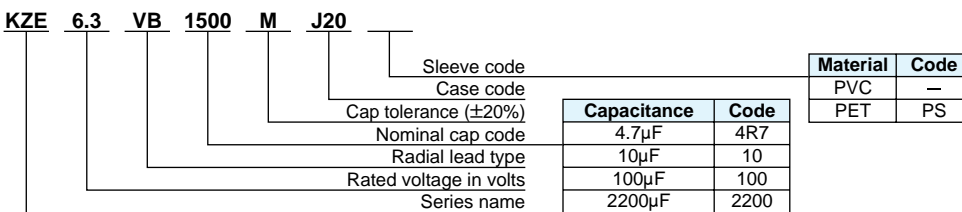

◆STANDARD RATINGS

Case size φDXL(mm)	V _{dc} Case code	6.3				10				16			
		Capacitance (μF)	Impedance (Ωmax/100kHz)		Rated ripple current (mArms/ 105°C 100kHz)	Capacitance (μF)	Impedance (Ωmax/100kHz)		Rated ripple current (mArms/ 105°C 100kHz)	Capacitance (μF)	Impedance (Ωmax/100kHz)		Rated ripple current (mArms/ 105°C 100kHz)
			20°C	-10°C			20°C	-10°C			20°C	-10°C	
5X11	E11	150	0.30	1.0	250	100	0.30	1.0	250	56	0.30	1.0	250
6.3X11	F11	330	0.13	0.41	405	220	0.13	0.41	405	120	0.13	0.41	405
8X11.5	H11	560	0.072	0.22	760	470	0.072	0.22	760	330	0.072	0.22	760
8X15	H15	820	0.056	0.17	995	680	0.056	0.17	995	470	0.056	0.17	995
8X20	H20	1,200	0.041	0.13	1,250	1,000	0.041	0.13	1,250	680	0.041	0.13	1,250
10X12.5	J12	1,000	0.053	0.16	1,030	680	0.053	0.16	1,030	470	0.053	0.16	1,030
10X16	J16	1,200	0.038	0.12	1,430	1,000	0.038	0.12	1,430	680	0.038	0.12	1,430
10X20	J20	1,500	0.023	0.069	1,820	1,200	0.023	0.069	1,820	1,000	0.023	0.069	1,820
10X25	J25	2,200	0.022	0.066	2,150	1,500	0.022	0.066	2,150	1,200	0.022	0.066	2,150
12.5X20	K20	3,300	0.021	0.053	2,360	2,200	0.021	0.053	2,360	1,500	0.021	0.053	2,360
12.5X25	K25	3,900	0.018	0.045	2,770	3,300	0.018	0.045	2,770	2,200	0.018	0.045	2,770
12.5X30	K30	4,700	0.016	0.041	3,290	3,900	0.016	0.041	3,290	2,700	0.016	0.041	3,290
12.5X35	K35	5,600	0.015	0.039	3,400	4,700	0.015	0.039	3,400	3,300	0.015	0.039	3,400
16X20	L20	5,600	0.018	0.045	3,140	3,900	0.018	0.045	3,140	2,700	0.018	0.045	3,140
16X25	L25	6,800	0.016	0.043	3,460	5,600	0.016	0.043	3,460	3,900	0.016	0.043	3,460

Case size φDXL (mm)	V _{dc} Case code	25				35				50			
		Capacitance (μF)	Impedance (Ωmax/100kHz)		Rated ripple current (mArms/ 105°C 100kHz)	Capacitance (μF)	Impedance (Ωmax/100kHz)		Rated ripple current (mArms/ 105°C 100kHz)	Capacitance (μF)	Impedance (Ωmax/100kHz)		Rated ripple current (mArms/ 105°C 100kHz)
			20°C	-10°C			20°C	-10°C			20°C	-10°C	
5X11	E11	47	0.30	1.0	250	33	0.30	1.0	250	22	0.34	1.18	238
6.3X11	F11	100	0.13	0.41	405	56	0.13	0.41	405	56	0.14	0.50	385
8X11.5	H11	220	0.072	0.22	760	150	0.072	0.22	760	100	0.074	0.22	724
8X15	H15	330	0.056	0.17	995	220	0.056	0.17	995	120	0.061	0.18	950
8X20	H20	470	0.041	0.13	1,250	270	0.041	0.13	1,250	180	0.046	0.14	1,190
10X12.5	J12	330	0.053	0.16	1,030	220	0.053	0.16	1,030	150	0.061	0.18	979
10X16	J16	470	0.038	0.12	1,430	330	0.038	0.12	1,430	220	0.042	0.12	1,370
10X20	J20	680	0.023	0.069	1,820	470	0.023	0.069	1,820	270	0.030	0.090	1,580
10X25	J25	820	0.022	0.066	2,150	560	0.022	0.066	2,150	330	0.028	0.085	1,870
12.5X20	K20	1,000	0.021	0.053	2,360	680	0.021	0.053	2,360	470	0.027	0.068	2,050
12.5X25	K25	1,500	0.018	0.045	2,770	1,000	0.018	0.045	2,770	560	0.023	0.059	2,410
12.5X30	K30	1,800	0.016	0.041	3,290	1,200	0.016	0.041	3,290	680	0.021	0.052	2,860
12.5X35	K35	2,200	0.015	0.039	3,400	1,500	0.015	0.039	3,400	820	0.019	0.051	2,960
16X20	L20	1,800	0.018	0.045	3,140	1,200	0.018	0.045	3,140	820	0.023	0.059	2,730
16X25	L25	2,700	0.016	0.043	3,460	1,800	0.016	0.043	3,460	1,000	0.021	0.056	3,010

◆RATED RIPPLE CURRENT MULTIPLIERS

●Frequency Multipliers

Capacitance(μF)	Frequency (Hz)			
	120	1k	10k	100k
22 to 180	0.40	0.75	0.90	1.00
220 to 560	0.50	0.85	0.94	1.00
680 to 1,800	0.60	0.87	0.95	1.00
2,200 to 3,900	0.75	0.90	0.95	1.00
4,700 to	0.85	0.95	0.98	1.00

New!

KY Series

- Newly innovative electrolyte is employed to minimize ESR
- Endurance with ripple current : 3000 to 6000 hours at 105°C
- PET sleeve is also available upon request
- Non solvent-proof type

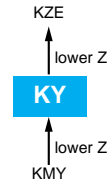

SPECIFICATIONS

Items	Characteristics						
Category Temperature Range	-40 to +105°C						
Rated Voltage Range	6.3 to 50V _{dc}						
Capacitance Tolerance	±20% (M) (at 20°C, 120Hz)						
Leakage Current	I=0.01CV or 3μA, whichever is greater. Where, I : Max. leakage current (μA), C : Nominal capacitance (μF), V : Rated voltage (V) (at 20°C after 2 minutes)						
Dissipation Factor (tanδ)	Rated voltage (V _{dc})	6.3V	10V	16V	25V	35V	50V
	tanδ (Max.)	0.22	0.19	0.16	0.14	0.12	0.10
	When nominal capacitance exceeds 1000μF, add 0.02 to the value above for each 1000μF increase. (at 20°C, 120Hz)						
Low Temperature Characteristics (Max. Impedance Ratio)	Rated voltage (V _{dc})	6.3V	10V	16V	25V	35V	50V
	Z(-25°C)/Z(+20°C)	4	3	2	2	2	2
	Z(-40°C)/Z(+20°C)	8	6	4	3	3	3
Endurance	The following specifications shall be satisfied when the capacitors are restored to 20°C after subjected to DC voltage with the rated ripple current is applied for the specified period of time at 105°C.						
	Time	φ5 & 6.3 : 3000hours φ8 : 4000hours φ10 : 5000hours φ12.5 to 18 : 6000hours					
	Capacitance change	≤±25% of the initial value					
	DF (tanδ)	≤200% of the initial specified value					
	Leakage current	≤The initial specified value					
Shelf Life	The following specifications shall be satisfied when the capacitors are restored to 20°C after exposing them for 500 hours at 105°C without voltage applied.						
	Capacitance change	≤±25% of the initial value					
	DF (tanδ)	≤200% of the initial specified value					
	Leakage current	≤The initial specified value					

DIMENSIONS (Radial Lead Type=VB) [mm]

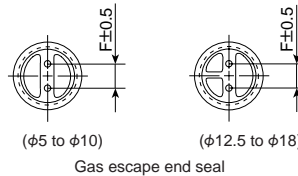
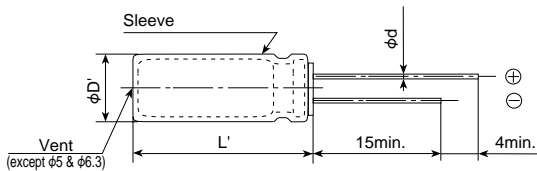

φD	5	6.3	8	10	12.5	16	18
φd	0.5	0.5	0.6	0.6	0.6	0.8	0.8
F	2.0	2.5	3.5	5.0	5.0	7.5	7.5
φD'	φD+0.5max.						
L'	L+1.5max.						

PART NUMBERING SYSTEM

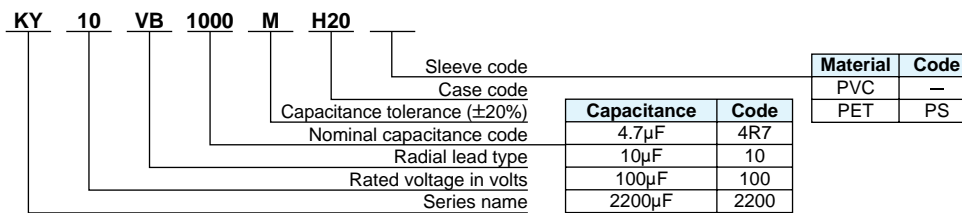

RATED RIPPLE CURRENT MULTIPLIERS

- Frequency Multipliers

Capacitance (μF)	Frequency (Hz)	120	1k	10k	100k
22 to 180		0.40	0.75	0.90	1.00
220 to 560		0.50	0.85	0.94	1.00
680 to 1,800		0.60	0.87	0.95	1.00
2,200 to 3,900		0.75	0.90	0.95	1.00
4,700 to		0.85	0.95	0.98	1.00

◆STANDARD RATINGS

Case size φD×L (mm)	V _{dc} Case code	6.3				10				16			
		Capacitance (μF)	Impedance (Ω _{max} /100kHz)		Rated ripple current (mA _{rms} /105°C 100kHz)	Capacitance (μF)	Impedance (Ω _{max} /100kHz)		Rated ripple current (mA _{rms} /105°C 100kHz)	Capacitance (μF)	Impedance (Ω _{max} /100kHz)		Rated ripple current (mA _{rms} /105°C 100kHz)
			20°C	-10°C			20°C	-10°C			20°C	-10°C	
5×11	E11	150	0.58	2.3	210	100	0.58	2.3	210	56	0.58	2.3	210
6.3×11	F11	330	0.22	0.87	340	220	0.22	0.87	340	120	0.22	0.87	340
8×11.5	H11	680	0.13	0.52	640	470	0.13	0.52	640	330	0.13	0.52	640
8×15	H15	1,000	0.087	0.35	840	680	0.087	0.35	840	470	0.087	0.35	840
8×20	H20	1,200	0.069	0.27	1,050	1,000	0.069	0.27	1,050	680	0.069	0.27	1,050
10×12.5	J12	820	0.080	0.32	865	680	0.080	0.32	865	470	0.080	0.32	865
10×16	J16	1,200	0.060	0.24	1,210	1,000	0.060	0.24	1,210	680	0.060	0.24	1,210
10×20	J20	1,500	0.046	0.18	1,400	1,200	0.046	0.18	1,400	1,000	0.046	0.18	1,400
10×25	J25	2,200	0.042	0.17	1,650	1,500	0.042	0.17	1,650	1,200	0.042	0.17	1,650
10×30	J30	2,700	0.031	0.12	1,910	2,200	0.031	0.12	1,910	1,500	0.031	0.12	1,910
12.5×15	K15	1,800	0.049	0.16	1,450	1,500	0.049	0.16	1,450	1,000	0.049	0.16	1,450
12.5×20	K20	3,300	0.035	0.12	1,900	2,200	0.035	0.12	1,900	1,500	0.035	0.12	1,900
12.5×25	K25	3,900	0.027	0.089	2,230	3,300	0.027	0.089	2,230	2,200	0.027	0.089	2,230
12.5×30	K30	4,700	0.024	0.078	2,650	3,900	0.024	0.078	2,650	2,700	0.024	0.078	2,650
12.5×35	K35	5,600	0.020	0.065	2,880	4,700	0.020	0.065	2,880	3,300	0.020	0.065	2,880
12.5×40	K40	6,800	0.017	0.056	3,350	5,600	0.017	0.056	3,350	3,900	0.017	0.056	3,350
16×15	L15	2,700	0.042	0.12	1,940	2,200	0.042	0.12	1,940	1,500	0.042	0.12	1,940
16×20	L20	5,600	0.027	0.078	2,530	3,900	0.027	0.078	2,530	2,700	0.027	0.078	2,530
16×25	L25	6,800	0.021	0.060	2,930	5,600	0.021	0.060	2,930	3,900	0.021	0.060	2,930
16×31.5	L31	8,200	0.017	0.050	3,450	6,800	0.017	0.050	3,450	4,700	0.017	0.050	3,450
16×35.5	L35	10,000	0.015	0.044	3,610	8,200	0.015	0.044	3,610	5,600	0.015	0.044	3,610
16×40	L40	12,000	0.013	0.038	4,080	10,000	0.013	0.038	4,080	6,800	0.013	0.038	4,080
18×15	M15	3,900	0.043	0.11	2,210	2,700	0.043	0.11	2,210	2,200	0.043	0.11	2,210
18×20	M20	6,800	0.026	0.067	2,860	5,600	0.026	0.067	2,860	3,900	0.026	0.067	2,860
18×25	M25	10,000	0.019	0.049	3,140	6,800	0.019	0.049	3,140	4,700	0.019	0.049	3,140
18×31.5	M31	12,000	0.015	0.040	4,170	8,200	0.015	0.040	4,170	5,600	0.015	0.040	4,170
18×35.5	M35	15,000	0.014	0.038	4,220	10,000	0.014	0.038	4,220	8,200	0.014	0.038	4,220
18×40	M40	18,000	0.012	0.032	4,280	12,000	0.012	0.032	4,280	10,000	0.012	0.032	4,280

Case size φD×L (mm)	V _{dc} Case code	25				35				50			
		Capacitance (μF)	Impedance (Ω _{max} /100kHz)		Rated ripple current (mA _{rms} /105°C 100kHz)	Capacitance (μF)	Impedance (Ω _{max} /100kHz)		Rated ripple current (mA _{rms} /105°C 100kHz)	Capacitance (μF)	Impedance (Ω _{max} /100kHz)		Rated ripple current (mA _{rms} /105°C 100kHz)
			20°C	-10°C			20°C	-10°C			20°C	-10°C	
5×11	E11	47	0.58	2.3	210	33	0.58	2.3	210	22	0.70	2.8	180
6.3×11	F11	100	0.22	0.87	340	56	0.22	0.87	340	56	0.30	1.2	295
8×11.5	H11	220	0.13	0.52	640	150	0.13	0.52	640	100	0.17	0.68	555
8×15	H15	330	0.087	0.35	840	220	0.087	0.35	840	120	0.12	0.48	730
8×20	H20	470	0.069	0.27	1,050	270	0.069	0.27	1,050	180	0.091	0.36	910
10×12.5	J12	330	0.080	0.32	865	220	0.080	0.32	865	150	0.12	0.48	760
10×16	J16	470	0.060	0.24	1,210	330	0.060	0.24	1,210	220	0.084	0.34	1,050
10×20	J20	680	0.046	0.18	1,400	470	0.046	0.18	1,400	270	0.060	0.24	1,220
10×25	J25	820	0.042	0.17	1,650	560	0.042	0.17	1,650	330	0.055	0.22	1,440
10×30	J30	1,000	0.031	0.12	1,910	680	0.031	0.12	1,910	470	0.043	0.17	1,690
12.5×15	K15	680	0.049	0.16	1,450	470	0.049	0.16	1,450	270	0.061	0.20	1,260
12.5×20	K20	1,000	0.035	0.12	1,900	680	0.035	0.12	1,900	470	0.045	0.15	1,660
12.5×25	K25	1,500	0.027	0.089	2,230	1,000	0.027	0.089	2,230	560	0.034	0.11	1,950
12.5×30	K30	1,800	0.024	0.078	2,650	1,200	0.024	0.078	2,650	680	0.030	0.10	2,310
12.5×35	K35	2,200	0.020	0.065	2,880	1,500	0.020	0.065	2,880	820	0.025	0.083	2,510
12.5×40	K40	2,700	0.017	0.056	3,350	1,800	0.017	0.056	3,350	1,000	0.021	0.069	2,920
16×15	L15	1,000	0.042	0.12	1,940	680	0.042	0.12	1,940	470	0.055	0.17	1,690
16×20	L20	1,800	0.027	0.078	2,530	1,200	0.027	0.078	2,530	820	0.034	0.10	2,210
16×25	L25	2,700	0.021	0.060	2,930	1,800	0.021	0.060	2,930	1,000	0.025	0.075	2,555
16×31.5	L31	3,300	0.017	0.050	3,450	2,200	0.017	0.050	3,450	1,200	0.022	0.066	3,010
16×35.5	L35	3,900	0.015	0.044	3,610	2,700	0.015	0.044	3,610	1,500	0.019	0.057	3,150
16×40	L40	4,700	0.013	0.038	4,080	3,300	0.013	0.038	4,080	1,800	0.016	0.048	3,710
18×15	M15	1,200	0.043	0.11	2,210	1,000	0.043	0.11	2,210	560	0.054	0.15	1,930
18×20	M20	2,200	0.026	0.067	2,860	1,800	0.026	0.067	2,860	1,000	0.036	0.097	2,490
18×25	M25	3,300	0.019	0.049	3,140	2,200	0.019	0.049	3,140	1,200	0.026	0.070	2,740
18×31.5	M31	3,900	0.015	0.040	4,170	2,700	0.015	0.040	4,170	1,800	0.021	0.057	3,635
18×35.5	M35	4,700	0.014	0.038	4,220	3,300	0.014	0.038	4,220	2,200	0.017	0.046	3,680
18×40	M40	5,600	0.012	0.032	4,280	3,900	0.012	0.032	4,280	2,700	0.014	0.038	3,800

KMF Series

- Endurance with ripple current: 105°C 2000 to 5000 hours
- Solvent-proof (6.3 to 100V_{dc}), see page 16



↑ lower Z
longer life
KME



◆SPECIFICATIONS

Items	Characteristics														
Category	-55 to +105°C(6.3 to 100V _{dc}) -40 to +105°C(160 to 400V _{dc}) -25 to +105°C(450V _{dc})														
Temperature Range															
Rated Voltage Range	6.3 to 450V _{dc}														
Capacitance Tolerance	±20% (M) (at 20°C, 120Hz)														
Leakage Current	6.3 to 100V _{dc}						160 to 450V _{dc}								
	I=0.03CV or 4μA, whichever is greater. (at 20°C after 1 minute)						CV < 1000			After 1 minute			After 5 minutes		
	I=0.01CV or 3μA, whichever is greater. (at 20°C after 2 minutes)						CV ≤ 1000			I=0.1CV+40			I=0.03CV+15		
							CV > 1000			I=0.04CV+100			I=0.02CV+25		
Where, I : Max. leakage current (μA), C : Nominal capacitance (μF), V : Rated voltage (V) (at 20°C)															
Dissipation Factor (tanδ)	Rated voltage (V _{dc})	6.3V	10V	16V	25V	35V	50V	63V	100V	160 to 250V	400V	450V			
	tanδ (Max.)	0.22	0.19	0.16	0.14	0.12	0.10	0.09	0.08	0.20	0.24	0.24			
	When nominal capacitance exceeds 1000μF, add 0.02 to the value above for each 1000μF increase. (at 20°C, 120Hz)														
Low Temperature Characteristics (Max. Impedance Ratio)	Rated voltage (V _{dc})	6.3V	10V	16V	25V	35V	50V	63V	100V	160 to 250V	400V	450V			
	Z(-25°C)/Z(+20°C)	4	3	2	2	2	2	2	2	3	5	6			
	Z(-40°C)/Z(+20°C)	8	6	4	3	3	3	3	3	6	6	-			
(at 120Hz)															
Endurance	The following specifications shall be satisfied when the capacitors are restored to 20°C after subjected to DC voltage with the rated ripple current is applied for the specified period of time at 105°C.														
	Time for 6.3 to 100V _{dc}	φ5 & 6.3 : 2000 hours φ8 & 10 : 3000 hours φ12.5 and larger : 5000 hours													
	Time for 160 to 450V _{dc}	2000 hours													
	Capacitance change	≤±20% of the initial value													
	DF (tanδ)	≤200% of the initial specified value													
Leakage current	≤The initial specified value														
Shelf Life	The following specifications shall be satisfied when the capacitors are restored to 20°C after exposing them for 1000 hours at 105°C without voltage applied.														
	Rated voltage	6.3 to 100V _{dc}						160 to 450V _{dc}							
	Capacitance change	≤±20% of the initial value						≤±20% of the initial value							
	DF (tanδ)	≤200% of the initial specified value						≤200% of the initial specified value							
	Leakage current	≤The initial specified value						≤500% of the initial specified value							

◆DIMENSIONS (Radial Lead Type=VB) [mm]

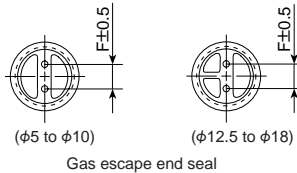
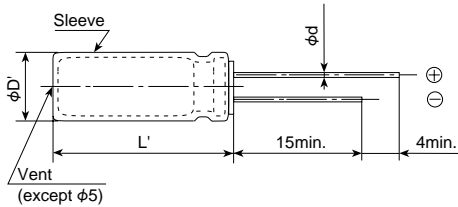

φD	5	6.3	8	10	12.5	16	18
φd	0.5	0.5	0.6	0.6	0.6	0.8	0.8
F	2.0	2.5	3.5	5.0	5.0	7.5	7.5
φD'	φD+0.5max.						
L'	L+1.5max.						

◆PART NUMBERING SYSTEM

KMF 6.3 VB 1000 M

Cap tolerance (±20%)
Nominal cap code
Radial lead type
Rated voltage in volts
Series name

Capacitance	Code
0.47μF	R47
4.7μF	4R7
10μF	10
100μF	100
470μF	470

◆RATED RIPPLE CURRENT MULTIPLIERS

- Frequency Multipliers

Rated Voltage(V _{dc})	Case code	Frequency(Hz)			
		120	1k	10k	100k
6.3 10	φ5 (to 47μF)	0.40	0.75	0.93	1.00
	φ5 (100μF), φ6.3, φ8	0.70	0.86	0.96	1.00
	φ10 to φ18	0.85	0.95	0.98	1.00
16 to 35	φ5 (to 22μF)	0.30	0.68	0.91	1.00
	φ5 (33μF to), φ6.3, φ8	0.50	0.80	0.94	1.00
	φ10 to φ18	0.70	0.88	0.97	1.00
50 63	φ5 (to 3.3μF)	0.20	0.66	0.90	1.00
	φ5 (4.7μF to), φ6.3, φ8	0.40	0.76	0.93	1.00
	φ10 to φ18	0.60	0.84	0.96	1.00
100	φ5 (to 1μF)	0.20	0.60	0.88	1.00
	φ5 (2.2μF to), φ6.3, φ8	0.30	0.65	0.90	1.00
	φ10 to φ18	0.40	0.75	0.93	1.00
160 to 450	φ10	0.25	0.61	0.88	1.00
	φ12.5 to φ18	0.35	0.66	0.89	1.00

◆STANDARD RATINGS

Cap (μF) Items	V _{dc}	6.3			10			16			25						
		Case size	Impedance	Rated ripple	Case size	Impedance	Rated ripple	Case size	Impedance	Rated ripple	Case size	Impedance	Rated ripple				
4.7											5X11	3.0	9.0	100			
10																	
22					5X11	1.3	3.9	154	5X11	1.3	3.9	154	5X11	2.0	6.0	124	
33		5X11	1.3	3.9	154	5X11	1.3	3.9	154	5X11	1.3	3.9	154	5X11	1.3	3.9	154
47		5X11	1.3	3.9	154	5X11	1.3	3.9	154	5X11	1.3	3.9	154	5X11	1.3	3.9	154
100		5X11	1.3	3.9	154	5X11	1.3	3.9	154	6.3X11	0.60	1.8	260	6.3X11	0.60	1.8	260
220		6.3X11	0.60	1.8	260	6.3X11	0.60	1.8	260	8X11.5	0.33	0.99	400	8X11.5	0.33	0.99	400
330		6.3X11	0.60	1.8	260	8X11.5	0.33	0.99	400	8X11.5	0.33	0.99	400	10X12.5	0.25	0.75	510
470		8X11.5	0.33	0.99	400	8X11.5	0.33	0.99	400	10X12.5	0.25	0.75	510	10X16	0.19	0.57	635
1,000		10X12.5	0.25	0.75	510	10X16	0.19	0.57	635	10X20	0.14	0.42	860	12.5X20	0.085	0.26	1,120
2,200		12.5X20	0.085	0.26	1,120	12.5X20	0.085	0.26	1,120	12.5X25	0.070	0.21	1,320	16X25	0.060	0.18	1,570
3,300		12.5X20	0.085	0.26	1,120	12.5X25	0.070	0.21	1,320	16X25	0.060	0.18	1,570	16X31.5	0.048	0.14	1,810
4,700		16X25	0.060	0.18	1,570	16X25	0.060	0.18	1,570	16X31.5	0.048	0.14	1,810	18X35.5	0.037	0.11	2,240
6,800		16X25	0.060	0.18	1,570	16X31.5	0.048	0.14	1,810	18X35.5	0.037	0.11	2,240	18X40	0.034	0.10	2,460
10,000		16X31.5	0.048	0.14	1,810	18X35.5	0.037	0.11	2,240	18X40	0.034	0.10	2,460				
15,000		18X35.5	0.037	0.11	2,240												

Cap (μF) Items	V _{dc}	35			50			63			100						
		Case size	Impedance	Rated ripple	Case size	Impedance	Rated ripple	Case size	Impedance	Rated ripple	Case size	Impedance	Rated ripple				
0.47					5X11	7.0	21.0	66				5X11	10.0	35.0	55		
1.0					5X11	5.0	15.0	78				5X11	7.0	25.0	66		
2.2					5X11	4.0	12.0	88				5X11	6.0	21.0	72		
3.3					5X11	3.5	11.0	94				5X11	5.0	18.0	78		
4.7		5X11	3.0	9.0	100	5X11	3.0	9.0	100	5X11	4.0	14.0	88	5X11	4.0	14.0	88
10		5X11	2.0	6.0	124	5X11	2.0	6.0	124	5X11	2.5	8.8	124	6.3X11	1.2	4.2	180
22		5X11	1.3	3.9	154	5X11	1.3	3.9	154	6.3X11	1.2	4.2	180	8X11.5	0.66	2.3	282
33		5X11	1.3	3.9	154	6.3X11	0.60	1.8	260	6.3X11	1.2	4.2	180	10X12.5	0.50	1.8	380
47		6.3X11	0.60	1.8	260	6.3X11	0.60	1.8	260	8X11.5	0.56	2.0	305	10X16	0.32	1.1	500
100		8X11.5	0.33	0.99	400	8X11.5	0.33	0.99	400	10X12.5	0.50	1.8	380	12.5X20	0.16	0.56	890
220		10X12.5	0.25	0.75	510	10X16	0.19	0.57	635	10X20	0.27	0.95	620	16X25	0.090	0.32	1,440
330		10X16	0.19	0.57	635	10X20	0.14	0.42	860	12.5X20	0.16	0.56	890	16X25	0.090	0.32	1,440
470		10X20	0.14	0.42	860	12.5X20	0.085	0.26	1,120	12.5X25	0.14	0.49	1,040	16X31.5	0.060	0.21	1,790
1,000		12.5X25	0.070	0.21	1,320	16X25	0.060	0.18	1,570	16X31.5	0.060	0.21	1,790				
2,200		16X31.5	0.048	0.14	1,810	18X35.5	0.037	0.11	2,240								
3,300		18X35.5	0.037	0.11	2,240												
4,700		18X40	0.034	0.10	2,460												
6,800																	

(mArms/105°C, 100kHz)
 (Ω_{max}/-10°C, 100kHz)
 (Ω_{max}/20°C, 100kHz)
 φD×L (mm)

Non solvent-proof										
Cap (μF) Items	V _{dc}	160			200			250		
		Case size	Impedance	Rated ripple	Case size	Impedance	Rated ripple	Case size	Impedance	Rated ripple
4.7								10X16	3.5	165
10		10X16	1.5	250	10X16	1.5	250	10X20	2.8	230
22		10X20	1.1	350	10X20	1.1	350	12.5X25	1.2	360
33		12.5X20	0.71	440	12.5X20	0.71	440	12.5X25	1.2	360
47		12.5X25	0.46	600	12.5X25	0.46	600	16X25	0.60	570
100		16X25	0.24	910	16X31.5	0.17	1,160	18X35.5	0.30	935
220		18X35.5	0.14	1,370	18X35.5	0.14	1,370	18X40	0.27	1,000

Non solvent-proof							
Cap (μF) Items	V _{dc}	400			450		
		Case size	Impedance	Rated ripple	Case size	Impedance	Rated ripple
2.2					10X16	7.9	110
3.3		10X20	2.9	195	10X20	6.2	135
4.7		10X25	2.3	220	12.5X20	3.7	190
10		12.5X25	1.2	360	12.5X25	2.6	250
22		16X25	0.61	570	16X31.5	1.0	480
33		16X31.5	0.46	700	18X35.5	0.62	650
47		18X31.5	0.33	860			

(mArms/105°C, 100kHz)
 (Ω_{max}/20°C, 100kHz)
 φD×L (mm)

KMX Series

- Slender case sizes are lined up for laying down small places on PC board
- For electronic ballast circuits and other long life required applications
- Endurance with ripple current : 105°C 8000 to 10000 hours
- Non solvent-proof type



◆ SPECIFICATIONS

Items	Characteristics			
Category	—40 to +105°C (160 to 400V _{dc}) —25 to +105°C (450V _{dc})			
Temperature Range				
Rated Voltage Range	160 to 450V _{dc}			
Capacitance Tolerance	±20% (M) (at 20°C, 120Hz)			
Leakage Current	CV	time	After 1 minute	After 5 minutes
	CV ≤ 1000		I = 0.1CV + 40	I = 0.03CV + 15
	CV > 1000		I = 0.04CV + 100	I = 0.02CV + 25
	Where, I : Max. leakage current (μA), C : Nominal capacitance (μF), V : Rated voltage (V) (at 20°C)			
Dissipation Factor (tanδ)	Rated voltage (V _{dc})	160 to 250V	350 & 400V	450V
	tanδ (Max.)	0.20	0.24	0.24
Low Temperature Characteristics (Max. Impedance Ratio)	Rated voltage (V _{dc})	160 to 250V	350 & 400V	450V
	Z(-25°C)/Z(+20°C)	3	5	6
	Z(-40°C)/Z(+20°C)	6	6	—
Endurance	The following specifications shall be satisfied when the capacitors are restored to 20°C after subjected to DC voltage with the rated ripple current is applied for 10000 hours (8000 hours for φ10) at 105°C.			
	Capacitance change	≤ ±20% of the initial value		
	DF (tanδ)	≤ 200% of the initial specified value		
	Leakage current	≤ The initial specified value		
Shelf Life	The following specifications shall be satisfied when the capacitors are restored to 20°C after exposing them for 1000 hours at 105°C without voltage applied.			
	Capacitance change	≤ ±20% of the initial value		
	DF (tanδ)	≤ 200% of the initial specified value		
	Leakage current	≤ 500% of the initial specified value		

◆ DIMENSIONS (Radial Lead Type=VB) [mm]

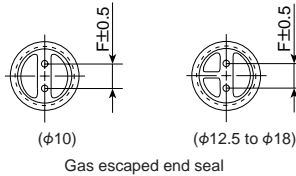
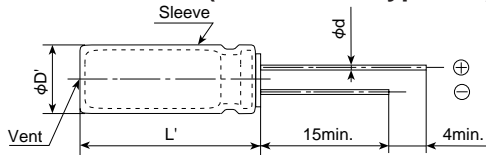

φD	10	12.5	16	18
φd	0.6	0.6	0.8	0.8
F	5.0	5.0	7.5	7.5
φD'	φD+0.5max.			
L'	L+1.5max.			

◆ PART NUMBERING SYSTEM

KMX 400 VB 33 M L20

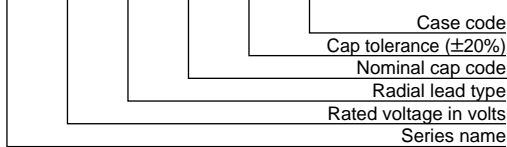

Capacitance	Code
4.7μF	4R7
10μF	10
100μF	100
220μF	220

◆STANDARD RATINGS

V _{dc} Cap (μF)	Items	160					200				
		Case size φDXL (mm)	Case code	Impedance (Ω _{max./} 20°C, 100kHz)	Rated ripple current (mArms/105°C)		Case size φDXL (mm)	Case code	Impedance (Ω _{max./} 20°C, 100kHz)	Rated ripple current (mArms/105°C)	
					120Hz	100kHz				120Hz	100kHz
22						10×20	J20	1.5	165	440	
33		10×20	J20	1.3	210	565	12.5×20	K20	0.91	230	590
47		12.5×20	K20	0.91	270	725	12.5×20	K20	0.91	270	780
68		12.5×25	K25	0.63	350	950	12.5×25	K25	0.63	350	950
		16×20	L20	0.47	430	970	16×20	L20	0.47	430	970
100		10×50	J50	0.27	475	1,280	10×50	J50	0.73	430	930
		16×20	M20	0.31	465	1,180	16×25	L25	0.27	425	1,280
		18×20	M20	0.31	465	1,180	18×20	M20	0.31	465	1,180
150		10×50	J50	0.77	545	1,020	12.5×40	K40	0.56	615	1,200
		16×31.5	L31	0.22	625	1,300	16×25	L25	0.27	580	1,300
		18×25	M25	0.23	600	1,300					
220		12.5×45	K45	0.52	740	1,200	12.5×55	K55	0.39	790	1,420
		16×31.5	L31	0.22	750	1,300					
		18×25	M25	0.23	725	1,300	18×31.5	M31	0.22	780	1,700
330		16×40	L40	0.35	990	1,540	16×50	L50	0.28	1,020	1,870
		18×31.5	M31	0.22	960	1,700					
470		16×55	L55	0.25	1,220	1,870	18×50	M50	0.23	1,230	2,180
560		16×60	L60	0.23	1,350	2,140	18×60	M60	0.18	1,330	2,390
680		18×55	M55	0.20	1,480	2,330					

V _{dc} Cap (μF)	Items	250					350				
		Case size φDXL (mm)	Case code	Impedance (Ω _{max./} 20°C, 100kHz)	Rated ripple current (mArms/105°C)		Case size φDXL (mm)	Case code	Impedance (Ω _{max./} 20°C, 100kHz)	Rated ripple current (mArms/105°C)	
					120Hz	100kHz				120Hz	100kHz
10		10×20	J20	3.5	110	300	Use KMX400VB10MJ20				
22		12.5×20	K20	2.3	185	480	12.5×20	K20	2.1	185	270
33		12.5×25	K25	1.7	250	630	16×20	L20	0.91	250	600
47		12.5×25	K25	1.7	295	630	10×50	J50	1.2	270	705
		16×20	L20	1.1	300	750	16×25	L25	0.73	325	700
68		18×20	M20	0.90	385	900	18×20	M20	0.75	350	750
		10×50	J50	0.73	340	840	12.5×40	K40	1.1	335	895
		16×25	L25	0.78	390	1,000	16×31.5	L31	0.49	420	1,100
100		18×20	M20	0.90	385	900	18×25	M25	0.53	400	875
		12.5×40	K40	0.56	500	1,200	12.5×55	K55	0.71	435	1,050
		16×31.5	L31	0.63	520	1,400					
150		18×25	M25	0.63	500	1,345	18×31.5	M31	0.40	530	1,170
		12.5×55	K55	0.39	650	1,420					
		18×31.5	M31	0.42	640	1,450	16×50	L50	0.51	690	1,400
220		16×50	L50	0.28	820	1,710					
		18×40	M40	0.35	820	1,485	18×55	M55	0.32	840	1,610
330		18×50	M50	0.23	1,030	2,140					

V _{dc} Cap (μF)	Items	400					450				
		Case size φDXL (mm)	Case code	Impedance (Ω _{max./} 20°C, 100kHz)	Rated ripple current (mArms/105°C)		Case size φDXL (mm)	Case code	Impedance (Ω _{max./} 20°C, 100kHz)	Rated ripple current (mArms/105°C)	
					120Hz	100kHz				120Hz	100kHz
3.3						10×20	J20	6.5	60	150	
4.7						12.5×20	K20	3.6	80	200	
10		10×20	J20	2.9	110	180	12.5×25	K25	2.5	125	315
22		10×45	J45	2.3	200	300	10×45	J45	2.3	185	520
		12.5×25	K25	1.3	200	600	16×25	L25	1.7	210	570
		16×20	L20	0.91	200	600	18×20	M20	2.1	200	550
33		10×40	J40	1.7	215	640	12.5×40	K40	1.3	235	710
		16×20	L20	0.91	250	600	16×31.5	L31	1.1	275	620
							18×25	M25	1.1	280	590
47		12.5×40	K40	1.1	280	775	12.5×50	K50	0.95	300	845
		16×25	L25	0.73	325	700					
		18×20	M20	0.75	350	750	18×31.5	M31	0.93	340	900
68		12.5×50	K50	0.81	335	895					
		16×31.5	L31	0.49	420	1,100	16×40	L40	0.71	445	985
		18×25	M25	0.53	400	875	18×35.5	M35	0.71	420	980
100		16×40	L40	0.63	540	1,210	16×60	L60	0.45	570	1,300
		18×35.5	M35	0.34	545	1,250					
150		16×60	L60	0.41	695	1,490	18×60	M60	0.41	690	1,510

SMH Series

- Downsized from current standard SMG series
- Endurance with ripple current : 85°C 2000 hours
- For input filtering of power supplies
- Non solvent-proof

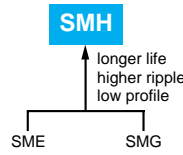

◆ SPECIFICATIONS

Items	Characteristics		
Category	-25 to +85°C		
Temperature Range	-25 to +85°C		
Rated Voltage Range	160 to 450V _{dc}		
Capacitance Tolerance	±20% (M) (at 20°C, 120Hz)		
Leakage Current	I = 0.03CV or 3 mA, whichever is smaller. Where, I : Max. leakage current (μA), C : Nominal capacitance (μF), V : Rated voltage (V) (at 20°C after 5 minutes)		
Dissipation Factor (tanδ)	0.15max. (at 20°C, 120Hz)		
Low Temperature Characteristics (Max. Impedance Ratio)	Rated voltage (V _{dc})	160 to 250V	400 & 450V
	Z(-25°C)/Z(+20°C)	4	6
	(at 120Hz)		
Endurance	The following specifications shall be satisfied when the capacitors are restored to 20°C after subjected to DC voltage with the rated ripple current is applied for 2000 hours at 85°C.		
	Capacitance change	≤±20% of the initial value	
	DF (tanδ)	≤200% of the initial specified value	
	Leakage current	≤The initial specified value	
Shelf Life	The following specifications shall be satisfied when the capacitors are restored to 20°C after exposing them for 1000 hours at 85°C without voltage applied.		
	Capacitance change	≤±20% of the initial value	
	DF (tanδ)	≤200% of the initial specified value	
	Leakage current	≤500% of the initial specified value	

◆ DIMENSIONS (Radial Lead Type=VB) [mm]

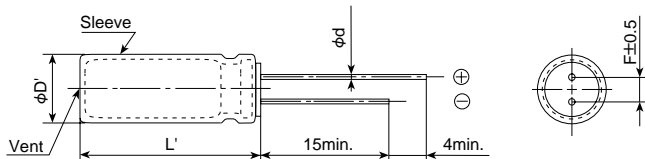

φD	20	22
φd	1.0	
F	10.0	
φD'	φD+0.5max.	
L'	L+2.0max.	

*Note : The snap-in forming type, RC-type, is available upon request, RC-type fits two φ2mm holes and 10mm spacing. See page 23.

◆ PART NUMBERING SYSTEM

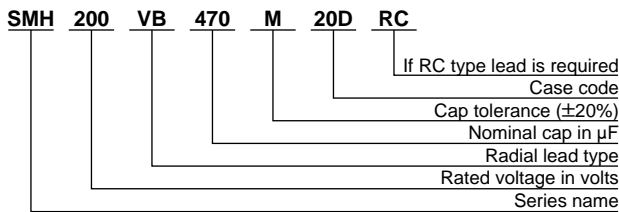

◆ CASE CODE [mm]

Case code	Case size φD×L	Case code	Case size φD×L
20S	20×20	22S	22×20
20A	20×25	22A	22×25
20B	20×30	22B	22×30
20C	20×35	22C	22×35
20D	20×40	22D	22×40
20E	20×45	22E	22×45
20F	20×50	22F	22×50

◆ RATED RIPPLE CURRENT MULTIPLIERS

- Frequency Multipliers

Frequency (Hz)	50	120	300	1k	10k	50k
160 to 250V _{dc}	0.81	1.00	1.17	1.32	1.45	1.50
400 & 450V _{dc}	0.77	1.00	1.16	1.30	1.41	1.43



SMH Series

◆STANDARD RATINGS

μF	V _{dc}		160		200		250		400		450	
	φD		20	22	20	22	20	22	20	22	20	22
33											20×20 0.40	
47									20×20 0.48		20×25 0.52	22×25 0.57
56									20×25 0.57	22×25 0.62	20×30 0.62	22×25 0.65
68									20×25 0.64	22×25 0.69	20×35 0.72	22×30 0.69
82									20×30 0.75	22×25 0.78	20×35 0.79	22×30 0.80
100							20×20 0.67		20×35 0.87	22×30 0.90	20×40 0.92	22×35 0.94
120							20×25 0.85	22×20 0.83	20×40 1.02	22×35 1.03	20×45 1.07	22×40 1.11
150			20×20 0.82	22×20 0.87	20×25 0.94	22×25 1.03	20×45 1.20	22×40 1.24	20×50 1.24	22×45 1.29		
180	20×20 0.90	22×20 0.95	20×25 0.97	22×25 1.05	20×30 1.12	22×25 1.12	20×50 1.36	22×45 1.41			22×50 1.44	
220	20×25 1.07	22×25 1.16	20×25 1.07	22×25 1.16	20×30 1.24	22×30 1.33		22×50 1.59				
270	20×30 1.29	22×25 1.29	20×30 1.29	22×30 1.39	20×35 1.44	22×30 1.47						
330	20×30 1.43	22×30 1.53	20×35 1.49	22×30 1.53	20×40 1.70	22×35 1.71						
390	20×30 1.55	22×30 1.67	20×35 1.62	22×30 1.67	20×45 1.93	22×40 2.00	← Upper : Case size φD×L (mm) ← Lower : Rated ripple current (Arms) at 85°C, 120Hz					
470	20×35 1.78	22×30 1.83	20×40 1.90	22×35 1.92	20×50 2.19	22×45 2.29						

KMH Series

- Radial lead type ranging from φ20×20 to φ22×50mm
- For input filtering of power supplies
- Endurance with ripple current : 105°C 2000 hours
- Non solvent-proof

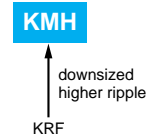

◆ SPECIFICATIONS

Items	Characteristics		
Category	-25 to +105°C		
Temperature Range			
Rated Voltage Range	160 to 450V _{dc}		
Capacitance Tolerance	±20% (M) (at 20°C, 120Hz)		
Leakage Current	I = 0.03CV or 3 mA, whichever is smaller. Where, I : Max. leakage current (µA), C : Nominal capacitance (µF), V : Rated voltage (V) (at 20°C after 5 minutes)		
Dissipation Factor (tanδ)	0.15max. (at 20°C, 120Hz)		
Low Temperature Characteristics (Max. Impedance Ratio)	Rated voltage (V _{dc})	160 to 250V	400 & 450V
	Z(-25°C)/Z(+20°C)	4	6
	(at 120Hz)		
Endurance	The following specifications shall be satisfied when the capacitors are restored to 20°C after subjected to DC voltage with the rated ripple current is applied for 2000 hours at 105°C.		
	Capacitance change	≤±20% of the initial value	
	DF (tanδ)	≤200% of the initial specified value	
	Leakage current	≤The initial specified value	
Shelf Life	The following specifications shall be satisfied when the capacitors are restored to 20°C after exposing them for 1000 hours at 105°C without voltage applied.		
	Capacitance change	≤±20% of the initial value	
	DF (tanδ)	≤200% of the initial specified value	
	Leakage current	≤500% of the initial specified value	

◆ DIMENSIONS (Radial Lead Type=VB) [mm]

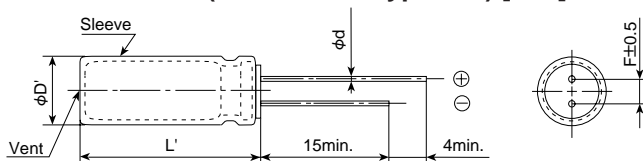

φD	20	22
φd	1.0	
F	10.0	
φD'	φD+0.5max.	
L'	L+2.0max.	

*Note : The snap-in forming type, RC-type, is available upon request, RC-type fits two φ2mm holes and 10mm spacing. See page 23.

◆ PART NUMBERING SYSTEM

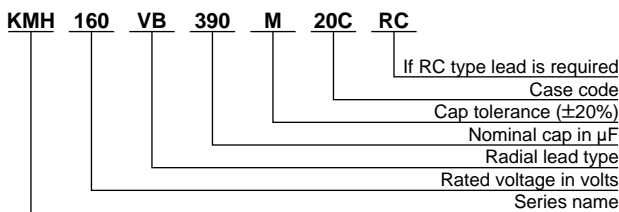

◆ CASE CODE [mm]

Case code	Case size φDXL	Case code	Case size φDXL
20S	20×20	22S	22×20
20A	20×25	22A	22×25
20B	20×30	22B	22×30
20C	20×35	22C	22×35
20D	20×40	22D	22×40
20E	20×45	22E	22×45
20F	20×50	22F	22×50

◆ RATED RIPPLE CURRENT MULTIPLIERS

- Frequency Multipliers

Frequency (Hz)	50	120	300	1k	10k	50k
160 to 250V _{dc}	0.81	1.00	1.17	1.32	1.45	1.50
400 & 450V _{dc}	0.77	1.00	1.16	1.30	1.41	1.43



◆STANDARD RATINGS

μF	V _{dc} φD	160		200		250		400		450	
		20	22	20	22	20	22	20	22	20	22
33								20×20 0.29		20×25 0.31	
47									22×20 0.37		22×25 0.42
56								20×25 0.41		20×30 0.44	
68								20×30 0.49	22×25 0.51	20×35 0.51	22×30 0.52
82						20×20 0.46				20×40 0.60	22×35 0.60
100								20×35 0.62	22×30 0.64	20×45 0.69	22×40 0.71
120				20×20 0.52		20×25 0.60	22×20 0.59	20×40 0.72	22×35 0.73	20×50 0.78	22×45 0.81
150		20×20 0.58		20×25 0.63	22×20 0.62			20×45 0.85	22×40 0.88		22×50 0.93
180		20×25 0.69	22×20 0.68	20×25 0.69	22×25 0.75	20×30 0.79	22×25 0.79	20×50 0.96	22×45 0.99		
220		20×25 0.76	22×25 0.82	20×30 0.82	22×25 0.82	20×35 0.92	22×30 0.95		22×50 1.13		
270		20×30 0.91	22×25 0.91	20×30 0.91	22×30 0.98	20×40 1.09	22×35 1.14				
330		20×30 1.01	22×30 1.16	20×35 1.05	22×35 1.20	20×45 1.26	22×40 1.30				
390		20×35 1.15	22×30 1.27	20×40 1.22	22×35 1.31	20×50 1.41	22×45 1.49	← Upper : Case size φDXL (mm) ← Lower : Rated ripple current (Arms) at 105°C, 120Hz			
470		20×40 1.34	22×35 1.40	20×45 1.34	22×40 1.45		22×50 1.65				

PA Series

- Endurance with ripple current : 105°C 2,000 hours
- Higher ripple current than KMG, general purpose series
- KMG equivalent or even lower profile case sizes
- Suitable for low profile equipment such as AC adaptors

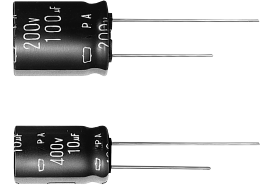

◆SPECIFICATIONS

Items	Characteristics	
Category Temperature Range	-40 to 105°C	
Rated Voltage Range	200 & 400V _{dc}	
Capacitance Tolerance	±20%(M) (at 20°C, 120Hz)	
Leakage Current	I=0.04CV+100(after 1 minute at 20°C) I=0.02CV+25(after 5 minutes at 20°C) Where: I : Max. leakage current(µA), C : Nominal capacitance(µF), V : Rated voltage(V)	
Dissipation factor (tanδ)	Rated voltage(V _{dc})	200 400
	tanδ(Max.)	0.20 0.24 (at 20°C, 120Hz)
Low Temperature Characteristics	Rated voltage(V _{dc})	200 400
	Z(-25°C)/Z(20°C)	3 5
	Z(-40°C)/Z(20°C)	6 6 (at 20°C, 120Hz)
Endurance	The following specifications shall be satisfied when the capacitors are restored to 20°C after subjected to the rated voltage with the rated ripple current is applied for 2,000 hours at 105°C.	
	Capacitance change	≤±20% of the initial value
	DF(tanδ)	≤200% of the initial specified value
	Leakage current	≤The initial specified value
Shelf Life	The following specifications shall be satisfied when the capacitors are restored to 20°C after exposing them for 1,000 hours at 105°C without voltage applied.	
	Capacitance change	≤±20% of the initial value
	DF(tanδ)	≤200% of the initial specified value
	Leakage current	≤500% of the initial specified value

◆DIMENSIONS (Radial Lead Type=VB) [mm]

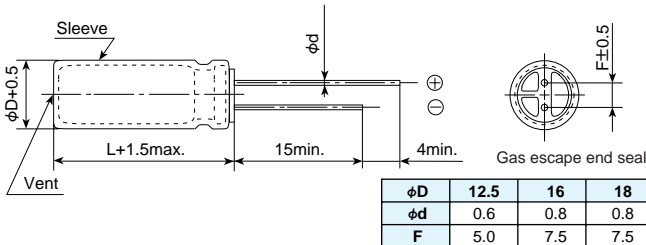

◆PART NUMBERING SYSTEM

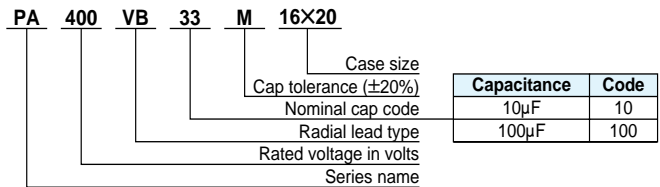

◆STANDARD RATINGS

Nominal capacitance (µF)	200V _{dc}			Rated ripple current (mArms) at 105°C, 120Hz
	Case size φD×L (mm)	Part number		
33	12.5×20	PA200VB33M12.5×20		203
47	12.5×20	PA200VB47M12.5×20		242
56	12.5×25	PA200VB56M12.5×25		288
68	12.5×25	PA200VB68M12.5×25		317
	16×20	PA200VB68RM16×20		323
82	16×20	PA200VB82M16×20		355
100	16×20	PA200VB100M16×20		392
120	16×25	PA200VB120M16×25		465
	18×20	PA200VB120M18×20		446
150	18×25	PA200VB150M18×25		536

Nominal capacitance (µF)	400V _{dc}			Rated ripple current (mArms) at 105°C, 120Hz
	Case size φD×L (mm)	Part number		
10	12.5×20	PA400VB10M12.5×20		110
22	12.5×25	PA400VB22M12.5×25		180
	16×20	PA400VB22M16×20		183
33	16×20	PA400VB33M16×20		225
47	16×25	PA400VB47M16×25		291
	18×20	PA400VB47M18×20		279
56	18×25	PA400VB56M18×25		327
68	18×25	PA400VB68M18×25		360

◆RATED RIPPLE CURRENT MULTIPLIERS

Frequency (Hz)	50	120	300	1k	10k	100k
10 to 47µF	0.45	1.00	1.25	1.50	1.75	1.80
56 to 150µF	0.50	1.00	1.15	1.30	1.40	1.50

KLG Series

- No sparks against DC over-voltage
- Endurance with ripple current : 105°C 2000 hours
- Non solvent-proof



◆ SPECIFICATIONS

Items	Characteristics			
Category	-25 to +105°C			
Temperature Range	-25 to +105°C			
Rated Voltage Range	200 & 400V _{dc}			
Capacitance Tolerance	±20% (M) (at 20°C, 120Hz)			
Leakage Current	I=0.04CV+100 Where, I : Max. leakage current (μA), C : Nominal capacitance (μF), V : Rated voltage (V) (at 20°C after 1 minute)			
Dissipation Factor (tanδ)	Rated voltage (V _{dc})	200V	400V	(at 20°C, 120Hz)
	tanδ (Max.)	0.20	0.24	
Low Temperature Characteristics (Max. Impedance Ratio)	Rated voltage (V _{dc})	200V	400V	(at 120Hz)
	Z(-25°C)/Z(+20°C)	4	6	
Endurance	The following specifications shall be satisfied when the capacitors are restored to 20°C after subjected to DC voltage with the rated ripple current is applied for 2000 hours at 105°C.			
	Capacitance change	≤±20% of the initial value		
	DF (tanδ)	≤200% of the initial specified value		
	Leakage current	≤The initial specified value		
Shelf Life	The following specifications shall be satisfied when the capacitors are restored to 20°C after exposing them for 1000 hours at 105°C without voltage applied.			
	Capacitance change	≤±20% of the initial value		
	DF (tanδ)	≤200% of the initial specified value		
	Leakage current	≤500% of the initial specified value		

◆ DIMENSIONS (Radial Lead Type=VB) [mm]

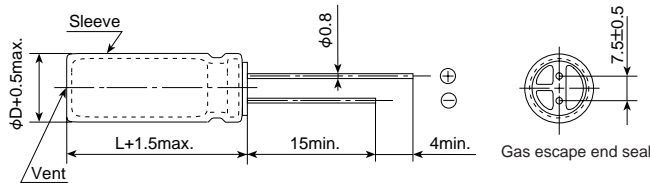

◆ PART NUMBERING SYSTEM

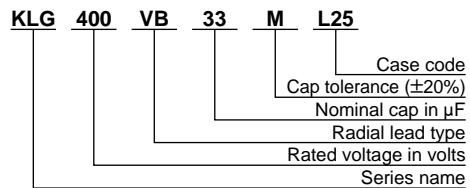

◆ STANDARD RATINGS

Items	200			
	Case size φDXL (mm)	Case code	Rated ripple current (mA _{RMS} /105°C, 120Hz)	Part number
100	16×25	L25	425	KLG200VB100ML25
120	16×31.5	L31	500	KLG200VB120ML31
	18×25	M25	475	KLG200VB120MM25
150	16×31.5	L31	560	KLG200VB150ML31
	18×25	M25	530	KLG200VB150MM25
180	16×40	L40	645	KLG200VB180ML40
	18×31.5	M31	630	KLG200VB180MM31
220	18×35.5	M35	725	KLG200VB220MM35
	18×40	M40	735	KLG200VB220MM40

Items	400			
	Case size φDXL (mm)	Case code	Rated ripple current (mA _{RMS} /105°C, 120Hz)	Part number
22	16×25	L25	200	KLG400VB22ML25
33	16×25	L25	220	KLG400VB33ML25
39	16×31.5	L31	245	KLG400VB39ML31
	18×25	M25	250	KLG400VB39MM25
47	16×31.5	L31	275	KLG400VB47ML31
56	16×40	L40	350	KLG400VB56ML40
	18×31.5	M31	315	KLG400VB56MM31
68	18×35.5	M35	350	KLG400VB68MM35
82	18×40	M40	395	KLG400VB82MM40

◆ DC OVERVOLTAGE TEST CONDITIONS

The vent will be operated and the capacitor shall become an open circuit without burning materials when the following excess DC voltage is applied.

● Test DC voltage

Rated voltage	Current limit	Test DC voltage
200V _{dc}	4A	300/375V _{dc}
400V _{dc}	2A	500/600V _{dc}

● Test circuit

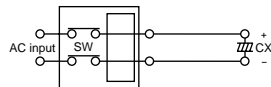

Constant DC voltage/current power supply

◆ RATED RIPPLE CURRENT MULTIPLIERS

Frequency (Hz)	50	120	300	1k	10k	50k	100k
22 to 47μF	0.75	1.00	1.25	1.50	1.75	1.80	1.85
56 to 220μF	0.80	1.00	1.15	1.30	1.40	1.50	1.60

New!

FL Series

- Long life and high reliability for $\phi 4 \times 5$ to $\phi 8 \times 20$ mm range
- Endurance with ripple current : 105°C 3000 to 6000hours
- Suitable for long life and high reliability required products
- Solvent-proof type, see page16



◆SPECIFICATIONS

Items	Characteristics	
Category Temperature Range	-40 to +105°C	
Rated Voltage Range	6.3 to 50V _{dc}	
Capacitance Tolerance	±20% (M) (at 20°C, 120Hz)	
Leakage Current	I=0.03CV or 3µA, whichever is greater. Where, I : Max. leakage current (µA), C : Nominal capacitance (µF), V : Rated voltage (V) (at 20°C after 2 minutes)	
Dissipation Factor (tanδ)	Rated voltage (V _{dc})	6.3V 10V 16V 25V 35V 50V
	tanδ (Max.)	0.50 0.40 0.35 0.30 0.25 0.25 (at 20°C, 120Hz)
Endurance	The following specifications shall be satisfied when the capacitors are restored to 20°C after subjected to DC voltage with the rated ripple current is applied for the specified period of time at 105°C.	
	Time	See STANDARD RATINGS
	Capacitance change	≤±30% of the initial value
	DF (tanδ)	≤300% of the initial specified value
	Leakage current	≤The initial specified value
Shelf Life	The following specifications shall be satisfied when the capacitors are restored to 20°C after exposing them for 1000 hours at 105°C without voltage applied.	
	Capacitance change	≤±20% of the initial value
	DF (tanδ)	≤200% of the initial specified value
	Leakage current	≤The initial specified value

◆DIMENSIONS (Radial Lead Type=VB) [mm]

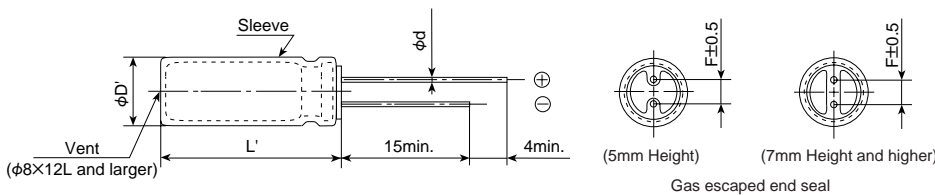

5mm Height

φD	4	5	6.3	8
φd	0.45	0.45	0.45	0.45
F	1.5	2.0	2.5	2.5
φD'	φD+0.5max.			
L'	L+1.0max.			

7mm Height

φD	4	5	6.3	8
φd	0.45	0.45	0.45	0.45
F	1.5	2.0	2.5	3.5
φD'	φD+0.5max.			
L'	L+1.0max.			

11.5mm and larger

φD	4	5	6.3	8
φd	0.45	0.5	0.5	0.6
F	1.5	2.0	2.5	3.5
φD'	φD+0.5max.			
L'	L+1.5max.			

◆PART NUMBERING SYSTEM

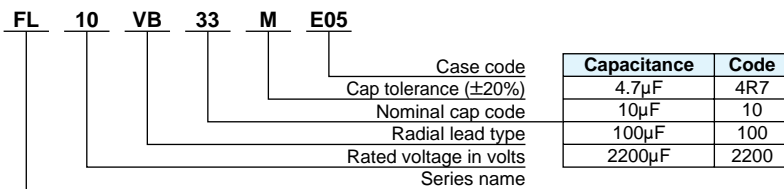

◆STANDARD RATINGS

Item Case code		6.3				10				16				25			
		Capacitance (μ F)	Impedance 20°C, 100kHz (Ω max.)	Rated ripple current (mArms/ 105°C, 100kHz)	Endurance 105°C (hours)	Capacitance (μ F)	Impedance 20°C, 100kHz (Ω max.)	Rated ripple current (mArms/ 105°C, 100kHz)	Endurance 105°C (hours)	Capacitance (μ F)	Impedance 20°C, 100kHz (Ω max.)	Rated ripple current (mArms/ 105°C, 100kHz)	Endurance 105°C (hours)	Capacitance (μ F)	Impedance 20°C, 100kHz (Ω max.)	Rated ripple current (mArms/ 105°C, 100kHz)	Endurance 105°C (hours)
ϕ DXL(mm)																	
4X5	D05	33	5.4	37	3,000	22	5.4	37	3,000	15	5.4	37	3,000	10	5.4	37	3,000
4X7	D07	47	4.5	44	3,000	33	4.5	44	3,000	22	4.5	44	3,000	15	4.5	44	3,000
4X11.5	D11	120	2.2	83	5,000	100	2.2	83	5,000	68	2.2	83	5,000	39	2.2	83	5,000
5X5	E05	56	3.1	57	3,000	33	3.1	57	3,000	22	3.1	57	3,000	15	3.1	57	3,000
5X7	E07	82	2.5	70	3,000	47	2.5	70	3,000	33	2.5	70	3,000	22	2.5	70	3,000
5X11.5	E11	220	1.5	115	5,000	180	1.5	115	5,000	120	1.5	115	5,000	68	1.5	115	5,000
5X15	E15	270	1.2	149	6,000	220	1.2	149	6,000	180	1.2	149	6,000	100	1.2	149	6,000
6.3X5	F05	100	1.7	82	3,000	68	1.7	82	3,000	47	1.7	82	3,000	33	1.7	82	3,000
6.3X7	F07	150	1.3	116	3,000	100	1.3	116	3,000	68	1.3	116	3,000	56	1.3	116	3,000
6.3X11.5	F11	470	0.72	190	5,000	390	0.72	190	5,000	270	0.72	190	5,000	120	0.72	190	5,000
6.3X15	F15	560	0.53	245	6,000	470	0.53	245	6,000	390	0.53	245	6,000	180	0.53	245	6,000
8X5	H05	220	1.5	110	3,000	150	1.5	110	3,000	100	1.5	110	3,000	68	1.5	110	3,000
8X7	H07	270	0.90	162	3,000	220	0.90	162	3,000	150	0.90	162	3,000	100	0.90	162	3,000
8X12	H12	1,000	0.41	287	6,000	680	0.41	287	6,000	470	0.41	287	6,000	270	0.41	287	6,000
8X15	H15	1,200	0.30	365	6,000	1,000	0.30	365	6,000	680	0.30	365	6,000	390	0.30	365	6,000
8X20	H20	1,500	0.23	417	6,000	1,200	0.23	417	6,000	820	0.23	417	6,000	470	0.23	417	6,000

Item Case code		35				50			
		Capacitance (μ F)	Impedance 20°C, 100kHz (Ω max.)	Rated ripple current (mArms/ 105°C, 100kHz)	Endurance 105°C (hours)	Capacitance (μ F)	Impedance 20°C, 100kHz (Ω max.)	Rated ripple current (mArms/ 105°C, 100kHz)	Endurance 105°C (hours)
ϕ DXL(mm)									
4X5	D05	4.7	5.4	37	3,000	3.3	11	26	3,000
4X7	D07	6.8	4.5	44	3,000	4.7	9.0	30	3,000
4X11.5	D11	22	2.2	83	5,000	12	3.7	67	5,000
5X5	E05	10	3.1	57	3,000	4.7	6.0	40	3,000
5X7	E07	10	2.5	70	3,000	6.8	4.8	50	3,000
5X11.5	E11	47	1.5	115	5,000	27	2.6	87	5,000
5X15	E15	56	1.2	149	6,000	33	2.0	115	6,000
6.3X5	F05	22	1.7	82	3,000	10	2.9	63	3,000
6.3X7	F07	22	1.3	116	3,000	15	2.2	90	3,000
6.3X11.5	F11	100	0.72	190	5,000	47	1.2	147	5,000
6.3X15	F15	120	0.53	245	6,000	68	0.89	189	6,000
8X5	H05	33	1.5	110	3,000	22	2.6	84	3,000
8X7	H07	47	0.90	162	3,000	22	1.6	120	3,000
8X12	H12	180	0.41	287	6,000	100	0.68	223	6,000
8X15	H15	220	0.30	365	6,000	120	0.51	280	6,000
8X20	H20	330	0.23	417	6,000	180	0.38	371	6,000

Item Case code		50(Small capacitance)			
		Capacitance (μ F)	Impedance 20°C, 100kHz (Ω max.)	Rated ripple current (mArms/ 105°C, 100kHz)	Endurance 105°C (hours)
ϕ DXL(mm)					
4X5	D05	0.47	34	14	3,000
		1.0	19	18	3,000
		2.2	14	22	3,000
5X11.5	E11	0.47	14	36	5,000
		1.0	8.0	48	5,000
		2.2	6.0	56	5,000
		3.3	5.0	62	5,000
		4.7	4.0	68	5,000
10	2.5	90	5,000		

◆RATED RIPPLE CURRENT MULTIPLIERS

●Frequency Multipliers

Capacitance(μ F)	Frequency(Hz)			
	120	1k	10k	100k
to 3.3	0.20	0.66	0.90	1.00
4.7 to 6.8	0.35	0.70	0.90	1.00
10 to 180	0.40	0.75	0.90	1.00
220 to 560	0.50	0.85	0.94	1.00
680 to 1500	0.60	0.87	0.95	1.00

LXA/LX Series

- Endurance : 105°C 5000 to 7000 hours
- Solvent-proof type, see page 16



◆ SPECIFICATIONS

Items	Characteristics	
Series	LXA	LX
Category Temperature Range	-55 to +105°C	-40 to +105°C
Rated Voltage Range	10 to 63V _{dc}	100 to 250V _{dc}
Capacitance Tolerance	±20% (M) (at 20°C, 120Hz)	±20% (M) (at 20°C, 120Hz)
Leakage Current	I=0.01CV or 3µA, whichever is greater. (at 20°C after 2 minutes)	I=0.01CV+2µA (100V _{dc}) I=0.04CV+100µA (160 to 250V _{dc}) (at 20°C after 2 minutes)
Where, I : Max. leakage current (µA), C : Nominal capacitance (µF), V : Rated voltage (V)		
Dissipation Factor (tanδ)	Rated Voltage (V _{dc})	10V 16V 25V 35V 50V 63V 100V 160V 200V 250V
	tanδ (Max.)	0.30 0.25 0.22 0.18 0.15 0.12 0.12 0.15 0.15 0.15
When nominal capacitance exceeds 1000µF, add 0.02 to the value above for each 1000µF increase. (at 20°C, 120Hz)		
Low Temperature Characteristics	Capacitance change ΔC (-10°C/+20°C) ≥ 0.8 (at 120Hz)	
Endurance	The following specifications shall be satisfied when the capacitors are restored to 20°C after the rated voltage is applied for the specified period of time at 105°C.	
	Series	LXA LX
	Time	7000 hours (φ12.5 and larger) 5000hours 5000 hours
	Capacitance change	≤±30% of the initial value ≤±30% of the initial value
	DF (tanδ)	≤300% of the initial specified value ≤250% of the initial specified value
	Leakage current	≤The initial specified value ≤The initial specified value
Shelf Life	The following specifications shall be satisfied when the capacitors are restored to 20°C after exposing them for 1000 hours at 105°C without voltage applied.	
	Series	LXA LX
	Capacitance change	≤±15% of the initial value ≤±20% of the initial value
	DF (tanδ)	≤150% of the initial specified value ≤150% of the initial specified value
	Leakage current	≤The initial specified value ≤The initial specified value

◆ DIMENSIONS (Radial Lead Type=VB) [mm]

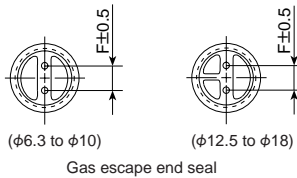
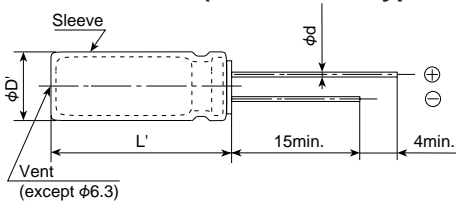

φD	6.3	8	10	12.5	16	18
φd	0.5	0.6	0.6	0.6	0.8	0.8
F	2.5	3.5	5.0	5.0	7.5	7.5
φD'	φD+0.5max.					
L'	LXA	L+1.5max.				
	LX	-	L+1.5max.	L+2.0max.		

◆ PART NUMBERING SYSTEM

LXA 50 VB 2R2 M

Cap tolerance (±20%)
Nominal cap code
Radial lead type
Rated voltage in volts
Series name

Capacitance	Code
0.47µF	R47
1.0µF	1
4.7µF	4R7
10µF	10
100µF	100

◆ STANDARD RATINGS 10 to 63V_{dc}

V _{dc} Items μF	10			16			25			35		
	Case size φDXL (mm)	Impedance (Q _{max.} /100kHz 20°C)	Rated ripple (Arms/105°C 100kHz)	Case size φDXL (mm)	Impedance (Q _{max.} /100kHz 20°C)	Rated ripple (Arms/105°C 100kHz)	Case size φDXL (mm)	Impedance (Q _{max.} /100kHz 20°C)	Rated ripple (Arms/105°C 100kHz)	Case size φDXL (mm)	Impedance (Q _{max.} /100kHz 20°C)	Rated ripple (Arms/105°C 100kHz)
4.7										6.3X15	1.65	0.14
10							6.3X15	1.65	0.14	6.3X15	1.65	0.14
22							6.3X15	1.65	0.14	6.3X15	1.65	0.14
33				6.3X15	1.65	0.14	6.3X15	1.65	0.14	6.3X15	1.65	0.14
47	6.3X15	1.65	0.14	6.3X15	1.65	0.14	6.3X15	1.65	0.14	6.3X15	1.65	0.14
100	6.3X15	1.65	0.14	6.3X15	1.65	0.14	8X15	0.90	0.21	8X15	0.90	0.21
220	8X15	0.90	0.21	8X15	0.90	0.21	10X16	0.42	0.37	10X20	0.28	0.49
330	10X16	0.42	0.37	10X16	0.42	0.37	10X20	0.28	0.49	12.5X20	0.16	0.72
470	10X16	0.42	0.37	10X20	0.28	0.49	12.5X20	0.16	0.72	12.5X20	0.16	0.72
1,000	12.5X20	0.16	0.72	12.5X25	0.13	0.78	16X25	0.08	1.22	16X25	0.08	1.22
2,200	16X25	0.08	1.22	16X25	0.08	1.22	16X35.5	0.06	1.55	18X35.5	0.055	1.69
3,300	16X31.5	0.07	1.40	16X35.5	0.06	1.55	18X40	0.05	1.80			
4,700	16X35.5	0.06	1.55	18X35.5	0.055	1.69						

► LXA-series

V _{dc} Items μF	50			63		
	Case size φDXL (mm)	Impedance (Q _{max.} /100kHz 20°C)	Rated ripple (Arms/105°C 100kHz)	Case size φDXL (mm)	Impedance (Q _{max.} /100kHz 20°C)	Rated ripple (Arms/105°C 100kHz)
0.47	6.3X15	4.5	0.14			
1.0	6.3X15	2.6	0.14			
2.2	6.3X15	1.8	0.14			
3.3	6.3X15	1.8	0.14			
4.7	6.3X15	1.65	0.14	6.3X15	1.65	0.14
10	6.3X15	1.65	0.14	6.3X15	1.65	0.14
22	6.3X15	1.65	0.14	6.3X15	1.65	0.14
33	8X15	0.90	0.21	8X15	0.90	0.21
47	8X15	0.90	0.21	8X15	0.90	0.21
100	10X16	0.55	0.32	10X20	0.37	0.42
220	12.5X20	0.20	0.64	12.5X20	0.20	0.64
330	12.5X20	0.20	0.64	12.5X25	0.16	0.72
470	16X25	0.09	1.15	16X25	0.09	1.15
1,000	16X31.5	0.07	1.40	18X35.5	0.055	1.69

◆ STANDARD RATINGS 100 to 250V_{dc}

V _{dc} Items μF	100			
	Case size φDXL (mm)	Impedance (Q _{max.} /100kHz 20°C)	Impedance (Q _{max.} /100kHz -10°C)	Rated ripple (Arms/105°C 100kHz)
0.47	8X15	35.0	105.0	0.03
1.0	8X15	18.0	54.0	0.05
2.2	8X15	9.62	28.8	0.06
3.3	8X15	8.57	25.7	0.07
4.7	8X15	6.43	19.3	0.08
10	10X20	2.99	8.97	0.23
22	12.5X20	1.47	4.41	0.25
33	12.5X25	1.00	3.00	0.33
47	16X25	0.69	2.07	0.44

◁ LX-series

V _{dc} Items μF	160			200			250					
	Case size φDXL (mm)	Impedance (Q _{max.} /100kHz 20°C)	Rated ripple (Arms/105°C 100kHz)	Case size φDXL (mm)	Impedance (Q _{max.} /100kHz 20°C)	Rated ripple (Arms/105°C 100kHz)	Case size φDXL (mm)	Impedance (Q _{max.} /100kHz 20°C)	Rated ripple (Arms/105°C 100kHz)			
1.0				10X16	18.0	70.0	0.03	10X16	20.0	80.0	0.03	
2.2				10X16	16.0	65.0	0.04	10X16	18.0	70.0	0.04	
3.3				10X16	9.2	32.0	0.05	10X20	9.0	27.0	0.06	
4.7				10X20	4.7	14.0	0.08	12.5X20	5.0	15.0	0.09	
10	12.5X20	3.5	10.0	0.13	12.5X20	2.6	7.6	0.14	12.5X25	2.5	7.0	0.15
22	16X25	1.8	4.8	0.25	16X25	1.9	5.0	0.25	16X31.5	1.8	4.8	0.26
33	16X25	1.7	4.5	0.32	16X31.5	1.2	3.0	0.33	16X35.5	1.0	2.8	0.34
47	16X31.5	1.1	2.9	0.40	18X35.5	1.0	2.5	0.43	18X40	0.8	2.0	0.44
68	18X35.5	0.9	1.9	0.51	18X40	0.7	1.8	0.52				

◆ RATED RIPPLE CURRENT MULTIPLIERS

● LXA-series : Frequency Multipliers

Capacitance (μF)	Frequency (Hz)				
	50	120	300	1k	10k
0.47 to 4.7	0.1	0.2	0.3	0.5	1.0
10 to 22	0.2	0.3	0.4	0.6	1.0
33 to 47	0.3	0.4	0.5	0.7	1.0
100 to 330	0.4	0.5	0.6	0.8	1.0
470 to	0.6	0.7	0.8	0.9	1.0

● LX-series : Frequency Multipliers

Capacitance (μF)	Frequency (Hz)				
	50	120	300	1k	10k
0.47 to 3.3	0.3	0.4	0.5	0.7	1.0
4.7 to 33	0.4	0.5	0.6	0.8	1.0
47 to	0.6	0.7	0.8	0.9	1.0

EX Series

- Fully compatible with case size of KME
- Endurance with ripple current : 105°C 2000 to 5000 hours (125°C capability)
- For automobile modules and other high reliability equipment
- -40°C ESR is specified for $\phi 12.5$ and larger

EX

↑ longer life
KME

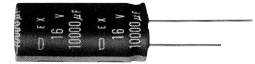

◆ SPECIFICATIONS

Items	Characteristics																								
Category																									
Temperature Range	-55 to +105°C																								
Rated Voltage Range	10 to 63V _{dc}																								
Capacitance Tolerance	±20% (M) (at 20°C, 120Hz)																								
Leakage Current	$I = 0.01CV$ or 3μA, whichever is greater. Where, I : Max. leakage current (μA), C : Nominal capacitance (μF), V : Rated voltage (V) (at 20°C after 2 minutes)																								
Dissipation Factor (tanδ)	<table border="1"> <tr> <td>Rated voltage (V_{dc})</td> <td>10V</td> <td>16V</td> <td>25V</td> <td>35V</td> <td>50V</td> <td>63V</td> </tr> <tr> <td>tanδ (Max.)</td> <td>0.38</td> <td>0.32</td> <td>0.28</td> <td>0.24</td> <td>0.20</td> <td>0.16</td> </tr> </table> <p>When nominal capacitance exceeds 1000μF, add 0.02 to the value above for each 1000μF increase. (at 20°C, 120Hz)</p>	Rated voltage (V _{dc})	10V	16V	25V	35V	50V	63V	tanδ (Max.)	0.38	0.32	0.28	0.24	0.20	0.16										
Rated voltage (V _{dc})	10V	16V	25V	35V	50V	63V																			
tanδ (Max.)	0.38	0.32	0.28	0.24	0.20	0.16																			
Low Temperature Characteristics	Capacitance change : $C(-40°C)/C(+20°C) \geq 0.70$ (at 120Hz)																								
ESR	Shall not exceed the values shown in the STANDARD RATINGS (at -40°C & 20°C/ 100kHz)																								
Endurance	<p>After the capacitors are subjected to the rated voltage with the rated ripple current applied at 105°C or with 50% of the rated ripple current applied at 125°C for the specified period of time, the following specifications shall be satisfied when the capacitors are restored to 20°C.</p> <table border="1"> <tr> <td>Time at 105°C</td> <td>$\phi 5$ & 6.3 : 2000 hours</td> <td>$\phi 8$ & 10 : 3000 hours</td> <td>$\phi 12.5$ and larger: 5000 hours</td> </tr> <tr> <td>Time at 125°C</td> <td>$\phi 5$ & 6.3 : 500 hours</td> <td>$\phi 8$ & 10 : 750 hours</td> <td>$\phi 12.5$ and larger : 1250 hours</td> </tr> <tr> <td>Capacitance change</td> <td colspan="3">$\leq \pm 20\%$ of the initial value</td> </tr> <tr> <td>DF (tanδ)</td> <td colspan="3">$\leq 200\%$ of the initial specified value</td> </tr> <tr> <td>Leakage current</td> <td colspan="3">\leq The initial specified value</td> </tr> <tr> <td>ESR</td> <td colspan="3">\leq The initial specified value (Applied to 12.5mm diameter and larger)</td> </tr> </table>	Time at 105°C	$\phi 5$ & 6.3 : 2000 hours	$\phi 8$ & 10 : 3000 hours	$\phi 12.5$ and larger: 5000 hours	Time at 125°C	$\phi 5$ & 6.3 : 500 hours	$\phi 8$ & 10 : 750 hours	$\phi 12.5$ and larger : 1250 hours	Capacitance change	$\leq \pm 20\%$ of the initial value			DF (tanδ)	$\leq 200\%$ of the initial specified value			Leakage current	\leq The initial specified value			ESR	\leq The initial specified value (Applied to 12.5mm diameter and larger)		
Time at 105°C	$\phi 5$ & 6.3 : 2000 hours	$\phi 8$ & 10 : 3000 hours	$\phi 12.5$ and larger: 5000 hours																						
Time at 125°C	$\phi 5$ & 6.3 : 500 hours	$\phi 8$ & 10 : 750 hours	$\phi 12.5$ and larger : 1250 hours																						
Capacitance change	$\leq \pm 20\%$ of the initial value																								
DF (tanδ)	$\leq 200\%$ of the initial specified value																								
Leakage current	\leq The initial specified value																								
ESR	\leq The initial specified value (Applied to 12.5mm diameter and larger)																								
Shelf Life	<p>The following specifications shall be satisfied when the capacitors are restored to 20°C after exposing them for 1000 hours at 105°C without voltage applied.</p> <table border="1"> <tr> <td>Capacitance change</td> <td>$\leq \pm 20\%$ of the initial value</td> </tr> <tr> <td>DF (tanδ)</td> <td>$\leq 200\%$ of the initial specified value</td> </tr> <tr> <td>Leakage current</td> <td>\leq The initial specified value</td> </tr> <tr> <td>ESR</td> <td>\leq The initial specified value (Applied to 12.5mm diameter and larger)</td> </tr> </table>	Capacitance change	$\leq \pm 20\%$ of the initial value	DF (tanδ)	$\leq 200\%$ of the initial specified value	Leakage current	\leq The initial specified value	ESR	\leq The initial specified value (Applied to 12.5mm diameter and larger)																
Capacitance change	$\leq \pm 20\%$ of the initial value																								
DF (tanδ)	$\leq 200\%$ of the initial specified value																								
Leakage current	\leq The initial specified value																								
ESR	\leq The initial specified value (Applied to 12.5mm diameter and larger)																								

◆ DIMENSIONS (Radial Lead Type=VB) [mm]

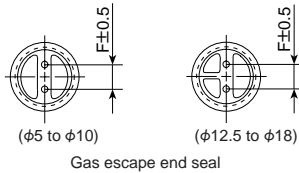
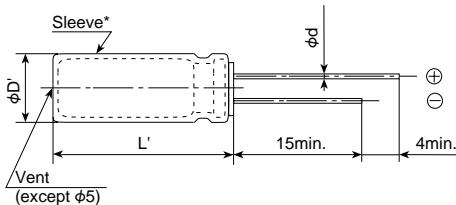

ϕD	5	6.3	8	10	12.5	16	18
ϕd	0.5	0.5	0.6	0.6	0.6	0.8	0.8
F	2.0	2.5	3.5	5.0	5.0	7.5	7.5
$\phi D'$	$\phi D + 0.5 \text{ max.}$						
L'	$L + 2.0 \text{ max.}$						

* : PET sleeve (orange) is available upon request if the 125°C load life is required.

◆ PART NUMBERING SYSTEM

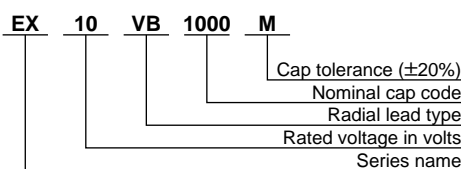

Capacitance	Code
0.1μF	R1
0.47μF	R47
1.0μF	1
4.7μF	4R7
10μF	10
100μF	100

◆STANDARD RATINGS

Items Capacitance (μF)	V _{dc} Case size φDXL (mm)	10						16						25							
		Initial value				End of life		Initial value				End of life		Initial value				End of life			
		ESR (Ω _{max} /100kHz)		Rated ripple (mArms/105°C)		ESR (Ω _{max} /100kHz)		ESR (Ω _{max} /100kHz)		Rated ripple (mArms/105°C)		ESR (Ω _{max} /100kHz)		ESR (Ω _{max} /100kHz)		Rated ripple (mArms/105°C)		ESR (Ω _{max} /100kHz)			
		20°C	-40°C	100kHz	120Hz	20°C	-40°C	20°C	-40°C	100kHz	120Hz	20°C	-40°C	20°C	-40°C	100kHz	120Hz	20°C	-40°C		
47								5X11	2.7	41	86	43	-	-	5X11	2.7	41	86	43	-	-
100	5X11	2.7	41	86	60	-	-	6.3X11	1.2	18	147	74	-	-	6.3X11	1.2	18	147	74	-	-
220	6.3X11	1.2	18	147	102	-	-	8X11.5	0.58	8.7	242	121	-	-	8X11.5	0.58	8.7	242	121	-	-
330	8X11.5	0.58	8.7	242	169	-	-	8X11.5	0.58	8.7	242	121	-	-	10X12.5	0.40	6.0	344	241	-	-
470	8X11.5	0.58	8.7	242	169	-	-	10X12.5	0.40	6.0	344	241	-	-	10X16	0.28	4.2	453	317	-	-
1,000	10X16	0.28	4.2	453	385	-	-	10X20	0.20	3.0	581	408	-	-	12.5X20	0.12	1.8	832	582	0.24	3.6
2,200	12.5X20	0.12	1.8	832	706	0.24	3.6	12.5X25	0.089	1.4	1,050	734	0.18	2.8	16X25	0.065	0.98	1,360	951	0.13	2.0
3,300	12.5X25	0.089	1.4	1,050	892	0.18	2.8	16X25	0.065	0.98	1,360	951	0.13	2.0	16X31.5	0.050	0.75	1,670	1,170	0.10	1.5
4,700	16X25	0.065	0.98	1,360	1,160	0.13	2.0	16X31.5	0.050	0.75	1,670	1,170	0.10	1.5	18X35.5	0.040	0.60	1,990	1,390	0.080	1.2
6,800	16X31.5	0.050	0.75	1,670	1,420	0.10	1.5	18X35.5	0.040	0.60	1,990	1,390	0.080	1.2	18X40	0.036	0.54	2,130	1,490	0.072	1.1
10,000	18X35.5	0.040	0.60	1,990	1,690	0.080	1.2	18X40	0.036	0.54	2,130	1,490	0.072	1.1							

Items Capacitance (μF)	V _{dc} Case size φDXL (mm)	35						50						63							
		Initial value				End of life		Initial value				End of life		Initial value				End of life			
		ESR (Ω _{max} /100kHz)		Rated ripple (mArms/105°C)		ESR (Ω _{max} /100kHz)		ESR (Ω _{max} /100kHz)		Rated ripple (mArms/105°C)		ESR (Ω _{max} /100kHz)		ESR (Ω _{max} /100kHz)		Rated ripple (mArms/105°C)		ESR (Ω _{max} /100kHz)			
		20°C	-40°C	100kHz	120Hz	20°C	-40°C	20°C	-40°C	100kHz	120Hz	20°C	-40°C	20°C	-40°C	100kHz	120Hz	20°C	-40°C		
0.1														5X11	21	315	30	6.0	-	-	
0.22														5X11	16	240	35	7.0	-	-	
0.33														5X11	12	180	40	8.0	-	-	
0.47														5X11	10	150	44	9.0	-	-	
1.0														5X11	7.0	105	53	10	-	-	
2.2														5X11	6.0	90	57	22	-	-	
3.3														5X11	5.0	75	63	25	-	-	
4.7														5X11	4.0	60	70	28	-	-	
10														5X11	2.7	41	86	34	-	-	
22								5X11	2.7	41	86	34	-	-	6.3X11	1.2	18	147	58	-	-
33	5X11	2.7	41	86	43	-	-	6.3X11	1.2	18	147	59	-	-	6.3X11	1.2	18	147	58	-	-
47	6.3X11	1.2	18	147	74	-	-	6.3X11	1.2	18	147	59	-	-	8X11.5	0.58	8.7	242	96	-	-
100	8X11.5	0.58	8.7	242	121	-	-	8X11.5	0.58	8.7	242	97	-	-	10X12.5	0.40	6.0	344	206	-	-
220	10X12.5	0.40	6.0	344	241	-	-	10X16	0.28	4.2	453	272	-	-	10X20	0.20	3.0	581	348	-	-
330	10X16	0.28	4.2	453	317	-	-	10X20	0.20	3.0	581	349	-	-	12.5X20	0.12	1.8	832	499	0.24	3.6
470	10X20	0.20	3.0	581	407	-	-	12.5X20	0.12	1.8	832	499	0.24	3.6	12.5X25	0.089	1.4	1,050	629	0.18	2.8
1,000	12.5X25	0.089	1.4	1,050	734	0.18	2.8	16X25	0.065	0.98	1,360	815	0.13	2.0	16X31.5	0.050	0.75	1,670	1,000	0.10	1.5
2,200	16X25	0.065	0.98	1,360	1,170	0.10	1.5	18X35.5	0.040	0.60	1,990	1,200	0.080	1.2							
3,300	18X35.5	0.040	0.60	1,990	1,390	0.080	1.2														
4,700	18X40	0.036	0.54	2,130	1,490	0.072	1.1														

◆RATED RIPPLE CURRENT MULTIPLIERS

●Frequency Multipliers

Rated voltage (V _{dc})	Case size	Frequency(Hz)			
		120	1k	10k	100k
10	φ5, φ6.3 & φ8	0.70	0.86	0.96	1.00
	φ10 to φ18	0.85	0.95	0.98	1.00
16 to 35	φ5 to φ8	0.50	0.80	0.94	1.00
	φ10 to φ18	0.70	0.88	0.97	1.00
50 & 63	φ5 (1μF and below)	0.20	0.66	0.90	1.00
	φ5 (2.2μF and up), φ6.3 & φ8	0.40	0.76	0.93	1.00
	φ10 to φ18	0.60	0.84	0.96	1.00

Upgrade!

GXE Series

- For automobile modules and other high temperature applications
- Downsize, longer life, lower impedance, and better low temperature characteristics version of GXD series
- Endurance with ripple current : 125°C 2000 to 5000 hours

GXE

↑ downsized longer life
GXD



◆ SPECIFICATIONS

Items	Characteristics										
Category	-40 to +125°C (10 to 250V _{dc}) -25 to +125°C (350 to 450V _{dc})										
Temperature Range											
Rated Voltage Range	10 to 450V _{dc}										
Capacitance Tolerance	±20% (M) (at 20°C, 120Hz)										
Leakage Current	10 to 100V _{dc}					160 to 450V _{dc}					
	I=0.03CV or 4μA, whichever is greater.										
						CV≤1000		I=0.1CV+40			
						CV>1000		I=0.04CV+100			
	Where, I : Max. leakage current (μA), C : Nominal capacitance (μF), V : Rated voltage (V) (at 20°C, 1 minute)										
Dissipation Factor (tanδ)	Rated voltage (V _{dc})	10V	16V	25V	35V	50V	63V	80V	100V	160 to 250V	350 to 450V
	tanδ (Max.)	0.20	0.16	0.14	0.12	0.10	0.10	0.08	0.08	0.20	0.24
	When nominal capacitance exceed 1000μF, 0.02 shall be added each 1000μF increase. (at 20°C, 120Hz)										
Low Temperature Characteristics (Max. Impedance Ratio)	Rated voltage (V _{dc})	10V	16V	25V	35V	50V	63V	80V	100V	160 to 250V	350 to 450V
	Z(-25°C)/Z(+20°C)	3	2	2	2	2	2	2	2	3	6
	Z(-40°C)/Z(+20°C)	6	4	4	4	4	4	4	4	6	—
	(at 120Hz)										
Endurance	The following specifications shall be satisfied when the capacitors are restored to 20°C after subjected to DC voltage with the rated ripple current is applied for the specified time at 125°C.										
		10 to 100V _{dc}					160 to 450V _{dc}				
	Time	φ8 : 2000hours φ10 : 3000hours φ12.5 & φ16 : 5000hours					2000hours				
	Capacitance change	≤±30% of the initial value					≤±20% of the initial value				
	DF (tanδ)	≤300% of the initial specified value					≤200% of the initial specified value				
	Leakage current	≤The initial specified value					≤The initial specified value				
Shelf Life	The following specifications shall be satisfied when the capacitors are restored to 20°C after exposing them for 1000 hours (500 hours for 350 to 450VV) at 125°C without voltage applied.										
		10 to 100V _{dc}					160 to 450V _{dc}				
	Capacitance change	≤±30% of the initial value					≤±20% of the initial value				
	DF (tanδ)	≤300% of the initial specified value					≤200% of the initial specified value				
	Leakage current	≤The initial specified value					≤500% of the initial specified value				

◆ DIMENSIONS (Radial Lead Type=VB) [mm]

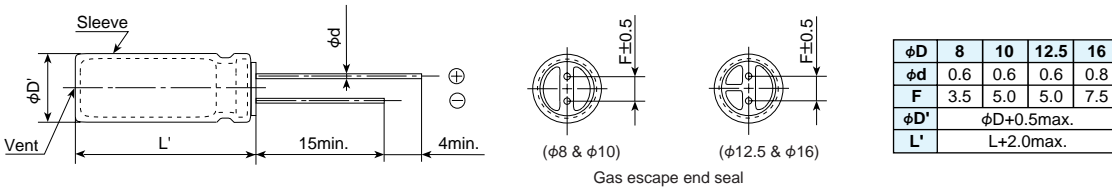

◆ PART NUMBERING SYSTEM

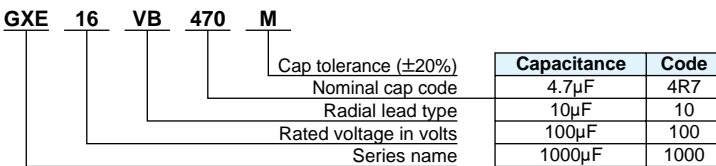

◆ RATED RIPPLE CURRENT MULTIPLIERS

● (10 to 100V_{dc}) Frequency Multipliers

Capacitance (μF)	Frequency (Hz)			
	120	1k	10k	100k
4.7 to 100	0.40	0.75	0.90	1.00
220 to 470	0.50	0.85	0.94	1.00
1000	0.60	0.87	0.95	1.00
2200 to 3300	0.75	0.90	0.95	1.00
4700	0.85	0.95	0.98	1.00

● (160 to 450V_{dc}) Frequency Multipliers

Capacitance (μF)	Frequency (Hz)					
	50	120	300	1k	10k	100k
4.7 to 33	0.75	1.00	1.25	1.50	1.75	1.80
47 to 150	0.80	1.00	1.15	1.30	1.40	1.50



Upgrade!

GXE Series

◆STANDARD RATINGS

Items Capacitance (μF)	10			16			25			35		
	Case size φD×L (mm)	Impedance (Ωmax./ 20°C, 100kHz)	Rated ripple (mArms/ 125°C, 100kHz)	Case size φD×L (mm)	Impedance (Ωmax./ 20°C, 100kHz)	Rated ripple (mArms/ 125°C, 100kHz)	Case size φD×L (mm)	Impedance (Ωmax./ 20°C, 100kHz)	Rated ripple (mArms/ 125°C, 100kHz)	Case size φD×L (mm)	Impedance (Ωmax./ 20°C, 100kHz)	Rated ripple (mArms/ 125°C, 100kHz)
100				8×12	0.32	340	8×12	0.32	340	8×12	0.32	340
220	8×12	0.32	340	10×12.5	0.15	620	10×12.5	0.15	620	10×12.5	0.15	620
330	10×12.5	0.15	620	10×12.5	0.15	620	10×16	0.094	790	10×16	0.094	790
470	10×12.5	0.15	620	10×16	0.094	790	10×20	0.075	950	10×20	0.075	950
1,000	10×20	0.075	950	12.5×20	0.058	1,080	12.5×25	0.040	1,350	12.5×25	0.040	1,350
2,200	12.5×25	0.040	1,350	16×25	0.031	1,620	16×31.5	0.025	1,860	16×25	0.031	1,620
3,300	16×25	0.031	1,620	16×31.5	0.025	1,860						
4,700	16×31.5	0.025	1,860									

Items Capacitance (μF)	50			63			80			100		
	Case size φD×L (mm)	Impedance (Ωmax./ 20°C, 100kHz)	Rated ripple (mArms/ 125°C, 100kHz)	Case size φD×L (mm)	Impedance (Ωmax./ 20°C, 100kHz)	Rated ripple (mArms/ 125°C, 100kHz)	Case size φD×L (mm)	Impedance (Ωmax./ 20°C, 100kHz)	Rated ripple (mArms/ 125°C, 100kHz)	Case size φD×L (mm)	Impedance (Ωmax./ 20°C, 100kHz)	Rated ripple (mArms/ 125°C, 100kHz)
4.7										8×12	2.0	130
10	8×12	0.75	180							8×12	1.5	150
22	8×12	0.50	250				8×12	1.50	150	10×12.5	0.80	480
33	8×12	0.50	280	8×12	1.5	150	10×12.5	0.80	480	10×12.5	0.80	480
47	8×12	0.50	280	10×12.5	0.59	530	10×12.5	0.80	480	10×16	0.55	630
100	10×12.5	0.20	520	10×16	0.41	690	10×20	0.39	790	12.5×20	0.25	990
220	10×20	0.098	880	12.5×20	0.16	1,050	12.5×25	0.18	1,240	16×25	0.11	1,500
330	12.5×20	0.081	990	12.5×25	0.12	1,290	12.5×30	0.16	1,390	16×31.5	0.079	1,790
470	12.5×25	0.059	1,150	12.5×30	0.097	1,460	16×25	0.11	1,500			
1,000	16×31.5	0.032	1,590	16×31.5	0.059	1,850						

Items Capacitance (μF)	160			200			250			350		
	Case size φD×L (mm)	Impedance (Ωmax./ 20°C, 100kHz)	Rated ripple (mArms/ 125°C, 120Hz)	Case size φD×L (mm)	Impedance (Ωmax./ 20°C, 100kHz)	Rated ripple (mArms/ 125°C, 120Hz)	Case size φD×L (mm)	Impedance (Ωmax./ 20°C, 100kHz)	Rated ripple (mArms/ 125°C, 120Hz)	Case size φD×L (mm)	Impedance (Ωmax./ 20°C, 100kHz)	Rated ripple (mArms/ 125°C, 120Hz)
4.7										10×20	4.7	53
10				10×20	3.3	78	10×20	3.3	78	10×25	3.4	85
22	10×20	4.0	115	10×25	2.3	126	12.5×20	1.8	128	12.5×25	1.9	139
33	10×25	2.6	154	12.5×20	1.8	157	12.5×25	1.2	171	16×25	1.1	189
47	12.5×20	1.8	187	12.5×25	1.2	204	16×25	0.76	225	16×31.5	0.81	243
68	12.5×25	1.3	245	16×20	1.1	250	16×31.5	0.54	292			
100	16×25	0.90	329	16×25	0.74	329						
150	16×31.5	0.59	434									

Items Capacitance (μF)	400			450		
	Case size φD×L (mm)	Impedance (Ωmax./ 20°C, 100kHz)	Rated ripple (mArms/ 125°C, 120Hz)	Case size φD×L (mm)	Impedance (Ωmax./ 20°C, 100kHz)	Rated ripple (mArms/ 125°C, 120Hz)
4.7	10×20	5.5	53	10×25	5.5	58
10	10×25	3.5	86	12.5×20	4.0	86
22	12.5×30	1.6	142	16×25	1.9	154
33	16×25	1.2	189	16×31.5	1.3	203
47	16×31.5	0.85	243			

GXD Series

- Endurance : 125°C 1000 to 2000 hours
- Operating temperature range, -40 to 125°C
- For automobile modules and other high temperature applications
- Non solvent-proof

GXE
↓
downsized
longer life
GXD



◆ SPECIFICATIONS

Items	Characteristics							
Category	-40 to +125°C							
Temperature Range	-40 to +125°C							
Rated Voltage Range	10 to 63V _{dc}							
Capacitance Tolerance	±20% (M) (at 20°C, 120Hz)							
Leakage Current	I=0.03CV or 4μA, whichever is greater. Where, I : Max. leakage current (μA), C : Nominal capacitance (μF), V : Rated voltage (V) (at 20°C after 1 minute)							
Dissipation Factor (tanδ)	Rated voltage (V _{dc})	10V	16V	25V	35V	50V	63V	(at 20°C, 120Hz)
	tanδ (Max.)	0.15	0.12	0.10	0.10	0.08	0.08	
Low Temperature Characteristics (Max. Impedance Ratio)	Rated voltage (V _{dc})	10V	16V	25V	35V	50V	63V	(at 120Hz)
	Z(-25°C)/Z(+20°C)	3	2	2	2	2	2	
	Z(-40°C)/Z(+20°C)	6	4	4	4	4	4	
Endurance	After the capacitors are subjected to the rated voltage at 125°C for specified period of time, the following specifications shall be satisfied when the capacitors are restored to 20°C.							
	Time	φ10×12.5 and smaller : 1000 hours			φ10×16 and larger : 2000 hours			
	Capacitance change	≤±20% of the initial value						
	DF (tanδ)	≤200% of the initial specified value						
	Leakage current	≤The initial specified value						
Shelf Life	The following specifications shall be satisfied when the capacitors are restored to 20°C after exposing them for 1000 hours at 125°C without voltage applied.							
	Capacitance change	≤±20% of the initial value						
	DF (tanδ)	≤200% of the initial specified value						
	Leakage current	≤500% of the initial specified value						

◆ DIMENSIONS (Radial Lead Type=VB) [mm]

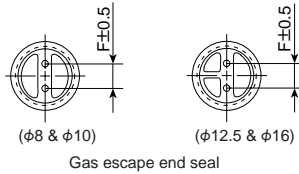
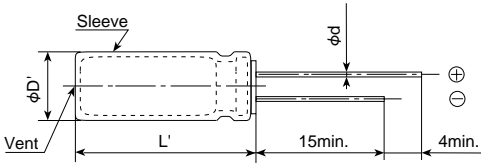

φD	8	10	12.5	16
φd	0.6	0.6	0.6	0.8
F	3.5	5.0	5.0	7.5
φD'	φD+0.5max.			
L'	L+2.0max.			

◆ PART NUMBERING SYSTEM

GXD 25 VB 100 M

Cap tolerance (±20%)
Nominal cap code
Radial lead type
Rated voltage in volts
Series name

Capacitance	Code
0.47μF	R47
1.0μF	1
4.7μF	4R7
10μF	10
100μF	100

◆ STANDARD RATINGS

μF \ V _{dc}	10		16		25		35		50		63			
0.47									8×11.5	12	8×11.5	12		
1.0									8×11.5	17	8×11.5	17		
2.2									8×11.5	26	8×11.5	26		
3.3									8×11.5	32	8×11.5	32		
4.7									8×11.5	38	8×11.5	38		
10									8×11.5	56	8×11.5	56		
22									8×11.5	75	10×12.5	99		
33						8×11.5	92	10×12.5	108	10×16	133	10×16	133	
47					8×11.5	100	10×12.5	129	10×16	142	10×16	159	10×20	173
100	10×12.5	154	10×16	190	10×16	208	10×20	225	12.5×20	279	12.5×20	279		
220	10×16	252	10×20	305	12.5×20	371	12.5×25	403	16×20	459				
330	10×16	308	12.5×20	414	12.5×25	493	16×20	503						
470	10×20	399	12.5×25	537	16×20	601								
1,000	16×20	715												

LBG Series

- For airbag application
- High capacitance, low impedance, and good low temperature behavior
- Endurance with ripple current : 105°C 5000 hours



◆ SPECIFICATIONS

Items	Characteristics			
Category	-55 to +105°C			
Temperature Range	-55 to +105°C			
Rated Voltage Range	16 to 35V _{dc}			
Capacitance Range	820 to 6800µF (at 20°C, 120Hz)			
Capacitance Tolerance	0 to +30% (S) (at 20°C, 120Hz)			
Leakage Current	I=0.01CV Where, I : Max. leakage current (µA), C : Nominal capacitance (µF), V : Rated voltage (V) (at 20°C after 2 minutes)			
Dissipation Factor (tanδ)	Rated voltage (V _{dc})	16V	25V	35V
	tanδ (Max.)	0.16	0.14	0.12
	When nominal capacitance exceeds 1000µF, add 0.02 to the value above for each 1000µF increase. (at 20°C, 120Hz)			
Low Temperature Characteristics (Max. Impedance Ratio)	Rated voltage (V _{dc})	16V	25V	35V
	Z(-55°C)/Z(+20°C)	3	3	3
	Impedance at -10°C and 20°C 100kHz in the STANDARD RATINGS (at 120Hz)			
Endurance	The following specifications shall be satisfied when the capacitors are restored to 20°C after subjected to DC voltage with the rated ripple current is applied for 5000 hours at 105°C.			
	Capacitance change	≤±20% of the initial value		
	DF (tanδ)	≤200% of the initial specified value		
	Leakage current	≤The initial specified value		
Shelf Life	The following specifications shall be satisfied when the capacitors are restored to 20°C after exposing them for 1000 hours at 105°C without voltage applied.			
	Capacitance change	≤±20% of the initial value		
	DF (tanδ)	≤200% of the initial specified value		
	Leakage current	≤The initial specified value		

◆ DIMENSIONS (Radial Lead Type=VB) [mm]

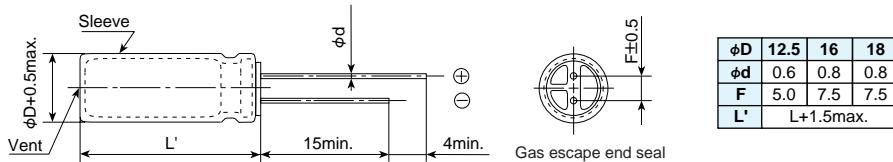

◆ PART NUMBERING SYSTEM

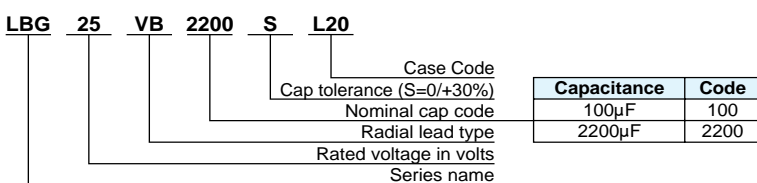

◆ STANDARD RATINGS

φDXL	V _{dc} Case Code	16				25				35			
		Capacitance (µF)	Impedance (Ω _{max} /100kHz)		Rated ripple current (mA _{rms} /105°C, 100kHz)	Capacitance (µF)	Impedance (Ω _{max} /100kHz)		Rated ripple current (mA _{rms} /105°C, 100kHz)	Capacitance (µF)	Impedance (Ω _{max} /100kHz)		Rated ripple current (mA _{rms} /105°C, 100kHz)
			20°C	-10°C			20°C	-10°C			20°C	-10°C	
12.5×20	K20	2,200	0.038	0.076	1,660	1,200	0.038	0.076	1,660	820	0.038	0.076	1,660
12.5×25	K25	2,700	0.030	0.060	1,950	1,800	0.030	0.060	1,950	1,200	0.030	0.060	1,950
16×20	L20	3,300	0.029	0.058	2,210	2,200	0.029	0.058	2,210	1,500	0.029	0.058	2,210
16×25	L25	4,700	0.022	0.044	2,560	3,300	0.022	0.044	2,560	1,800	0.022	0.044	2,560
18×20	M20	4,700	0.028	0.056	2,490	2,700	0.028	0.056	2,490	1,800	0.028	0.056	2,490
18×25	M25	6,800	0.020	0.040	2,740	3,900	0.020	0.040	2,740	2,700	0.020	0.040	2,740

◆ RATED RIPPLE CURRENT MULTIPLIERS

- Frequency Multipliers

Capacitance (µF)	Frequency (Hz)			
	120	1k	10k	100k
820 to 1800	0.60	0.87	0.95	1.00
2200 to 3900	0.75	0.90	0.95	1.00
4700 to 6800	0.85	0.95	0.98	1.00

LLA Series

- Endurance : 85°C 1000 hours
- Solvent-proof, see page 16

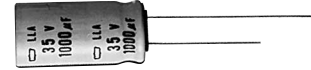

◆SPECIFICATIONS

Items	Characteristics
Category	
Temperature Range	-40 to +85°C
Rated Voltage Range	6.3 to 50V _{dc}
Capacitance Tolerance	±20% (M) (at 20°C, 120Hz)
Leakage Current	I=0.002CV or 0.2µA, whichever is greater. Where, I : Max. leakage current (µA), C : Nominal capacitance (µF), V : Rated voltage (V) (at 20°C after 1 minute)
Dissipation Factor (tanδ)	Rated voltage (V _{dc})
	tanδ (Max.)
Low Temperature Characteristics	When nominal capacitance exceeds 1000µF, add 0.02 to the value above for each 1000µF increase. (at 20°C, 120Hz)
	○Leakage current Leakage current at 85°C : ≤10 times the 20°C specified value ○Max. Impedance Ratio (at 120Hz) Z(-25°C)/Z(+20°C)≤4, Z(-40°C)/Z(+20°C)≤8
Endurance	The following specifications shall be satisfied when the capacitors are restored to 20°C after the rated voltage is applied for 1000 hours at 85°C.
	Capacitance change
	DF (tanδ)
	Leakage current
Shelf Life	The same specifications as "Endurance" shall be satisfied when the capacitors are restored to 20°C after exposing them for 500 hours at 85°C without voltage applied.
Shelf Test	The following specifications shall be satisfied when the capacitors are restored to 20°C after leaving them for 6 months at a nominal temperature (-10 to +40°C) without voltage applied.
	Capacitance change
	DF (tanδ)
	Leakage current

◆DIMENSIONS (Radial Lead Type=VB) [mm]

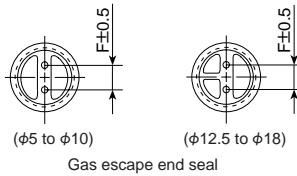
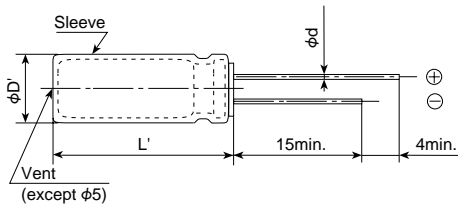

	5	6.3	8	10	12.5	16	18
φD	0.5	0.5	0.6	0.6	0.6	0.8	0.8
F	2.0	2.5	3.5	5.0	5.0	7.5	7.5
φD'	φD+0.5max.						
L'	L+1.5max.						

◆PART NUMBERING SYSTEM

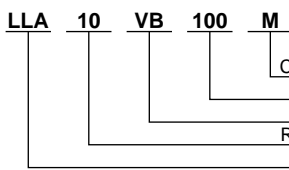

Capacitance	Code
0.1µF	R1
0.47µF	R47
1.0µF	1
4.7µF	4R7
10µF	10
100µF	100

◆STANDARD RATINGS

Items	6.3		10		16		25		35		50	
	Case size	Rated ripple	Case size	Rated ripple	Case size	Rated ripple	Case size	Rated ripple	Case size	Rated ripple	Case size	Rated ripple
µF	φDXL (mm)	(mArms/85°C/120Hz)	φDXL (mm)	(mArms/85°C/120Hz)	φDXL (mm)	(mArms/85°C/120Hz)	φDXL (mm)	(mArms/85°C/120Hz)	φDXL (mm)	(mArms/85°C/120Hz)	φDXL (mm)	(mArms/85°C/120Hz)
1.0												
2.2												
3.3												
4.7												
10					5×11	44	5×11	31	5×11	40	5×11	42
22			5×11	59	5×11	75	5×11	80	5×11	87	5×11	95
33	5×11	55	5×11	84	5×11	90	5×11	97	5×11	105	6.3×11	125
47	5×11	79	5×11	100	5×11	110	5×11	115	6.3×11	145	6.3×11	150
100	5×11	130	5×11	145	6.3×11	180	6.3×11	190	8×11.5	240	8×11.5	255
220	6.3×11	230	6.3×11	250	8×11.5	300	8×11.5	320	10×12.5	420	10×16	490
330	6.3×11	280	8×11.5	350	8×11.5	370	10×12.5	470	10×16	570	10×20	650
470	8×11.5	380	8×11.5	415	10×12.5	520	10×16	620	10×20	740	12.5×20	860
1,000	10×12.5	650	10×16	790	10×20	910	12.5×20	1,090	12.5×25	1,300	16×25	1,530
2,200	12.5×20	1,150	12.5×20	1,240	12.5×25	1,420	16×25	1,660	16×31.5	1,890	18×35.5	2,160
3,300	12.5×20	1,380	12.5×25	1,590	16×25	1,840	16×31.5	2,070	18×35.5	2,340		
4,700	16×25	1,880	16×25	1,980	16×31.5	2,260	18×35.5	2,520	18×40	2,690		
6,800	16×25	2,120	16×31.5	2,390	18×35.5	2,690	18×40	2,830				
10,000	16×31.5	2,500	18×35.5	2,840	18×40	2,920						
15,000	18×35.5	2,990										

Items	50	
	Case size	Rated ripple
µF	φDXL (mm)	(mArms/85°C/120Hz)
0.1	5×11	1.3
0.22	5×11	2.9
0.33	5×11	4.4
0.47	5×11	11



◆SPECIFICATIONS

Items	Characteristics
Category	
Temperature Range	-20 to +55°C
Rated Voltage Range	300 & 330V _{dc}
Capacitance Tolerance	-10 to +20% (V) (at 20°C, 120Hz)
Leakage Current	I=1×C Where, I : Max. leakage current (µA), C : Nominal capacitance (µF) (at 20°C after 5 minutes)
Dissipation Factor (tanδ)	0.06max. (at 20°C, 120Hz)
Charge and Discharge Characteristics	The following specifications shall be satisfied when the capacitors are restored to 20°C after charge and discharge are repeated 5000 times at room temperature (5 to 35°C). Discharge resistance or Xenon tube : 0.7 to 1.0Ω.
	Capacitance change ≤±10% of the initial value
	DF (tanδ) ≤150% of the initial specified value
	Leakage current ≤150% of the initial specified value
Shelf Life	The following specifications shall be satisfied when the capacitors are restored to 20°C after exposing them for 1000 hours at 55°C without voltage applied.
	Capacitance change ≤±10% of the initial value
	DF (tanδ) ≤150% of the initial specified value
	Leakage current ≤150% of the initial specified value

◆DIMENSIONS (Radial Lead Type=VB) [mm]

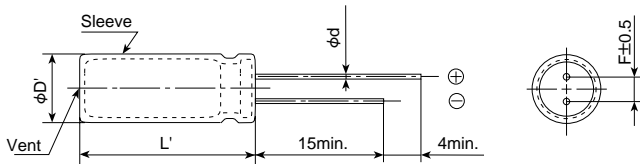

φD	10	12.5	14.5	16	18
φd	0.6	0.6	0.8	0.8	0.8
F	5.0	5.0	7.5	7.5	7.5
φD'	φD+0.5max.				
L'	L+1.0max.				

◆PART NUMBERING SYSTEM

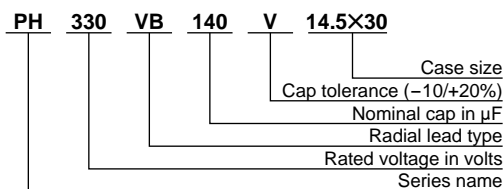

◆STANDARD RATINGS

Case size φD×L (mm)

µF	V _{dc}	300V					330V						
		10×26	12.5×23	14.5×23	16×24	18×24	10×27	12.5×24	14.5×24	16×26	18×24		
50		10×26					10×27						
70		10×33	12.5×23				10×35	12.5×24					
100		10×43	12.5×28	14.5×23				12.5×30	14.5×24				
120			12.5×32	14.5×26	16×24			12.5×34	14.5×27	16×26			
140			12.5×36	14.5×28	16×27			12.5×39	14.5×30	16×28	18×24		
160			12.5×40	14.5×31	16×28	18×24		12.5×43	14.5×33	16×30	18×26		
180			12.5×44	14.5×34	16×30	18×26			14.5×36	16×33	18×28		
200				14.5×37	16×33	18×28			14.5×39	16×35	18×29		
220				14.5×39	16×35	18×29			14.5×43	16×38	18×31		
240				14.5×42	16×37	18×31				16×40	18×33		

Custom-made products are available upon requests. Please contact our local office or representative.

New!

SMQ Series

- Downsized from current downsized snap-ins SMM series
- Endurance with ripple current : 85°C 2000 hours
- Non solvent-proof type

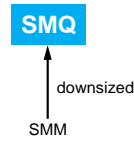

◆ SPECIFICATIONS

Items	Characteristics			
Category	-25 to +85°C			
Temperature Range	-25 to +85°C			
Rated Voltage Range	160 to 450V _{dc}			
Capacitance Tolerance	±20% (M) (at 20°C, 120Hz)			
Leakage Current	I ≤ 3√CV Where, I : Max. leakage current (µA), C : Nominal capacitance (µF), V : Rated voltage (V) (at 20°C after 5 minutes)			
Dissipation Factor (tanδ)	Rated voltage (V _{dc})	160 to 250V	315 to 400V	450V
	tanδ (Max.)	0.15	0.15	0.20
Low Temperature Characteristics (Max. Impedance Ratio)	Rated voltage (V _{dc})	160 to 250V	315 to 400V	450V
	Z(-25°C)/Z(+20°C)	4	8	8
Endurance	The following specifications shall be satisfied when the capacitors are restored to 20°C after subjected to DC voltage with the rated ripple current is applied for 2000 hours at 85°C.			
	Capacitance change	≤ ±20% of the initial value		
	DF (tanδ)	≤ 200% of the initial specified value		
	Leakage current	≤ The initial specified value		
Shelf Life	The following specifications shall be satisfied when the capacitors are restored to 20°C after exposing them for 1000 hours at 85°C without voltage applied.			
	Capacitance change	≤ ±15% of the initial value		
	DF (tanδ)	≤ 150% of the initial specified value		
	Leakage current	≤ The initial specified value		

◆ DIMENSIONS [mm]

● Standard Terminal Type : VSSN (φ22 to φ35)

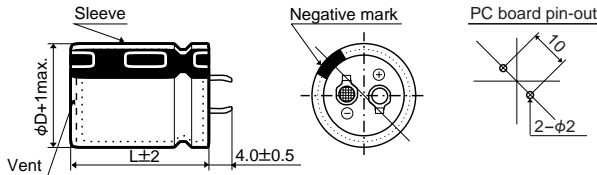

● Terminal Type : LISN (φ35)

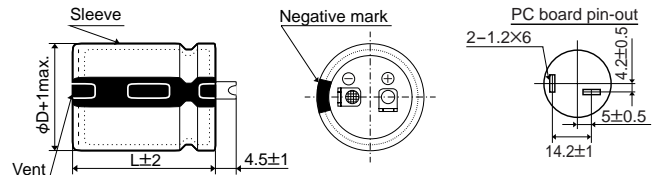

◆ PART NUMBERING SYSTEM

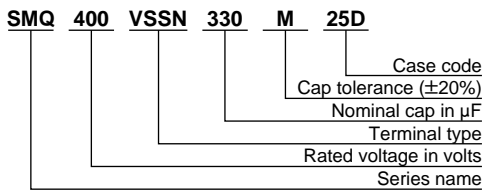

◆ CASE CODE [mm]

Case code	Case size φD×L	Case code	Case size φD×L	Case code	Case size φD×L	Case code	Case size φD×L
22A	22×25	25A	25.4×25	30A	30×25	35A	35×25
22B	22×30	25B	25.4×30	30B	30×30	35B	35×30
22C	22×35	25C	25.4×35	30C	30×35	35C	35×35
22D	22×40	25D	25.4×40	30D	30×40	35D	35×40
22E	22×45	25E	25.4×45	30E	30×45	35E	35×45
22F	22×50	25F	25.4×50	30F	30×50	35F	35×50

New!

SMQ Series

◆STANDARD RATINGS

μF	V _{dc} φD	160				180				200			
		22	25	30	35	22	25	30	35	22	25	30	35
390										22×25 1.68			
470					22×25 2.08					22×30 1.85			
560	22×25 2.25				22×30 2.25					22×30 2.43	25.4×25 2.43		
680	22×30 2.50				22×30 2.50	25.4×25 2.50				22×35 2.68	25.4×30 2.68		
820	22×35 2.75				22×35 2.75	25.4×30 2.75				22×40 2.93	25.4×30 2.93	30×25 2.93	
1,000	22×40 3.00	25.4×30 3.00			22×45 3.00	25.4×35 3.00	30×25 3.00			22×45 3.25	25.4×35 3.25	30×30 3.25	35×25 3.25
1,200	22×45 3.25	25.4×35 3.25	30×25 3.25		22×50 3.31	25.4×40 3.31	30×30 3.31	35×25 3.31			25.4×40 3.50	30×30 3.50	35×30 3.50
1,500	22×50 3.73	25.4×40 3.73	30×30 3.73	35×25 3.73		25.4×45 3.83	30×35 3.83	35×30 3.83			25.4×50 3.87	30×35 3.87	35×30 3.87
1,800		25.4×45 4.20	30×35 4.20	35×30 4.20		25.4×50 4.32	30×40 4.32	35×30 4.32				30×45 4.32	35×35 4.32
2,200			30×40 4.78	35×35 4.78			30×45 4.92	35×40 4.92				30×50 4.92	35×40 4.92
2,700				35×40 5.45				35×45 5.52					35×50 5.45
3,300				35×45 5.75				35×50 5.75					
3,900				35×50 6.00	← Upper : Case size φDXL (mm) ← Lower : Rated ripple current (Arms) at 85°C, 120Hz								

μF	V _{dc} φD	250				315				350			
		22	25	30	35	22	25	30	35	22	25	30	35
150										22×25 1.12			
180					22×25 1.21					22×30 1.22			
220					22×30 1.41					22×35 1.44			
270	22×25 1.31				22×30 1.60					22×40 1.66	25.4×30 1.66		
330	22×30 1.75				22×40 1.82	25.4×30 1.82	30×25 1.82			22×45 1.88	25.4×35 1.88		
390	22×30 1.91	25.4×25 1.91			22×45 2.01	25.4×35 2.01	30×30 2.01			22×50 2.06	25.4×40 2.06	30×30 2.06	35×25 2.06
470	22×35 2.11	25.4×30 2.11			22×50 2.27	25.4×40 2.27	30×30 2.27	35×25 2.27			25.4×45 2.40	30×35 2.40	35×30 2.40
560	22×40 2.25	25.4×30 2.25	30×25 2.25			25.4×45 2.56	30×35 2.56	35×30 2.56			25.4×50 2.60	30×40 2.60	35×30 2.60
680	22×45 2.50	25.4×35 2.50	30×30 2.50				30×40 2.87	35×35 2.87				30×45 2.96	35×35 2.96
820	22×50 2.77	25.4×40 2.77	30×30 2.77	35×25 2.77			30×45 3.25	35×40 3.25				30×50 3.25	35×45 3.25
1,000		25.4×45 3.32	30×35 3.32	35×30 3.32			30×50 3.63	35×45 3.63					35×50 3.54
1,200			30×40 3.53	35×35 3.53									
1,500			30×50 4.04	35×40 4.04									
1,800				35×45 4.55	← Upper : Case size φDXL (mm) ← Lower : Rated ripple current (Arms) at 85°C, 120Hz								

◆STANDARD RATINGS

μF	V _{dc}		400				450			
	φ	D	22	25	30	35	22	25	30	35
82							22×25 0.83			
100							22×25 0.93			
120		22×25 1.02					22×30 1.04			
150		22×30 1.16					22×35 1.19	25.4×25 1.19		
180		22×35 1.44					22×40 1.35	25.4×30 1.35		
220		22×40 1.49	25.4×30 1.49				22×45 1.55	25.4×40 1.55	30×30 1.55	35×25 1.55
270		22×45 1.67	25.4×35 1.67	30×25 1.67			22×50 1.78	25.4×40 1.78	30×30 1.78	
330		22×50 1.90	25.4×40 1.90	30×30 1.90	35×25 1.90			25.4×50 2.01	30×40 2.01	35×30 2.01
390			25.4×45 2.13	30×35 2.13	35×30 2.13				30×40 2.24	35×35 2.24
470			25.4×50 2.39	30×40 2.39	35×30 2.39				30×45 2.53	35×40 2.53
560				30×45 2.69	35×35 2.69				30×50 2.82	35×45 2.82
680				30×50 2.96	35×40 2.96					
820						35×45 3.25	← Upper : Case size φDXL (mm) ← Lower : Rated ripple current (Arms) at 85°C, 120Hz			

◆RATED RIPPLE CURRENT MULTIPLIERS

●Frequency Multipliers

Frequency(Hz)	50	120	300	1k	10k	50k
160 to 250V _{dc}	0.81	1.00	1.17	1.32	1.45	1.50
315 to 450V _{dc}	0.77	1.00	1.16	1.30	1.41	1.43

New!

KMQ Series

- Downsized from current downsized snap-ins KMM series
- Endurance with ripple current : 105°C 2000 hours
- Non solvent-proof type

KMQ

↑ downsized

KMM



◆ SPECIFICATIONS

Items	Characteristics			
Category	-25 to +105°C			
Temperature Range				
Rated Voltage Range	160 to 450V _{dc}			
Capacitance Tolerance	±20% (M) (at 20°C, 120Hz)			
Leakage Current	I ≤ 3√CV Where, I : Max. leakage current (µA), C : Nominal capacitance (µF), V : Rated voltage (V) (at 20°C after 5 minutes)			
Dissipation Factor (tanδ)	Rated voltage (V _{dc})	160 to 250V	315 to 400V	450V
	tanδ (Max.)	0.15	0.15	0.20
Low Temperature Characteristics (Max. Impedance Ratio)	Rated voltage (V _{dc})	160 to 250V	315 to 400V	450V
	Z(-25°C)/Z(+20°C)	4	8	8
Endurance	The following specifications shall be satisfied when the capacitors are restored to 20°C after subjected to DC voltage with the rated ripple current is applied for 2000 hours at 105°C.			
	Capacitance change	≤ ±20% of the initial value		
	DF (tanδ)	≤ 200% of the initial specified value		
	Leakage current	≤ The initial specified value		
Shelf Life	The following specifications shall be satisfied when the capacitors are restored to 20°C after exposing them for 1000 hours at 105°C without voltage applied.			
	Capacitance change	≤ ±15% of the initial value		
	DF (tanδ)	≤ 150% of the initial specified value		
	Leakage current	≤ The initial specified value		

◆ DIMENSIONS [mm]

- Standard Terminal Type : VSSN (φ22 to φ35)

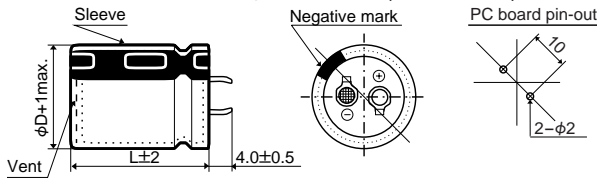

- Terminal Type : LISN (φ35)

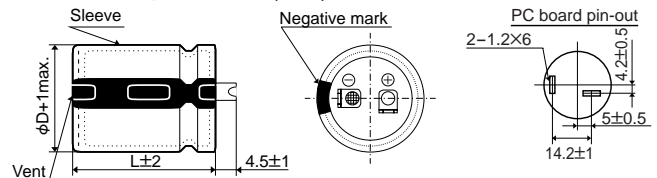

◆ PART NUMBERING SYSTEM

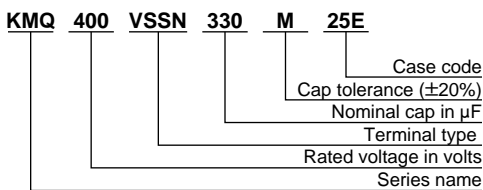

◆ CASE CODE [mm]

Case code	Case size φD×L	Case code	Case size φD×L	Case code	Case size φD×L	Case code	Case size φD×L
22A	22×25	25A	25.4×25	30A	30×25	35A	35×25
22B	22×30	25B	25.4×30	30B	30×30	35B	35×30
22C	22×35	25C	25.4×35	30C	30×35	35C	35×35
22D	22×40	25D	25.4×40	30D	30×40	35D	35×40
22E	22×45	25E	25.4×45	30E	30×45	35E	35×45
22F	22×50	25F	25.4×50	30F	30×50	35F	35×50

◆STANDARD RATINGS

μF	V _{dc} φD	160				180				200			
		22	25	30	35	22	25	30	35	22	25	30	35
390						22×25 1.30				22×25 1.31			
470		22×25 1.40				22×30 1.40				22×30 1.45			
560		22×30 1.50				22×30 1.50	25.4×25 1.50			22×30 1.67	25.4×25 1.67		
680		22×30 1.70	25.4×25 1.70			22×35 1.70	25.4×30 1.70			22×40 1.75	25.4×30 1.75		
820		22×35 2.00	25.4×30 2.00	30×25 2.00		22×40 2.00	25.4×30 2.00	30×25 2.00		22×45 2.04	25.4×35 2.04	30×25 2.04	
1,000		22×40 2.20	25.4×35 2.20	30×25 2.20		22×45 2.20	25.4×40 2.20	30×30 2.20	35×25 2.20	22×50 2.30	25.4×45 2.30	30×30 2.30	35×25 2.30
1,200			25.4×40 2.30	30×30 2.30	35×25 2.30		25.4×45 2.30	30×35 2.30	35×30 2.30		25.4×50 2.65	30×35 2.65	35×30 2.65
1,500			25.4×45 2.50	30×35 2.50	35×30 2.50		25.4×50 2.50	30×40 2.50	35×30 2.50			30×40 2.80	35×30 2.80
1,800			25.4×50 2.70	30×40 2.70	35×30 2.70			30×45 2.70	35×35 2.70			30×45 3.08	35×40 3.08
2,200				30×45 2.90	35×35 2.90			30×50 2.90	35×40 2.90				35×45 3.48
2,700				30×50 3.10	35×40 3.10				35×50 3.10				
3,300					35×50 3.30	← Upper : Case size φD×L (mm) ← Lower : Rated ripple current (Arms) at 105°C, 120Hz							

μF	V _{dc} φD	250				315				350			
		22	25	30	35	22	25	30	35	22	25	30	35
120										22×25 0.75			
150						22×25 0.82				22×30 0.82			
180						22×30 0.90				22×30 0.90	25.4×25 0.90		
220		22×25 1.00				22×30 1.00	25.4×25 1.00			22×35 1.00	25.4×30 1.00		
270		22×25 1.10				22×35 1.10	25.4×30 1.10			22×40 1.10	25.4×30 1.10	30×25 1.10	
330		22×30 1.20	25.4×25 1.20			22×45 1.20	25.4×35 1.20	30×25 1.20		22×45 1.20	25.4×40 1.20	30×30 1.20	
390		22×35 1.30	25.4×25 1.30			22×45 1.30	25.4×40 1.30	30×30 1.30	35×25 1.30		25.4×45 1.30	30×35 1.30	
470		22×40 1.40	25.4×30 1.40	30×25 1.40			25.4×45 1.40	30×35 1.40	35×25 1.40		25.4×50 1.40	30×35 1.40	35×30 1.40
560		22×45 1.50	25.4×35 1.50	30×25 1.50			25.4×50 1.50	30×40 1.50	35×30 1.50			30×45 1.50	35×35 1.50
680		22×50 1.70	25.4×40 1.70	30×30 1.70	35×25 1.70			30×45 1.70	35×35 1.70			30×50 1.70	35×40 1.70
820			25.4×45 2.00	30×35 2.00	35×30 2.00			30×50 2.00	35×40 2.00				35×45 1.90
1,000				30×40 2.20	35×30 2.20				35×45 2.30				
1,200				30×45 2.30	35×35 2.30								
1,500					35×45 2.50								
1,800					35×50 2.70	← Upper : Case size φD×L (mm) ← Lower : Rated ripple current (Arms) at 105°C, 120Hz							



New!

KMQ Series

◆STANDARD RATINGS

μF	V _{dc} φD	400				450			
		22	25	30	35	22	25	30	35
68						22×25 0.50			
82						22×30 0.56			
100		22×25 0.70				22×30 0.64	25.4×25 0.64		
120		22×30 0.75				22×35 0.72	25.4×30 0.72		
150		22×30 0.88	25.4×25 0.88			22×40 0.79	25.4×30 0.79	30×25 0.79	
180		22×35 0.95	25.4×30 0.95			22×45 0.87	25.4×40 0.87	30×30 0.87	
220		22×45 1.10	25.4×35 1.10	30×25 1.10			25.4×45 1.00	30×30 1.00	35×25 1.00
270		22×50 1.22	25.4×40 1.22	30×30 1.22	35×25 1.22		25.4×50 1.19	30×40 1.19	35×30 1.19
330			25.4×45 1.44	30×35 1.44	35×30 1.44			30×45 1.38	35×35 1.38
390			25.4×50 1.55	30×40 1.55	35×30 1.55			30×50 1.55	35×40 1.55
470				30×45 1.68	35×35 1.68				35×45 1.74
560				30×50 1.90	35×40 1.90				35×50 1.90
680					35×45 2.12	← Upper : Case size φD×L (mm) ← Lower : Rated ripple current (Arms) at 105°C, 120Hz			

◆RATED RIPPLE CURRENT MULTIPLIERS

●Frequency Multipliers

Frequency(Hz)	50	120	300	1k	10k	50k
160 to 250V _{dc}	0.81	1.00	1.17	1.32	1.45	1.50
315 to 450V _{dc}	0.77	1.00	1.16	1.30	1.41	1.43

SMM Series

- Downsize, longer life, and high ripple version of SMH series
- Endurance with ripple current : 85°C 3000 hours
- Non solvent-proof type

SMM
↑ downsized
longer life
higher ripple
SMH



◆ SPECIFICATIONS

Items	Characteristics		
Category	-25 to +85°C		
Temperature Range	-25 to +85°C		
Rated Voltage Range	160 to 450V _{dc}		
Capacitance Tolerance	±20% (M) (at 20°C, 120Hz)		
Leakage Current	$I \leq 3\sqrt{CV}$ Where, I : Max. leakage current (µA), C : Nominal capacitance (µF), V : Rated voltage (V) (at 20°C after 5 minutes)		
Dissipation Factor (tanδ)	Rated voltage (V _{dc})	160 to 400V	420 & 450V
	tanδ (Max.)	0.15	0.20
		(at 20°C, 120Hz)	
Low Temperature Characteristics (Max. Impedance Ratio)	Rated voltage (V _{dc})	160 to 400V	420 & 450V
	Z(-25°C)/Z(+20°C)	4	8
		(at 120Hz)	
Endurance	The following specifications shall be satisfied when the capacitors are restored to 20°C after subjected to DC voltage with the rated ripple current is applied for 3000 hours at 85°C.		
	Capacitance change	≤±20% of the initial value	
	DF (tanδ)	≤200% of the initial specified value	
	Leakage current	≤The initial specified value	
Shelf Life	The following specifications shall be satisfied when the capacitors are restored to 20°C after exposing them for 1000 hours at 85°C without voltage applied.		
	Capacitance change	≤±15% of the initial value	
	DF (tanδ)	≤150% of the initial specified value	
	Leakage current	≤The initial specified value	

◆ DIMENSIONS [mm]

● Standard Terminal Type : VSSN (φ20 to φ35)

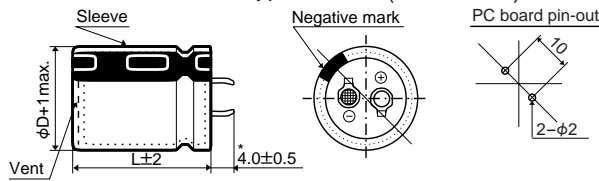

● Terminal Type : LISN (φ35)

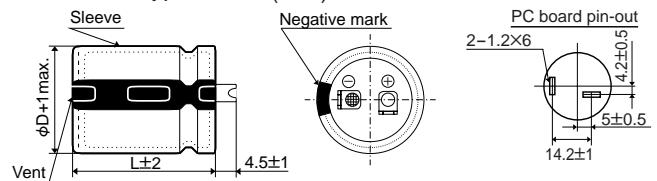

*φD=35mm : 3.5±0.5mm

● Terminal type : LCSN (φ20×30 to 50L & φ22×30 to 50L)

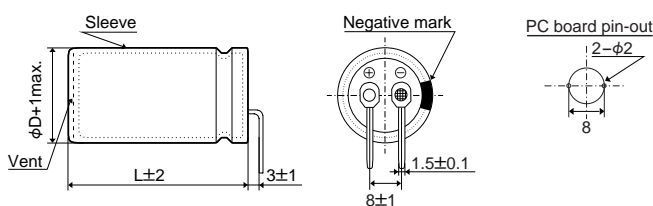

◆ PART NUMBERING SYSTEM

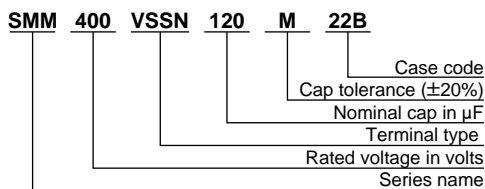

◆ CASE CODE [mm]

Case code	Case size φDXL	Case code	Case size φDXL	Case code	Case size φDXL	Case code	Case size φDXL	Case code	Case size φDXL
—	—	22S	22×20	25S	25.4×20	30S	30×20	35S	35×20
20A	20×25	22A	22×25	25A	25.4×25	30A	30×25	35A	35×25
20B	20×30	22B	22×30	25B	25.4×30	30B	30×30	35B	35×30
20C	20×35	22C	22×35	25C	25.4×35	30C	30×35	35C	35×35
20D	20×40	22D	22×40	25D	25.4×40	30D	30×40	35D	35×40
20E	20×45	22E	22×45	25E	25.4×45	30E	30×45	35E	35×45
20F	20×50	22F	22×50	25F	25.4×50	30F	30×50	35F	35×50

SMM Series

◆STANDARD RATINGS

μF	V _{dc}		160					180				
	φD		20	22	25.4	30	35	20	22	25.4	30	35
220								22×20 1.18				
270	20×25 1.28	22×20 1.30						20×25 1.29				
330	20×25 1.55							20×30 1.77	22×25 1.77	25.4×20 1.49		
390	20×30 1.63	22×25 1.63	25.4×20 1.62					20×30 1.84	22×25 1.84			
470	20×30 1.90	22×30 1.86	25.4×25 1.86					20×35 1.91	22×30 1.91	25.4×25 2.08	30×20 1.88	
560	20×35 2.14	22×30 2.15	25.4×25 2.15	30×20 2.05				20×40 2.15	22×35 2.25	25.4×25 2.25		
680	20×40 2.35	22×35 2.35	25.4×30 2.33	30×25 2.33	35×20 2.26			20×45 2.41	22×35 2.48	25.4×30 2.50	30×25 2.46	35×20 2.26
820	20×45 2.64	22×40 2.68	25.4×30 2.65	30×25 2.64	35×20 2.49			20×50 2.72	22×40 2.86	25.4×35 2.75	30×25 2.69	
1,000		22×45 3.02	25.4×35 3.00	30×30 2.96	35×25 3.13				22×50 3.10	25.4×40 3.06	30×30 3.10	35×25 2.98
1,200		22×50 3.47	25.4×40 3.43	30×30 3.41	35×25 3.40					25.4×45 3.63	30×35 3.55	35×30 3.49
1,500			25.4×50 3.96	30×35 3.96	35×30 3.94						30×40 4.10	35×35 4.02
1,800				30×40 4.31	35×35 4.28						30×45 4.55	35×35 4.54
2,200				30×50 4.96	35×40 4.96							35×40 4.83
2,700					35×45 5.57							35×50 5.30
3,300					35×50 6.21							

← Upper : Case size φD×L (mm)
 ← Lower : Rated ripple current (Arms) at 85°C, 120Hz

◆RATED RIPPLE CURRENT MULTIPLIERS

●Frequency Multipliers

Frequency(Hz)	50	120	300	1k	10k	50k
160 to 250V _{dc}	0.81	1.00	1.17	1.32	1.45	1.50
315 to 450V _{dc}	0.77	1.00	1.16	1.30	1.41	1.43

SMM Series

◆STANDARD RATINGS

μF	V _{dc}		200					220				
	φD		20	22	25.4	30	35	20	22	25.4	30	35
180									22×20 1.06			
220			20×25 1.19	22×20 1.18				20×25 1.25				
270			20×25 1.39	22×25 1.37	25.4×20 1.35			20×30 1.46	22×25 1.47	25.4×20 1.35		
330			20×30 1.56	22×25 1.51	25.4×20 1.49			20×35 1.64	22×30 1.70	25.4×25 1.69	30×20 1.58	
390			20×35 1.74	22×30 1.73	25.4×25 1.71	30×20 1.71		20×35 1.84	22×30 1.89	25.4×25 1.84	30×20 1.71	
470			20×35 2.03	22×30 1.97	25.4×25 1.95	30×20 1.88		20×40 2.12	22×35 2.08	25.4×30 2.08	30×25 2.12	35×20 1.88
560			20×40 2.18	22×35 2.18	25.4×30 2.15	30×25 2.15	35×20 2.05	20×50 2.33	22×40 2.33	25.4×35 2.38	30×25 2.31	35×20 2.14
680			20×50 2.48	22×40 2.48	25.4×30 2.48	30×25 2.48			22×45 2.63	25.4×35 2.68	30×30 2.62	35×25 2.58
820				22×45 2.81	25.4×35 2.79	30×30 2.80	35×25 2.83			25.4×45 3.01	30×35 2.99	35×30 2.79
1,000				22×50 3.28	25.4×40 3.28	30×35 3.15	35×30 3.26			25.4×50 3.40	30×35 3.42	35×30 3.29
1,200					25.4×45 3.61	30×35 3.61	35×30 3.57				30×40 3.88	35×35 3.68
1,500						30×45 4.13	35×35 4.06				30×50 4.44	35×40 4.10
1,800						30×50 4.60	35×40 4.59	← Upper : Case size φD×L (mm) ← Lower : Rated ripple current (Arms) at 85°C, 120Hz				35×45 4.52
2,200							35×45 5.25					

μF	V _{dc}		250					315				
	φD		20	22	25.4	30	35	20	22	25.4	30	35
100									22×20 0.79			
120								20×25 0.89		25.4×20 0.90		
150				22×20 0.97				20×30 1.05	22×25 1.06	25.4×20 1.00		
180			20×25 1.20	22×20 1.06				20×35 1.18	22×30 1.29	25.4×25 1.38	30×20 1.16	
220			20×25 1.26	22×25 1.24	25.4×20 1.22			20×35 1.30	22×30 1.41	25.4×25 1.47	30×20 1.28	
270			20×30 1.42	22×25 1.50				20×45 1.52	22×35 1.68	25.4×30 1.70	30×25 1.55	35×20 1.43
330			20×35 1.68	22×30 1.66	25.4×25 1.61	30×20 1.58		20×50 1.73	22×40 1.91	25.4×35 1.94	30×25 1.98	
390			20×40 1.92	22×35 1.88	25.4×30 1.88	30×25 1.86	35×20 1.71		22×45 2.07	25.4×40 2.11	30×30 2.15	35×25 1.95
470			20×50 2.06	22×35 2.15	25.4×35 2.15	30×25 2.05	35×20 1.88			25.4×45 2.31	30×35 2.38	35×30 2.46
560				22×40 2.48	25.4×35 2.35	30×25 2.35				25.4×50 2.46	30×35 2.63	35×30 2.69
680				22×50 2.61	25.4×40 2.67	30×30 2.71	35×25 2.58				30×45 2.82	35×35 3.05
820					25.4×45 3.01	30×35 2.98	35×30 2.96				30×50 3.28	35×40 3.45
1,000						30×40 3.56	35×35 3.48					35×45 3.59
1,200						30×45 3.99	35×35 3.84					
1,500							35×40 4.33	← Upper : Case size φD×L (mm) ← Lower : Rated ripple current (Arms) at 85°C, 120Hz				
1,800							35×50 4.54					

◆STANDARD RATINGS

μF	V _{dc} φD	350					400				
		20	22	25.4	30	35	20	22	25.4	30	35
68							20×25 0.75	22×20 0.65			
82			22×20 0.72				20×25 0.82	22×25 0.84	25.4×20 0.74		
100		20×25 0.81					20×30 0.95	22×25 0.99	25.4×20 0.82		
120		20×30 0.96	22×25 1.04	25.4×20 0.90			20×35 1.07	22×30 1.09	25.4×25 1.13	30×20 0.95	
150		20×30 1.10	22×30 1.20	25.4×25 1.22	30×20 1.06		20×40 1.22	22×35 1.24	25.4×30 1.27	30×25 1.20	
180		20×35 1.24	22×30 1.34	25.4×25 1.37	30×20 1.16		20×45 1.28	22×40 1.41	25.4×30 1.44	30×25 1.52	35×20 1.16
220		20×45 1.37	22×35 1.47	25.4×30 1.53	30×25 1.54	35×20 1.29	20×50 1.41	22×45 1.58	25.4×35 1.64	30×30 1.66	35×25 1.47
270		20×50 1.56	22×40 1.70	25.4×35 1.73	30×25 1.80	35×20 1.49		22×50 1.65	25.4×40 1.79	30×30 1.82	35×25 1.63
330			22×45 1.87	25.4×35 1.97	30×30 2.03	35×25 1.80			25.4×45 2.00	30×35 2.05	35×30 2.05
390				25.4×40 2.14	30×35 2.23	35×30 2.30			25.4×50 2.12	30×40 2.26	35×35 2.28
470				25.4×50 2.55	30×35 2.53	35×30 2.55				30×45 2.51	35×35 2.54
560					30×40 2.73	35×35 2.75				30×50 2.85	35×40 2.85
680					30×50 3.15	35×40 3.15					35×50 3.10
820						35×45 3.47	← Upper : Case size φD×L (mm) ← Lower : Rated ripple current (Arms) at 85°C, 120Hz				
1,000						35×50 3.60					

μF	V _{dc} φD	420					450				
		20	22	25.4	30	35	20	22	25.4	30	35
47			22×20 0.54					22×20 0.54			
56		20×25 0.58	22×20 0.59				20×25 0.61	22×20 0.59			
68		20×25 0.70		25.4×20 0.68			20×30 0.71	22×25 0.71	25.4×20 0.68		
82		20×30 0.80	22×25 0.85	25.4×20 0.74			20×35 0.80	22×25 0.86	25.4×20 0.74	30×20 0.79	
100		20×35 0.90	22×30 0.97	25.4×25 0.98	30×20 0.87		20×35 0.88	22×30 0.95	25.4×25 0.97	30×20 0.87	
120		20×35 1.04	22×30 1.07	25.4×25 1.08	30×20 0.95		20×40 0.99	22×35 1.07	25.4×30 1.09	30×25 1.12	35×20 0.99
150		20×40 1.17	22×35 1.21	25.4×30 1.26	30×25 1.30	35×20 1.11	20×45 1.13	22×40 1.18	25.4×30 1.25	30×25 1.29	35×20 1.06
180		20×50 1.27	22×40 1.33	25.4×35 1.42	30×25 1.48	35×20 1.16		22×45 1.32	25.4×35 1.40	30×30 1.45	35×25 1.33
220			22×45 1.55	25.4×35 1.58	30×30 1.65	35×25 1.47		22×50 1.48	25.4×40 1.59	30×30 1.64	35×25 1.66
270				25.4×40 1.74	30×35 1.90	35×30 1.94			25.4×45 1.73	30×35 1.89	35×30 1.90
330				25.4×50 2.20	30×35 1.98	35×35 2.17			25.4×50 2.12	30×40 2.12	35×35 2.15
390					30×40 2.22	35×35 2.27				30×45 2.35	35×40 2.38
470					30×45 2.50	35×40 2.61				30×50 2.65	35×45 2.68
560						35×45 2.95	← Upper : Case size φD×L (mm) ← Lower : Rated ripple current (Arms) at 85°C, 120Hz				35×50 2.88
680						35×50 3.15					

KMM Series

- Downsize, longer life, and high ripple version of KMH series
- Endurance with ripple current : 105°C 2000 to 3000 hours
- Non solvent-proof type

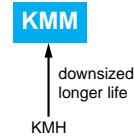

◆SPECIFICATIONS

Items	Characteristics		
Category	-25 to +105°C		
Temperature Range	-25 to +105°C		
Rated Voltage Range	160 to 450V _{dc}		
Capacitance Tolerance	±20% (M) (at 20°C, 120Hz)		
Leakage Current	$I \leq 3\sqrt{CV}$ Where, I : Max. leakage current (µA), C : Nominal capacitance (µF), V : Rated voltage (V) (at 20°C after 5 minutes)		
Dissipation Factor (tanδ)	Rated voltage (V _{dc})	160 to 400V	420 & 450V
	tanδ (Max.)	0.15	0.20
Low Temperature Characteristics (Max. Impedance Ratio)	Rated voltage (V _{dc})	160 to 400V	420 & 450V
	Z(-25°C)/Z(+20°C)	4	8
Endurance	The following specifications shall be satisfied when the capacitors are restored to 20°C after subjected to DC voltage with the rated ripple current is applied for 3000 hours (2000 hours for φ20mm products) at 105°C.		
	Capacitance change	≤±20% of the initial value	
	DF (tanδ)	≤200% of the initial specified value	
	Leakage current	≤The initial specified value	
Shelf Life	The following specifications shall be satisfied when the capacitors are restored to 20°C after exposing them for 1000 hours at 105°C without voltage applied.		
	Capacitance change	≤±15% of the initial value	
	DF (tanδ)	≤150% of the initial specified value	
	Leakage current	≤The initial specified value	

◆DIMENSIONS [mm]

- Standard Terminal Type : VSSN (φ20 to φ35)

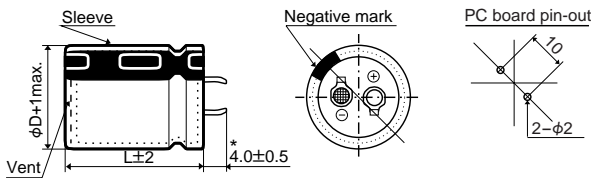

*φD=35mm : 3.5±0.5mm

- Terminal Type : VNSN (φ22 to φ35)

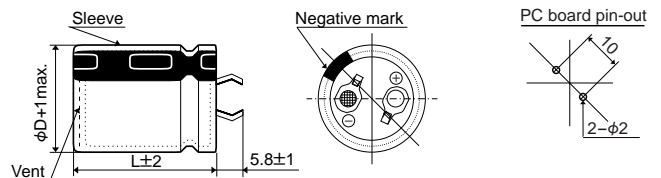

- Terminal Type : LISN (φ35)

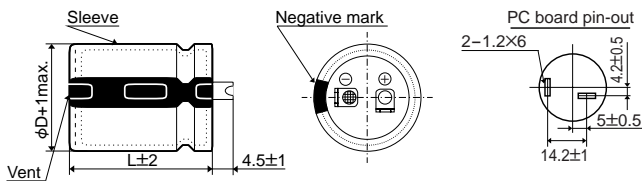

- Terminal Type : LCSN (φ20×30 to 50L, φ22×30 to 50L)

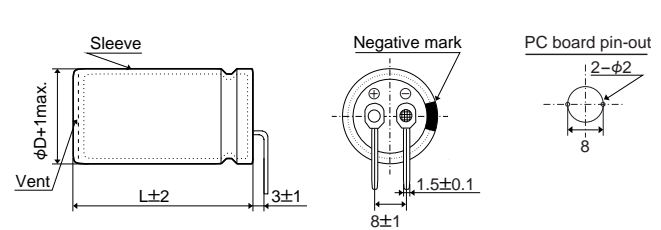

◆PART NUMBERING SYSTEM

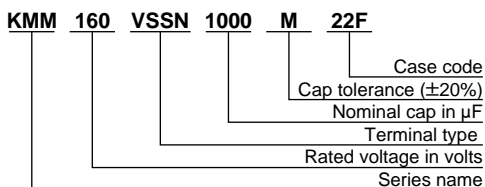

◆STANDARD RATINGS

μF	V _{dc}		160					180				
	φD		20	22	25.4	30	35	20	22	25.4	30	35
150								20×20 0.62				
180	20×20 0.68							20×25 0.77	22×20 0.80			
220	20×25 0.85	22×20 0.81						20×25 1.00		25.4×20 0.90		
270	20×25 1.10		25.4×20 0.98					20×30 1.10	22×25 1.00	25.4×20 0.95		
330	20×30 1.20	22×25 1.20	25.4×20 1.02					20×30 1.20	22×25 1.20	25.4×25 1.16	30×20 1.15	
390	20×30 1.30	22×25 1.30	25.4×25 1.26	30×20 1.25				20×35 1.30	22×30 1.35	25.4×25 1.35	30×20 1.20	
470	20×35 1.34	22×30 1.55	25.4×25 1.55	30×20 1.30				20×40 1.40	22×35 1.50	25.4×30 1.50	30×25 1.50	35×20 1.36
560	20×40 1.50	22×35 1.67	25.4×30 1.67	30×25 1.67	35×20 1.46			20×45 1.55	22×40 1.67	25.4×30 1.67	30×25 1.67	35×20 1.43
680	20×45 1.70	22×40 1.82	25.4×30 1.82	30×25 1.82	35×20 1.51			20×50 1.75	22×45 1.78	25.4×35 1.78	30×30 1.78	35×25 1.83
820		22×45 2.04	25.4×35 2.04	30×30 2.04	35×25 2.04				22×50 2.04	25.4×40 2.04	30×30 2.04	35×25 2.04
1,000		22×50 2.25	25.4×40 2.25	30×30 2.25	35×25 2.25					25.4×45 2.30	30×35 2.30	35×30 2.30
1,200			25.4×45 2.49	30×35 2.49	35×30 2.49					25.4×50 2.55	30×40 2.55	35×30 2.55
1,500			25.4×60 2.97	30×40 2.84	35×30 2.84						30×45 2.90	35×35 2.90
1,800				30×45 3.32	35×35 3.00						30×60 3.49	35×40 3.30
2,200				30×60 3.86	35×45 3.50							35×50 3.65
2,700					35×50 4.00							35×60 4.19
3,300					35×60 4.63							

← Upper : Case size φD×L (mm)
 ← Lower : Rated ripple current (Arms) at 105°C, 120Hz

◆CASE CODE

Case code	Case size φD×L	Case code	Case size φD×L	Case code	Case size φD×L	Case code	Case size φD×L	Case code	Case size φD×L
20S	20×20	22S	22×20	25S	25.4×20	30S	30×20	35S	35×20
20A	20×25	22A	22×25	25A	25.4×25	30A	30×25	35A	35×25
20B	20×30	22B	22×30	25B	25.4×30	30B	30×30	35B	35×30
20C	20×35	22C	22×35	25C	25.4×35	30C	30×35	35C	35×35
20D	20×40	22D	22×40	25D	25.4×40	30D	30×40	35D	35×40
20E	20×45	22E	22×45	25E	25.4×45	30E	30×45	35E	35×45
20F	20×50	22F	22×50	25F	25.4×50	30F	30×50	35F	35×50
—	—	—	—	25H	25.4×60	30H	30×60	35H	35×60

◆RATED RIPPLE CURRENT MULTIPLIERS

●Frequency Multipliers

Frequency (Hz)	50	120	300	1k	10k	50k
160 to 250V _{dc}	0.81	1.00	1.17	1.32	1.45	1.50
315 to 450V _{dc}	0.77	1.00	1.16	1.30	1.41	1.43

◆ STANDARD RATINGS

μF	V _{dc} φD	200					220				
		20	22	25.4	30	35	20	22	25.4	30	35
120		20×20 0.56					20×20 0.56				
150		20×25 0.71	22×20 0.73				20×25 0.73	22×20 0.67			
180		20×25 0.77	22×20 0.80				20×25 0.90		25.4×20 0.76		
220		20×25 1.00		25.4×20 0.85			20×30 1.00	22×25 1.00	25.4×20 0.84		
270		20×30 1.10	22×25 1.10		30×20 1.05		20×35 1.15	22×30 1.15	25.4×25 1.08	30×20 0.98	
330		20×35 1.20	22×30 1.25	25.4×25 1.25	30×20 1.10		20×40 1.25	22×35 1.25	25.4×25 1.25		35×20 1.13
390		20×40 1.31	22×30 1.35	25.4×25 1.35			20×45 1.40	22×35 1.40	25.4×30 1.40	30×25 1.36	35×20 1.23
470		20×45 1.45	22×35 1.50	25.4×30 1.50	30×25 1.50	35×20 1.41	20×50 1.51	22×40 1.51	25.4×35 1.54	30×25 1.50	
560		20×50 1.58	22×40 1.67	25.4×30 1.67	30×25 1.67			22×45 1.70	25.4×40 1.72	30×30 1.70	35×25 1.71
680			22×45 1.78	25.4×35 1.78	30×30 1.78	35×25 1.78			25.4×45 1.94	30×35 1.93	35×25 1.89
820				25.4×45 2.04	30×30 2.04	35×25 2.04			25.4×50 2.18	30×40 2.19	35×30 2.16
1,000				25.4×50 2.30	30×35 2.30	35×30 2.30			25.4×60 2.54	30×45 2.50	35×35 2.44
1,200				25.4×60 2.66	30×40 2.65	35×35 2.65				30×50 2.81	35×40 2.79
1,500					30×50 3.08	35×40 3.08				30×60 3.30	35×45 3.22
1,800					30×60 3.49	35×45 3.48	← Upper : Case size φD×L (mm) ← Lower : Rated ripple current (Arms) at 105°C, 120Hz				35×50 3.63
2,200						35×50 3.78					35×60 4.23

μF	V _{dc} φD	250					315				
		20	22	25.4	30	35	20	22	25.4	30	35
56							20×20 0.38				
68							20×25 0.47	22×20 0.45			
82							20×25 0.64	22×20 0.47			
100		20×20 0.51					20×30 0.69	22×25 0.61	25.4×20 0.56		
120		20×25 0.58	22×20 0.60				20×30 0.75	22×25 0.75	25.4×20 0.62	30×20 0.65	
150		20×25 0.79		25.4×20 0.74			20×35 0.82	22×30 0.82	25.4×25 0.82	30×20 0.70	35×20 0.76
180		20×30 0.90	22×25 0.78	25.4×20 0.75			20×40 0.90	22×35 0.92	25.4×25 0.92	30×25 0.90	35×20 0.85
220		20×30 1.00	22×25 1.00	25.4×25 0.95	30×20 0.95		20×50 1.00	22×40 1.04	25.4×30 1.04	30×25 1.04	35×20 0.90
270		20×35 1.10	22×30 1.18	25.4×25 1.18	30×20 1.00			22×45 1.16	25.4×35 1.16	30×25 1.16	35×25 1.15
330		20×40 1.20	22×35 1.30	25.4×30 1.30	30×25 1.30	35×20 1.16		22×50 1.33	25.4×40 1.33	30×30 1.33	35×25 1.33
390		20×50 1.45	22×40 1.49	25.4×35 1.49	30×25 1.49				25.4×45 1.47	30×35 1.47	35×30 1.47
470			22×45 1.65	25.4×35 1.65	30×30 1.65	35×25 1.65			25.4×50 1.70	30×40 1.70	35×30 1.70
560			22×50 1.67	25.4×40 1.80	30×30 1.80	35×25 1.80				30×45 2.05	35×35 2.05
680				25.4×50 2.00	30×35 2.00	35×30 2.00				30×50 2.17	35×40 2.17
820				25.4×60 2.20	30×40 2.30	35×35 2.30					35×45 2.20
1,000					30×50 2.47	35×40 2.47					35×60 2.55
1,200					30×60 2.85	35×45 2.60					
1,500						35×50 3.00	← Upper : Case size φD×L (mm) ← Lower : Rated ripple current (Arms) at 105°C, 120Hz				
1,800						35×60 3.42					

◆STANDARD RATINGS

μF	V _{dc} φD	350					400				
		20	22	25.4	30	35	20	22	25.4	30	35
39							20×20 0.32				
47		20×20 0.35					20×25 0.39	22×20 0.37			
56		20×25 0.43	22×20 0.41				20×25 0.51		25.4×20 0.42		
68		20×25 0.47		25.4×20 0.46			20×30 0.56	22×25 0.50	25.4×20 0.46		
82		20×30 0.54	22×25 0.55	25.4×20 0.51			20×30 0.64	22×25 0.64		30×20 0.55	
100		20×30 0.60	22×25 0.69		30×20 0.60		20×35 0.70	22×30 0.70	25.4×25 0.70	30×20 0.60	
120		20×35 0.68	22×30 0.75	25.4×25 0.75	30×20 0.65		20×40 0.75	22×35 0.75	25.4×25 0.75	30×25 0.73	35×20 0.75
150		20×40 0.78	22×35 0.82	25.4×30 0.83	30×25 0.82	35×20 0.76	20×45 0.83	22×40 0.88	25.4×30 0.88	30×25 0.88	35×20 0.80
180		20×45 0.87	22×40 0.92	25.4×30 0.92	30×25 0.90			22×45 0.98	25.4×35 0.98	30×30 0.98	35×25 0.98
220		20×50 1.00	22×45 1.05	25.4×35 1.04	30×30 1.02	35×25 1.04		22×50 1.10	25.4×40 1.10	30×30 1.10	35×25 1.10
270			22×50 1.16	25.4×40 1.18	30×30 1.17	35×25 1.20			25.4×45 1.22	30×35 1.22	35×30 1.22
330				25.4×45 1.29	30×35 1.34	35×30 1.22			25.4×50 1.44	30×40 1.44	35×30 1.44
390				25.4×50 1.51	30×40 1.51	35×35 1.47			25.4×60 1.51	30×45 1.60	35×35 1.60
470				25.4×60 1.66	30×45 1.65	35×35 1.69				30×50 1.90	35×40 1.90
560					30×50 1.85	35×40 1.90				30×60 2.10	35×45 2.12
680					30×60 2.15	35×50 1.99	← Upper : Case size φD×L (mm) ← Lower : Rated ripple current (Arms) at 105°C, 120Hz				35×60 2.27
820						35×60 2.31					

μF	V _{dc} φD	420					450				
		20	22	25.4	30	35	20	22	25.4	30	35
39		20×20 0.32					20×25 0.34				
47		20×25 0.39	22×20 0.37				20×25 0.39				
56		20×25 0.51		25.4×20 0.42			20×30 0.51	22×25 0.40			
68		20×30 0.56	22×25 0.50	25.4×20 0.46			20×35 0.56	22×30 0.53	25.4×25 0.50		
82		20×35 0.64	22×25 0.64	25.4×25 0.58	30×20 0.53		20×35 0.64	22×30 0.64	25.4×25 0.64		
100		20×35 0.70	22×30 0.70	25.4×25 0.70	30×20 0.59		20×45 0.69	22×35 0.69	25.4×30 0.69	30×25 0.64	
120		20×40 0.75	22×35 0.75	25.4×30 0.75	30×25 0.73	35×20 0.67	20×50 0.75	22×40 0.80	25.4×30 0.80	30×25 0.80	35×25 0.73
150		20×50 0.88	22×40 0.88	25.4×35 0.88	30×25 0.88			22×45 0.88	25.4×35 0.88	30×30 0.88	35×25 0.75
180			22×45 0.95	25.4×35 0.95	30×30 0.95	35×25 0.94		22×50 1.00	25.4×40 1.00	30×30 1.00	
220			22×50 1.10	25.4×45 1.10	30×35 1.10	35×25 1.10			25.4×45 1.12	30×35 1.12	35×30 1.12
270				25.4×50 1.22	30×40 1.22	35×30 1.22			25.4×60 1.18	30×40 1.28	35×35 1.28
330				25.4×60 1.41	30×45 1.45	35×35 1.45				30×50 1.45	35×40 1.45
390					30×50 1.55	35×40 1.55				30×60 1.51	35×40 1.55
470					30×60 1.79	35×45 1.90					35×50 1.85
560						35×50 2.15	← Upper : Case size φD×L (mm) ← Lower : Rated ripple current (Arms) at 105°C, 120Hz				35×60 1.91
680						35×60 2.27					

SMH Series

- Endurance with ripple current : 85°C 2000 hours
- Non solvent-proof type

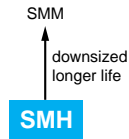

◆SPECIFICATIONS

Items	Characteristics													
Category	-40 to +85°C (6.3 to 100V _{dc}) -25 to +85°C (160 to 450V _{dc})													
Temperature Range														
Rated Voltage Range	6.3 to 450V _{dc}													
Capacitance Tolerance	±20% (M) (at 20°C, 120Hz)													
Leakage Current	I = 0.02CV or 3mA, whichever is smaller. Where, I : Max. leakage current (μA), C : Nominal capacitance (μF), V : Rated voltage (V) (at 20°C after 5 minutes)													
Dissipation Factor (tanδ)	Rated voltage (V _{dc})	6.3V	10V	16V	25V	35V	50V	63V	80V	100V	160 to 250V	315 to 400V	450V	
	tanδ (Max.)	0.60	0.50	0.40	0.30	0.25	0.20	0.15	0.15	0.15	0.10*	0.15	0.15	
	* : 0.15 for D=35mm (at 20°C, 120Hz)													
Low Temperature Characteristics (Max. Impedance Ratio)	Rated voltage (V _{dc})	6.3V	10V	16V	25V	35V	50V	63V	80V	100V	160 to 250V	315 to 400V	450V	
	Z(-25°C)/Z(+20°C)	4	4	4	3	3	2	2	2	2	4	4	8	
	Z(-40°C)/Z(+20°C)	15	15	15	10	8	6	6	5	5	—	—	—	
(at 120Hz)														
Endurance	The following specifications shall be satisfied when the capacitors are restored to 20°C after subjected to DC voltage with the rated ripple current is applied for 2000 hours at 85°C.													
	Capacitance change	≤±20% of the initial value												
	DF (tanδ)	≤200% of the initial specified value												
	Leakage current	≤The initial specified value												
Shelf Life	The following specifications shall be satisfied when the capacitors are restored to 20°C after exposing them for 1000 hours at 85°C without voltage applied.													
	Capacitance change	≤±20% of the initial value												
	DF (tanδ)	≤150% of the initial specified value												
	Leakage current	≤The initial specified value												

◆DIMENSIONS [mm]

●Standard Terminal Type : VSSN (φ22 to φ35)

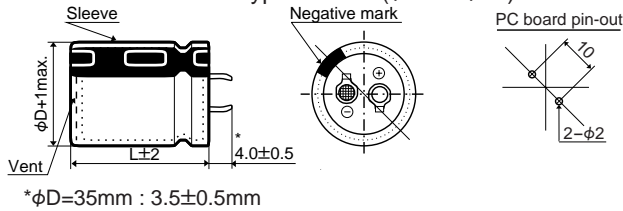

●Terminal Type : VNSN (φ22 to φ35)

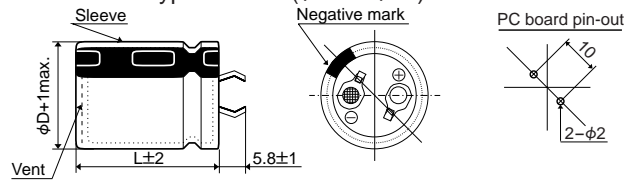

●Terminal Type : LISN (φ35)

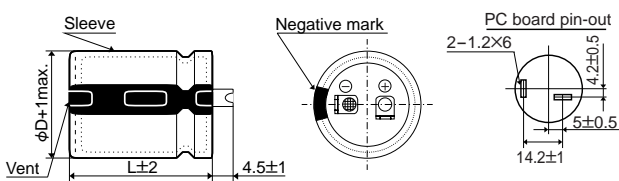

●Terminal Type : LCSN (φ22×30 to 50L)

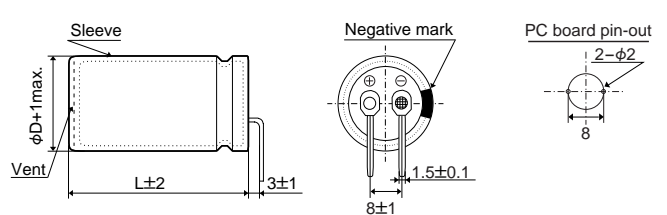

◆PART NUMBERING SYSTEM

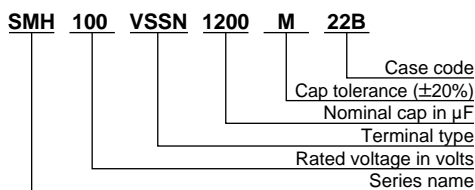

◆STANDARD RATINGS

μF	V _{dc}		6.3				10				16			
	φD		22	25.4	30	35	22	25.4	30	35	22	25.4	30	35
8,200											22×25 2.51			
10,000											22×25 2.77			
12,000							22×25 2.39				22×30 2.86	25.4×25 2.95		
15,000	22×25 2.44						22×30 2.76	25.4×25 2.77			22×35 3.29	25.4×30 3.46	30×25 3.66	
18,000	22×30 2.67	25.4×25 2.70					22×35 3.12	25.4×25 3.04			22×40 3.72	25.4×35 3.98	30×25 4.00	
22,000	22×30 3.06	25.4×25 3.07					22×40 3.55	25.4×30 3.48	30×25 3.53		22×50 4.37	25.4×40 4.26	30×30 4.21	35×25 4.15
27,000	22×35 3.49	25.4×30 3.52	30×25 3.57				22×45 4.04	25.4×35 3.98	30×30 3.73	35×25 3.73		25.4×45 4.72	30×35 4.82	35×30 4.65
33,000	22×40 3.97	25.4×35 4.02	30×25 3.95				22×50 4.58	25.4×40 4.54	30×30 4.13	35×25 4.13		25.4×50 5.33	30×40 5.36	35×30 5.15
39,000	22×50 4.55	25.4×40 4.50	30×30 4.45	35×25 4.51				25.4×45 5.08	30×35 5.05	35×30 4.80			30×45 6.01	35×35 5.95
47,000		25.4×45 5.09	30×35 5.06	35×30 5.01				25.4×50 5.73	30×40 5.72	35×30 5.27			30×50 6.79	35×40 6.76
56,000		25.4×50 5.71	30×40 5.70	35×30 5.77					30×45 6.44	35×35 6.38				35×45 7.62
68,000			30×45 6.48	35×35 6.42					30×50 7.27	35×40 7.27				35×50 8.63
82,000			30×50 7.32	35×40 7.29						35×50 8.49				
100,000							35×45 ←	Upper : Case size φDXL (mm)						
							8.31 ←	Lower : Rated ripple current (Arms) at 85°C, 120Hz						

μF	V _{dc}		25				35				50			
	φD		22	25.4	30	35	22	25.4	30	35	22	25.4	30	35
2,200											22×25 1.91			
3,300											22×30 2.37	25.4×25 2.38		
3,900							22×25 2.22				22×35 2.65	25.4×30 2.68	30×25 2.55	
4,700							22×30 2.41	25.4×25 2.42			22×40 2.99	25.4×35 3.03	30×25 2.81	
5,600	22×25 2.21						22×35 2.75	25.4×25 2.64			22×45 3.36	25.4×35 3.31	30×30 3.37	35×25 3.42
6,800	22×30 2.40	25.4×25 2.56					22×40 2.80	25.4×30 2.74	30×25 2.97		22×50 3.81	25.4×40 3.81	30×35 3.85	35×30 3.85
8,200	22×35 2.72	25.4×25 2.80					22×45 3.47	25.4×35 3.10	30×30 3.13	35×25 2.73		25.4×50 4.37	30×40 4.36	35×30 4.41
10,000	22×40 3.09	25.4×30 3.12	30×25 3.21				22×50 3.57	25.4×40 3.53	30×30 3.46	35×25 3.02			30×45 4.97	35×35 4.92
12,000	22×45 3.48	25.4×35 3.43	30×30 3.86	35×25 3.54				25.4×45 3.98	30×35 4.01	35×30 4.42			30×50 5.60	35×40 5.58
15,000	22×50 4.00	25.4×40 3.95	30×30 4.00	35×25 3.95				25.4×50 4.54	30×40 4.52	35×35 5.01				35×45 6.44
18,000		25.4×45 4.45	30×35 4.46	35×30 4.63					30×45 4.71	35×40 5.54				35×50 6.71
22,000		25.4×50 5.02	30×45 5.21	35×35 5.16					30×50 5.33	35×45 6.04				
27,000			30×50 5.94	35×40 5.92						35×50 6.89				
33,000							35×45 ←	Upper : Case size φDXL (mm)						
							6.75 ←	Lower : Rated ripple current (Arms) at 85°C, 120Hz						
39,000							35×50 7.56							

◆CASE CODE [mm]

Case code	Case size φDXL	Case code	Case size φDXL	Case code	Case size φDXL	Case code	Case size φDXL
22A	22×25	25A	25.4×25	30A	30×25	35A	35×25
22B	22×30	25B	25.4×30	30B	30×30	35B	35×30
22C	22×35	25C	25.4×35	30C	30×35	35C	35×35
22D	22×40	25D	25.4×40	30D	30×40	35D	35×40
22E	22×45	25E	25.4×45	30E	30×45	35E	35×45
22F	22×50	25F	25.4×50	30F	30×50	35F	35×50

◆RATED RIPPLE CURRENT MULTIPLIERS

●Frequency Multipliers

Frequency (Hz)	50	120	300	1k	10k	50k
6.3 to 50V _{dc}	0.95	1.00	1.03	1.05	1.08	1.08
63 to 100V _{dc}	0.92	1.00	1.07	1.13	1.19	1.20
160 to 250V _{dc}	0.81	1.00	1.17	1.32	1.45	1.50
315 to 450V _{dc}	0.77	1.00	1.16	1.30	1.41	1.43

◆ STANDARD RATINGS

μF	V _{dc}		63				80				100			
	φD		22	25.4	30	35	22	25.4	30	35	22	25.4	30	35
820											22×25 1.86			
1,200							22×25 1.69				22×30 2.09	25.4×25 2.10		
1,500							22×25 1.88				22×35 2.41	25.4×30 2.43	30×25 2.46	
1,800	22×25 1.82						22×30 2.14	25.4×25 2.26			22×40 2.71	25.4×35 2.75	30×25 2.72	
2,200	22×30 2.31	25.4×25 2.30					22×35 2.44	25.4×30 2.46	30×25 2.49		22×45 3.08	25.4×40 3.13	30×30 3.09	35×25 3.14
2,700	22×35 2.40	25.4×25 2.40					22×40 2.78	25.4×35 2.81	30×25 2.75		22×50 3.53	25.4×45 3.57	30×35 3.55	35×30 3.71
3,300	22×35 2.62	25.4×30 2.64	30×25 2.78				22×45 3.16	25.4×40 3.21	30×30 3.17	35×25 3.21		25.4×50 4.06	30×40 4.05	35×30 4.05
3,900	22×40 2.93	25.4×35 2.97	30×30 3.00	35×25 3.00			22×50 3.52	25.4×45 3.59	30×35 3.57	35×25 3.50			30×45 4.54	35×35 4.49
4,700	22×50 3.39	25.4×40 3.36	30×30 3.32	35×25 3.36				25.4×50 4.05	30×40 4.05	35×30 4.09			30×50 5.13	35×40 5.11
5,600		25.4×45 3.77	30×35 3.75	35×30 3.76					30×45 4.55	35×35 4.51				35×45 5.75
6,800		25.4×50 4.27	30×40 4.27	35×30 4.15					30×50 5.16	35×40 5.14				35×50 6.50
8,200			30×45 4.83	35×35 4.79						35×45 5.83				
10,000			30×50 5.49	35×40 5.47						35×50 6.63				
12,000				35×45 6.19	← Upper : Case size φD×L (mm) ← Lower : Rated ripple current (Arms) at 85°C, 120Hz									

μF	V _{dc}		160				180				200			
	φD		22	25.4	30	35	22	25.4	30	35	22	25.4	30	35
270							22×25 1.27				22×25 1.27			
330	22×25 1.40						22×25 1.40				22×30 1.45	25.4×25 1.45		
390	22×25 1.52						22×30 1.58	25.4×25 1.58			22×30 1.58	25.4×25 1.58		
470	22×30 1.73	25.4×25 1.74					22×35 1.79	25.4×25 1.79			22×35 1.78	25.4×30 1.80	30×25 1.80	
560	22×35 1.95	25.4×25 1.95					22×40 2.00	25.4×30 1.96	30×25 1.99		22×40 2.00	25.4×35 2.03	30×25 2.00	
680	22×40 2.21	25.4×30 2.16	30×25 2.19				22×45 2.27	25.4×35 2.23	30×25 2.25		22×50 2.33	25.4×40 2.30	30×30 2.28	35×25 2.31
820	22×45 2.49	25.4×35 2.45	30×30 2.50	35×25 2.50			22×50 2.55	25.4×40 2.53	30×30 2.70	35×25 2.53		25.4×45 2.60	30×35 2.59	35×25 2.60
1,000	22×50 2.82	25.4×40 2.79	30×30 2.80	35×25 2.80				25.4×45 2.87	30×35 2.86	35×30 2.99		25.4×50 2.95	30×40 2.95	35×30 2.95
1,200		25.4×45 3.15	30×35 3.13	35×30 3.27				25.4×50 3.30	30×40 3.23	35×35 3.31			30×45 3.31	35×35 3.31
1,500		25.4×50 3.72	30×45 3.73	35×35 3.69					30×50 3.83	35×40 3.82			30×50 3.82	35×40 3.82
1,800			30×50 4.20	35×40 4.18						35×45 4.32				35×45 4.32
2,200				35×45 4.78						35×50 4.92				35×50 4.92
2,700				35×50 5.45	← Upper : Case size φD×L (mm) ← Lower : Rated ripple current (Arms) at 85°C, 120Hz									

◆STANDARD RATINGS

μF	V _{dc}		250				315				350			
	φ	D	22	25.4	30	35	22	25.4	30	35	22	25.4	30	35
82														
100										22×25 0.86				
120							22×25 0.94			22×30 0.99	25.4×25 0.99			
150							22×30 1.11	25.4×25 1.10		22×35 1.14	25.4×25 1.10			
180	22×25 1.04						22×35 1.20	25.4×25 1.20		22×40 1.28	25.4×30 1.24	30×25 1.27		
220	22×25 1.15						22×40 1.41	25.4×30 1.38	30×25 1.40	22×45 1.44	25.4×35 1.44	30×30 1.44	35×25 1.44	
270	22×30 1.31	25.4×25 1.32					22×45 1.60	25.4×35 1.59	30×30 1.59	35×25 1.59	22×50 1.64	25.4×40 1.63	30×35 1.66	35×25 1.63
330	22×35 1.49	25.4×30 1.51	30×25 1.52				22×50 1.82	25.4×40 1.80	30×30 1.80	35×25 1.80		25.4×50 1.88	30×35 1.83	35×30 1.87
390	22×40 1.67	25.4×30 1.66	30×25 1.66					25.4×45 2.01	30×35 1.99	35×30 2.00			30×40 2.06	35×30 2.03
470	22×45 1.88	25.4×35 1.86	30×30 1.89	35×25 1.88				25.4×45 2.20	30×40 2.27	35×30 2.23			30×50 2.40	35×35 2.33
560	22×50 2.10	25.4×40 2.09	30×35 2.14	35×25 2.06					30×45 2.56	35×35 2.49				35×40 2.60
680		25.4×50 2.44	30×40 2.43	35×30 2.46					30×50 2.88	35×40 2.87				35×45 2.96
820			30×45 2.75	35×35 2.77						35×45 3.25				35×50 3.04
1,000			30×50 3.31	35×40 3.32						35×50 3.69				
1,200				35×45 3.53										
1,500				35×50 4.04										

← Upper : Case size φDXL (mm)
 ← Lower : Rated ripple current (Arms) at 85°C, 120Hz

μF	V _{dc}		400				450				
	φ	D	22	25.4	30	35	22	25.4	30	35	
56							22×25 0.65				
68							22×25 0.71				
82	22×25 0.78						22×30 0.82	25.4×25 0.82			
100	22×30 0.90	25.4×25 0.90					22×35 0.93	25.4×25 0.90			
120	22×35 1.02	25.4×25 0.98					22×40 1.04	25.4×30 1.02	30×25 1.03		
150	22×40 1.16	25.4×30 1.14	30×25 1.16				22×45 1.19	25.4×35 1.19	30×30 1.19	35×25 1.19	
180	22×45 1.31	25.4×35 1.30	30×30 1.44	35×25 1.32			22×50 1.34	25.4×40 1.33	30×35 1.35	35×25 1.33	
220	22×45 1.49	25.4×40 1.47	30×30 1.47	35×25 1.47				25.4×50 1.54	30×40 1.55	35×30 1.53	
270	22×50 1.64	25.4×45 1.67	30×35 1.66	35×30 1.69					30×45 1.78	35×35 1.73	
330		25.4×50 1.88	30×40 1.90	35×30 1.87					30×50 2.01	35×40 2.00	
390			30×45 2.13	35×35 2.08						35×45 2.24	
470			30×50 2.40	35×40 2.39						35×50 2.53	
560				35×45 2.69							
680				35×50 3.04							

← Upper : Case size φDXL (mm)
 ← Lower : Rated ripple current (Arms) at 85°C, 120Hz

KMH Series

- Endurance with ripple current : 105°C 2000 hours
- Non solvent-proof type

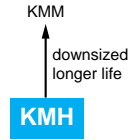

◆SPECIFICATIONS

Items	Characteristics
Category	
Temperature Range	-40 to +105°C (6.3 to 100V _{dc}) -25 to +105°C (160 to 450V _{dc})
Rated Voltage Range	6.3 to 450V _{dc}
Capacitance Tolerance	±20% (M) (at 20°C, 120Hz)
Leakage Current	I=0.02CV (0.03CV for L=20mm) or 3mA, whichever is smaller Where, I : Max. leakage current (µA), C : Nominal capacitance (µF), V : Rated voltage (V) (at 20°C after 5 minutes)
Dissipation Factor (tanδ)	Rated voltage (V _{dc})
	tanδ (Max.)
Low Temperature Characteristics (Max. Impedance Ratio)	Rated voltage (V _{dc})
	Z(-25°C)/Z(+20°C)
	Z(-40°C)/Z(+20°C)
Endurance	The following specifications shall be satisfied when the capacitors are restored to 20°C after subjected to DC voltage with the rated ripple current is applied for 2000 hours at 105°C.
	Capacitance change
	DF (tanδ)
	Leakage current
Shelf Life	The following specifications shall be satisfied when the capacitors are restored to 20°C after exposing them for 1000 hours at 105°C without voltage applied.
	Capacitance change
	DF (tanδ)
	Leakage current

◆DIMENSIONS [mm]

●Standard Terminal Type : VSSN (φ22 to φ35)

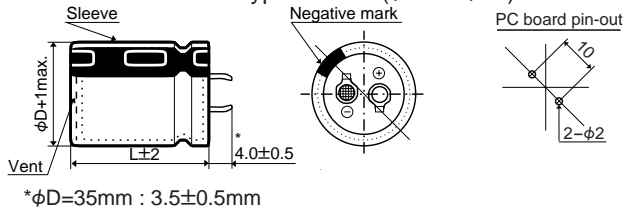

●Terminal Type : VNSN (φ22 to φ35)

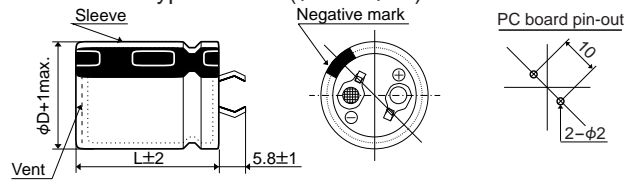

●Terminal Type : LISN (φ35)

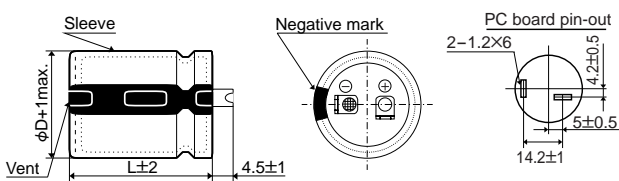

●Terminal Type : LCSN (φ22×30 to 50ℓ)

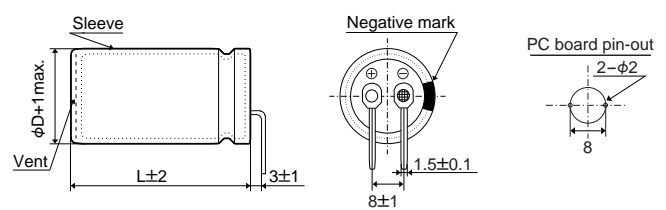

◆PART NUMBERING SYSTEM

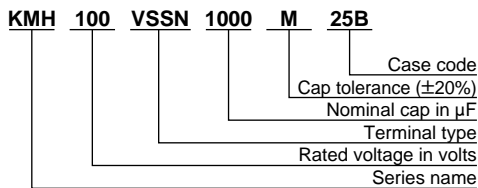



◆STANDARD RATINGS

μF	V _{dc}		6.3				10				16				
	φ	D	22	25.4	30	35	22	25.4	30	35	22	25.4	30	35	
6,800											22×25 1.57				
10,000							22×25 1.55				22×30 1.97	25.4×25 1.97			
12,000			22×25 1.54				22×30 1.77				22×35 2.22	25.4×30 2.24	30×25 2.45		
15,000			22×25 1.72				22×30 1.97	25.4×25 1.96			22×40 2.55	25.4×35 2.58	30×25 2.52		
18,000			22×30 1.95	25.4×25 1.96			22×35 2.21	25.4×30 2.23			22×45 2.87	25.4×40 2.92	30×30 2.88	35×25 2.92	
22,000			22×35 2.23	25.4×30 2.25	30×25 2.28		22×40 2.51	25.4×35 2.54	30×25 2.40			25.4×45 3.32	30×35 3.29	35×25 3.23	
27,000			22×40 2.54	25.4×35 2.57	30×25 2.52		22×50 2.93	25.4×40 2.90	30×30 2.87	35×25 2.73		25.4×50 3.78	30×40 3.77	35×30 3.45	
33,000			22×45 2.88	25.4×40 2.93	30×30 2.89	35×25 2.93		25.4×45 3.30	30×35 3.28	35×30 3.16			30×45 4.30	35×35 4.26	
39,000				25.4×40 3.18	30×35 3.26	35×30 3.40		25.4×50 3.68	30×40 3.69	35×30 3.43			30×50 4.81	35×40 4.79	
47,000				25.4×50 3.69	30×40 3.69	35×30 3.73			30×45 4.17	35×35 3.76				35×45 5.43	
56,000					30×45 4.16	35×35 4.12			30×50 4.68	35×40 4.67					
68,000					30×50 4.71	35×40 4.69				35×50 5.46					
82,000						35×45 5.32	← Upper : Case size φD×L (mm) ← Lower : Rated ripple current (Arms) at 105°C, 120Hz								

μF	V _{dc}		25				35				50				
	φ	D	22	25.4	30	35	22	25.4	30	35	22	25.4	30	35	
1,800											22×25 1.33				
2,700											22×30 1.69	25.4×25 1.70			
3,300							22×25 1.40				22×35 1.93	25.4×30 1.85			
3,900							22×30 1.57				22×40 2.16	25.4×35 2.18	30×25 1.95		
4,700			22×25 1.50				22×30 1.72	25.4×25 1.80			22×45 2.43	25.4×35 2.39	30×30 2.25	35×25 2.48	
5,600			22×25 1.63				22×35 1.95	25.4×30 1.96	30×25 1.99		22×50 2.75	25.4×40 2.70	30×35 2.76	35×25 2.70	
6,800			22×30 1.86	25.4×25 1.87			22×40 2.20	25.4×35 2.23	30×25 2.19			25.4×50 3.30	30×40 3.30	35×30 3.25	
8,200			22×35 2.11	25.4×30 2.12	30×25 2.15		22×50 2.55	25.4×40 2.53	30×30 2.75	35×25 2.75			30×45 3.60	35×35 3.55	
10,000			22×40 2.39	25.4×35 2.42	30×25 2.37			25.4×45 2.87	30×35 2.90	35×30 2.91			30×50 4.04	35×40 4.03	
12,000			22×45 2.69	25.4×40 2.74	30×30 2.70	35×25 2.74		25.4×50 3.24	30×40 3.23	35×30 2.99				35×45 4.55	
15,000				25.4×45 3.15	30×35 3.13	35×30 3.27			30×45 3.72	35×35 3.67					
18,000				25.4×50 3.54	30×40 3.54	35×30 3.58				35×40 4.37					
22,000					30×45 4.04	35×35 3.64				35×50 4.92					
27,000						35×45 4.73	← Upper : Case size φD×L (mm) ← Lower : Rated ripple current (Arms) at 105°C, 120Hz								
33,000						35×50 5.39									

◆CASE CODE [mm]

Case code	Case size φD×L	Case code	Case size φD×L	Case code	Case size φD×L	Case code	Case size φD×L
22S	22×20	25S	25.4×20	30S	30×20	35S	35×20
22A	22×25	25A	25.4×25	30A	30×25	35A	35×25
22B	22×30	25B	25.4×30	30B	30×30	35B	35×30
22C	22×35	25C	25.4×35	30C	30×35	35C	35×35
22D	22×40	25D	25.4×40	30D	30×40	35D	35×40
22E	22×45	25E	25.4×45	30E	30×45	35E	35×45
22F	22×50	25F	25.4×50	30F	30×50	35F	35×50

◆RATED RIPPLE CURRENT MULTIPLIERS

●Frequency Multipliers

Frequency (Hz)	50	120	300	1k	10k	50k
6.3 to 50V _{dc}	0.95	1.00	1.03	1.05	1.08	1.08
63 to 100V _{dc}	0.92	1.00	1.07	1.13	1.19	1.20
160 to 250V _{dc}	0.81	1.00	1.17	1.32	1.45	1.50
315 to 450V _{dc}	0.77	1.00	1.16	1.30	1.41	1.43



◆STANDARD RATINGS

μF	V _{dc} φD	63				80				100			
		22	25.4	30	35	22	25.4	30	35	22	25.4	30	35
560										22×25 1.05			
820					22×25 1.11					22×30 1.32	25.4×25 1.33		
1,000					22×25 1.22					22×35 1.50	25.4×30 1.51		
1,200		22×25 1.19			22×30 1.38	25.4×25 1.39				22×40 1.69	25.4×35 1.71	30×25 1.68	
1,500		22×25 1.33			22×35 1.59	25.4×30 1.61				22×45 1.94	25.4×40 1.98	30×30 1.95	35×25 1.98
1,800		22×30 1.51	25.4×25 1.52		22×40 1.80	25.4×30 1.76	30×25 1.65				25.4×45 2.23	30×35 2.50	35×25 2.17
2,200		22×35 1.73	25.4×30 1.74		22×45 2.04	25.4×35 2.05	30×30 2.05	35×25 2.07			25.4×50 2.53	30×40 2.70	35×30 2.50
2,700		22×40 1.97	25.4×35 1.99	30×25 1.76		25.4×45 2.36	30×35 2.35	35×25 2.29				30×45 2.88	35×35 2.86
3,300		22×50 2.29	25.4×40 2.27	30×30 2.24	35×25 2.06	25.4×50 2.68	30×40 2.68	35×30 2.45				30×50 3.28	35×40 3.27
3,900			25.4×45 2.54	30×35 2.55	35×25 2.24		30×45 3.00	35×35 2.98					35×45 3.67
4,700			25.4×50 2.86	30×40 2.86	35×30 2.79		30×50 3.39	35×40 3.38					35×50 3.80
5,600				30×45 3.22	35×35 3.19			35×45 3.80					
6,800				30×50 3.65	35×40 3.64			35×50 3.90					
8,200					35×45 3.90	← Upper : Case size φDXL (mm) ← Lower : Rated ripple current (Arms) at 105°C, 120Hz							
10,000					35×50 4.40								

μF	V _{dc} φD	160				180				200			
		22	25.4	30	35	22	25.4	30	35	22	25.4	30	35
150										22×20 0.66			
180					22×20 0.73					22×20 0.72			
220		22×20 0.80			22×20 0.80					22×25 0.79	25.4×20 0.83		
270		22×25 1.09			22×25 0.96	25.4×20 0.92				22×25 0.87	25.4×25 1.09		
330		22×25 1.20	25.4×20 1.02		22×25 1.06	25.4×25 1.20				22×30 1.20	25.4×25 1.21	30×20 1.08	
390		22×30 1.30	25.4×25 1.28	30×20 1.17	22×30 1.30	25.4×25 1.30	30×20 1.17			22×35 1.31	25.4×25 1.31	30×25 1.37	
470		22×35 1.40	25.4×25 1.41	30×20 1.28	22×35 1.35	25.4×30 1.40	30×25 1.38	35×20 1.41	22×40 1.40	25.4×30 1.41	30×25 1.50	35×20 1.41	
560		22×40 1.50	25.4×30 1.51	30×25 1.56	35×20 1.54	22×40 1.51	25.4×35 1.53	30×25 1.51	35×20 1.53	22×45 1.56	25.4×35 1.53	30×25 1.63	35×25 1.56
680		22×45 1.71	25.4×35 1.70	30×25 1.72	35×20 1.70	22×45 1.71	25.4×40 1.74	30×30 1.72	35×25 1.74	22×50 1.74	25.4×40 1.74	30×30 1.74	35×25 1.72
820		22×50 1.93	25.4×40 2.01	30×30 2.00	35×25 1.91	22×50 1.97	25.4×45 1.97	30×35 2.00	35×25 1.91		25.4×50 2.04	30×35 2.00	35×30 2.04
1,000			25.4×45 2.20	30×35 2.22	35×25 2.11		25.4×50 2.23	30×40 2.24	35×30 2.26			30×45 2.30	35×35 2.30
1,200			25.4×50 2.45	30×40 2.44	35×30 2.44			30×45 2.52	35×35 2.50			30×50 2.60	35×40 2.65
1,500				30×45 2.82	35×35 2.50			30×50 2.89	35×40 2.89				35×45 3.08
1,800				30×50 3.31	35×45 3.31				35×40 3.17				35×50 3.47
2,200					35×50 3.77				35×50 3.60	← Upper : Case size φDXL (mm) ← Lower : Rated ripple current (Arms) at 105°C, 120Hz			

◆STANDARD RATINGS

μF	V _{dc} φD	250				315				350			
		22	25.4	30	35	22	25.4	30	35	22	25.4	30	35
56										22×20 0.40			
68					22×20 0.44					22×25 0.51			
82					22×25 0.64					22×25 0.56	25.4×20 0.51		
100					22×30 0.68	25.4×20 0.56				22×30 0.69	25.4×25 0.69	30×20 0.59	
120	22×20 0.59				22×30 0.75	25.4×25 0.76	30×20 0.65			22×35 0.75	25.4×25 0.75	30×20 0.64	
150	22×25 0.71				22×35 0.82	25.4×30 0.80	30×25 0.82			22×40 0.82	25.4×30 0.83	30×25 0.83	35×20 0.76
180	22×25 0.78	25.4×20 0.75			22×40 0.91	25.4×30 0.88	30×25 0.90	35×20 0.83		22×45 0.92	25.4×35 0.92	30×25 0.91	35×25 0.94
220	22×30 0.95	25.4×25 0.95	30×20 0.88		22×45 1.02	25.4×35 1.02	30×30 1.02	35×25 1.03		22×50 1.05	25.4×40 1.04	30×30 1.02	35×25 1.04
270	22×35 1.14	25.4×25 1.05	30×20 0.97		22×50 1.16	25.4×40 1.15	30×35 1.17	35×25 1.15			25.4×45 1.18	30×35 1.17	35×30 1.20
330	22×40 1.26	25.4×30 1.20	30×25 1.26	35×20 1.18		25.4×50 1.33	30×35 1.30	35×30 1.32				30×40 1.34	35×30 1.33
390	22×45 1.49	25.4×35 1.49	30×25 1.37	35×25 1.43			30×40 1.46	35×35 1.47				30×45 1.51	35×35 1.47
470	22×50 1.57	25.4×40 1.57	30×30 1.57	35×25 1.57			30×50 1.70	35×40 1.69					35×40 1.69
560		25.4×45 1.79	30×35 1.79	35×30 1.79				35×45 1.90					35×45 1.90
680		25.4×50 1.84	30×40 2.00	35×30 1.97				35×50 2.15					
820			30×45 2.16	35×35 1.98									
1,000				35×40 2.30	← Upper : Case size φD×L (mm) ← Lower : Rated ripple current (Arms) at 105°C, 120Hz								
1,200				35×45 2.43									

μF	V _{dc} φD	400				450			
		22	25.4	30	35	22	25.4	30	35
47	22×20 0.37								
56	22×20 0.40				22×25 0.40				
68	22×25 0.51	25.4×20 0.46			22×30 0.50	25.4×25 0.50			
82	22×30 0.58	25.4×25 0.64			22×35 0.56	25.4×25 0.55			
100	22×30 0.64	25.4×25 0.67	30×20 0.59		22×40 0.64	25.4×30 0.57	30×25 0.64		
120	22×35 0.72	25.4×30 0.72	30×25 0.76		22×45 0.72	25.4×35 0.71	30×25 0.70		
150	22×40 0.82	25.4×35 0.84	30×25 0.84	35×20 0.76	22×50 0.79	25.4×40 0.75	30×30 0.74	35×25 0.75	
180	22×50 0.95	25.4×40 0.94	30×30 0.92	35×25 0.94		25.4×45 0.84	30×35 0.87	35×30 0.90	
220		25.4×45 1.07	30×35 1.06	35×30 1.08		25.4×50 0.98	30×40 0.98	35×30 1.00	
270		25.4×50 1.21	30×40 1.21	35×30 1.20			30×45 1.15	35×35 1.17	
330			30×45 1.39	35×35 1.35			30×50 1.38	35×40 1.38	
390			30×50 1.55	35×40 1.54				35×45 1.55	
470				35×45 1.74				35×50 1.72	



SLM Series

- 15mm height snap-ins
- Endurance with ripple current : 85°C 2000 hours
- Non solvent-proof type

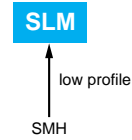

◆ SPECIFICATIONS

Items	Characteristics	
Category	-25 to +85°C	
Temperature Range		
Rated Voltage Range	160 to 400V _{dc}	
Capacitance Tolerance	±20% (M) (at 20°C, 120Hz)	
Leakage Current	$I \leq 3\sqrt{CV}$ Where, I : Max. leakage current (µA), C : Nominal capacitance (µF), V : Rated voltage (V) (at 20°C after 5 minutes)	
Dissipation Factor (tanδ)	Rated voltage (V _{dc})	160 to 400V
	tanδ (Max.)	0.20 (at 20°C, 120Hz)
Low Temperature Characteristics (Max. Impedance Ratio)	Rated voltage (V _{dc})	160 to 400V
	Z (-25°C) / Z (+20°C)	4 (at 120Hz)
Endurance	The following specifications shall be satisfied when the capacitors are restored to 20°C after subjected to DC voltage with the rated ripple current is applied for 2000 hours at 85°C.	
	Capacitance change	≤±20% of the initial value
	DF (tanδ)	≤200% of the initial specified value
	Leakage current	≤The initial specified value
Shelf Life	The following specifications shall be satisfied when the capacitors are restored to 20°C after exposing them for 1000 hours at 85°C without voltage applied.	
	Capacitance change	≤±15% of the initial value
	DF (tanδ)	≤150% of the initial specified value
	Leakage current	≤The initial specified value

◆ DIMENSIONS [mm]

- Terminal Type : VSSN

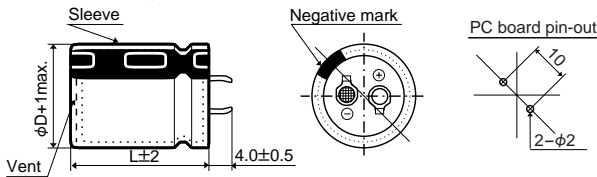

◆ PART NUMBERING SYSTEM

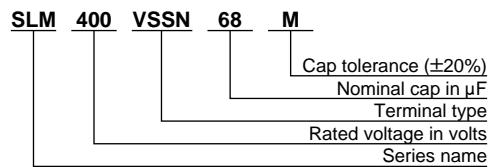

◆ STANDARD RATINGS

Items φD×L (mm)	160		180		200		250		400	
	Capacitance (µF)	Rated ripple (Arms/85°C 120Hz)	Capacitance (µF)	Rated ripple (Arms/85°C 120Hz)	Capacitance (µF)	Rated ripple (Arms/85°C 120Hz)	Capacitance (µF)	Rated ripple (Arms/85°C 120Hz)	Capacitance (µF)	Rated ripple (Arms/85°C 120Hz)
22×15	180	0.99	150	0.90	150	0.90	100	0.73	47	0.50
25.4×15	270	1.29	220	1.16	220	1.16	150	0.96	68	0.65
30×15	390	1.47	330	1.35	270	1.22	220	1.10	100	0.74
35×15	560	1.74	470	1.60	390	1.46	330	1.34	120	0.81

◆ RATED RIPPLE CURRENT MULTIPLIERS

- Frequency Multipliers

Frequency (Hz)	50	120	300	1k	10k	50k
160 to 250V _{dc}	0.81	1.00	1.17	1.32	1.45	1.50
400V _{dc}	0.77	1.00	1.16	1.30	1.41	1.43

KLM Series

- 15mm height snap-ins
- Endurance with ripple current : 105°C 2000 hours
- Non solvent-proof type

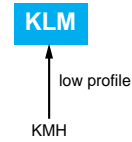

◆ SPECIFICATIONS

Items	Characteristics	
Category	-25 to +105°C	
Temperature Range	-25 to +105°C	
Rated Voltage Range	160 to 400V _{dc}	
Capacitance Tolerance	±20% (M) (at 20°C, 120Hz)	
Leakage Current	$I \leq 3\sqrt{CV}$ Where, I : Max. leakage current (μA), C : Nominal capacitance (μF), V : Rated voltage (V) (at 20°C after 5 minutes)	
Dissipation Factor (tanδ)	Rated voltage (V _{dc})	160 to 400V
	tanδ (Max.)	0.20 (at 20°C, 120Hz)
Low Temperature Characteristics (Max. Impedance Ratio)	Rated voltage (V _{dc})	160 to 400V
	Z (-25°C) / Z (+20°C)	4 (at 120Hz)
Endurance	The following specifications shall be satisfied when the capacitors are restored to 20°C after subjected to DC voltage with the rated ripple current is applied for 2000 hours at 105°C.	
	Capacitance change	≤±20% of the initial value
	DF (tanδ)	≤200% of the initial specified value
	Leakage current	≤The initial specified value
Shelf Life	The following specifications shall be satisfied when the capacitors are restored to 20°C after exposing them for 1000 hours at 105°C without voltage applied.	
	Capacitance change	≤±15% of the initial value
	DF (tanδ)	≤150% of the initial specified value
	Leakage current	≤The initial specified value

◆ DIMENSIONS [mm]

- Terminal Type : VSSN

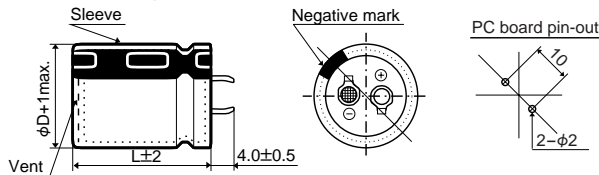

◆ PART NUMBERING SYSTEM

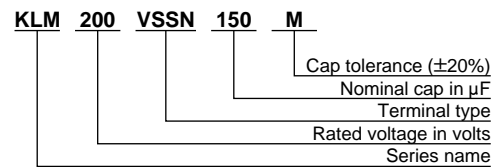

◆ STANDARD RATINGS

Items	160		180		200		250		400	
	Capacitance (μF)	Rated ripple (Arms/105°C 120Hz)	Capacitance (μF)	Rated ripple (Arms/105°C 120Hz)	Capacitance (μF)	Rated ripple (Arms/105°C 120Hz)	Capacitance (μF)	Rated ripple (Arms/105°C 120Hz)	Capacitance (μF)	Rated ripple (Arms/105°C 120Hz)
22×15	150	0.68	120	0.61	120	0.61	82	0.50	39	0.35
25.4×15	180	0.79	150	0.73	150	0.73	100	0.59	47	0.40
	220	0.88	180	0.79			120	0.65	56	0.44
30×15	270	0.96	220	0.86	180	0.79	150	0.71	68	0.46
	330	1.06	270	0.96	220	0.90	180	0.79	82	0.51
35×15	390	1.20	330	1.10	270	1.00	220	0.90	100	0.56
			390	1.17	330	1.07			120	0.62

◆ RATED RIPPLE CURRENT MULTIPLIERS

- Frequency Multipliers

Frequency (Hz)	50	120	300	1k	10k	50k
160 to 250V _{dc}	0.81	1.00	1.17	1.32	1.45	1.50
400V _{dc}	0.77	1.00	1.16	1.30	1.41	1.43

New!

LXM Series

- Downsized and extended life from current long life snap-ins LXG series
- Endurance with ripple current : 105°C 7000 hours
- Non solvent-proof type

LXM

↑
downsized
longer life
LXG



◆ SPECIFICATIONS

Items	Characteristics			
Category	-25 to +85°C			
Temperature Range				
Rated Voltage Range	160 to 450V _{dc}			
Capacitance Tolerance	±20% (M) (at 20°C, 120Hz)			
Leakage Current	I ≤ 3√CV Where, I : Max. leakage current (µA), C : Nominal capacitance (µF), V : Rated voltage (V) (at 20°C after 5 minutes)			
Dissipation Factor (tanδ)	Rated voltage (V _{dc})	160 to 400V	420 & 450V	
	tanδ (Max.)	0.15	0.20 (at 20°C, 120Hz)	
Low Temperature Characteristics (Max. Impedance Ratio)	Rated voltage (V _{dc})	160 to 400V	420 & 450V	
	Z(-25°C)/Z(+20°C)	4	8 (at 120Hz)	
Endurance	The following specifications shall be satisfied when the capacitors are restored to 20°C after subjected to DC voltage with the rated ripple current is applied for 7000 hours at 105°C.			
	Capacitance change	≤ ±20% of the initial value		
	DF (tanδ)	≤ 250% of the initial specified value		
	Leakage current	≤ The initial specified value		
Shelf Life	The following specifications shall be satisfied when the capacitors are restored to 20°C after exposing them for 1000 hours at 105°C without voltage applied.			
	Capacitance change	≤ ±15% of the initial value		
	DF (tanδ)	≤ 150% of the initial specified value		
	Leakage current	≤ The initial specified value		

◆ DIMENSIONS [mm]

● Standard Terminal Type : VSSN (φ22 to φ35)

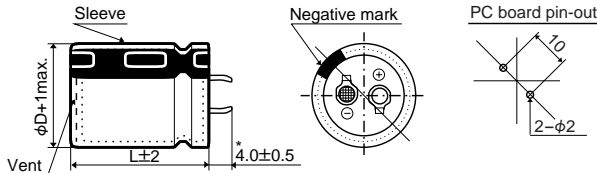

*φD=35mm : 3.5±0.5mm

● Terminal Type : LISN (φ35)

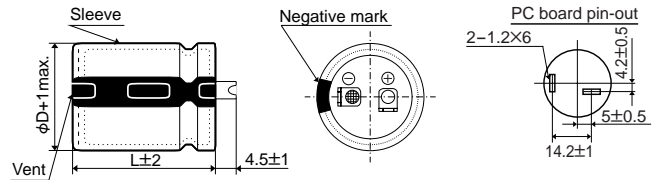

◆ PART NUMBERING SYSTEM

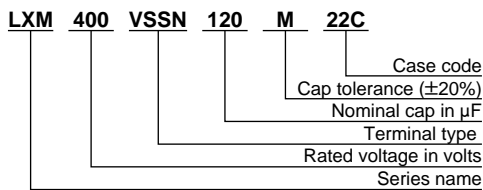

◆ CASE CODE [mm]

Case code	Case size φDXL	Case code	Case size φDXL	Case code	Case size φDXL	Case code	Case size φDXL
22A	22×25	25A	25.4×25	30A	30×25	35A	35×25
22B	22×30	25B	25.4×30	30B	30×30	35B	35×30
22C	22×35	25C	25.4×35	30C	30×35	35C	35×35
22D	22×40	25D	25.4×40	30D	30×40	35D	35×40
22E	22×45	25E	25.4×45	30E	30×45	35E	35×45
22F	22×50	25F	25.4×50	30F	30×50	35F	35×50

◆STANDARD RATINGS

μF	V _{dc} φD	160				180				
		22	25	30	35	22	25	30	35	
270						22×25 1.00				
330		22×25 1.11				22×30 1.16				
390		22×30 1.26				22×30 1.26	25.4×25 1.26			
470		22×30 1.39	25.4×25 1.38			22×35 1.42	25.4×30 1.42			
560		22×35 1.55	25.4×30 1.55			22×40 1.59	25.4×30 1.55	30×25 1.58		
680		22×40 1.75	25.4×35 1.78	30×25 1.74		22×45 1.79	25.4×35 1.78	30×30 1.79		
820		22×50 1.97	25.4×40 2.01	30×30 1.96			25.4×40 2.01	30×35 2.04		
1,000			25.4×45 2.27	30×35 2.26			25.4×50 2.32	30×35 2.26	35×30 2.30	
1,200			25.4×50 2.54	30×40 2.56	35×30 2.52			30×45 2.65	35×35 2.58	
1,500				30×45 2.96	35×35 2.89			30×50 3.03	35×40 3.01	
1,800				30×50 3.32	35×40 3.30				35×45 3.41	
2,200					35×50 3.87	← Upper : Case size φD×L (mm) ← Lower : Rated ripple current (Arms) at 105°C, 120Hz				35×50 3.87

μF	V _{dc} φD	200				220				
		22	25	30	35	22	25	30	35	
220		22×25 0.90				22×25 0.90				
270		22×30 1.05				22×30 1.05				
330		22×30 1.16	25.4×25 1.16			22×35 1.19	25.4×25 1.16			
390		22×35 1.29	25.4×30 1.29			22×40 1.33	25.4×30 1.29			
470		22×40 1.46	25.4×30 1.42	30×25 1.45		22×45 1.49	25.4×35 1.48	30×25 1.45		
560		22×45 1.63	25.4×35 1.62	30×30 1.62		22×50 1.63	25.4×40 1.71	30×30 1.62		
680			25.4×40 1.83	30×30 1.79			25.4×45 1.87	30×35 1.86		
820			25.4×45 2.06	30×35 2.04			25.4×50 2.10	30×40 2.12	35×30 2.08	
1,000				30×45 2.42	35×30 2.30			30×50 2.48	35×40 2.46	
1,200				30×50 2.71	35×40 2.70				35×45 2.78	
1,500					35×45 3.11				35×50 3.20	
1,800					35×50 3.50	← Upper : Case size φD×L (mm) ← Lower : Rated ripple current (Arms) at 105°C, 120Hz				



New!

LXMSeries

◆STANDARD RATINGS

μF	V _{dc} φD	250				315			
		22	25	30	35	22	25	30	35
100						22×25 0.67			
120						22×30 0.77			
150						22×30 0.86	25.4×25 0.85		
180		22×25 0.82				22×35 0.96	25.4×30 0.96		
220		22×30 0.95				22×40 1.09	25.4×30 1.06	30×25 1.08	
270		22×35 1.08	25.4×25 1.05			22×45 1.24	25.4×35 1.23	30×30 1.23	
330		22×40 1.22	25.4×30 1.19				25.4×40 1.40	30×35 1.42	35×30 1.45
390		22×45 1.36	25.4×35 1.35	30×25 1.32			25.4×50 1.59	30×35 1.54	35×30 1.57
470		22×50 1.49	25.4×40 1.52	30×30 1.49				30×45 1.81	35×35 1.77
560			25.4×45 1.70	30×35 1.69				30×50 2.03	35×40 2.02
680			25.4×50 1.91	30×40 1.93	35×30 1.90				35×45 2.29
820				30×45 2.19	35×35 2.13				35×50 2.59
1,000					35×40 2.46				
1,200					35×50 2.86	← Upper : Case size φD×L (mm) ← Lower : Rated ripple current (Arms) at 105°C, 120Hz			

μF	V _{dc} φD	350				400			
		22	25	30	35	22	25	30	35
68						22×25 0.55			
82						22×30 0.63			
100		22×25 0.67				22×30 0.70	25.4×25 0.70		
120		22×30 0.77	25.4×25 0.76			22×35 0.79	25.4×30 0.79		
150		22×35 0.88	25.4×30 0.88			22×40 0.90	25.4×30 0.88	30×25 0.90	
180		22×40 0.99	25.4×30 0.96	30×25 0.98		22×45 0.99	25.4×35 1.01	30×30 1.01	
220		22×45 1.12	25.4×35 1.11	30×30 1.11			25.4×40 1.14	30×35 1.16	
270			25.4×40 1.26	30×35 1.28			25.4×50 1.32	30×40 1.33	35×30 1.31
330			25.4×45 1.40	30×35 1.42	35×30 1.45			30×45 1.52	35×35 1.48
390				30×40 1.60	35×35 1.61			30×50 1.69	35×40 1.68
470				30×50 1.86	35×40 1.85				35×45 1.91
560					35×40 2.02				35×50 2.14
680					35×50 2.36	← Upper : Case size φD×L (mm) ← Lower : Rated ripple current (Arms) at 105°C, 120Hz			



New!

LXMSeries

◆STANDARD RATINGS

μF	V _{dc} φD	420				450			
		22	25	30	35	22	25	30	35
47						22×25 0.46			
56		22×25 0.50				22×30 0.52			
68		22×30 0.58				22×30 0.58	25.4×25 0.58		
82		22×30 0.63	25.4×25 0.63			22×35 0.65	25.4×30 0.65		
100		22×35 0.72	25.4×30 0.72			22×40 0.74	25.4×30 0.72	30×25 0.73	
120		22×40 0.81	25.4×30 0.79	30×25 0.80		22×45 0.83	25.4×35 0.82	30×30 0.82	
150		22×45 0.92	25.4×35 0.92	30×30 0.92			25.4×40 0.94	30×35 0.96	
180			25.4×40 1.03	30×35 1.05			25.4×45 1.06	30×35 1.05	35×30 1.07
220			25.4×50 1.19	30×35 1.16	35×30 1.18			30×40 1.20	35×35 1.21
270				30×45 1.38	35×35 1.34			30×50 1.41	35×40 1.40
330				30×50 1.56	35×40 1.55				35×45 1.60
390					35×45 1.74				35×50 1.79
470					35×50 1.96	← Upper : Case size φD×L (mm) ← Lower : Rated ripple current (Arms) at 105°C, 120Hz			

◆RATED RIPPLE CURRENT MULTIPLIERS

●Frequency Multipliers

Frequency(Hz)	50	120	300	1k	10k	50k
160 to 250V _{dc}	0.81	1.00	1.17	1.32	1.45	1.50
315 to 450V _{dc}	0.77	1.00	1.16	1.30	1.41	1.43

LXG Series

- Endurance with ripple current : 105°C 5000 hours
- Non solvent-proof type

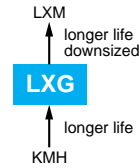

◆ SPECIFICATIONS

Items	Characteristics
Category	-40 to +105°C (10 to 100V _{dc}) -25 to 105°C (200 to 450V _{dc})
Temperature Range	
Rated Voltage Range	10 to 450V _{dc} (at 20°C, 120Hz)
Capacitance Tolerance	±20% (M)
Leakage Current	I=0.02CV or 3mA, whichever is smaller. Where, I : Max. leakage current (μA), C : Nominal capacitance (μF), V : Rated voltage (V) (at 20°C after 5 minutes)
Dissipation Factor (tanδ)	Rated voltage (V _{dc}) 10V 16V 25V 35V 50V 63V 80 & 100V 200 to 400V 450V tanδ (Max.) 0.60 0.45 0.30 0.25 0.20 0.15 0.15 0.15 0.20 (at 20°C, 120Hz)
Low Temperature Characteristics (Max. Impedance Ratio)	Capacitance change : Capacitance at the lowest operating temperature shall not be less than 70% of the 20°C value. Rated voltage (V _{dc}) 10V 16V 25V 35V 50V 63V 80 & 100V 200 to 400V 450V Z(-25°C)/Z(+20°C) 4 4 3 3 2 2 2 4 8 Z(-40°C)/Z(+20°C) 15 15 10 8 6 6 5 - - (at 120Hz)
Endurance	The following specifications shall be satisfied when the capacitors are restored to 20°C after subjected to DC voltage with rated ripple current is applied for 5000 hours at 105°C. Capacitance change ≤±25% of the initial value DF (tanδ) ≤250% of the initial specified value Leakage current ≤The initial specified value
Shelf Life	The following specifications shall be satisfied when the capacitors are restored to 20°C after exposing them for 500 hours at 105°C without voltage applied. Capacitance change ≤±20% of the initial value DF (tanδ) ≤150% of the initial specified value Leakage current ≤The initial specified value

◆ DIMENSIONS [mm]

● Standard Terminal Type : VSSN (φ22 to φ35)

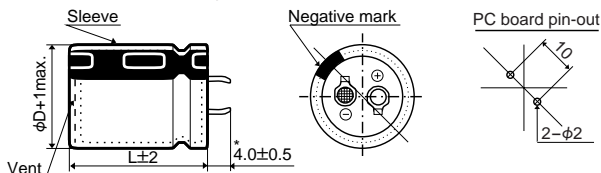

*φD=35mm : 3.5±0.5mm

● Terminal Type : VNSN (φ22 to φ35)

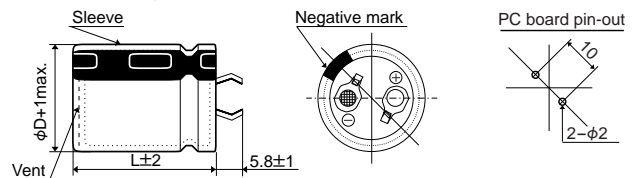

● Terminal Type : LISN (φ35)

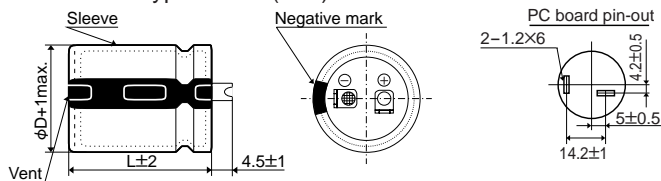

◆ PART NUMBERING SYSTEM

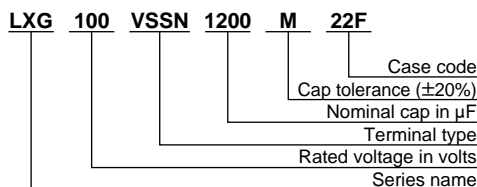

◆ CASE CODE [mm]

Case code	Case size φDXL	Case code	Case size φDXL	Case code	Case size φDXL	Case code	Case size φDXL
22A	22×25	25A	25.4×25	30A	30×25	35A	35×25
22B	22×30	25B	25.4×30	30B	30×30	35B	35×30
22C	22×35	25C	25.4×35	30C	30×35	35C	35×35
22D	22×40	25D	25.4×40	30D	30×40	35D	35×40
22E	22×45	25E	25.4×45	30E	30×45	35E	35×45
22F	22×50	25F	25.4×50	30F	30×50	35F	35×50

◆STANDARD RATINGS

μF	V _{dc}		10				16				25				
	φD		22	25.4	30	35	22	25.4	30	35	22	25.4	30	35	
3,900											22×25 1.31				
4,700											22×30 1.51	25.4×25 1.51			
5,600							22×25 1.44				22×35 1.70				
6,800		22×25 1.30					22×30 1.66	25.4×25 1.66			22×40 1.92	25.4×30 1.87	30×25 1.90		
8,200							22×35 1.87					25.4×35 2.14	30×30 2.15	35×25 2.19	
10,000		22×30 1.65	25.4×25 1.64				22×40 2.12	25.4×30 2.07	30×25 2.11		22×50 2.45	25.4×40 2.43			
12,000		22×35 1.85	25.4×30 1.85	30×25 1.89				25.4×35 2.37	30×30 2.37	35×25 2.42		25.4×50 2.78	30×35 2.70	35×30 2.76	
15,000		22×40 2.12	25.4×35 2.16				22×50 2.74	25.4×40 2.71					30×40 3.13	35×35 3.16	
18,000		22×50 2.45	25.4×40 2.43	30×30 2.37	35×25 2.42			25.4×50 3.11	30×35 3.02	35×30 3.09			30×50 3.64	35×40 3.61	
22,000				30×35 2.73	35×30 2.79				30×40 3.46	35×35 3.49					
27,000			25.4×50 3.11	30×40 3.13					30×50 4.07	35×40 4.04				35×50 4.70	
33,000					35×35 3.49										
39,000				30×50 3.99	35×40 3.96					35×50 5.16					
47,000					35×50 4.62	← Upper : Case size φD×L (mm) ← Lower : Rated ripple current (Arms) at 105°C, 120Hz									

μF	V _{dc}		35				50				63				
	φD		22	25.4	30	35	22	25.4	30	35	22	25.4	30	35	
1,000											22×25 1.00				
1,200											22×30 1.15	25.4×25 1.15			
1,500							22×25 1.02				22×35 1.32				
1,800							22×30 1.17	25.4×25 1.17			22×40 1.49	25.4×30 1.45	30×25 1.48		
2,200		22×25 1.10					22×35 1.33					25.4×35 1.67	30×30 1.68	35×25 1.71	
2,700							22×40 1.51	25.4×30 1.47	30×25 1.50		22×50 1.92	25.4×40 1.90	30×35 1.93		
3,300		22×30 1.42	25.4×25 1.41					25.4×35 1.70	30×30 1.70	35×25 1.74		25.4×50 2.20		35×30 2.18	
3,900		22×35 1.58	25.4×30 1.58				22×50 1.91	25.4×40 1.89					30×40 2.41	35×35 2.43	
4,700		22×40 1.78		30×25 1.77					30×35 2.11	35×30 2.16			30×50 2.80	35×40 2.78	
5,600			25.4×35 1.98	30×30 1.98	35×25 2.03			25.4×50 2.38	30×40 2.39	35×35 2.41					
6,800		22×50 2.26	25.4×40 2.24						30×50 2.79	35×40 2.78				35×50 3.55	
8,200			25.4×50 2.57	30×35 2.50	35×30 2.55										
10,000				30×40 2.86	35×35 2.88					35×50 3.57					
12,000				30×50 3.32	35×40 3.30	← Upper : Case size φD×L (mm) ← Lower : Rated ripple current (Arms) at 105°C, 120Hz									
18,000					35×50 4.29										

◆STANDARD RATINGS

μF	V _{dc}		80				100				200			
	φD		22	25.4	30	35	22	25.4	30	35	22	25.4	30	35
180											22×25 0.63			
270											22×30 0.81	25.4×25 0.81		
330											22×35 0.92	25.4×30 0.92	30×25 0.94	
390							22×25 0.78				22×40 1.02			
470											22×50 1.17	25.4×35 1.15	30×30 1.15	35×25 1.22
560							22×30 0.99	25.4×25 0.98				25.4×40 1.28	30×35 1.30	
680	22×25 0.97						22×35 1.12					25.4×50 1.48	30×40 1.49	35×30 1.47
820	22×30 1.12						22×40 1.26	25.4×30 1.23	30×25 1.25					35×35 1.65
1,000	22×35 1.27	25.4×25 1.23						25.4×35 1.41	30×30 1.42	35×25 1.45			30×50 1.91	35×40 1.90
1,200	22×40 1.42	25.4×30 1.39	30×25 1.41				22×50 1.60	25.4×40 1.59	30×35 1.61					35×50 2.21
1,500		25.4×35 1.62						25.4×50 1.86	30×40 1.87	35×30 1.85				
1,800	22×50 1.84	25.4×40 1.82	30×30 1.78	35×25 1.82						35×35 2.07				
2,200		25.4×50 2.11	30×35 2.05	35×30 2.09					30×50 2.40	35×40 2.39				
2,700			30×40 2.35	35×35 2.37						35×50 2.81				
3,300			30×50 2.75	35×40 2.73										
4,700				35×50 3.46										

← Upper : Case size φD×L (mm)
← Lower : Rated ripple current (Arms) at 105°C, 120Hz

μF	V _{dc}		250				350				400			
	φD		22	25.4	30	35	22	25.4	30	35	22	25.4	30	35
56											22×25 0.34			
68							22×25 0.39				22×30 0.44	25.4×25 0.40		
82							22×30 0.49				22×35 0.50			
100							22×35 0.55	25.4×25 0.49				25.4×30 0.50	30×25 0.51	
120							22×40 0.63	25.4×30 0.55	30×25 0.56		22×40 0.57	25.4×35 0.58		35×25 0.61
150	22×25 0.57							25.4×35 0.60		35×25 0.69	22×50 0.67	25.4×40 0.66	30×30 0.65	
180	22×30 0.66	25.4×25 0.66					22×50 0.73	25.4×40 0.72	30×30 0.71				30×35 0.74	35×30 0.83
220	22×35 0.75							25.4×50 0.93	30×35 0.82	35×30 0.83		25.4×50 0.84	30×40 0.84	35×35 0.94
270	22×40 0.85	25.4×30 0.83	30×25 0.85						30×40 0.94	35×35 1.04			30×50 1.10	35×40 1.09
330		25.4×35 0.96	30×30 0.96	35×25 1.02					30×50 1.19	35×40 1.19				
390	22×50 1.08	25.4×40 1.07												35×50 1.26
470		25.4×50 1.22	30×35 1.19	35×30 1.22						35×50 1.38				
560			30×40 1.35	35×35 1.36										
680			30×50 1.58	35×40 1.57										
1,000				35×50 2.02										

← Upper : Case size φD×L (mm)
← Lower : Rated ripple current (Arms) at 105°C, 120Hz

◆STANDARD RATINGS

μF	V _{dc} φD	450			
		22	25.4	30	35
39	22×25 0.37	Upper : Case size φD×L (mm) Lower : Rated ripple current (Arms) at 105°C, 120Hz			
47	22×30 0.41				
56	22×30 0.44	25.4×25 0.47			
68	22×35 0.50	25.4×30 0.53			
82	22×40 0.56	25.4×30 0.55	30×25 0.57		
100	22×45 0.64	25.4×35 0.63	30×30 0.64		
120	22×50 0.72	25.4×40 0.71	30×30 0.71	35×25 0.71	
150		25.4×45 0.81	30×35 0.81	35×30 0.83	
180		25.4×50 0.91	30×40 0.92	35×35 0.93	
220			30×45 1.05	35×40 1.07	
270				35×45 1.22	
330				35×50 1.39	

◆MAXIMUM IMPEDANCE [mΩ/20°C, 30kHz]

Case size φD×L (mm)	Case code	V _{dc}	Impedance [mΩ/20°C, 30kHz]							
			10 to 63	80	100	200	250	350	400	450
22×25	22A		120	150	640	800	1,000			
22×30	22B		100	120	560	700	900			
22×35	22C		80	95	450	560	720			
22×40	22D		70	80	400	500	650			
22×45	22E		—	—	—	—	590			
22×50	22F		50	60	320	390	500			
25.4×25	25A		90	110	530	660	850			
25.4×30	25B		70	85	420	520	670			
25.4×35	25C		60	70	360	440	570			
25.4×40	25D		50	60	310	380	490			
25.4×45	25E		—	—	—	—	460			
25.4×50	25F		40	45	240	300	390			
30×25	30A		70	80	400	500	650			
30×30	30B		50	60	320	400	520			
30×35	30C		40	50	260	320	410			
30×40	30D		35	40	240	290	370			
30×45	30E		—	—	—	—	340			
30×50	30F		25	30	180	220	280			
35×25	35A		65	70	340	420	540			
35×30	35B		45	50	260	320	410			
35×35	35C		38	40	210	260	330			
35×40	35D		30	30	180	220	280			
35×45	35E		—	—	—	—	260			
35×50	35F		23	25	140	170	220			

◆RATED RIPPLE CURRENT MULTIPLIERS

●Frequency Multipliers

Frequency (Hz)	50	120	300	1k	10k	50k
10 to 50V _{dc}	0.95	1.00	1.03	1.05	1.08	1.08
63 to 100V _{dc}	0.92	1.00	1.07	1.13	1.19	1.20
200 & 250V _{dc}	0.81	1.00	1.17	1.32	1.45	1.50
350 to 450V _{dc}	0.77	1.00	1.16	1.30	1.41	1.43

●105°C Endurance with Rated Ripple Current

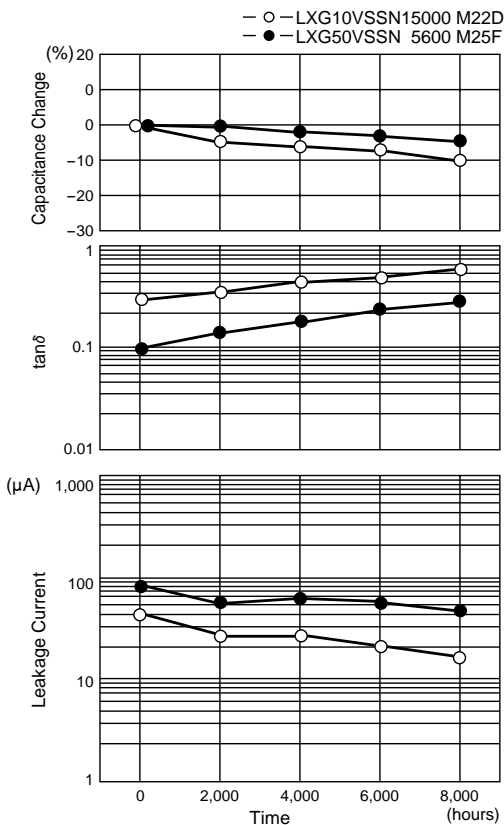

●105°C Endurance with Rated Ripple Current

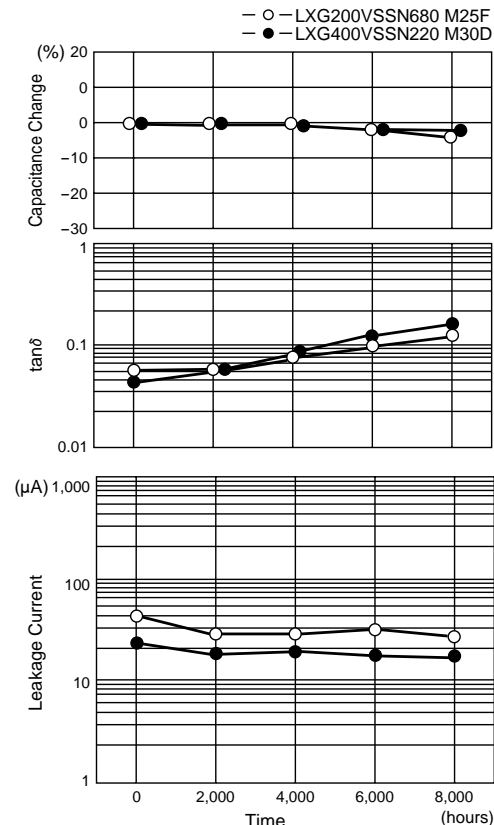



LXH Series

- No sparks against DC over-voltage
- Same case sizes of KMH
- Endurance with ripple current : 105°C 5000 hours
- Non solvent-proof type

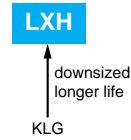

◆ SPECIFICATIONS

Items	Characteristics						
Category Temperature Range	-25 to +105°C						
Rated Voltage	200 & 400V _{dc}						
Capacitance Tolerance	±20% (M) (at 20°C, 120Hz)						
Leakage Current	I=0.02CV or 3mA, whichever is smaller. Where, I : Max. leakage current (µA), C : Nominal capacitance (µF), V : Rated voltage (V) (at 20°C after 5 minutes)						
Dissipation Factor (tanδ)	0.15 max. (at 20°C, 120Hz)						
Low Temperature Characteristics	Z(-25°C) / Z(+20°C) ≤ 4 (at 120Hz)						
ESL	50nH max. (at 20°C, 1MHz)						
DC Overvoltage Test	When an excessive DC voltage is applied to the capacitors under the test conditions on next page, the vent shall operate and then the capacitors shall become open-circuit without burning materials.						
Endurance	The following specifications shall be satisfied when the capacitors are restored to 20°C after subjected to DC voltage with the rated ripple current is applied for 3000 or 5000 hours at 105°C. <table border="1" style="margin-left: 20px;"> <tr> <td>Capacitance change</td> <td>≤ ±20% of the initial value</td> </tr> <tr> <td>DF (tanδ)</td> <td>≤ 200% of the initial specified value</td> </tr> <tr> <td>Leakage current</td> <td>≤ The initial specified value</td> </tr> </table>	Capacitance change	≤ ±20% of the initial value	DF (tanδ)	≤ 200% of the initial specified value	Leakage current	≤ The initial specified value
Capacitance change	≤ ±20% of the initial value						
DF (tanδ)	≤ 200% of the initial specified value						
Leakage current	≤ The initial specified value						
Shelf Life	The following specifications shall be satisfied when the capacitors are restored to 20°C after exposing them for 1000 hours at 105°C without voltage applied. <table border="1" style="margin-left: 20px;"> <tr> <td>Capacitance change</td> <td>≤ ±15% of the initial value</td> </tr> <tr> <td>DF (tanδ)</td> <td>≤ 150% of the initial specified value</td> </tr> <tr> <td>Leakage current</td> <td>≤ The initial specified value</td> </tr> </table>	Capacitance change	≤ ±15% of the initial value	DF (tanδ)	≤ 150% of the initial specified value	Leakage current	≤ The initial specified value
Capacitance change	≤ ±15% of the initial value						
DF (tanδ)	≤ 150% of the initial specified value						
Leakage current	≤ The initial specified value						

◆ DIMENSIONS [mm]

- Standard Terminal Type : VSSN (φ22 to φ35)

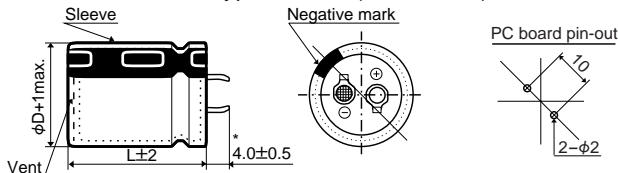

- Terminal Type : VNSN (φ22 to φ35)

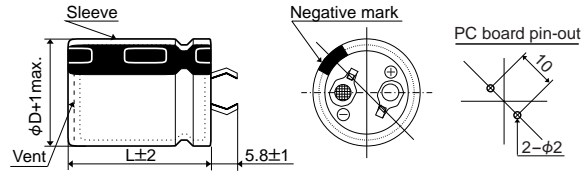

* : φD=35mm : 3.5±0.5mm

◆ PART NUMBERING SYSTEM

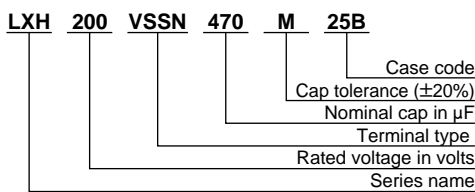

◆ CASE CODE [mm]

Case code	Case size φDXL	Case code	Case size φDXL	Case code	Case size φDXL	Case code	Case size φDXL
22A	22×25	25A	25.4×25	30A	30×25	35A	35×25
22B	22×30	25B	25.4×30	30B	30×30	35B	35×30
22C	22×35	25C	25.4×35	30C	30×35	35C	35×35
22D	22×40	25D	25.4×40	30D	30×40	35D	35×40
22E	22×45	25E	25.4×45	30E	30×45	35E	35×45
22F	22×50	25F	25.4×50	30F	30×50	—	—

◆ RATED RIPPLE CURRENT MULTIPLIERS

- Frequency Multipliers

Frequency (Hz)	50	120	300	1k	10k	50k
200V _{dc}	0.81	1.00	1.17	1.32	1.45	1.50
400V _{dc}	0.77	1.00	1.16	1.30	1.41	1.43

◆STANDARD RATINGS

μF	V _{dc}		200							
	φ		22		25.4		30		35	
270	22×25 ← Upper : Case size φD×L (mm)									
	0.45	0.87								
330	22×30		25.4×25							
	0.62	1.20	0.62	1.21						
390	22×35		25.4×30							
	0.67	1.31	0.66	1.28						
470	22×40		25.4×30		30×25					
	0.72	1.40	0.72	1.41	0.77	1.50				
560	22×45		25.4×35		30×30					
	0.80	1.56	0.78	1.53	0.81	1.57				
680	22×50		25.4×40		30×30		35×25			
	0.89	1.74	0.89	1.74	0.89	1.74	0.88	1.72		
820	↑		25.4×50		30×35		35×30			
			1.05	2.04	1.03	2.00	1.05	2.04		
1,000	↑		↑		30×45		35×35			
					1.18	2.30	1.15	2.23		
1,200	↑		↑		30×50		35×40			
					1.33	2.60	1.36	2.65		
1,500	↑		↑		↑		35×45			
							1.57	3.08		

Rated ripple current for 3000 hours at 105°C (Arms, 120Hz)
Rated ripple current for 5000 hours at 105°C (Arms, 120Hz)

μF	V _{dc}		400							
	φ		22		25.4		30		35	
68	22×25 ← Upper : Case size φD×L (mm)									
	0.26	0.51								
82	22×30		25.4×25							
	0.30	0.58	0.30	0.58						
100	22×35		25.4×30							
	0.34	0.66	0.34	0.66						
120	22×40		25.4×30		30×25					
	0.37	0.72	0.37	0.72	0.39	0.76				
150	22×45		25.4×35		30×30					
	0.42	0.82	0.43	0.84	0.43	0.84				
180	22×50		25.4×40		30×30		35×25			
	0.49	0.95	0.48	0.94	0.47	0.92	0.48	0.94		
220	↑		25.4×45		30×35		35×30			
			0.55	1.07	0.54	1.06	0.55	1.08		
270	↑		25.4×50		30×40		35×30			
			0.62	1.21	0.62	1.21	0.59	1.15		
330	↑		↑		30×45		35×35			
					0.71	1.39	0.69	1.35		
390	↑		↑		30×50		35×40			
					0.80	1.55	0.79	1.54		
470	↑		↑		↑		35×45			
							0.89	1.74		

Rated ripple current for 3000 hours at 105°C (Arms, 120Hz)
Rated ripple current for 5000 hours at 105°C (Arms, 120Hz)

◆DC OVERVOLTAGE TEST CONDITIONS

The vent will operate and the capacitor shall become an open circuit without burning materials when the following excess DC voltage is applied.

●Test DC voltage

Rated Voltage	Capacitance	Current limit	Test DC voltage
200V _{dc}	<330μF	4A	300/375V _{dc}
	330≤C<470μF	5A	
	≥470μF	7A	
400V _{dc}	<100μF	2A	500/600V _{dc}
	100≤C<220μF	4A	
	≥220μF	7A	

●Test Circuit

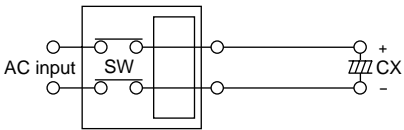

Constant DC voltage/current power supply

●105°C Endurance with Rated Ripple Current

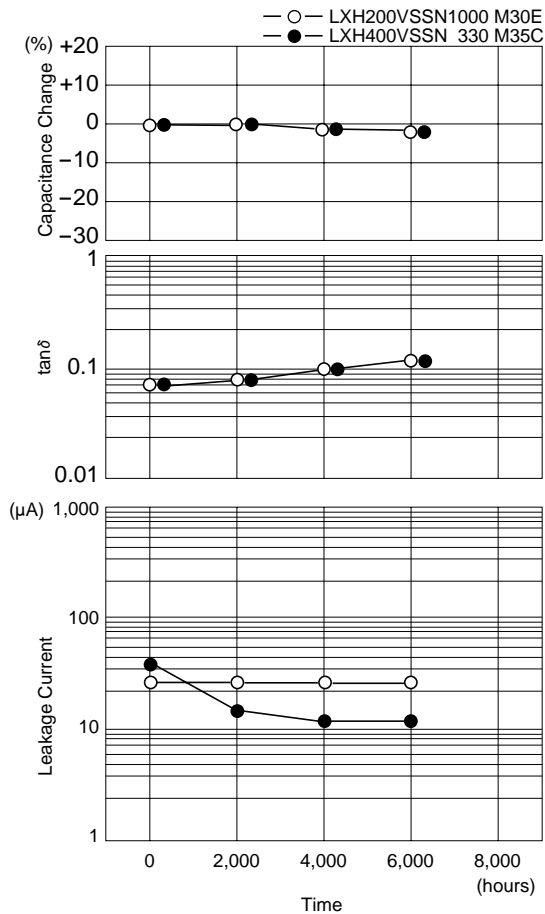

KLG Series

- No sparks against DC over-voltage
- Same case sizes of KMG
- Endurance with ripple current : 105°C 2000 hours
- Non solvent-proof type

LXH
↑
downsized
longer life
KLG



◆ SPECIFICATIONS

Items	Characteristics	
Category Temperature Range	-25 to +105°C	
Rated Voltage Range	200 & 400V _{dc}	
Capacitance Tolerance	±20% (M) (at 20°C, 120Hz)	
Leakage Current	I=0.02CV or 3mA, whichever is smaller. Where, I : Max. leakage current (µA), C : Nominal capacitance (µF), V : Rated voltage (V) (at 20°C after 5 minutes)	
Dissipation Factor (tanδ)	200V _{dc} : 0.10 max. * : 0.15 for D=35mm 400V _{dc} : 0.15 max. (at 20°C, 120Hz)	
Low Temperature Characteristics	Max. Impedance Ratio : Z(-25°C)/Z(+20°C) ≤ 4 (at 120Hz)	
ESL	50nH max. (at 20°C, 1MHz)	
DC Overvoltage Test	When an excessive DC voltage is applied to the capacitors under the test conditions on next page, the vent shall operate and then the capacitors shall become open-circuit without burning materials.	
Endurance	The following specifications shall be satisfied when the capacitors are restored to 20°C after subjected to DC voltage with the rated ripple current is applied for 2000 hours at 105°C.	
	Capacitance change	≤ ±20% of the initial value
	DF (tanδ)	≤ 200% of the initial specified value
	Leakage current	≤ The initial specified value
Shelf Life	The following specifications shall be satisfied when the capacitors are restored to 20°C after exposing them for 1000 hours at 105°C without voltage applied.	
	Capacitance change	≤ ±20% of the initial value
	DF (tanδ)	≤ 150% of the initial specified value
	Leakage current	≤ The initial specified value

◆ DIMENSIONS [mm]

● Standard Terminal Type : VSSN (φ22 to φ35)

● Terminal Type : VNSN (φ22 to φ35)

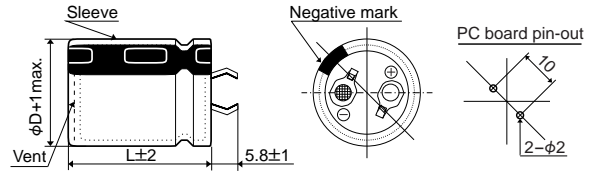
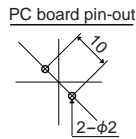
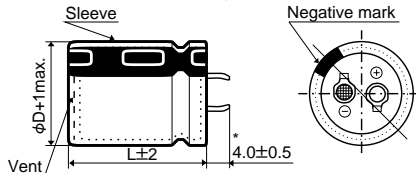

* : φD=35mm : 3.5±0.5mm

◆ PART NUMBERING SYSTEM

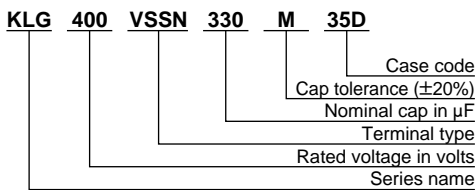

◆ CASE CODE [mm]

Case code	Case size φD×L	Case code	Case size φD×L	Case code	Case size φD×L	Case code	Case size φD×L
22S	22×20	25S	25.4×20	—	—	—	—
22A	22×25	25A	25.4×25	30A	30×25	35A	35×25
22B	22×30	25B	25.4×30	30B	30×30	35B	35×30
22C	22×35	25C	25.4×35	30C	30×35	35C	35×35
22D	22×40	25D	25.4×40	30D	30×40	35D	35×40
22E	22×45	25E	25.4×45	30E	30×45	35E	35×45
22F	22×50	25F	25.4×50	30F	30×50	35F	35×50

◆ RATED RIPPLE CURRENT MULTIPLIERS

● Frequency Multipliers

Frequency (Hz)	50	120	300	1k	10k	50k
200V _{dc}	0.81	1.00	1.17	1.32	1.45	1.50
400V _{dc}	0.77	1.00	1.16	1.30	1.41	1.43

◆STANDARD RATINGS

μF	V _{dc} φD	200			
		22	25.4	30	35
100	22×20 0.50	← Upper : Case size φDXL (mm) ← Lower : Rated ripple current (Arms) at 105°C, 120Hz			
120	22×20 0.56				
150	22×20 0.66	25.4×20 0.65			
180	22×25 0.80	25.4×20 0.70			
220	22×25 0.92				
270	22×30 1.00	25.4×25 1.00			
330	22×35 1.13	25.4×30 1.13			
390	22×40 1.25	25.4×30 1.18	30×25 1.20		
470	22×45 1.32	25.4×35 1.32	30×30 1.32		
560	22×50 1.52	25.4×40 1.50	30×30 1.52	35×25 1.43	
680		25.4×50 1.70	30×35 1.73	35×30 1.73	
820			30×40 1.93	35×35 1.93	
1,000			30×50 2.20	35×40 2.20	
1,200				35×45 2.41	
1,500				35×50 2.82	

μF	V _{dc} φD	400			
		22	25.4	30	35
33	22×20 0.29	← Upper : Case size φDXL (mm) ← Lower : Rated ripple current (Arms) at 105°C, 120Hz			
39	22×20 0.30				
47	22×25 0.36	25.4×20 0.35			
56	22×25 0.39				
68	22×30 0.51	25.4×25 0.49			
82	22×35 0.56	25.4×30 0.53			
100	22×40 0.61	25.4×30 0.64	30×25 0.62		
120	22×45 0.67	25.4×35 0.69	30×30 0.68		
150	22×50 0.77	25.4×40 0.78	30×30 0.76	35×25 0.74	
180		25.4×45 0.83	30×35 0.82	35×30 0.90	
220		25.4×50 0.93	30×40 0.91	35×35 0.99	
270			30×45 1.10	35×35 1.12	
330			30×50 1.24	35×40 1.25	
390				35×45 1.37	
470				35×50 1.50	

◆DC OVERVOLTAGE TEST CONDITIONS

The vent will operate and the capacitor shall become an open circuit without burning materials when the following excess DC voltage is applied.

●Test DC voltage

Rated Voltage	Capacitance	Current limit	Test DC voltage
200V _{dc}	<330μF	4A	300/375V _{dc}
	330≤C<470μF	5A	
	≥470μF	7A	
400V _{dc}	<100μF	2A	500/600V _{dc}
	100≤C<220μF	4A	
	≥220μF	7A	

●Test Circuit

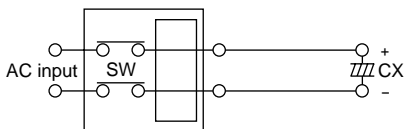

Constant DC voltage/current power supply

●105°C Endurance with Rated Ripple Current

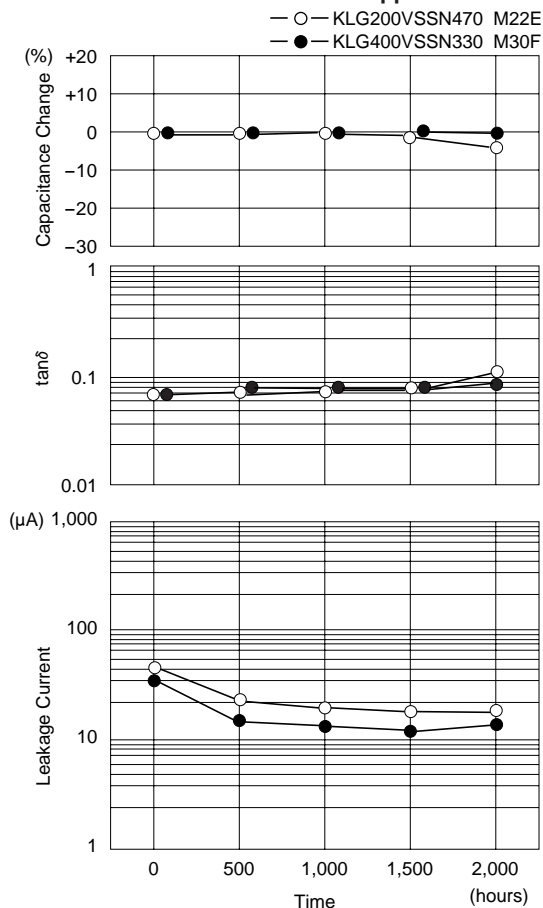

KSL Series

- Mechanically open-mode capacitor (no fire, smoke and electrolyte outside)
- Endurance with ripple current : 105°C 2000 hours
- Non Solvent-proof



◆SPECIFICATIONS

Items	Characteristics						
Category Temperature Range	-25 to +105°C						
Rated Voltage	200 & 400V _{dc}						
Capacitance Tolerance	±20% (M) (at 20°C, 120Hz)						
Leakage Current	$I \leq 3\sqrt{CV}$ Where, I : Max. leakage current (µA), C : Nominal capacitance (µF), V : Rated voltage (V) (at 20°C after 1 minute)						
Dissipation Factor (tanδ)	0.15max. (200V _{dc}), 0.10max. (400V _{dc}) (at 20°C, 120Hz)						
Endurance	The following specifications shall be satisfied when the capacitors are restored to 20°C after DC voltage with rated ripple current is applied for 2000 hours at 105°C.						
	<table border="1"> <tr> <td>Capacitance change</td> <td>≤±20% of the initial value</td> </tr> <tr> <td>DF (tanδ)</td> <td>≤200% of the initial specified value</td> </tr> <tr> <td>Leakage current</td> <td>≤The initial specified value</td> </tr> </table>	Capacitance change	≤±20% of the initial value	DF (tanδ)	≤200% of the initial specified value	Leakage current	≤The initial specified value
Capacitance change	≤±20% of the initial value						
DF (tanδ)	≤200% of the initial specified value						
Leakage current	≤The initial specified value						
Shelf Life	The following specifications shall be satisfied when the capacitors are restored to 20°C after exposing them for 1000 hours at 105°C without voltage applied.						
	<table border="1"> <tr> <td>Capacitance change</td> <td>≤±15% of the initial value</td> </tr> <tr> <td>DF (tanδ)</td> <td>≤150% of the initial specified value</td> </tr> <tr> <td>Leakage current</td> <td>≤The initial specified value</td> </tr> </table>	Capacitance change	≤±15% of the initial value	DF (tanδ)	≤150% of the initial specified value	Leakage current	≤The initial specified value
Capacitance change	≤±15% of the initial value						
DF (tanδ)	≤150% of the initial specified value						
Leakage current	≤The initial specified value						

◆DIMENSIONS [mm]

- Terminal Type : VKSN (φ30 & φ35)

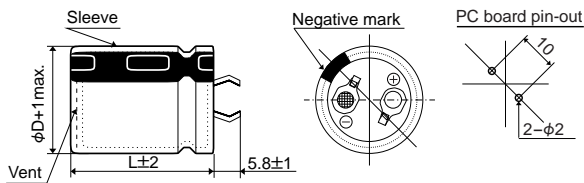

- Terminal Type : LTSN (φ30 & φ35)

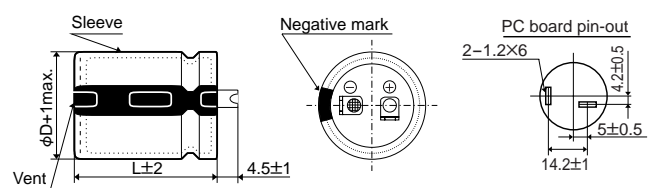

◆PART NUMBERING SYSTEM

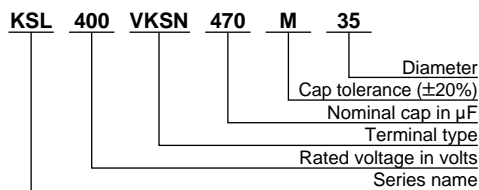

◆RATED RIPPLE CURRENT MULTIPLIERS

- Frequency Multipliers

Frequency (Hz)	50	120	300	1k	10k	50k
200V _{dc}	0.81	1.00	1.17	1.32	1.45	1.50
400V _{dc}	0.77	1.00	1.16	1.30	1.41	1.43

◆STANDARD RATINGS

μF	V _{dc} φD	200			400		
		30		35	30		35
180					30×34	0.92	
220					30×39	1.06	
270					30×44	1.21	35×34
330					30×49	1.39	35×39
390					30×54	1.55	35×44
470							35×49
560	30×34	1.57					35×54
680	30×39	1.80					
820	30×44	2.00	35×34	2.04			
1,000	30×49	2.30	35×39	2.30			
1,200	30×54	2.60	35×44	2.65			
1,500			35×49	3.08			

Rated ripple current (Arms) at 105°C, 120Hz
case size φD×L (mm)

◆DC OVERVOLTAGE TEST CONDITIONS

The safety function will be operated and the capacitor shall become an open circuit without fire, smoke and electrolyte outside when the following excess DC voltage is applied.

●DC voltage test

Rated Voltage	Capacitance	Current limit	Test DC voltage
200V _{dc}	< 330μF	4A	300/375V _{dc}
	330 ≤ C < 470μF	5A	
	≥ 470μF	7A	
400V _{dc}	< 100μF	2A	500/600V _{dc}
	100 ≤ C < 220μF	4A	
	≥ 220μF	7A	

●Test circuit

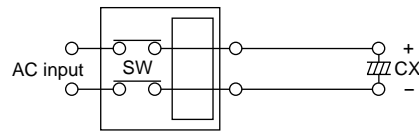

Constant DC voltage/current power supply

◆INSIDE STRUCTURE

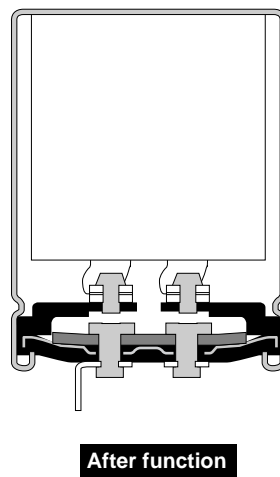
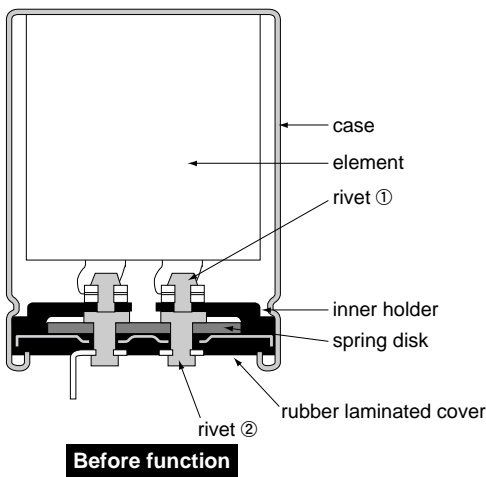

Note : Conformal coating between the cover of the capacitors and the PC board should be avoided.



RWE-LR Series

- For high ripple current application such as air conditioning system
- Endurance with ripple current : 85°C 3000 hours
- Custom-made parts are also available upon requests



◆ SPECIFICATIONS

Items	Characteristics
Category	
Temperature Range	-25 to +85°C
Rated Voltage Range	250V _{dc} 330 to 450V _{dc}
Capacitance Tolerance	±10%, (K) (250V _{dc}) ±20% (M) (330 to 450V _{dc}) (at 20°C, 120Hz)
Leakage Current	I=0.02CV or 3mA, whichever is smaller. Where, I : Max. leakage current (μA), C : Nominal capacitance (μF), V : Rated voltage (V) (at 20°C after 5 minutes)
Dissipation Factor (tanδ)	0.02 max. (250V _{dc}) 0.25 max. (330 to 450V _{dc}) (at 20°C, 120Hz)
Low Temperature Characteristics	Z(-25°C)/Z(+20°C) ≤ 4 (at 120Hz)
Insulation Resistance	When measured between the terminals shorted each other and the mounting clamp on the insulating sleeve covering the case by using an insulation resistance meter of 500V _{dc} , the insulation shall not be less than 100MΩ.
Insulation Withstanding Voltage	When a voltage of 1500V _{ac} is applied for 1 minute between the terminals shorted each other and the mounting clamp on the insulating sleeve covering the case, there shall not be electrical damage.
Endurance	The following specifications shall be satisfied when the capacitors are restored to 20°C after subjected to DC voltage with the rated ripple current is applied for 3000 hours at 85°C.
	Capacitance change ≤ ±20% of the initial value
	DF (tanδ) ≤ 200% of the initial specified value
	Leakage current ≤ The initial specified value
Shelf Life	The following specifications shall be satisfied when the capacitors are restored to 20°C after exposing them for 1000 hours at 85°C without voltage applied.
	Capacitance change ≤ ±15% of the initial value
	DF (tanδ) ≤ 150% of the initial specified value
	Leakage current ≤ The initial specified value

◆ DIMENSIONS [mm]

- Terminal Type : LRSN (φ35 to φ63.5)

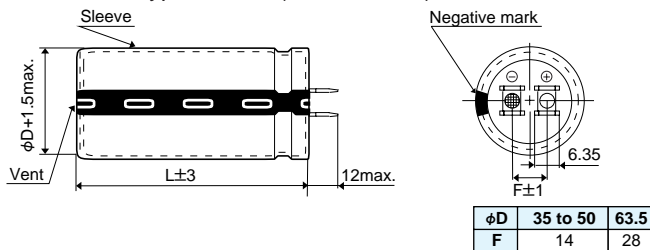

◆ PART NUMBERING SYSTEM

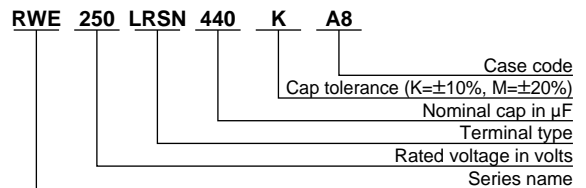

◆ STANDARD RATINGS

μF	250		
	Case size	Case code	Rated ripple (Arms/85°C, 60Hz)
330	35×70	A7	4.5
360	35×70	A7	4.7
390	35×70	A7	4.9
440	35×80	A8	5.4
470	35×80	A8	5.6
500	35×90	A9	6.0

μF	330			350			400		
	Case size	Case code	Rated ripple (Arms/85°C, 120Hz)	Case size	Case code	Rated ripple (Arms/85°C, 120Hz)	Case size	Case code	Rated ripple (Arms/85°C, 120Hz)
1,000	35×80	A8	3.9	35×80	A8	3.9	35×100	A10	4.2
1,300	35×100	A10	4.8	35×100	A10	4.8	40×100	B10	5.2
1,500	35×100	A10	5.2	35×110	A11	5.4	40×110	B11	5.8
	40×90	B9	5.3	40×100	B10	5.5	50×90	C9	6.0
1,800	40×100	B10	6.1	40×110	B11	6.3	50×100	C10	6.9
				50×80	C8	6.2			
2,200	40×110	B11	7.0	50×90	C9	7.3	50×110	C11	7.9

μF	420			450		
	Case size	Case code	Rated ripple (Arms/85°C, 120Hz)	Case size	Case code	Rated ripple (Arms/85°C, 120Hz)
1,000	35×110	A11	4.4	40×100	B10	4.5
1,300	40×110	B11	5.4	50×90	C9	5.6
1,500	50×90	C9	6.0	50×100	C10	6.3
1,800	50×100	C10	6.9	50×120	C12	7.5
2,200	50×120	C12	8.3	63.5×100	D10	8.7



SME Series

●Endurance with ripple current : 85°C 2000 hours

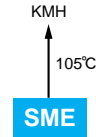

◆SPECIFICATIONS

Items	Characteristics						
Category Temperature Range	-40 to +85°C (10 to 100V _{dc}) -25 to +85°C (160 to 250V _{dc})						
Rated Voltage Range	10 to 250V _{dc}						
Capacitance Tolerance	±20% (M) (at 20°C, 120Hz)						
Leakage Current	I=0.02CV or 5mA, whichever is smaller. Where, I : Max. leakage current (µA), C : Nominal capacitance (µF), V : Rated voltage (V) (at 20°C after 5 minutes)						
Dissipation Factor (tanδ)	Shall not exceed the values shown in the STANDARD RATINGS (at 20°C, 120Hz)						
Low Temperature Characteristics	Capacitance change $C(-25°C)/C(+20°C) \geq 0.7$ (at 120Hz)						
Insulation Resistance	When measured between the terminals shorted each other and the mounting clamp on the insulating sleeve covering the case by using an insulation resistance meter of 500V _{dc} , the insulation resistance shall not be less than 100MΩ.						
Insulation Withstanding Voltage	When a voltage of 2000Vac is applied for 1 minute between the terminals shorted each other and the mounting clamp on the insulating sleeve covering the case, there shall not be electrical damage.						
Endurance	The following specifications shall be satisfied when the capacitors are restored to 20°C after subjected to DC voltage with the rated ripple current is applied for 2000 hours at 85°C. <table border="1" style="width: 100%;"> <tr> <td>Capacitance change</td> <td>≤±20% of the initial value</td> </tr> <tr> <td>DF (tanδ)</td> <td>≤200% of the initial specified value</td> </tr> <tr> <td>Leakage current</td> <td>≤The initial specified value</td> </tr> </table>	Capacitance change	≤±20% of the initial value	DF (tanδ)	≤200% of the initial specified value	Leakage current	≤The initial specified value
Capacitance change	≤±20% of the initial value						
DF (tanδ)	≤200% of the initial specified value						
Leakage current	≤The initial specified value						
Shelf Life	The following specifications shall be satisfied when the capacitors are restored to 20°C after exposing them for 500 hours at 85°C without voltage applied. <table border="1" style="width: 100%;"> <tr> <td>Capacitance change</td> <td>≤±20% of the initial value</td> </tr> <tr> <td>DF (tanδ)</td> <td>≤150% of the initial specified value</td> </tr> <tr> <td>Leakage current</td> <td>≤The initial specified value</td> </tr> </table>	Capacitance change	≤±20% of the initial value	DF (tanδ)	≤150% of the initial specified value	Leakage current	≤The initial specified value
Capacitance change	≤±20% of the initial value						
DF (tanδ)	≤150% of the initial specified value						
Leakage current	≤The initial specified value						

◆DIMENSIONS (Terminal Type=LGSN) [mm]

●B Type of Mounting Clamp

●C Type of Mounting Clamp

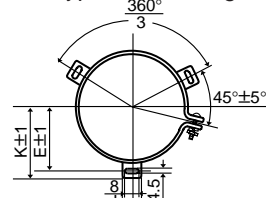
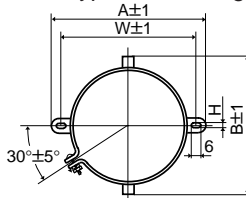
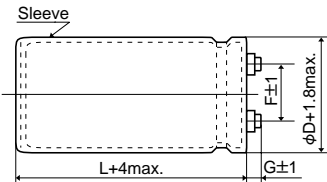

φD	A	B	W	H	F
35	58	44	48	3.5	12.7
50	78	64	68	4.5	22.4
63.5	90	76	80	4.5	28.0
76	104.5	90	93.5	4.5	31.5

φD	E	K	J	F
50	32.5	37.0	14.0	22.4
63.5	38.1	43.5	14.0	28.0
76	44.5	50.0	14.0	31.5
89	50.8	56.5	16.0	31.5

<Screw specifications>

Plus hexagon-headed screw:
M5×0.8×10

Maximum screw tightening torque:
3.23Nm

φ35 to φ63.5 : G=6
φ76 & φ89 : G=5

* The screw and the mounting clamp are separately supplied and not attached to the product.

◆PART NUMBERING SYSTEM

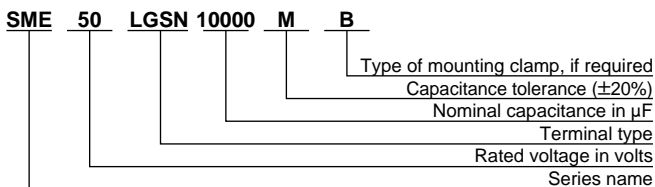

◆CASE CODE

φD (mm)	L (mm)	50	80	100	120	140
35	A5	A8	A10	A12	—	—
50	—	C8	C10	C12	—	—
63.5	—	—	D10	D12	—	—
76	—	—	E10	E12	E14	—
89	—	—	—	—	F14	—

◆RATED RIPPLE CURRENT MULTIPLIERS

●Frequency Multipliers

Rated voltage (V _{dc})	Case diameter (mm)	Frequency (Hz)					
		50	120	300	1k	10k	50k
10 to 50	φ35 to φ89	0.95	1.00	1.03	1.05	1.09	1.12
	φ35	0.90	1.00	1.06	1.10	1.18	1.22
63 & 80	φ50 to φ89	0.95	1.00	1.03	1.05	1.09	1.12
	φ35	0.82	1.00	1.12	1.22	1.30	1.33
100	φ50	0.90	1.00	1.06	1.10	1.18	1.22
	φ63.5 to φ89	0.95	1.00	1.03	1.05	1.09	1.12
160 to 250	φ35	0.80	1.00	1.19	1.34	1.46	1.52
	φ50 & φ63.5	0.81	1.00	1.14	1.26	1.36	1.41
	φ76 & φ89	0.82	1.00	1.12	1.22	1.30	1.33



SME Series

◆ **STANDARD RATINGS**

μF	V _{dc}			10			16			25			35			50			63			80					
	SV			13			20			32			44			63			79			100					
3,300																									A 5	2.5	0.15
3,900																											
4,700																											
5,600																									A 5	3.0	0.20
6,800																									A 8	3.7	0.20
8,200																											
10,000																											
12,000																											
15,000																											
18,000																											
22,000																											
27,000																											
33,000																											
39,000																											
47,000																											
56,000																											
68,000																											
82,000																											
100,000																											
120,000																											
150,000																											
180,000																											
220,000																											
270,000																											
330,000																											
390,000																											
470,000																											
560,000																											
680,000																											

μF	V _{dc}			100			160			200			250		
	SV			125			200			250			300		
560													A 5	1.3	0.15
680															
820													A 5	1.6	0.15
1,000															
1,200													A 8	2.3	0.15
1,500													A 10	3.0	0.15
1,800													A 8	2.8	0.15
2,200													A 12	3.3	0.15
2,700													C 8	3.7	0.15
3,300															
3,900															
4,700															
5,600															
6,800															
8,200															
10,000															
12,000															
15,000															
18,000															
22,000															
27,000															
33,000															
39,000															
47,000															
68,000															

KMH Series

- Downsized from KME series
- Endurance with ripple current : 105°C 2000 hours

KMH

105°C
↑
SME



◆ SPECIFICATIONS

Items	Characteristics
Category	
Temperature Range	-40 to +105°C (10 to 100V _{dc}) -25 to +105°C (160 to 400V _{dc})
Rated Voltage Range	10 to 400V _{dc}
Capacitance Tolerance	±20% (M) (at 20°C, 120Hz)
Leakage Current	I=0.02CV or 5mA, whichever is smaller. Where, I : Max. leakage current (μA), C : Nominal capacitance (μF), V : Rated voltage (V) (at 20°C after 5 minutes)
Dissipation Factor (tanδ)	Shall not exceed the values shown in the STANDARD RATINGS (at 20°C, 120Hz)
Low Temperature Characteristics	Capacitance change 10 to 100V _{dc} : C(-40°C)/C(+20°C) ≥ 0.6 160 to 400V _{dc} : C(-25°C)/C(+20°C) ≥ 0.7 (at 120Hz)
Insulation Resistance	When measured between the terminals shorted each other and the mounting clamp on the insulating sleeve covering the case by using an insulation resistance meter of 500V _{dc} , the insulation resistance shall not be less than 100MΩ.
Insulation Withstanding Voltage	When a voltage of 2000V _{ac} is applied for 1 minute between the terminals shorted each other and the mounting clamp on the insulating sleeve covering the case, there shall not be electrical damage.
Endurance	The following specifications shall be satisfied when the capacitors are restored to 20°C after subjected to DC voltage with the rated ripple current is applied for 2000 hours at 105°C.
	Capacitance change ≤ ±20% of the initial value
	DF (tanδ) ≤ 200% of the initial specified value
	Leakage current ≤ The initial specified value
Shelf Life	The following specifications shall be satisfied when the capacitors are restored to 20°C after exposing them for 500 hours at 105°C without voltage applied.
	Capacitance change ≤ ±20% of the initial value
	DF (tanδ) ≤ 200% of the initial specified value
	Leakage current ≤ The initial specified value

◆ DIMENSIONS (Terminal Type=LGSN) [mm]

● B Type of Mounting Clamp

● C Type of Mounting Clamp

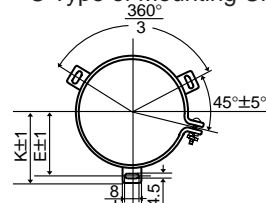
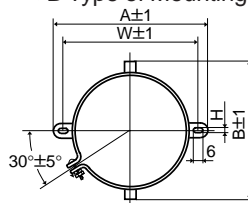
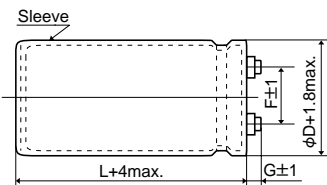

φD	A	B	W	H	F
35	58	44	48	3.5	12.7
50	78	64	68	4.5	22.4
63.5	90	76	80	4.5	28.0
76	104.5	90	93.5	4.5	31.5

φD	E	K	J	F
50	32.5	37.0	14.0	22.4
63.5	38.1	43.5	14.0	28.0
76	44.5	50.0	14.0	31.5
89	50.8	56.5	16.0	31.5

φ35 to φ63.5 : G=6
φ76 & φ89 : G=5

<Screw specifications>
Plus hexagon-headed screw:
M5×0.8×10
Maximum screw tightening torque:
3.23Nm

* The screw and the mounting clamp are separately supplied and not attached to the product.

◆ PART NUMBERING SYSTEM

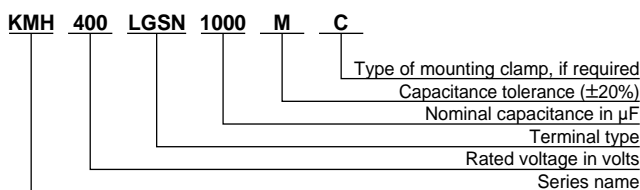

◆ CASE CODE

φD (mm)	L (mm)	50	60	80	100	120	130	140
35	A5	A6	A8	A10	A12	—	—	—
50	—	—	C8	C10	C12	—	—	—
63.5	—	—	—	D10	D12	—	—	—
76	—	—	—	E10	E12	E13	E14	—
89	—	—	—	—	—	—	F14	—

◆ RATED RIPPLE CURRENT MULTIPLIERS

● Frequency Multipliers

Rated voltage (V _{dc})	Case diameter (mm)	Frequency (Hz)					
		50	120	300	1k	10k	50k
10 to 50	φ35 to φ89	0.95	1.00	1.03	1.05	1.09	1.12
	φ35	0.90	1.00	1.06	1.10	1.18	1.22
63 & 80	φ50 to φ89	0.95	1.00	1.03	1.05	1.09	1.12
	φ35	0.82	1.00	1.12	1.22	1.30	1.33
100	φ50	0.90	1.00	1.06	1.10	1.18	1.22
	φ63.5 to φ89	0.95	1.00	1.03	1.05	1.09	1.12
	φ35	0.80	1.00	1.19	1.34	1.46	1.52
160 to 250	φ50 & φ63.5	0.81	1.00	1.14	1.26	1.36	1.41
	φ76 & φ89	0.82	1.00	1.12	1.22	1.30	1.33
	φ35 to φ89	0.80	1.00	1.19	1.34	1.46	1.52
315 to 400	φ35 to φ89	0.80	1.00	1.19	1.34	1.46	1.52



◆ STANDARD RATINGS

μF	V _{dc} SV			10			16			25			35			50			63			80		
				13			20			32			44			63			79			100		
2,200																						A 5	2.4	0.15
2,700																						A 5	2.7	0.15
3,300																						A 5	2.5	0.20
3,900																						A 5	2.8	0.20
4,700																						A 5	2.8	0.20
5,600																						A 5	3.1	0.20
6,800																						A 5	3.1	0.20
8,200																						A 5	3.3	0.20
10,000																						A 5	3.3	0.20
12,000																						A 6	3.5	0.20
15,000																						A 5	3.3	0.25
18,000																						A 6	3.9	0.20
22,000																						A 8	4.7	0.20
27,000																						A 8	4.7	0.20
33,000																						A 10	5.1	0.20
39,000																						A 5	3.7	0.35
47,000																						A 6	4.2	0.30
56,000																						A 6	4.2	0.30
68,000																						A 8	5.1	0.25
82,000																						A 8	5.1	0.25
100,000																						A 10	5.5	0.25
120,000																						A 5	4.1	0.35
150,000																						A 6	4.7	0.30
180,000																						A 8	5.7	0.25
220,000																						A 6	4.8	0.35
270,000																						A 8	5.7	0.30
330,000																						A 8	6.3	0.30
390,000																						A 10	7.5	0.30
470,000																						A 12	9.0	0.30
560,000																						C 8	9.2	0.35
680,000																						C 10	11.2	0.35
820,000																						C 10	11.2	0.45
1,000,000																						C 10	11.2	0.50
1,200,000																						D 10	14.8	0.45
1,500,000																						D 10	14.8	0.45
1,800,000																						D 12	17.6	0.45
2,200,000																						D 12	17.6	0.55
2,700,000																						E 12	19.8	0.65
3,300,000																						E 12	19.8	0.80
3,900,000																						F 14	23.9	0.75
4,700,000																						F 14	23.9	0.75
5,600,000																								
6,800,000																								
8,200,000																								
10,000,000																								
12,000,000																								
15,000,000																								
18,000,000																								
22,000,000																								
27,000,000																								
33,000,000																								
39,000,000																								
47,000,000																								
560,000																								
680,000																								

μF	V _{dc} SV			100			160			200			250			315			350			400			
				125			200			250			300			365			400			450			
180																	A 5	0.8	0.10	A 5	0.8	0.10	A 5	0.8	0.10
220																	A 5	0.9	0.10	A 5	0.9	0.10	A 5	0.9	0.10
270																	A 5	1.0	0.10	A 5	1.0	0.10	A 5	1.0	0.10
330																	A 5	1.1	0.10	A 5	1.1	0.10	A 6	1.2	0.10
390																	A 5	1.2	0.10	A 5	1.2	0.10	A 6	1.3	0.10
470																	A 5	1.1	0.15	A 5	1.1	0.15	A 6	1.4	0.10
560																	A 6	1.4	0.10	A 6	1.4	0.10	A 6	1.4	0.10
680																	A 6	1.4	0.15	A 6	1.4	0.15	A 8	1.6	0.10
820																	A 6	1.5	0.10	A 6	1.5	0.10	A 8	1.6	0.10
1,000																	A 8	1.7	0.10	A 8	1.7	0.10	A 8	1.6	0.15
1,200																	A 8	1.7	0.15	A 8	1.7	0.15	A 8	1.6	0.15
1,500																	A 8	1.6	0.15	A 8	1.6	0.15	A 10	1.8	0.15
1,800																	A 10	2.0	0.15	A 10	2.0	0.15	A 12	2.2	0.15
2,200																	A 12	2.4	0.15	A 12	2.4	0.15	C 8	2.4	0.15
2,700																	C 8	2.7	0.15	C 8	2.7	0.15	C 10	3.0	0.15
3,300																	C 10	3.3	0.15	C 10	3.3	0.15	C 12	3.6	0.15
3,900																	C 12	4.0	0.15	C 12	4.0	0.15	C 12	4.0	0.15
4,700																	C 12	4.4	0.15	C 12	4.4	0.15	D 10	4.6	0.15
5,600																	D 10	5.1	0.15	D 10	5.1	0.15			
6,800																	D 12	6.0	0.15	D 12	6.0	0.15	E 12	6.7	0.15
8,200																	E 12	6.8	0.15	E 12	6.8	0.15			
10,000																	E 12	8.0	0.15	E 12	8.0	0.15	E 13	8.3	0.15
12,000																	E 13	9.2	0.15	E 13	9.2	0.15	E 14	9.5	0.15
15,000																	F 14	11.4	0.15	F 14	11.4	0.15	F 14	11.4	0.15
18,000																	F 14	12.6	0.15	F 14	12.6	0.15			
22,000																									
27,000																									
33,000																									
39,000																									
47,000																									
560,000																									



RWE Series

- 350 to 550V_{dc}
- Endurance with ripple current : 85°C 2000 hours

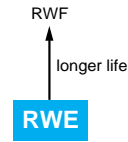

◆ SPECIFICATIONS

Items	Characteristics			
Category Temperature Range	-25 to +85°C			
Rated Voltage Range	350 to 550V _{dc}			
Capacitance Tolerance	±20% (M) (at 20°C, 120Hz)			
Leakage Current	I=0.02CV or 5mA, whichever is smaller. Where, I : Max. leakage current (μA), C : Nominal capacitance (μF), V : Rated voltage (V) (at 20°C after 5 minutes)			
Dissipation Factor (tanδ)	0.25 max. (at 20°C, 120Hz)			
Low Temperature Characteristics	Capacitance change	Rated Voltage (V _{dc})	350 to 450V	500 & 550V
		C(-25°C)/C(+20°C)	0.7min.	0.6min.
	(at 120Hz)			
Insulation Resistance	When measured between the terminals shorted each other and the mounting clamp on the insulating sleeve covering the case by using an insulation resistance meter of 500Vdc, the insulation resistance shall not be less than 100MΩ.			
Insulation Withstanding Voltage	When a voltage of 2000Vac is applied for 1 minute between the terminals shorted each other and the mounting clamp on the insulating sleeve covering the case, there shall not be electrical damage.			
Endurance	The following specifications shall be satisfied when the capacitors are restored to 20°C after subjected to DC voltage with the rated ripple current is applied for 2000 hours at 85°C.			
	Capacitance change	≤±20% of the initial value		
	DF (tanδ)	≤300% of the initial specified value		
	Leakage current	≤The initial specified value		
Shelf Life	The following specifications shall be satisfied when the capacitors are restored to 20°C after exposing them for 500 hours at 85°C without voltage applied.			
	Capacitance change	≤±20% of the initial value		
	DF (tanδ)	≤300% of the initial specified value		
	Leakage current	≤The initial specified value		

◆ DIMENSIONS (Terminal Type=LGSN) [mm]

● B Type of Mounting Clamp

● C Type of Mounting Clamp

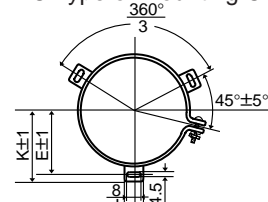
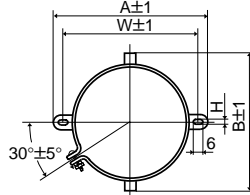
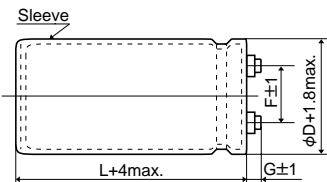

φD	A	B	W	H	F
35	58	44	48	3.5	12.7
50	78	64	68	4.5	22.4
63.5	90	76	80	4.5	28.0
76	104.5	90	93.5	4.5	31.5

φD	E	K	F	J
50	32.5	37.0	22.4	14.0
63.5	38.1	43.5	28.0	14.0
76	44.5	50.0	31.5	14.0
89	50.8	56.5	31.5	16.0

φ35 to φ63.5 : G=6
φ76 & φ89 : G=5

<Screw specifications>
Plus hexagon-headed screw:
M5×0.8×10
Maximum screw tightening torque:
3.23Nm

* The screw and the mounting clamp are separately supplied and not attached to the product.

◆ PART NUMBERING SYSTEM

RWE 550 LGSN 820 M C C13

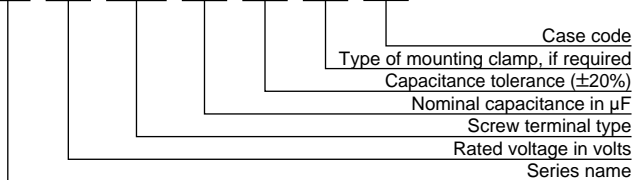

◆STANDARD RATINGS

μF \ V _{dc}	350		400		450		500		550							
100	<div style="display: flex; justify-content: space-around;"> <div style="text-align: center;"> <p>Case code</p> <p>Rated ripple current (Arms) at 85°C, 120Hz</p> </div> </div>										A5		0.6			
120											A5		0.7			
180											A8		1.0			
270											A10		1.3			
330											A12		1.6			
390	A5	1.9	A5		1.7	A8		1.2	A10		1.3					
470	A10		A12		3.9	C7		3.9	C13		D9	3.4	3.4			
560	A8		A10		3.4	A12		3.5	C9		2.5	C11		D11	2.7	3.0
680	A10		A12		3.9	C7		4.2	C9		2.5	C11		D11	2.7	3.0
820	C7		C9		6.3	C13		7.2	D9		7.2	E11		E15		7.0
1,000	C9		D9		7.9	D11		8.6	E15		7.7					
1,200	C13	D9	8.8	8.8	D11	9.5	D13	E9	10.0	9.8			F15		9.3	
1,500	D11		10.3		D13	E9	10.9	10.6	E11		11.5		F15		10.1	
1,800	D13	E9	12.0	11.7	E11		12.6		E13		13.3					
2,200	E11		12.6		E13		14.5		E15		15.7					
2,700	E13		15.9		E15		17.3									
3,300	E15		19.0		F15		18.6									
3,900			20.5													
4,700	F15		22.5													
5,600																
6,800																
8,200																
10,000																
12,000																

◆CASE CODE

$\phi\text{D (mm)}$ \ L (mm)	50	75	80	96	100	115	120	130	155
35	A5	—	A8	—	A10	—	A12	—	—
50	—	C7	—	C9	—	C11	—	C13	—
63.5	—	—	—	D9	—	D11	—	D13	—
76	—	—	—	E9	—	E11	—	E13	E15
89	—	—	—	—	—	—	—	—	F15

◆RATED RIPPLE CURRENT MULTIPLIERS

●Frequency Multipliers

Frequency (Hz)	50	120	300	1k	3k
Coefficient	0.8	1.0	1.1	1.3	1.4

Note : The endurance of capacitors is shorted with internal heating produced by ripple current at the rate of halving the lifetime with every 5 to 10°C rise. When long life performance is required in actual use, the rms ripple current has to be reduced. Also, for the RWE series capacitors, using them at operating voltage less than their rated voltage can extend their lifetime. For the details, please contact a representative of Nippon Chemi-Con.

RWY Series

- High ripple capability
- Endurance with ripple current : 85°C 5000 hours
- Cost-down design for three-phase input inverters

RWY

low price version

RWF



SPECIFICATIONS

Items	Characteristics
Category	
Temperature Range	-25 to +85°C
Rated Voltage Range	350 to 450V _{dc}
Capacitance Tolerance	±20% (M) (at 20°C, 120Hz)
Leakage Current	I=0.02CV or 5mA, whichever is smaller. Where, I : Max. leakage current (μA), C : Nominal capacitance (μF), V : Rated voltage (V) (at 20°C after 5 minutes)
Dissipation Factor (tanδ)	0.12 max. (at 20°C, 120Hz)
Low Temperature Characteristics	Capacitance change C(-25°C)/C(+20°C)≥0.7 (at 120Hz)
Insulation Resistance	When it is measured between the terminals shorted each other and the mounting clamp on the insulating sleeve covering the case by using an insulation resistance meter of 500V _{dc} , the insulation resistance shall not be less than 100MΩ.
Insulation Withstanding Voltage	When a voltage of 2000V _{ac} is applied for 1 minute between the terminals shorted each other and the mounting clamp on the insulating sleeve covering the case, there shall not be electrical damage.
Endurance	The following specifications shall be satisfied when the capacitors are restored to 20°C after subjected to DC voltage with the rated ripple current is applied for 5000 hours at 85°C.
	Capacitance change ≤±20% of the initial value
	DF (tanδ) ≤200% of the initial specified value
	Leakage current ≤The initial specified value
Shelf Life	The following specifications shall be satisfied when the capacitors are restored to 20°C after exposing them for 1000 hours at 85°C without voltage applied.
	Capacitance change ≤±20% of the initial value
	DF (tanδ) ≤200% of the initial specified value
	Leakage current ≤The initial specified value

DIMENSIONS (Terminal Type=LGSN) [mm]

●B Type of Mounting Clamp

●C Type of Mounting Clamp

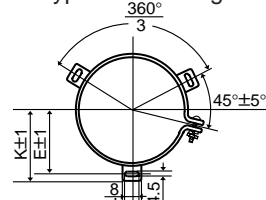
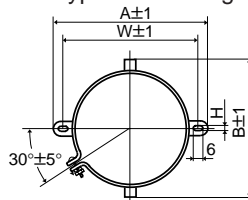
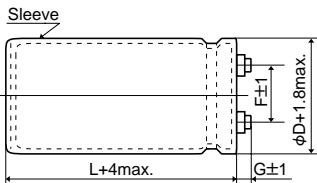

φ50 to φ76 : G=6
φ89 : G=4
φ100 : G=10

φD	A	B	W	H	F
50	78	64	68	4.5	22.4
63.5	90	76	80	4.5	28.0
76	104.5	90	93.5	4.5	31.5

φD	E	K	F	J
63.5	38.1	43.5	28.0	14.0
76	44.5	50.0	31.5	14.0
89	50.8	56.5	31.5	16.0
100	56.5	63.4	41.5	18.0

<Screw specifications>

- φ50 to φ89
- Plus hexagon-headed screw : M5×0.8×10
- Maximum screw tightening torque : 3.23Nm
- φ100
- Cross-recessed head (Phillips) screw : M8×1.25×16
- Spring washer
- Washer
- Maximum screw tightening torque : 6.31Nm

* The screw and the mounting clamp are separately supplied and not attached to the product.

PART NUMBERING SYSTEM

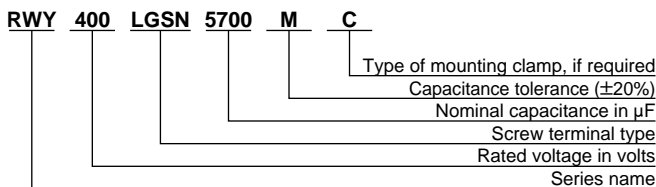

◆STANDARD RATINGS

Case size φD×L (mm)	V _{dc}		400		450	
	SV		450		500	
	Capacitance (μF) 20°C, 120Hz	Rated ripple current (Arms) 85°C, 300Hz	Capacitance (μF) 20°C, 120Hz	Rated ripple current (Arms) 85°C, 300Hz	Capacitance (μF) 20°C, 120Hz	Rated ripple current (Arms) 85°C, 300Hz
50×75	750	5.1	620	4.6	500	4.0
50×96	1,100	6.9	880	6.1	710	5.2
50×105	1,300	7.8	1,000	6.8	840	5.9
50×130	1,600	9.5	1,400	8.9	1,100	7.5
50×145	1,900	10.7	1,600	9.9	1,300	8.4
63.5×96	1,800	10.0	1,500	9.1	1,200	7.8
63.5×115	2,400	12.6	2,000	11.5	1,600	9.8
63.5×130	2,800	14.3	2,300	13.0	1,800	10.9
63.5×155	3,400	17.1	2,800	15.5	2,300	13.3
63.5×170	3,800	18.8	3,200	17.3	2,500	14.5
76×115	3,500	16.9	2,900	15.4	2,300	13.0
76×130	4,000	19.0	3,400	17.5	2,700	14.8
76×155	5,000	23.0	4,200	21.1	3,300	17.7
76×170	5,600	25.3	4,600	23.0	3,700	19.5
89×155	6,900	27.2	5,700	24.7	4,600	22.2
89×170	7,700	29.6	6,400	27.0	5,100	24.1
89×190	8,400	32.9	7,000	30.0	5,700	27.1
100×190	9,500	37.3	7,900	34.0	6,400	30.6
100×220	11,000	42.9	9,400	39.6	7,600	35.6
100×270	14,000	53.1	12,000	49.2	9,500	43.7

◆RATED RIPPLE CURRENT MULTIPLIERS
●Frequency Multipliers

Frequency (Hz)	120	300	1k	3k
Coefficient	0.83	1.0	1.25	1.33

Note : The endurance of capacitors is shorted with internal heating produced by ripple currents at the rate of halving the lifetime with every 5 to 10°C rise. When long life performance is required in actual use, the rms ripple current has to be reduced. Also, for RWY series capacitors, using them at operating voltage less than their rated voltage can extend their lifetime. For the details, please contact a representative of Nippon Chemi-Con.



LARGE CAPACITANCE ALUMINUM ELECTROLYTIC CAPACITORS Inverter-use screw terminal, 85°C

RWF Series

- High ripple capability
- Endurance with ripple current : 85°C 5000 hours
- Wide variety case sizes from $\phi 50$ to $\phi 100$

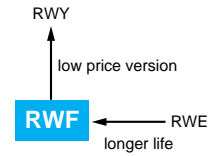

◆ SPECIFICATIONS

Items	Characteristics						
Category Temperature Range	-25 to +85°C						
Rated Voltage Range	350 to 450V _{dc}						
Capacitance Tolerance	±20% (M) (at 20°C, 120Hz)						
Leakage Current	$I = 0.02CV$ or 5mA, whichever is smaller. Where, I : Max. leakage current (μA), C : Nominal capacitance (μF), V : Rated voltage (V) (at 20°C after 5 minutes)						
Dissipation Factor (tanδ)	0.25 max. (at 20°C, 120Hz)						
Low Temperature Characteristics	Capacitance change $C(-25°C)/C(+20°C) \geq 0.7$ (at 120Hz)						
Insulation Resistance	When measured between the terminals shorted each other and the mounting clamp on the insulating sleeve covering the case by using an insulation resistance meter of 500V _{dc} , the insulation resistance shall not be less than 100MΩ.						
Insulation Withstanding Voltage	When a voltage of 2000V _{ac} is applied for 1 minute between the terminals shorted each other and the mounting clamp on the insulating sleeve covering the case, there shall not be electrical damage.						
Endurance	The following specifications shall be satisfied when the capacitors are restored to 20°C after subjected to DC voltage with the rated ripple current is applied for 5000 hours at 85°C. <table border="1" style="width: 100%;"> <tr> <td>Capacitance change</td> <td>≤ ±20% of the initial value</td> </tr> <tr> <td>DF (tanδ)</td> <td>≤ 200% of the initial specified value</td> </tr> <tr> <td>Leakage current</td> <td>≤ The initial specified value</td> </tr> </table>	Capacitance change	≤ ±20% of the initial value	DF (tanδ)	≤ 200% of the initial specified value	Leakage current	≤ The initial specified value
Capacitance change	≤ ±20% of the initial value						
DF (tanδ)	≤ 200% of the initial specified value						
Leakage current	≤ The initial specified value						
Shelf Life	The following specifications shall be satisfied when the capacitors are restored to 20°C after exposing them for 500 hours at 85°C without voltage applied. <table border="1" style="width: 100%;"> <tr> <td>Capacitance change</td> <td>≤ ±20% of the initial value</td> </tr> <tr> <td>DF (tanδ)</td> <td>≤ 200% of the initial specified value</td> </tr> <tr> <td>Leakage current</td> <td>≤ The initial specified value</td> </tr> </table>	Capacitance change	≤ ±20% of the initial value	DF (tanδ)	≤ 200% of the initial specified value	Leakage current	≤ The initial specified value
Capacitance change	≤ ±20% of the initial value						
DF (tanδ)	≤ 200% of the initial specified value						
Leakage current	≤ The initial specified value						

◆ DIMENSIONS (Terminal Type=LGSN) [mm]

● B Type of Mounting Clamp

● C Type of Mounting Clamp

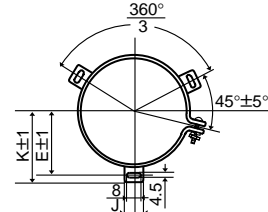
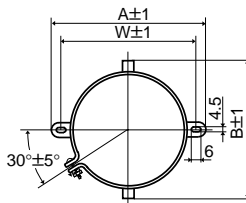
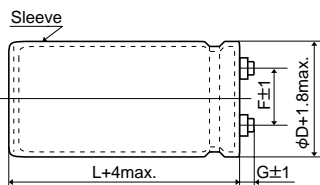

φ50 & φ63.5 : G=6
 φ76 & φ89 : G=5
 φ100 : G=10

φD	A	B	W	F
50	78	64	68	22.4
63.5	90	76	80	28.0
76	104.5	90	93.5	31.5

φD	E	K	F	J
50	32.5	37.0	22.4	14.0
63.5	38.1	43.5	28.0	14.0
76	44.5	50.0	31.5	14.0
89	50.8	56.5	31.5	16.0
100	56.5	63.4	41.5	18.0

<Screw specifications>

- φ50 to φ89
Plus hexagon-headed screw : M5×0.8×10
Maximum screw tightening torque : 3.23Nm
- φ100
Cross-recessed head (Phillips) screw : M8×1.25×16
Spring washer
Washer
Maximum screw tightening torque : 6.31Nm

* The screw and the mounting clamp are separately supplied and not attached to the product.

◆ PART NUMBERING SYSTEM

RWF 350 LGSN 10000 M C E17

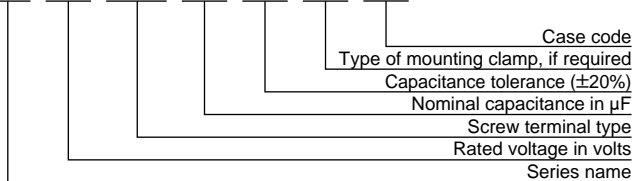

◆STANDARD RATINGS

Case size φD×L (mm)	V _{dc}		400		450		
	SV		400		500		
	Items	Capacitance (μF) 20°C, 120Hz	Rated ripple current (Arms) 85°C, 120Hz	Capacitance (μF) 20°C, 120Hz	Rated ripple current (Arms) 85°C, 120Hz	Capacitance (μF) 20°C, 120Hz	Rated ripple current (Arms) 85°C, 120Hz
50×96		2,200	7.7	1,800	7.0	1,200	5.7
						1,500	6.3
50×105				2,200	8.0		
50×115		2,700	9.3			1,800	7.6
50×130		3,300	10.8	2,700	9.8	2,200	8.8
63.5×115		3,900	12.1	3,300	11.1	2,700	10.1
63.5×130		4,700	14.0	3,900	12.7	3,300	11.7
63.5×155		5,600	16.6	4,700	15.2	3,900	13.8
63.5×190		6,800	20.0	5,600	18.2	4,700	16.7
76×115		5,600	16.1	4,700	14.7	3,900	13.4
76×130		6,800	18.6	5,600	16.9	4,700	15.5
76×155		8,200	22.2	6,800	20.2	5,600	18.3
76×170		10,000	25.2	8,200	22.8	6,800	20.7
89×155		12,000	29.1	10,000	26.6	8,200	24.1
89×170				12,000	30.0	10,000	27.8
89×190		15,000	35.7				
100×190		18,000	36.9	15,000	33.7	12,000	29.3
100×220				18,000	37.4		
100×250		22,000	46.1			15,000	37.0

◆CASE CODE

φD (mm) \ L (mm)	96	105	115	130	155	170	190	220	250
50	C9	C10R	C11	C13	—	—	—	—	—
63.5	—	—	D11	D13	D15	—	D19	—	—
76	—	—	E11	E13	E15	E17	—	—	—
89	—	—	—	—	F15	F17	F19	—	—
100	—	—	—	—	—	—	G19	G22	G25

◆RATED RIPPLE CURRENT MULTIPLIERS

●Frequency Multipliers

Frequency (Hz)	50	120	300	1k	3k
Coefficient	0.8	1.0	1.1	1.3	1.4

Note : The endurance of capacitors is shorted with internal heating produced by ripple currents at the rate of halving the lifetime with every 5 to 10°C rise. When long life performance is required in actual use, the rms ripple current has to be reduced. Also, for the RWF series capacitors, using them at operating voltage less than their rated voltage can extend their lifetime. For the details, please contact a representative of Nippon Chemi-Con.



RWL Series

- High ripple capability
- For train systems and high power consumed inverter circuits
- Endurance with ripple current : 85°C 20000 hours

RWL



◆ SPECIFICATIONS

Items	Characteristics
Category	
Temperature Range	-25 to +85°C
Rated Voltage Range	350 to 450V _{dc}
Capacitance Tolerance	±20% (M) (at 20°C, 120Hz)
Leakage Current	I = 0.02CV or 5mA, whichever is smaller. Where, I : Max. leakage current (μA), C : Nominal capacitance (μF), V : Rated voltage (V) (at 20°C after 5 minutes)
Dissipation Factor (tanδ)	0.25 max. (at 20°C, 120Hz)
Low Temperature Characteristics	Capacitance change C(-25°C)/C(+20°C) ≥ 0.7 (at 120Hz)
Insulation Resistance	When measured between the terminals shorted each other and the mounting clamp on the insulating sleeve covering the case by using an insulation resistance meter of 500V _{dc} , the insulation resistance shall not be less than 100MΩ.
Insulation Withstanding Voltage	When a voltage of 2000V _{ac} is applied for 1 minute between the terminals shorted each other and the mounting clamp on the insulating sleeve covering the case, there shall not be electrical damage.
Endurance	The following specifications shall be satisfied when the capacitors are restored to 20°C after subjected to DC voltage with the rated ripple current is applied 20000 hours at 85°C.
	Capacitance change ≤ ±30% of the initial value
	DF (tanδ) ≤ 300% of the initial specified value
	Leakage current ≤ The initial specified value
Shelf Life	The following specifications shall be satisfied when the capacitors are restored to 20°C after exposing them for 500 hours at 85°C without voltage applied.
	Capacitance change ≤ ±20% of the initial value
	DF (tanδ) ≤ 300% of the initial specified value
	Leakage current ≤ The initial specified value

◆ DIMENSIONS (Terminal Type=LGSN) [mm]

● B Type of Mounting Clamp

● C Type of Mounting Clamp

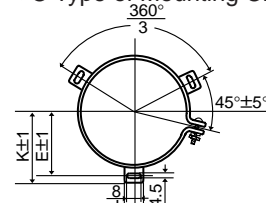
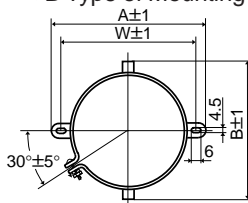
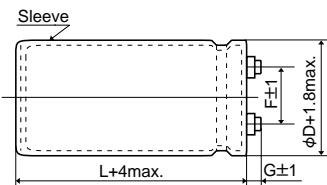

φ63.5 : G=6
φ76 & φ89 : G=5

φD	A	B	W	F
63.5	90	76	80	28.0
76	104.5	90	93.5	31.5

φD	E	K	F	J
63.5	38.1	43.5	28.0	14.0
76	44.5	50.0	31.5	14.0
89	50.8	56.5	31.5	16.0

<Screw specifications>
Plus hexagon-headed screw:
M5×0.8×10
Maximum screw tightening torque:
3.23Nm

* The screw and the mounting clamp are separately supplied and not attached to the product.

◆ PART NUMBERING SYSTEM

RWL 400 LGSN 10000 M C F19

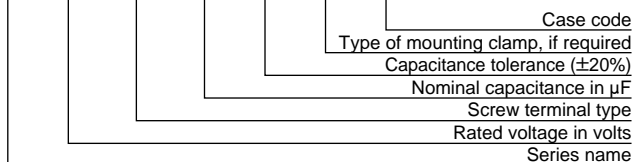



RWL Series

◆ **STANDARD RATINGS**

μF	350			400			450		
	400			450			500		
	63.5	76	89	63.5	76	89	63.5	76	89
2,200							63.5×115 9.1		
2,700				63.5×115 10.1			63.5×130 10.6	76×115 11.2	
3,300	63.5×115 11.1			63.5×130 11.7			63.5×155 12.7	76×130 13.0	
3,900	63.5×130 12.8			63.5×155 13.8	76×115 14.7		63.5×170 14.4		
4,700	63.5×155 15.2	76×115 14.7		63.5×170 15.8	76×130 15.5			76×155 16.7	
5,600	63.5×170 17.3	76×130 16.9		63.5×190 18.2	76×155 18.3			76×190 20.1	89×155 19.9
6,800	63.5×190 20.0	76×155 20.2			76×170 21.0				89×170 23.0
8,200		76×170 23.1				89×155 24.1			89×190 26.4
10,000			89×155 26.6			89×190 29.1	← Upper : Case size φD×L (mm) ← Lower : Rated ripple current (Arms) at 85°C, 120Hz		
12,000			89×190 32.0						

◆ **CASE CODE**

φD (mm)	L (mm)	115	130	155	170	190
63.5		D11	D13	D15	D17	D19
76		E11	E13	E15	E17	E19
89		—	—	F15	F17	F19

◆ **RATED RIPPLE CURRENT MULTIPLIERS**

● Frequency Multipliers

Frequency (Hz)	50	120	300	1k	3k
Coefficient	0.8	1.0	1.1	1.3	1.4

Note : The endurance of capacitors is shortened with internal heating produced by ripple currents at the rate of halving the lifetime with every 5 to 10°C rise. When long life performance is required in actual use, the rms ripple current has to be reduced. Also, for RWL series capacitors, using them at operating voltage less than their rated voltage can extend their lifetime. For the details, please contact a representative of Nippon Chemi-Con.

Upgrade!

LXA Series

- Newly line-uped up to 525V_{dc}
- Load life with ripple current : 105°C 5000 hours (2000 hours for 500V_{dc} & 525V_{dc})
- High reliability products



◆ SPECIFICATIONS

Items	Characteristics												
Category													
Temperature Range	-40 to +105°C (10 to 100V _{dc}) -25 to +105°C (160 to 525V _{dc})												
Rated Voltage Range	10 to 525V _{dc}												
Capacitance Tolerance	-10 to +50% (T) (10 to 250V _{dc}) ±20% (M) (350 to 525V _{dc}) (at 20°C, 120Hz)												
Leakage Current	I=0.02CV or 5mA, whichever is smaller. Where, I : Max. leakage current (μA), C : Nominal capacitance (μF), V : Rated voltage (V) (at 20°C after 5 minutes)												
Dissipation Factor (tanδ)	See STANDARD RATINGS (10 to 250V _{dc}) 0.20max (350 to 525V _{dc}) (at 20°C, 120Hz)												
Low Temperature Characteristics	Capacitance change C(-40°C)/C(+20°C)≥0.6(10 to 100V _{dc}) C(-25°C)/C(+20°C)≥0.7(160 to 250V _{dc}) C(-25°C)/C(+20°C)≥0.65(350 to 525V _{dc}) (at 120Hz)												
Insulation Resistance	When measured between the terminals shorted each other and the mounting clamp on the insulating sleeve covering the case by using an insulation resistance meter of 500V _{dc} , the insulation resistance shall not be less than 100MΩ.												
Insulation Withstanding Voltage	When a voltage of 2000Vac is applied for 1 minute between the terminals shorted each other and the mounting clamp on the insulating sleeve covering the case, there shall not be electrical damage.												
Endurance	The following specifications shall be satisfied when the capacitors are restored to 20°C after DC voltage with the rated ripple current is applied for 5000 hours (2000 hours for 500 & 525V _{dc} products) at 105°C. <table border="1"> <tr> <td>Capacitance change</td> <td>≤±20% of the initial value</td> </tr> <tr> <td>DF (tanδ)</td> <td>≤200% of the initial specified value</td> </tr> <tr> <td>Leakage current</td> <td>≤The initial specified value</td> </tr> </table>	Capacitance change	≤±20% of the initial value	DF (tanδ)	≤200% of the initial specified value	Leakage current	≤The initial specified value						
Capacitance change	≤±20% of the initial value												
DF (tanδ)	≤200% of the initial specified value												
Leakage current	≤The initial specified value												
Shelf Life	The following specifications shall be satisfied when the capacitors are restored to 20°C after exposing them for 500 hours at 105°C without voltage applied. <table border="1"> <tr> <td>Rated voltage</td> <td>10 to 250V_{dc}</td> <td>350 to 525V_{dc}</td> </tr> <tr> <td>Capacitance change</td> <td>≤±15% of the initial value</td> <td>≤±20% of the initial value</td> </tr> <tr> <td>DF (tanδ)</td> <td>≤150% of the initial specified value</td> <td>≤200% of the initial specified value</td> </tr> <tr> <td>Leakage current</td> <td>≤The initial specified value</td> <td>≤The initial specified value</td> </tr> </table>	Rated voltage	10 to 250V _{dc}	350 to 525V _{dc}	Capacitance change	≤±15% of the initial value	≤±20% of the initial value	DF (tanδ)	≤150% of the initial specified value	≤200% of the initial specified value	Leakage current	≤The initial specified value	≤The initial specified value
Rated voltage	10 to 250V _{dc}	350 to 525V _{dc}											
Capacitance change	≤±15% of the initial value	≤±20% of the initial value											
DF (tanδ)	≤150% of the initial specified value	≤200% of the initial specified value											
Leakage current	≤The initial specified value	≤The initial specified value											

◆ DIMENSIONS (Terminal Type=LGSN) [mm]

● B Type of Mounting Clamp

● C Type of Mounting Clamp

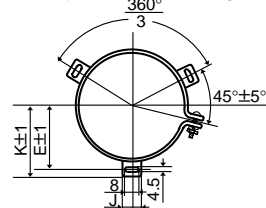
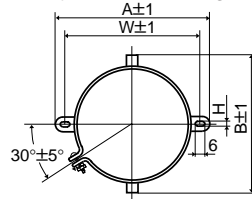
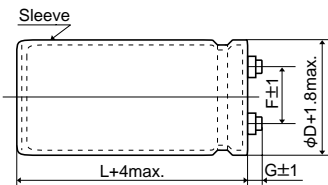

φD	A	B	W	H	F
35	58	44	48	3.5	12.7
50	78	64	68	4.5	22.4
63.5	90	76	80	4.5	28.0
76	104.5	90	93.5	4.5	31.5

φD	E	K	J	F
50	32.5	37.0	14.0	22.4
63.5	38.1	43.5	14.0	28.0
76	44.5	50.0	14.0	31.5
89	50.8	56.5	16.0	31.5

<Screw specifications>

Plus hexagon-headed screw:
M5×0.8×10

Maximum screw tightening torque:
3.23Nm

φ35 to φ63.5 : G=6

φ76 & φ89 : G=5

* The screw and the mounting clamp are separately supplied and not attached to the product.

◆ PART NUMBERING SYSTEM

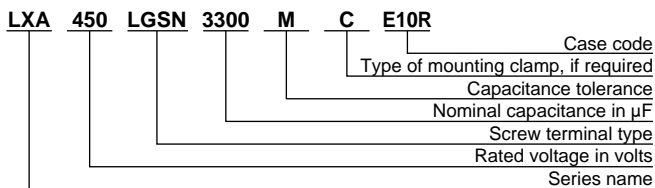

◆ CASE CODE

φD (mm)	L (mm)	50	60	80	85	100	105	120	125	140	145	190	270
35	A5	—	A8	—	A10	—	A12	—	—	—	—	—	—
50	—	C6	C8	C8R	C10	C10R	C12	C12R	—	C14R	—	—	—
63.5	—	—	—	D8R	D10	D10R	D12	D12R	—	D14R	—	—	—
76	—	—	—	E8R	E10	E10R	E12	E12R	E14	E14R	E19	—	—
89	—	—	—	—	—	—	—	F12R	F14	F14R	F19	F27	—



Upgrade!

LXA Series

◆ STANDARD RATINGS

μF	V _{dc}		10			16			25			35			50			63			80		
	SV		13			20			32			44			63			79			100		
2,200																					A 5	1.9	0.15
2,700																					A 5	1.9	0.15
3,300																					A 5	2.1	0.15
3,900																					A 8	2.7	0.20
4,700																					A 8	2.9	0.20
5,600																					A 8	3.2	0.20
6,800																					A 8	3.5	0.20
8,200																					A 10	4.2	0.20
10,000																					A 8	3.0	0.30
12,000																					A 8	3.3	0.30
15,000																					A 8	3.6	0.30
18,000																					A 10	4.4	0.25
22,000																					A 12	5.2	0.35
27,000																					C 10	5.9	0.35
33,000																					C 12	7.0	0.35
39,000																					D 12	8.8	0.30
47,000																					E 10	10.0	0.30
56,000																					E 12	10.7	0.35
68,000																					F 14	12.5	0.35
82,000																							
100,000																							
120,000																							
150,000																							
180,000																							
220,000																							
270,000																							
330,000																							
390,000																							

Case code
 Rated ripple current (Arms) at 105°C, 120Hz
 Max. tanδ at 20°C, 120Hz

μF	V _{dc}		100			160			200			250		
	SV		125			200			250			300		
330												A 5	0.7	0.15
390												A 8	0.8	0.15
470												A 5	0.9	0.15
560												A 8	1.0	0.15
680												A 8	1.1	0.15
820												A 10	1.2	0.15
1,000												A 8	1.3	0.15
1,200												A 10	1.5	0.15
1,500												A 12	1.6	0.15
1,800												C 8	1.8	0.15
2,200												C 10	2.2	0.15
2,700												C 12	2.6	0.15
3,300												C 12	2.8	0.15
3,900												D 10	3.3	0.15
4,700												D 12	4.0	0.15
5,600												E 10	4.4	0.15
6,800												E 12	5.2	0.15
8,200												E 14	6.1	0.15
10,000												F 14	7.4	0.15
12,000														
15,000														
18,000														
22,000														
27,000														

Max. tanδ at 20°C, 120Hz
 Rated ripple current (Arms) at 105°C, 120Hz
 Case code

◆STANDARD RATINGS

Case size φDXL (mm)	V _{dc}		400		450	
	SV		400		500	
	Items	Capacitance (μF) 20°C, 120Hz	Rated ripple current (Arms) 105°C, 120Hz	Capacitance (μF) 20°C, 120Hz	Rated ripple current (Arms) 105°C, 120Hz	Capacitance (μF) 20°C, 120Hz
50×60	820	3.3	680	3.0	560	2.6
50×85	1,500	5.2	1,200	4.7	1,000	4.0
50×105	2,200	7	1,800	6.3	1,200	4.8
50×125	2,700	8.4	2,200	7.5	1,800	6.4
50×145	3,300	9.9	2,700	8.9	2,200	7.6
63.5×85	2,700	8.1	2,200	7.3	1,800	6.2
63.5×105	3,300	9.8	2,700	8.6	2,200	7.5
63.5×125	3,900	11.5	3,300	10.5	2,700	8.9
63.5×145	5,600	14.7	4,700	13.4	3,300	10.6
76.2×85	3,900	10.8	3,300	9.9	2,700	8.4
76.2×105					3,300	10.2
76.2×125	6,800	16.8	4,700	13.9	3,900	10.9
76.2×145	8,200	19.6	6,800	17.9	4,700	14
76.2×190	1,000	24.5	8,200	20.8	6,800	17.3
89×125	8,200	18.9	6,800	17.2	5,600	14.2
89×145	10,000	22.2	8,200	20.1	6,800	16.7
89×190	15,000	30.6	12,000	27.4	10,000	22.8
89×270	22,000	43.5	18,000	39.4	15,000	32.8

Case size φDXL (mm)	V _{dc}		500		525	
	SV		550		575	
	Items	Capacitance (μF) 20°C, 120Hz	Rated ripple current (Arms) 105°C, 120Hz	Capacitance (μF) 20°C, 120Hz	Rated ripple current (Arms) 105°C, 120Hz	Capacitance (μF) 20°C, 120Hz
50×60	470	2.4	390	2.2		
50×85	820	3.6	680	3.3		
50×105	1,000	4.4				
50×125	1,200	5.2	1,000	4.8		
50×145	1,500	6.3				
63.5×85	1,200	5.0				
63.5×105	1,800	6.8	1,500	6.2		
63.5×125			1,800	7.3		
63.5×145	2,700	9.6	2,200	8.6		
76.2×85						
76.2×105	2,700	9.2	2,200	8.3		
76.2×125			2,700	9.9		
76.2×145	3,900	12.7	3,300	11.7		
76.2×190			4,700	14.4		
89×125	3,900	11.9				
89×145			4,700	13.9		
89×190	6,800	18.8	5,600	17.1		
89×270	10,000	26.8				



Upgrade!

LXASeries

◆RATED RIPPLE CURRENT MULTIPLIERS

●Frequency Multipliers

(10 to 250V_{dc})

Frequency (Hz)	50	120	300	1k	10k	50k
10 to 50V_{dc}	0.95	1.00	1.03	1.05	1.09	1.12
63 to 80V_{dc}	0.90	1.00	1.06	1.10	1.18	1.22
100 to 250V_{dc}	0.80	1.00	1.12	1.22	1.30	1.33

(350 to 525V_{dc})

Frequency (Hz)	120	300	1k	3k
Coefficient	1.0	1.2	1.5	1.6

Note : The endurance of capacitors is shortened with internal heating produced by ripple currents at the rate of halving the lifetime with every 5 to 10°C rise. When long life performance is requested in actual use, the rms ripple current has to be reduced. Also, for the LXA series capacitors (350 to 525V_{dc} products), using them at operating voltage can extend their lifetime. For the detail, please contact a representative of Nippon Chemi-con.



LARGE CAPACITANCE ALUMINUM ELECTROLYTIC CAPACITORS Inverter-use screw terminal, 105°C

LX Series

●Endurance with ripple current : 105°C 5000 hours

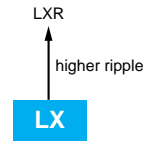

◆SPECIFICATIONS

Items	Characteristics	
Category		
Temperature Range	-25 to +105°C	
Rated Voltage Range	350 to 450V _{dc}	
Capacitance Tolerance	±20% (M) (at 20°C, 120Hz)	
Leakage Current	I=0.02CV or 5mA, whichever is smaller. Where, I : Max. leakage current (μA), C : Nominal capacitance (μF), V : Rated voltage (V) (at 20°C after 5 minutes)	
Dissipation Factor (tanδ)	0.25 max. (at 20°C, 120Hz)	
Low Temperature Characteristics	Capacitance change $C(-25°C)/C(+20°C) \geq 0.7$ (at 120Hz)	
Insulation Resistance	When measured between the terminals shorted each other and the mounting clamp on the insulating sleeve covering the case by using an insulation resistance meter of 500V _{dc} , the insulation resistance shall not be less than 100MΩ.	
Insulation Withstanding Voltage	When a voltage of 2000V _{ac} is applied for 1 minute between the terminals shorted each other and the mounting clamp on the insulating sleeve covering the case, there shall not be electrical damage.	
Endurance	The following specifications shall be satisfied when the capacitors are restored to 20°C after subjected to DC voltage with the rated ripple current is applied for 5000 hours at 105°C.	
	Capacitance change	≤±30% of the initial value
	DF (tanδ)	≤300% of the initial specified value
	Leakage current	≤The initial specified value
Shelf Life	The following specifications shall be satisfied when the capacitors are restored to 20°C after exposing them for 500 hours at 105°C without voltage applied.	
	Capacitance change	≤±20% of the initial value
	DF (tanδ)	≤300% of the initial specified value
	Leakage current	≤The initial specified value

◆DIMENSIONS (Terminal Type=LGSN) [mm]

●B Type of Mounting Clamp

●C Type of Mounting Clamp

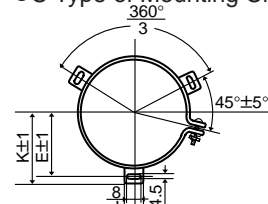
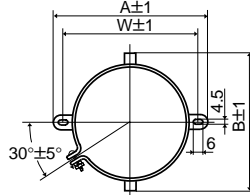
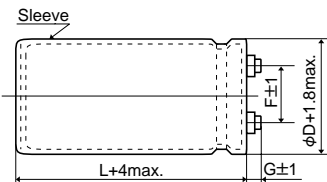

φD	A	B	W	F
63.5	90	76	80	28.0
76	104.5	90	93.5	31.5

φD	E	K	J	F
63.5	38.1	43.5	14.0	28.0
76	44.5	50.0	14.0	31.5
89	50.8	56.5	16.0	31.5

<Screw specifications>
 Plus hexagon-headed screw:
 M5×0.8×10
 Maximum screw tightening torque:
 3.23Nm

φ63.5 : G=6

φ76 & φ89 : G=5

* The screw and the mounting clamp are separately supplied and not attached to the product.

◆PART NUMBERING SYSTEM

LX 350 LGSN 10000 M C F15

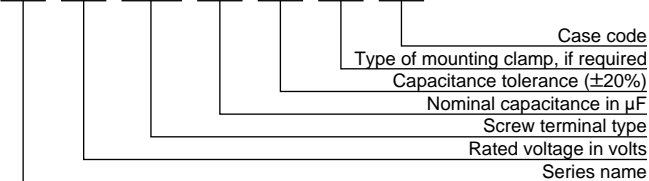

◆STANDARD RATINGS

μF	350			400			450			
	400			450			500			
	63.5	76	89	63.5	76	89	63.5	76	89	
2,200							63.5×115 7.0			
2,700				63.5×115 7.8			63.5×130 8.2	76×115 8.6		
3,300	63.5×115 8.5			63.5×130 9.0			63.5×155 9.8	76×130 10.0		
3,900	63.5×130 9.8			63.5×155 10.6	76×115 11.7		63.5×170 11.1			
4,700	63.5×155 11.7	76×115 11.3		63.5×170 12.2	76×130 11.9			76×155 12.8		
5,600	63.5×170 13.3	76×130 13.0		63.5×190 14.0	76×155 14.0			76×190 15.4	89×155 15.3	
6,800	63.5×190 15.4	76×155 15.5			76×170 16.2				89×170 17.7	
8,200		76×170 17.8				89×155 18.5			89×190 20.3	
10,000			89×155 20.5			89×190 22.4				
12,000			89×190 24.6	← Upper : Case size φD×L (mm) ← Lower : Rated ripple current (Arms) at 105°C, 120Hz						

◆CASE CODE

φD (mm)	L (mm)	115	130	155	170	190
63.5		D11	D13	D15	D17	D19
76		E11	E13	E15	E17	E19
89		—	—	F15	F17	F19

◆RATED RIPPLE CURRENT MULTIPLIERS
●Frequency Multipliers

Frequency (Hz)	50	120	300	1k	3k
Coefficient	0.8	1.0	1.1	1.3	1.4

Note : The endurance of capacitors is shorted with internal heating produced by ripple currents at the rate of halving the lifetime with every 5 to 10°C rise. When long life performance is required in actual use, the rms ripple current has to be reduced. Also, for the LX series capacitors, using them at operating voltage less than their rated voltage can extend their lifetime. For the details, please contact a representative of Nippon Chemi-Con.

LXR Series

- Higher ripple capability than LX series
- Endurance with ripple current : 105°C 5000 hours

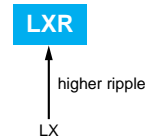

◆ SPECIFICATIONS

Items	Characteristics						
Category							
Temperature Range	-25 to +105°C						
Rated Voltage Range	350 to 450V _{dc}						
Capacitance Tolerance	±20% (M) (at 20°C, 120Hz)						
Leakage Current	I=0.02CV or 5mA, whichever is smaller. Where, I : Max. leakage current (μA), C : Nominal capacitance (μF), V : Rated voltage (V) (at 20°C after 5 minutes)						
Dissipation Factor (tanδ)	0.15max. (at 20°C, 120Hz)						
Low Temperature Characteristics	Capacitance change C (-25°C)/C(+20°C)≥0.7 (at 120Hz)						
Insulation Resistance	When measured between the terminals shorted each other and the mounting clamp on the insulating sleeve covering the case by using an insulation resistance meter of 500Vdc, the insulation shall not be less than 100MΩ.						
Insulation Withstanding Voltage	When a voltage of 2000Vac is applied for 1 minute between the terminals shorted each other and the mounting clamp on the insulating sleeve covering the case, there shall not be electrical damage.						
Endurance	The following specifications shall be satisfied when the capacitors are restored to 20°C after subjected to DC voltage with the rated ripple current is applied for 5000 hours at 105°C. <table border="1"> <tr> <td>Capacitance change</td> <td>≤±20% of the initial value</td> </tr> <tr> <td>DF (tanδ)</td> <td>≤200% of the initial specified value</td> </tr> <tr> <td>Leakage current</td> <td>≤The initial specified value</td> </tr> </table>	Capacitance change	≤±20% of the initial value	DF (tanδ)	≤200% of the initial specified value	Leakage current	≤The initial specified value
Capacitance change	≤±20% of the initial value						
DF (tanδ)	≤200% of the initial specified value						
Leakage current	≤The initial specified value						
Shelf Life	The following specifications shall be satisfied when the capacitors are restored to 20°C after exposing them for 1000 hours at 105°C without voltage applied. <table border="1"> <tr> <td>Capacitance change</td> <td>≤±20% of the initial value</td> </tr> <tr> <td>DF (tanδ)</td> <td>≤200% of the initial specified value</td> </tr> <tr> <td>Leakage current</td> <td>≤The initial specified value</td> </tr> </table>	Capacitance change	≤±20% of the initial value	DF (tanδ)	≤200% of the initial specified value	Leakage current	≤The initial specified value
Capacitance change	≤±20% of the initial value						
DF (tanδ)	≤200% of the initial specified value						
Leakage current	≤The initial specified value						

◆ DIMENSIONS (Terminal Type=LGSN) [mm]

● B Type of Mounting Clamp

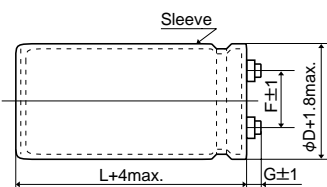

φ63.5 & φ76 : G=6
φ89 : G=4
φ100 : G=10

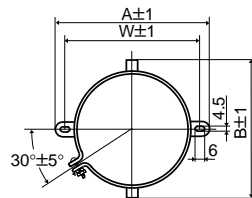

φD	A	B	W	F
63.5	90	76	80	28.0
76	104.5	90	93.5	31.5

● C Type of Mounting Clamp

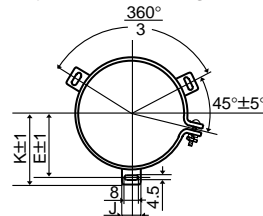

φD	E	K	F	J
63.5	38.1	43.5	28.0	14.0
76	44.5	50.0	31.5	14.0
89	50.8	56.5	31.5	16.0
100	56.5	63.4	41.5	18.0

<Screw specifications>

φ63.5 to φ89

Plus hexagon-headed screw :

M5×0.8×10

Maximum screw tightening torque :

3.23Nm

φ100

Cross-recessed head (Phillips) screw :

M8×1.25×16

Spring washer

Washer

Maximum screw tightening torque :

6.31Nm

* The screw and the mounting clamp are separately supplied and not attached to the product.

◆ PART NUMBERING SYSTEM

LXR 400 LGSN 10000 M C G19

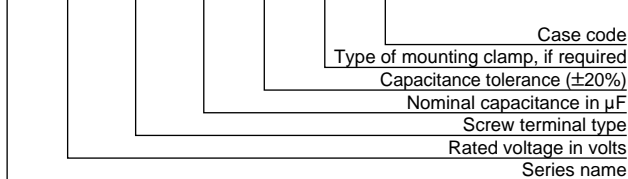



LXRSeries

◆ **STANDARD RATINGS**

μF	350				400				450				
	400				450				500				
	63.5	76	89	100	63.5	76	89	100	63.5	76	89	100	
2,200									63.5×115 11.8				
2,700					63.5×115 13.1				63.5×130 13.7	76×115 14.5			
3,300	63.5×115 14.4				63.5×130 15.2				63.5×155 16.5	76×130 16.9			
3,900	63.5×130 16.6				63.5×155 17.9	76×115 18.2			63.5×170 18.7				
4,700	63.5×155 19.8	76×115 19.1			63.5×170 20.5	76×130 20.1				76×155 21.7			
5,600	63.5×170 22.5	76×130 21.9				76×155 23.8				76×190 26.1	89×155 24.1		
6,800		76×155 26.2				76×170 27.3	89×155 26.6				89×170 27.8		
8,200		76×170 30.0	89×155 29.2				89×170 30.5				89×190 32.0		
10,000			89×170 33.7					100×190 34.5				100×220 36.8	
12,000				100×190 37.8				100×220 40.2				100×250 42.7	
15,000				100×250 47.7	← Upper : Case size φD×L (mm) ← Lower : Rated ripple current (Arms) at 105°C, 120Hz								

◆ **CASE CODE**

φD (mm)	L (mm)	115	130	155	170	190	220	250
63.5		D11	D13	D15	D17	—	—	—
76		E11	E13	E15	E17	E19	—	—
89		—	—	F15	F17	F19	—	—
100		—	—	—	—	G19	G22	G25

◆ **RATED RIPPLE CURRENT MULTIPLIERS**

● Frequency Multipliers

Frequency (Hz)	120	300	1k	3k
Coefficient	1.0	1.1	1.3	1.4

The endurance of capacitors is shortened with internal heating produced by ripple current at the rate of halving the lifetime with every 5 to 10°C rise. When long life performance is required in actual use, the rms ripple current has to be reduced. Also, for the LXR series capacitors, using them at operating voltage less than their rated voltage can extend their lifetime. For the details, please contact a representative of Nippon Chemi-Con.

KW Series

- Low ESR and impedance at high frequency (10k to 50kHz)
- Endurance : 105°C 2000 hours



◆ SPECIFICATIONS

Items	Characteristics				
Category Temperature Range	-40 to +105°C				
Rated Voltage Range	10 to 100V _{dc}				
Capacitance Tolerance	-10 to +50% (T) (at 20°C, 120Hz)				
Leakage Current	I=0.02CV or 5mA, whichever is smaller. Where, I : Max. leakage current (μA), C : Nominal capacitance (μF), V : Rated voltage (V) (at 20°C after 5 minutes)				
Dissipation Factor (tanδ)	Shall not exceed the values shown in the STANDARD RATINGS (at 20°C, 120Hz)				
Low Temperature Characteristics	Capacitance change : C(-40°C)/C(+20°C) ≥ 0.6 (at 120Hz)				
	Z(-10°C)/Z(+20°C)	<table border="1"> <tr> <td>10 & 16V_{dc}</td> <td>8 max.</td> </tr> <tr> <td>25 to 100V_{dc}</td> <td>6 max.</td> </tr> </table> (at 20kHz)	10 & 16V _{dc}	8 max.	25 to 100V _{dc}
10 & 16V _{dc}	8 max.				
25 to 100V _{dc}	6 max.				
Insulation Resistance	When measured between the terminals shorted each other and the mounting clamp on the insulating sleeve covering the case by using an insulation resistance meter of 500V _{dc} , the insulation resistance shall not be less than 100MΩ.				
Insulation Withstanding Voltage	When a voltage of 2000Vac is applied for 1 minute between the terminals shorted each other and the mounting clamp on the insulating sleeve covering the case, there shall not be electrical damage.				
Endurance	The following specifications shall be satisfied when the capacitors are restored to 20°C after the rated voltage is applied for 2000 hours at 105°C.				
	Capacitance change	≤ ±20% of the initial value			
	DF (tanδ)	≤ 200% of the initial specified value			
	Leakage current	≤ The initial specified value			
Shelf Life	The following specifications shall be satisfied when the capacitors are restored to 20°C after exposing them for 500 hours at 105°C without voltage applied.				
	Capacitance change	≤ ±15% of the initial value			
	DF (tanδ)	≤ 175% of the initial specified value			
	Leakage current	≤ The initial specified value			

◆ DIMENSIONS (Terminal Type=LGSN) [mm]

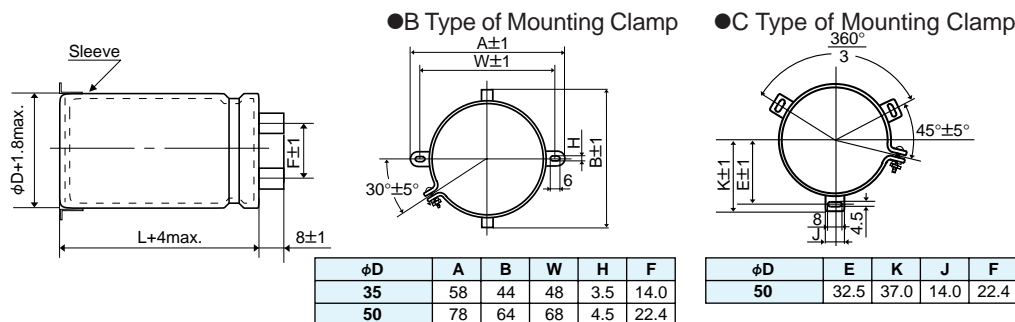

* The screw and the mounting clamp are separately supplied and not attached to the product.

◆ PART NUMBERING SYSTEM

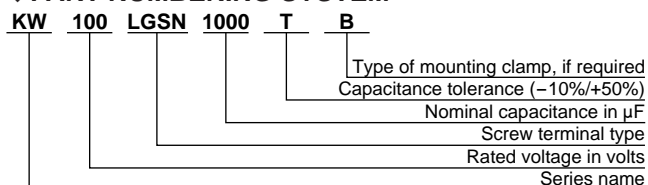

◆STANDARD RATINGS

Rated voltage (V _{dc})	Surge voltage (V _{dc})	Capacitance (μF)	Part number	Case size φDXL (mm)	Rated ripple (Arms85°C, 20kHz)	Impedance (mΩ20°C, 20kHz)	Dissipation factor
10	13	10,000	KW10LGSN10000T	35×50	10.2	12	0.20
		22,000	KW10LGSN22000T	35×80	14.0	8	0.20
		33,000	KW10LGSN33000T	35×80	17.1	7	0.25
		47,000	KW10LGSN47000T	35×100	19.9	6	0.25
		100,000	KW10LGSN100000T	50×120	28.9	5	0.30
16	20	10,000	KW16LGSN10000T	35×50	10.2	12	0.20
		22,000	KW16LGSN22000T	35×80	14.0	8	0.20
		33,000	KW16LGSN33000T	35×100	18.6	8	0.20
		47,000	KW16LGSN47000T	50×80	23.2	6	0.25
25	32	10,000	KW25LGSN10000T	35×80	12.9	10	0.17
		22,000	KW25LGSN22000T	35×100	15.2	8	0.17
		33,000	KW25LGSN33000T	50×80	21.7	6	0.20
35	44	4,700	KW35LGSN4700T	35×50	8.4	16	0.15
		10,000	KW35LGSN10000T	35×80	12.9	10	0.15
		22,000	KW35LGSN22000T	50×80	19.4	7	0.15
50	63	3,300	KW50LGSN3300T	35×50	8.4	15	0.13
		4,700	KW50LGSN4700T	35×80	12.1	10	0.13
		10,000	KW50LGSN10000T	35×100	15.2	8	0.13
63	79	2,200	KW63LGSN2200T	35×50	7.7	18	0.12
		3,300	KW63LGSN3300T	35×80	10.8	12	0.12
		4,700	KW63LGSN4700T	35×80	12.1	10	0.12
		10,000	KW63LGSN10000T	50×80	17.7	7	0.12
80	100	2,200	KW80LGSN2200T	35×80	9.9	14	0.10
		3,300	KW80LGSN3300T	35×80	11.4	12	0.10
		4,700	KW80LGSN4700T	35×100	14.0	8	0.10
100	125	1,000	KW100LGSN1000T	35×50	7.2	22	0.10
		2,200	KW100LGSN2200T	35×80	9.9	14	0.10
		3,300	KW100LGSN3300T	35×100	12.4	11	0.10

◆RATED RIPPLE CURRENT MULTIPLIERS

●Frequency Multipliers

Rated Voltage (V _{dc})	Case size	Frequency (Hz)				
		50	120	1k	20k	50k
10 & 16	φ35 & φ50	0.75	0.84	0.96	1.00	1.01
25 to 50	φ35	0.68	0.81	0.95	1.00	1.01
25 to 63	φ50					
63 to 100	φ35	0.56	0.75	0.94	1.00	1.01

●Temperature Multipliers

Temperature (°C)	85	105
Coefficient	1.00	0.57

NP-CAP®PX Series

● **Temperature Characteristics**

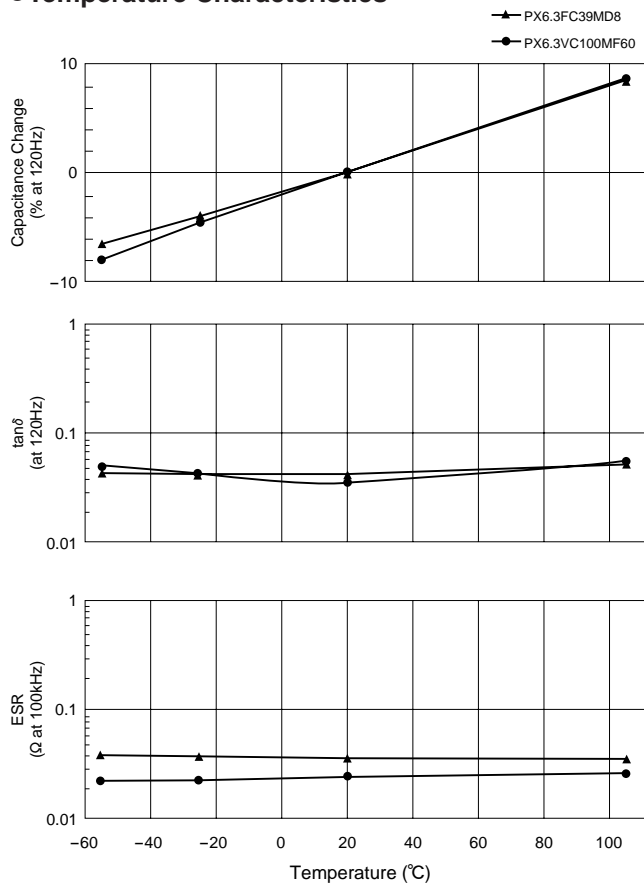

● **Impedance/ESR-Frequency Characteristics**

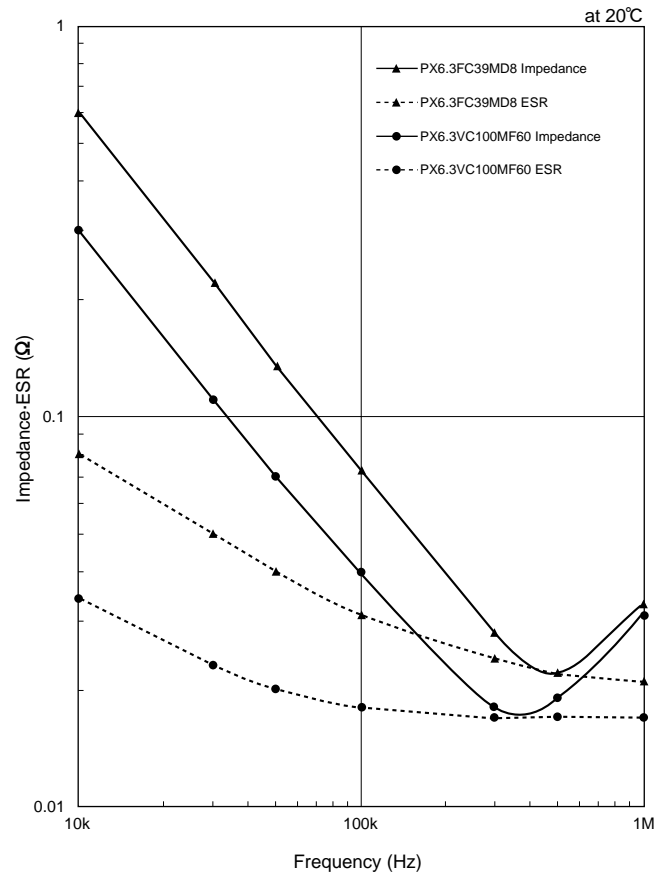

● **105°C Endurance**

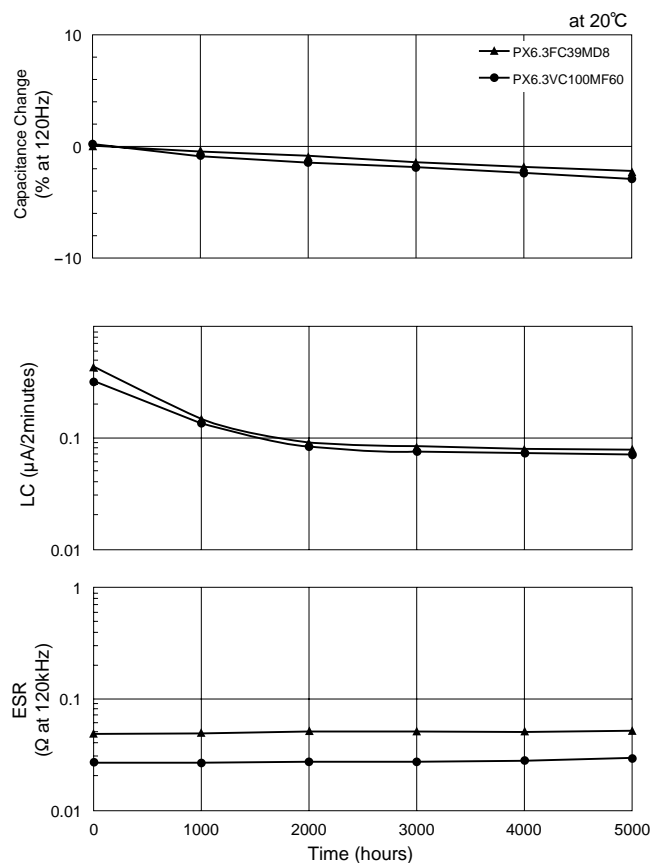

● **Reflow Soldering Characteristics**

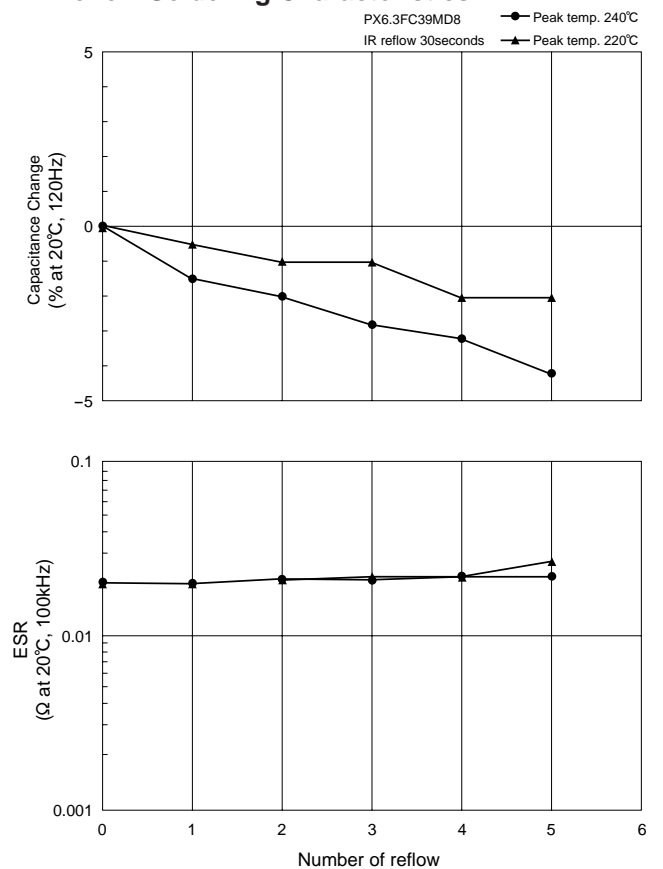

● Temperature Characteristics (-55 to +105°C)

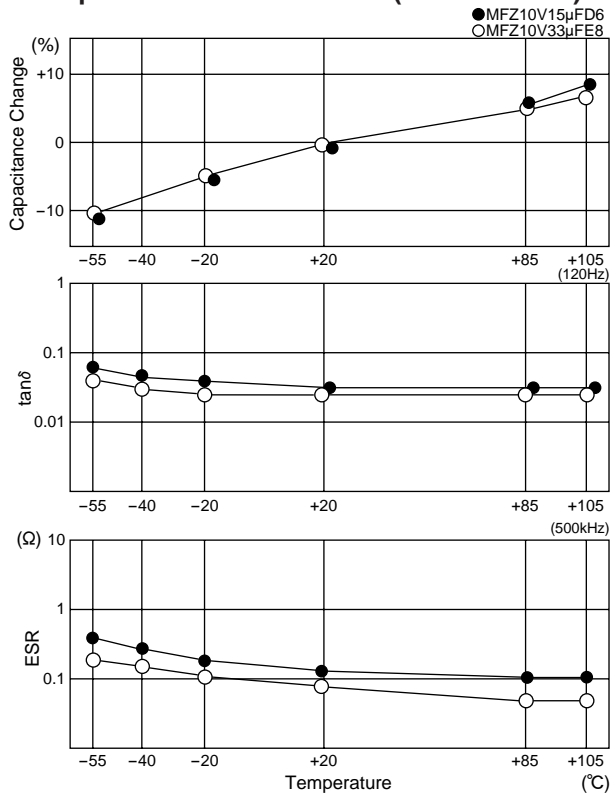

● Impedance-Frequency Characteristics

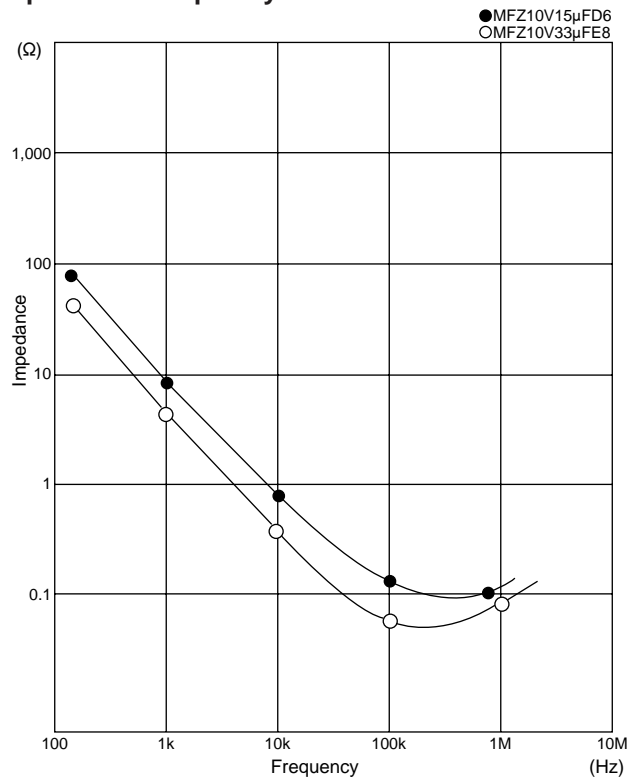

● 105°C Endurance

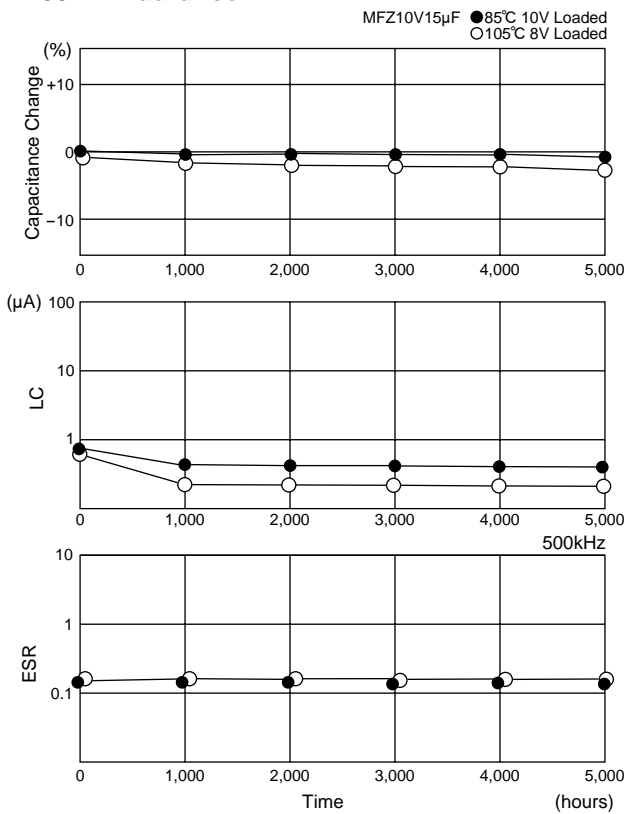

● Reflow Soldering Characteristics

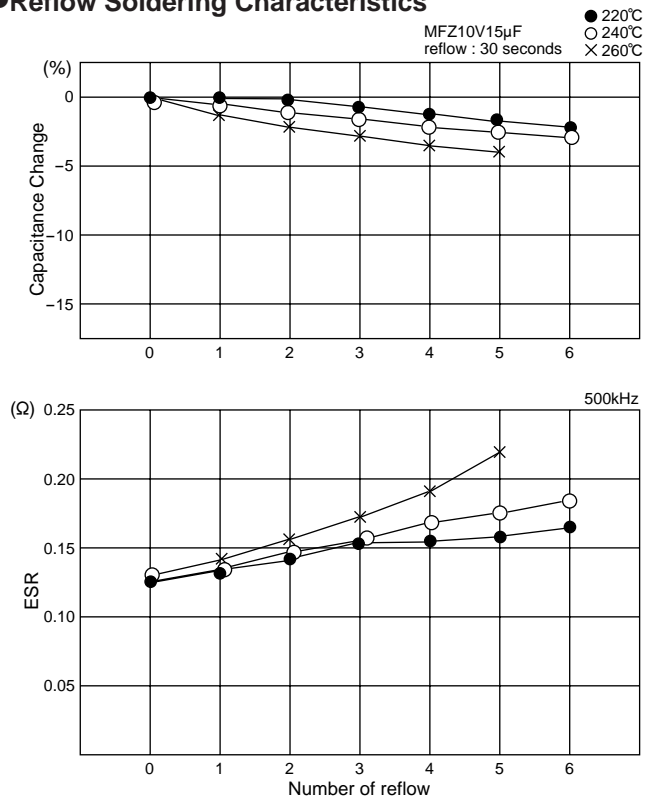

Alchip® MF/MFJ Series

●MF series 85°C Endurance/Shelf Life

○MF6.3FC10M A6/6.3V10μF
 △MF16FC10M B6/16V10μF
 ×MF10FC22M C6/10V22μF
 ●MF50FC15M D13/50V15μF

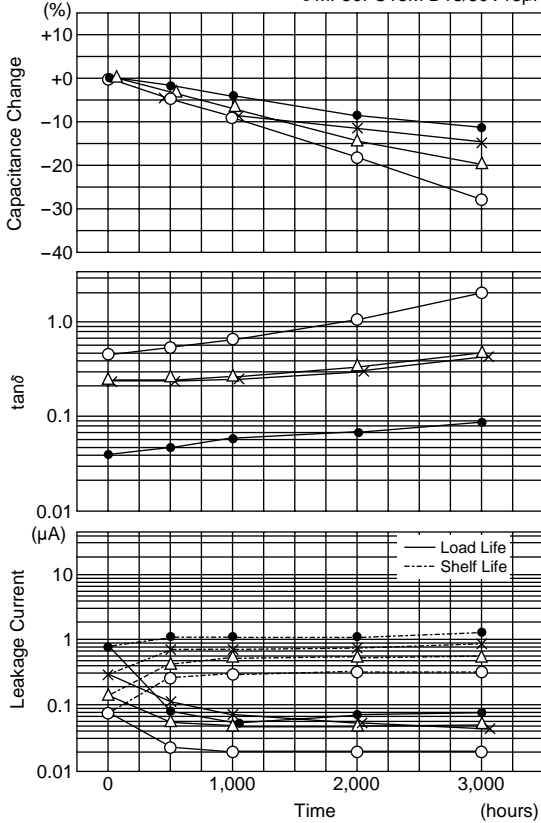

●MFJ series 105°C Endurance

○MFJ 16VC 10M D6/16V 10μF
 ●MFJ 16VC 47M D13/16V 47μF
 △MFJ6.3VC100M D13/6.3V 100μF

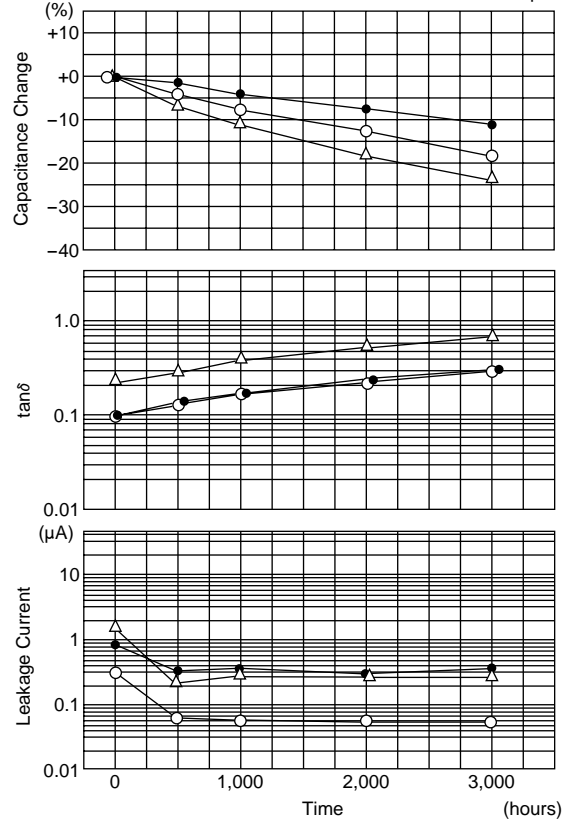

◆MF Series Terminal Strength Test

●Without Dummy Terminal : Type FC

①Bent Test <Fig-1>

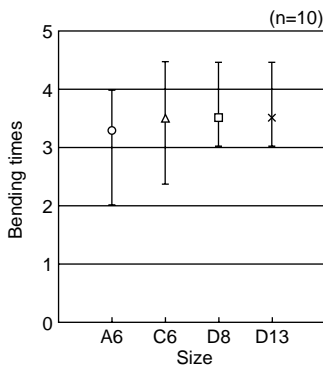

②Mechanical Force to Lead Facing Side <Fig-2>

Size	Mechanical Force (n=10)
A6	≥5N
C6	≥5N
D8	≥5N
D13	≥5N

*No peeling off terminal.

●With Dummy Terminal : Type FD

①Mechanical Force to Side <Fig-3>

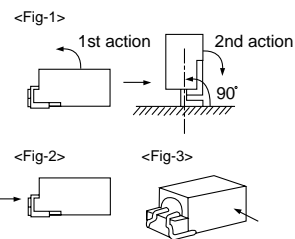
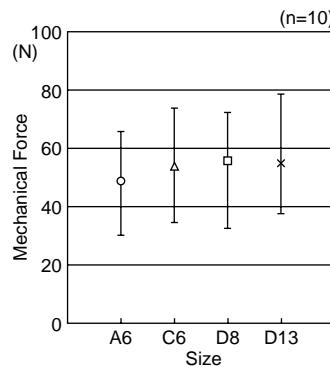

MVJ Series

MVH Series

●105°C Endurance

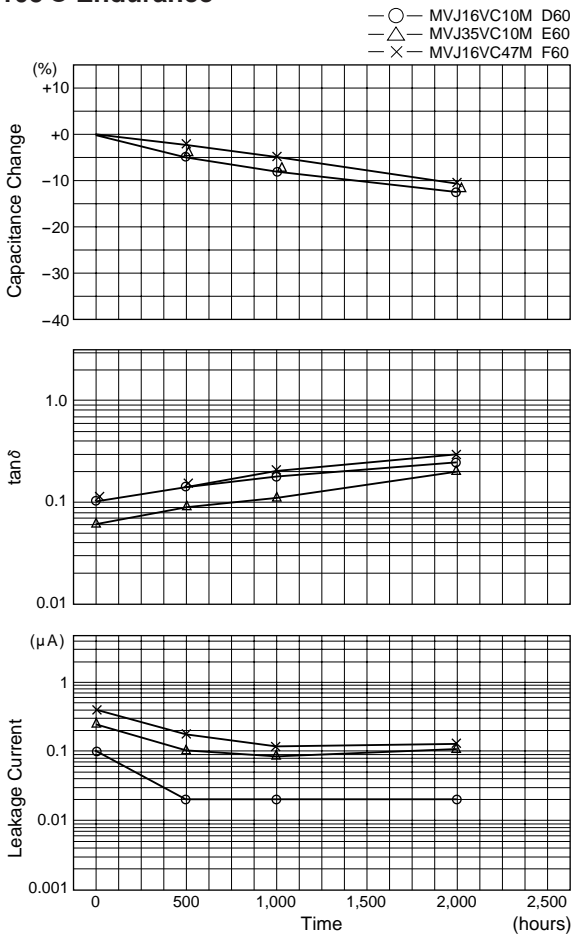

●125°C Endurance

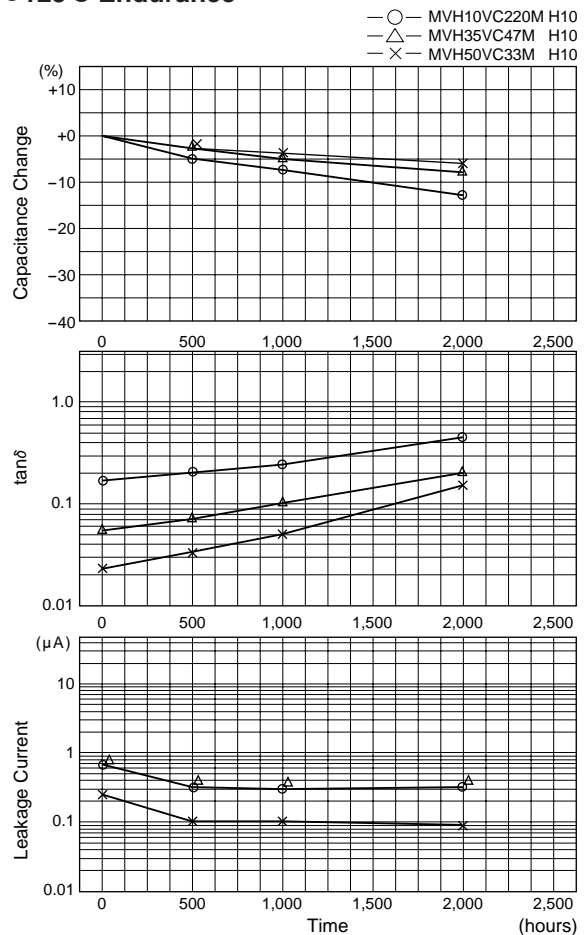

MVY Series

●Impedance/ESR vs Frequency

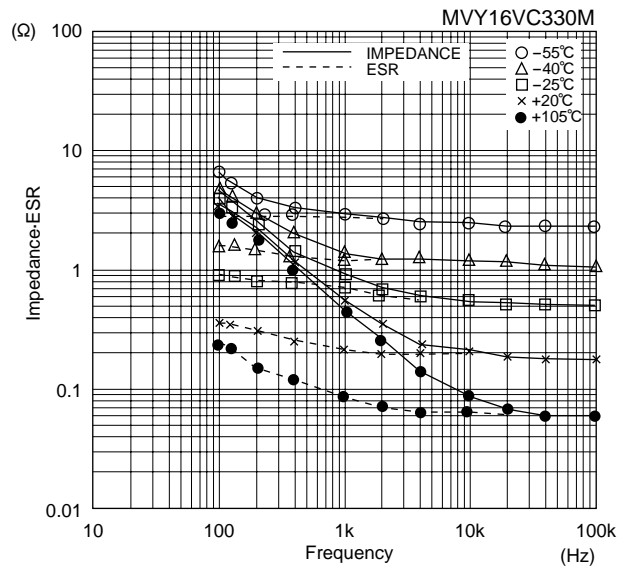
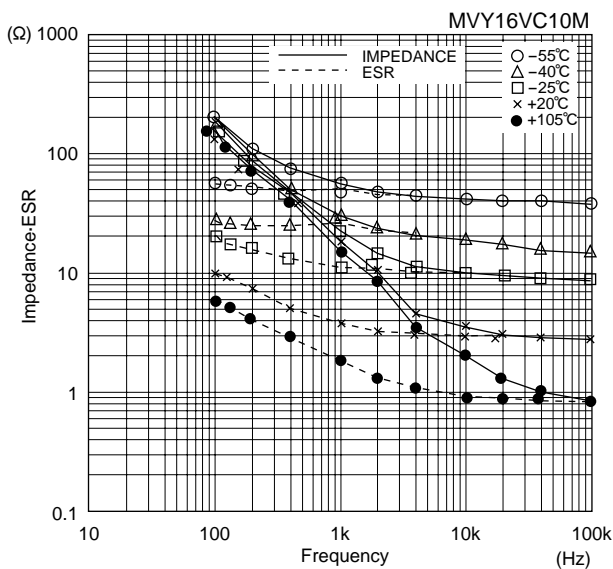

KMY Series

●105°C Endurance

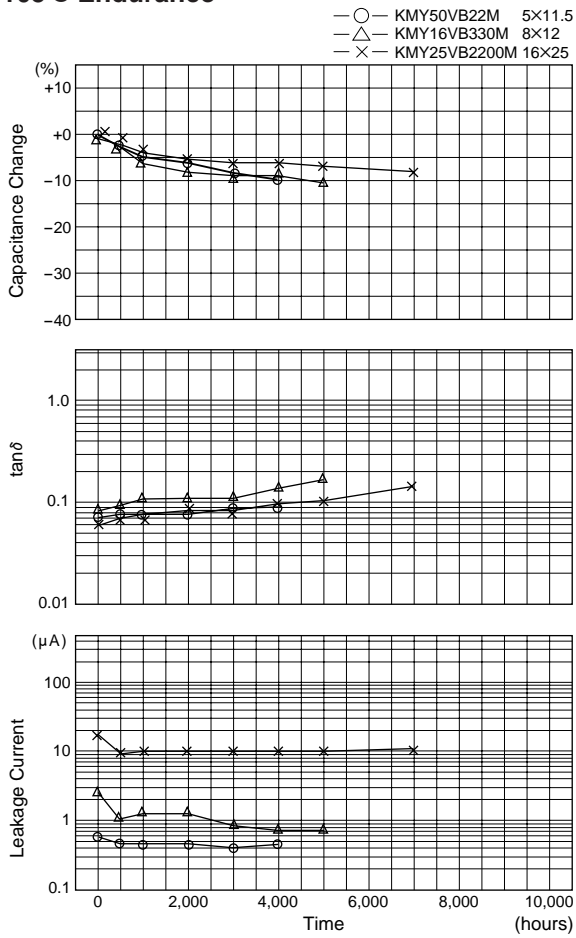

●105°C Shelf Life

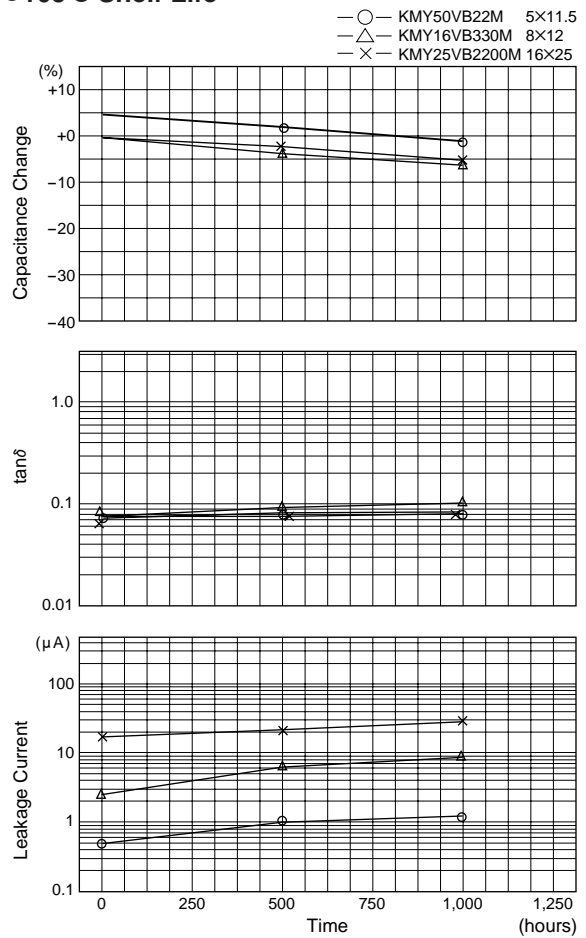

●Impedance/ESR

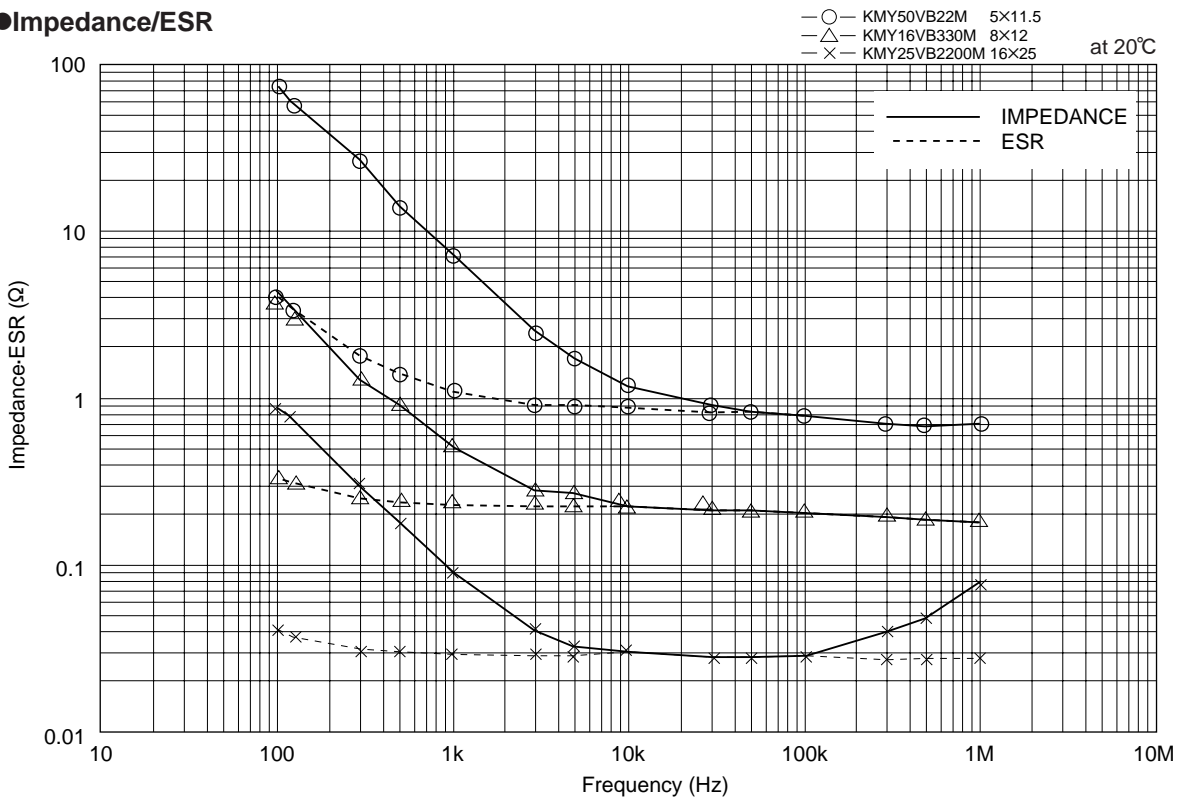

●105°C Endurance with Rated Ripple Current

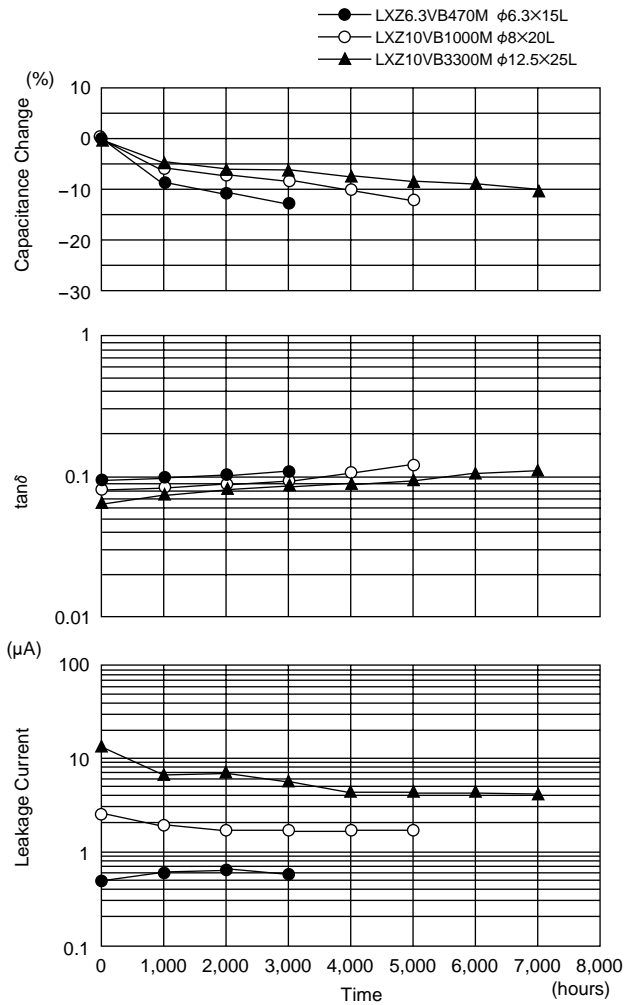

●105°C Endurance with Rated Ripple Current

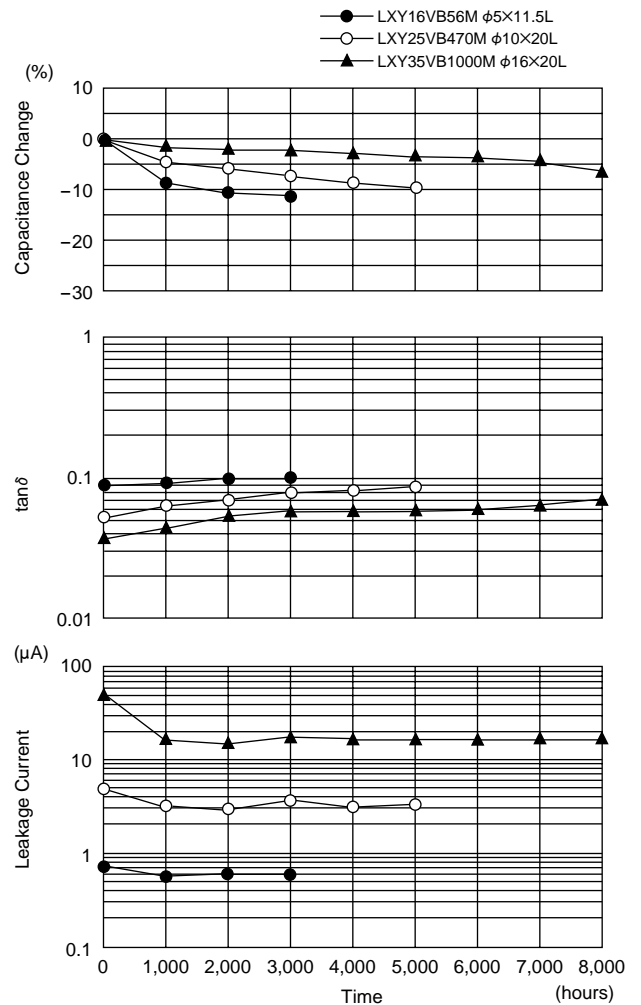

●Impedance-Frequency Characteristics

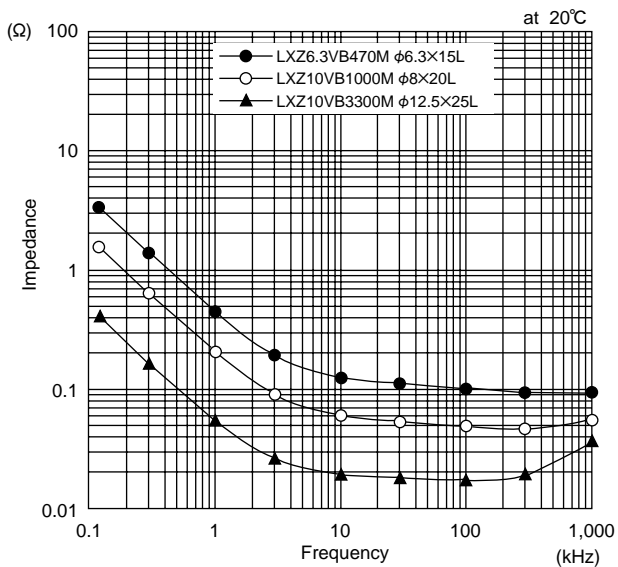

●Impedance-Frequency Characteristics

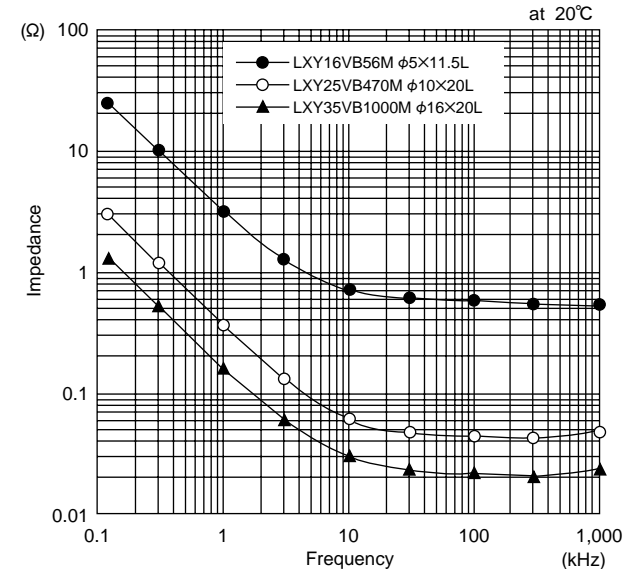

- LXV10VB82M $\phi 5 \times 11.5L$
- LXV25VB220M $\phi 8 \times 15L$
- ▲ LXV35VB560M $\phi 12.5 \times 20L$

●105°C Endurance with Rated Ripple Current

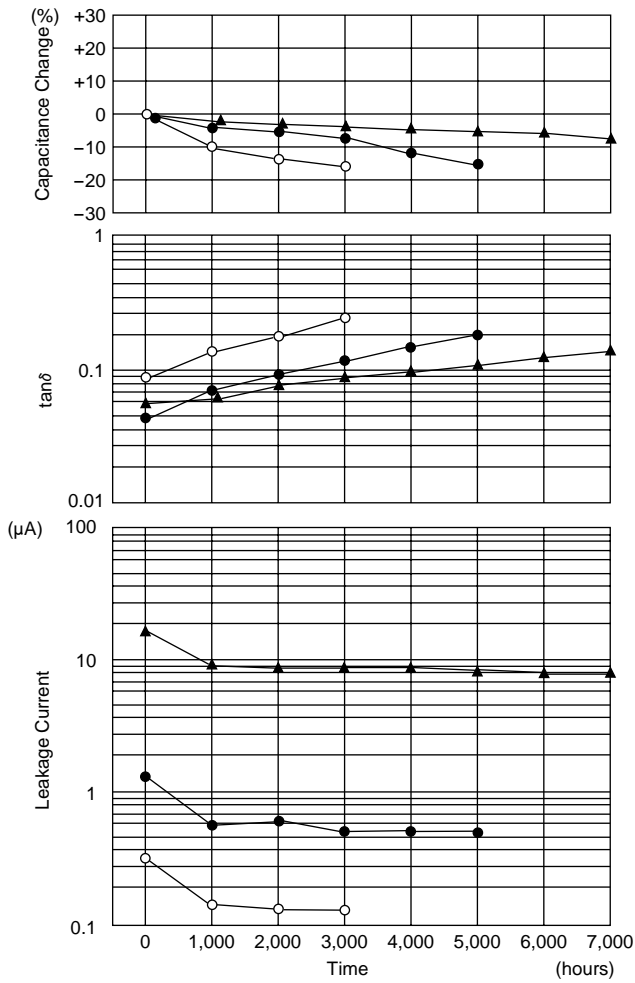

●105°C Shelf Life test

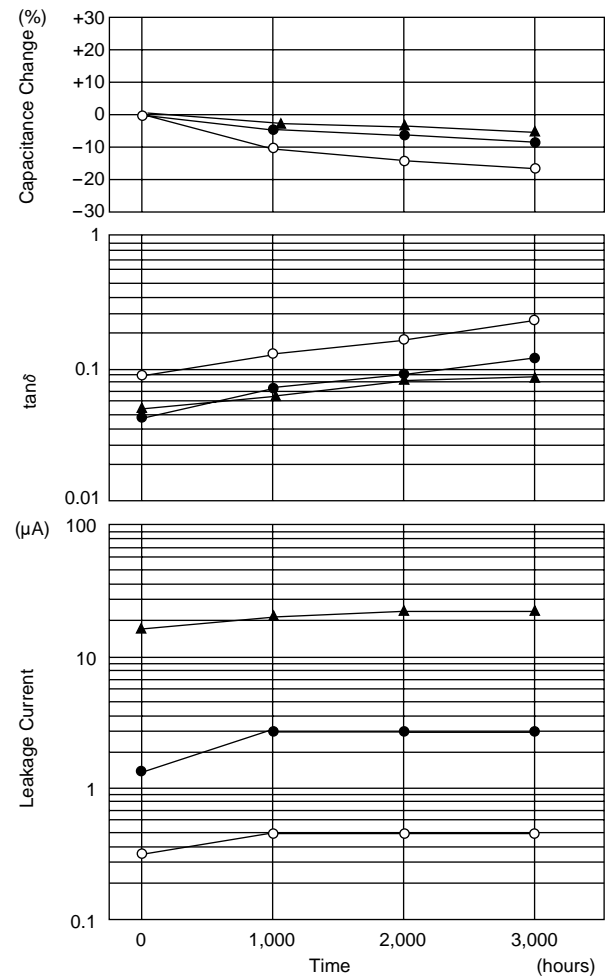

●Temperature Characteristics

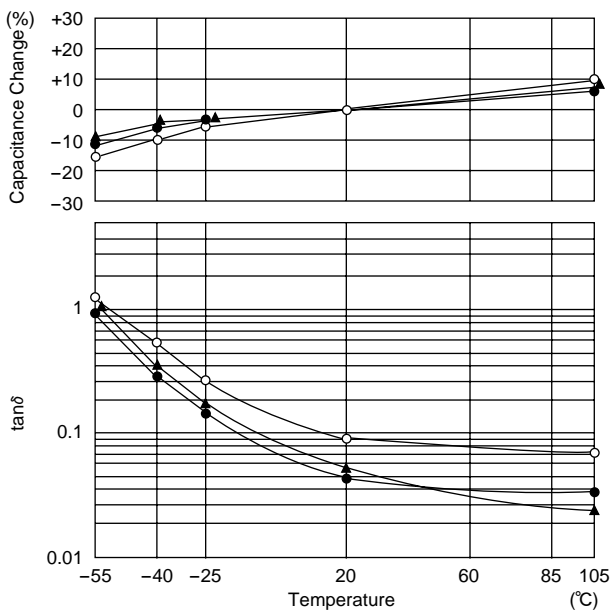

●Impedance-Frequency Characteristics

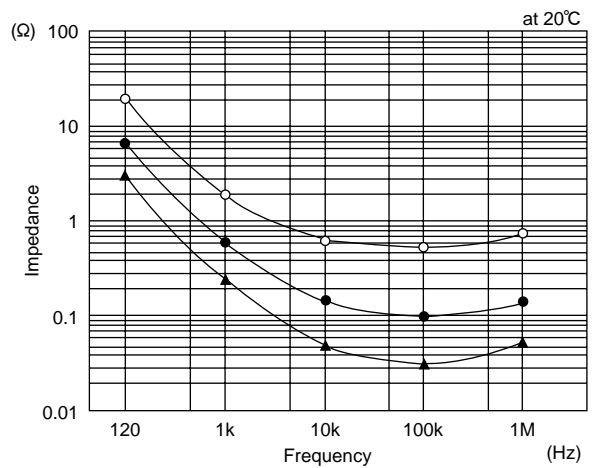

KMX Series

GXE Series

●105°C Endurance with Ripple Current

○ KMX160VB33M $\phi 10 \times 20L$
 △ KMX400VB10M $\phi 10 \times 20L$

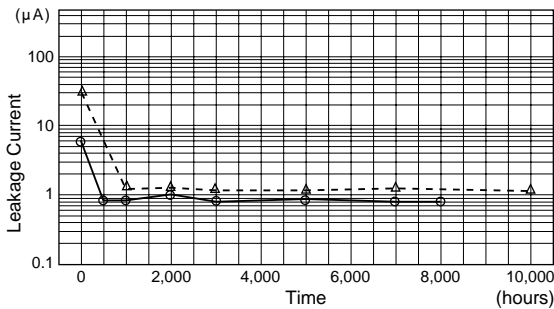
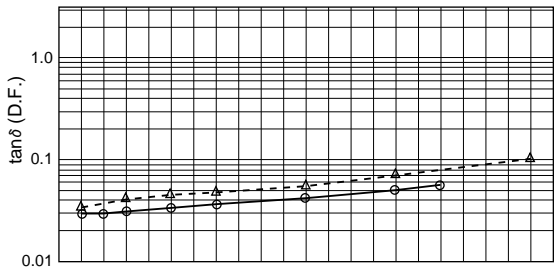
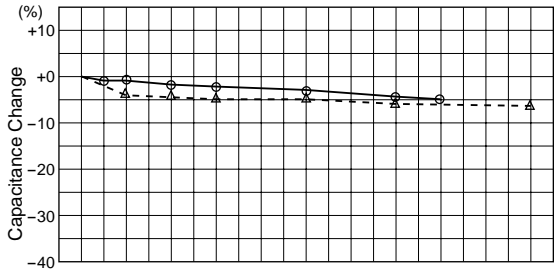

●125°C Endurance

○ GXE35VB100M $\phi 8 \times 12L$
 △ GXE50VB100M $\phi 10 \times 12.5L$
 □ GXE10VB3300M $\phi 16 \times 25L$

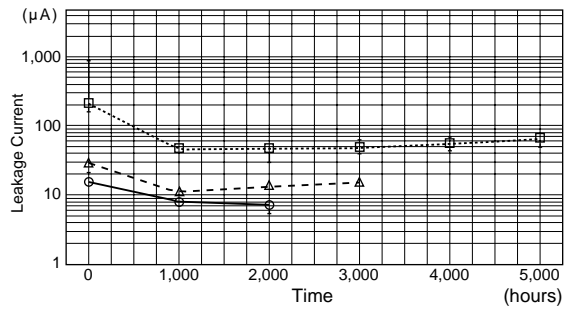
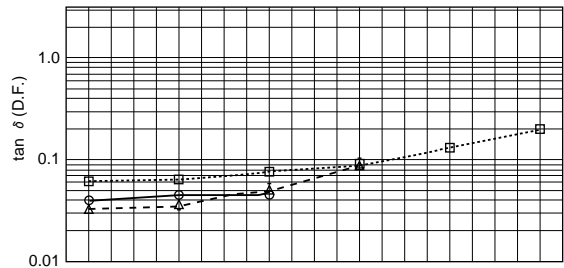
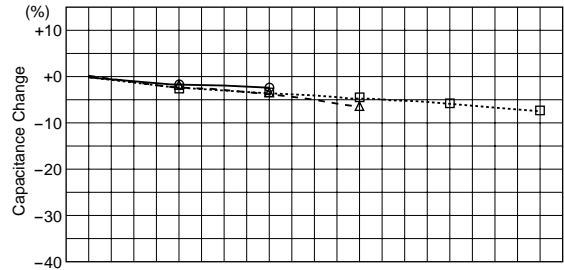

●Impedance-Frequency Characteristics at 20°C

○ KMX160VB33M $\phi 10 \times 20L$
 △ KMX400VB10M $\phi 10 \times 20L$

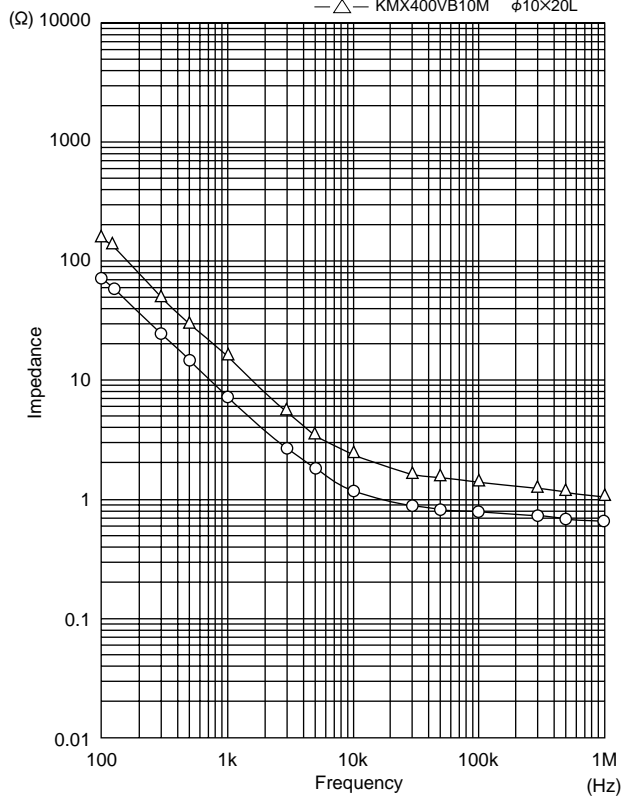

●Impedance-Frequency Characteristics at 20°C

○ GXE35VB100M $\phi 8 \times 12L$
 △ GXE50VB100M $\phi 10 \times 12.5L$
 □ GXE10VB3300M $\phi 16 \times 25L$

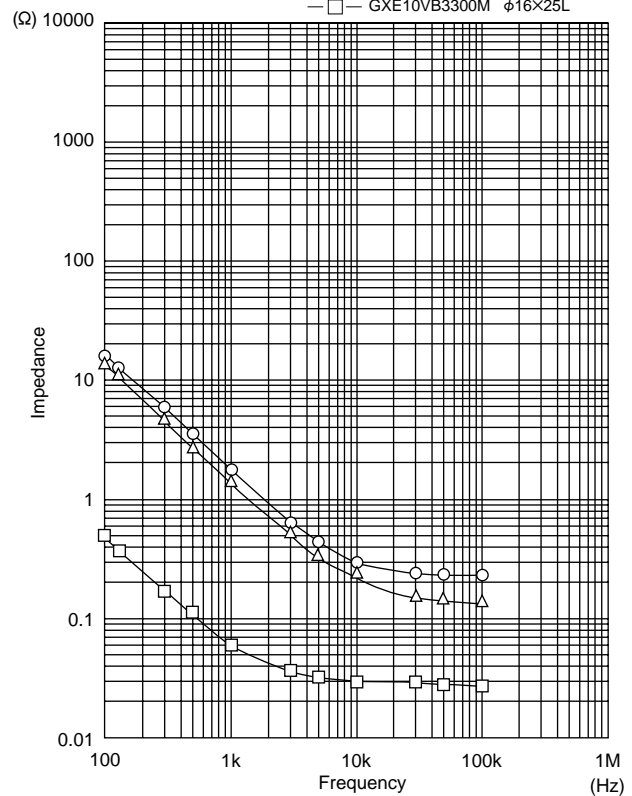

SMM Series

KMM Series

●85°C Endurance with Rated Ripple Current

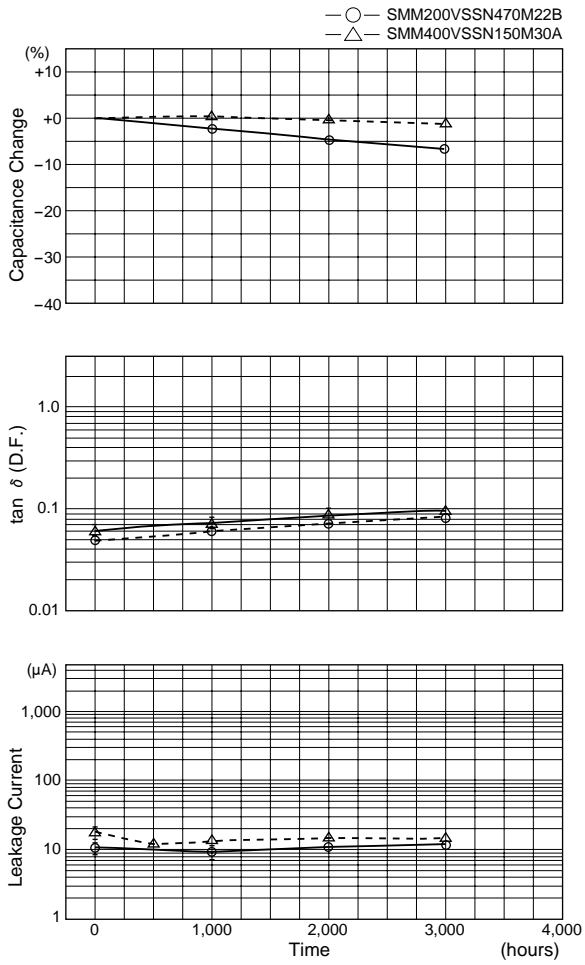

●105°C Endurance with Rated Ripple Current

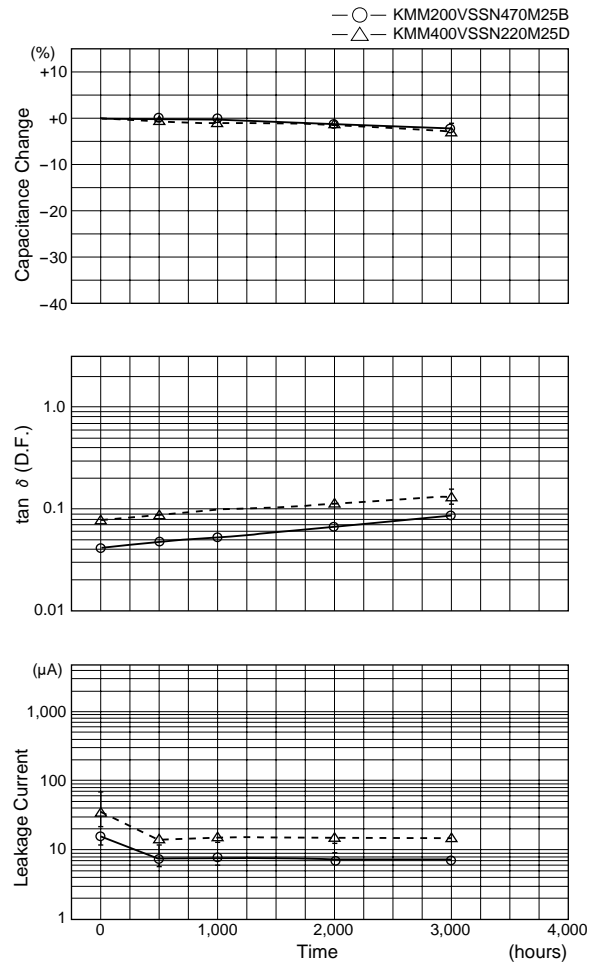

RWE/RWF/RWL Series

RWE/RWF series

●85°C Endurance with Rated Ripple Current

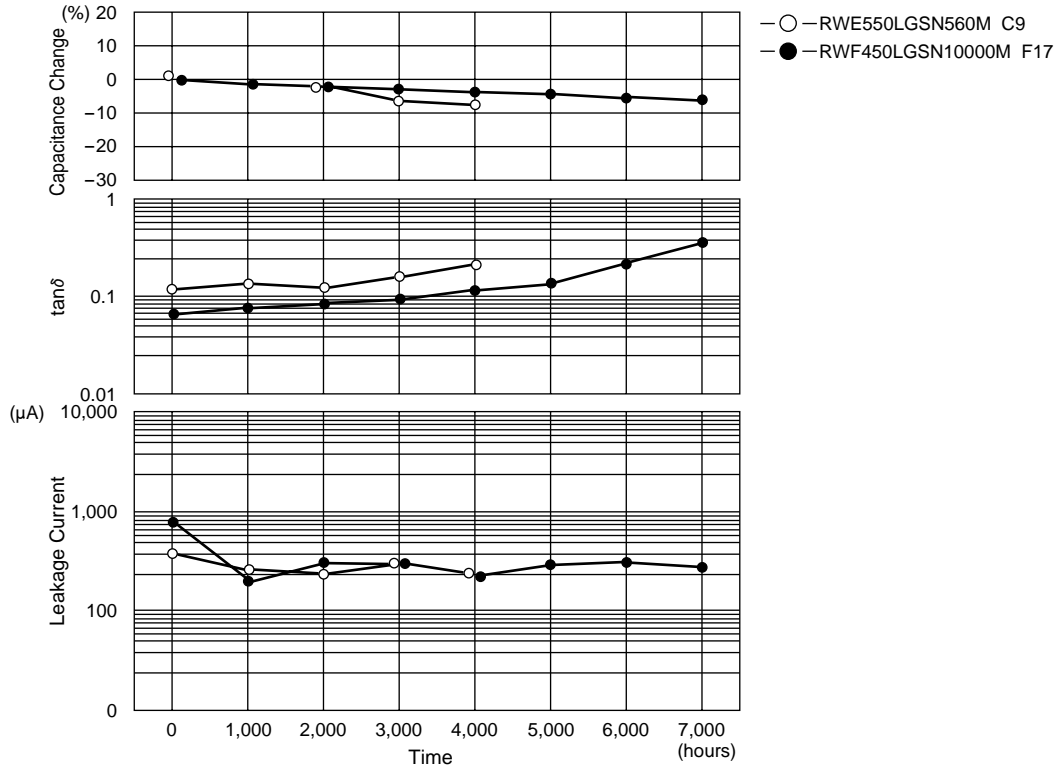

RWL series

●85°C Endurance with Rated Ripple Current

