



SOLID ELECTROLYTIC CAPACITORS WITH ORGANIC SEMICONDUCTOR (OS-CON™)

CAT. No. E1002E Version3.0

INDEX		
PRODUCT SEARCH	SERIES TABLE	➔
PRODUCTION GUIDE	PRECAUTIONS AND GUIDELINES	➔
	PACKAGING	➔
PRODUCT SPECIFICATIONS	FA Series	➔
	FH Series	➔
	FS Series	➔
	FP Series	➔
	FX Series	➔
	FRA Series	➔
RELIABILITY DATA		➔
TECHNICAL NOTE		➔

Item	Series	Rated Voltage Range (V _{dc})	Rated Capacitance Range (μF)	Category Temperature Range (°C)	Features
Lead Type	FA	4 to 25	15 to 330	-55 to +105	Standard, 105°C, 2,000hours
	FH	6.3 to 25	15 to 330	-55 to +105	Long Life, 105°C, 5,000hours
	FS	4 to 20	47 to 470	-55 to +105	Downsized, 105°C, 1,000hours
	FP	2.5 to 20	68 to 1,200	-55 to +105	Large capacitance, Low ESR, 105°C, 1,000hours
	FX	4 to 20	82 to 1,200	-55 to +105	Larger capacitance, Low ESR, 105°C, 1,000hours
	FRA <small>NEW!</small>	4	330 to 1,000	-55 to +105	Very Low ESR, 105°C, 2,000hours

For Environmentally friendly capacitors (Lead-free/non-PVC sleeving products), please consult us.

Information

Nippon Chemi-Con Corporation has decided that effective with the 2004 fiscal year we will introduce our "New Part Numbering System". We will publish the details and parameters of this new part numbering system in advance of its inception.

OS-CONs are solid electrolytic capacitors containing organic semiconductors as the electrolytes. Take note on the following subjects to use OS-CONs in excellent performance and high reliability.

CAUTIONS

1 Polarity

OS-CONs are polarized capacitors. Use OS-CONs after verifying their positive and negative polarities.

If an OS-CON™ is installed in the reverse polarity, its life may shorten because of increasing leakage current or short circuit.

2 Types of circuits in which OS-CONs are prohibited from being used

An OS-CON™ may be heated by soldering to increase in its leakage current slightly. This may have some influence on the characteristics OS-CONs in the following circuits :

(1) Time constant circuit (2) Coupling circuit (3) High impedance voltage holding circuit (4) Connection of two or more OS-CONs in series for higher withstand voltage.

3 Over - voltage

If an OS-CON™ is subject to application of voltage higher than the rated voltage for an instantaneous period, it may be defected due to short circuit. Note that the voltage over the rated voltage must not be applied to OS-CONs.

4 Repeat of rapid charging and discharging

If an OS-CON™ is used in a frequency rapid charging and discharging circuit or receive the flow of excess rush current, its life may be shorted by large leakage current or short circuit. The charging and discharging current through an OS-CON™ should be less than 10A or less than ten times of the rated ripple current.

5 Soldering

OS-CONs should be soldered under the soldering conditions defined in the delivery specification. Some improper soldering condition may cause the leakage current of OS-CONs to increase or other parameters to change.

6 Installation of OS-CONs on printed circuit board

Design a printed circuit board taking note on the standard on the lead position shifts of OS-CONs described in the brochures or delivery specification. If there are only insufficient spaces, OS-CONs may not be mounted on the printed circuit board or may be in contact with adjacent components.

7 Use of OS-CONs for industrial equipment

When OS-CONs are used for industrial equipment, the circuits should be designed to have sufficient margins in the ratings of OS-CON™ including capacitance and impedance. Without sufficient margins in the characteristics, the reliability of the OS-CONs may be reduced by their shorter life. Always contact us if you want to use OS-CONs for equipment affecting human lives such as space, aviation, atomic power, and medical devices. Never use OS-CONs for the uses without our prior approval.

NOTES
1 Notes on circuit designs for OS-CONs
(1) Rating and performance

Use OS-CONs within the rating and performance ranges defined in the brochures and delivery specification of OS-CONs after checking the operating and installation environments.

(2) Operating temperature and ripple current

- a) If an OS-CON™ is used at a temperature higher than the upper category temperature (105°C), its life may be remarkably shortened or the leakage current may increase to cause an OS-CON defective.
- b) Never make current larger than the rated ripple current through an OS-CON™. If excess ripple current flows through an OS-CON™, internal heat may be generated largely to make its life shortened or cause it to be defected due to short circuit.

(3) Leakage current

Depending on the soldering conditions, the leakage current of an OS-CON™ may increase slightly. The application of DC voltage enables the OS-CON™ to be repaired by itself. This leads the leakage current to be smaller gradually. The leakage current can be reduced fast if the DC voltage (which is less than the rating voltage) is applied at the temperature close to the upper category temperature.

(4) Applied voltage

- a) To secure the reliability of OS-CONs, it is recommended that the voltage applied to them should be less than 80% of the rated voltage. If OS-CONs of the 25V rating are used at a temperature higher than 85°C, apply the temperature reducing voltage described below to them. For OS-CONs of the 2.5V to 20V ratings, it is not necessary to apply the temperature reducing voltage.

85 °C → 25V

95 °C → 22.5V

105 °C → 20V

- b) The peak value of the ripple voltage superimposed with the DC voltage should be less than the rated voltage.
- c) OS – CONs are polarized capacitors. However, reverse voltage may be applied to them in transient phenomena such as at power - off of the unit including them. The reverse voltage should be less than 20% of the rating voltage for an extremely short period or less than 10% for a certain continuous period. It is recommended to reduce it further if the ambient temperature is considerably high.

(5) Failure mode

OS-CONs may end wear-out in association with temperature. They may be defected accidentally by over-voltage or over-current mainly causing short circuit. The failure rate of an OS-CON™ is dependent on the voltage applied to it and the ambient temperature.

(6) Insulation

- a) The outer sleeves of OS -CONs are not secured to be insulated. Do not use OS-CONs in areas requiring insulation.
- b) Isolate the case of an OS-CON™ from the positive and the negative terminals and adjacent circuit patterns.

(7) Design of printed circuit board

Take note on the following subjects when OS-CONs are installed verify on printed circuit boards.

- a) Verify that the lead spacing fit hole pitches on printed circuit board.
- b) Do not place heating components on boards to be close to OS-CONs or in the backside of them.
- c) If OS-CON™ are mounted on a double-sided PC board, design the board so that extra or through holes may not be opened below them.

(8) Parallel connection

If an OS-CON™ is connected with another type of a capacitor in parallel, larger ripple current may flow through one of OS-CONs. Take note on it in circuit designs.

(9) Miscellaneous

Check the following subjects in the designs of circuits containing OS -CONs:

- a) The electric characteristics of OS-CONs vary depending on the variations of the ambient temperature and frequency. Check the variations in designing circuits.
- b) If two or more OS-CONs are connected with each other in parallel, take the current balance among them into account.

2] Notes on installation of OS-CON™
(1) Notes on pre-installation of OS-CON™

- a) Do not reuse OS-CONs installed in a unit with the power supply turned on for another unit. No used OS-CONs shall be reused excluding those removed to measure their electric characteristics in periodical inspection.
- b) If an OS-CON™ stored for a long period may often increase in its leakage current, connect a resistor of approximately 1kΩ to the OS-CON™ for voltage treatment.

(2) Notes at installation of OS-CON™ (1)

- a) Install OS-CONs in a unit after confirming that their ratings (rated capacitance and rated voltages) meet the conditions of the unit.
- b) Install OS-CONs in the correct polarities.
- c) Take care not to drop OS-CONs on floors. Do not use OS-CONs dropped on floors.
- d) Do not deform OS-CONs to install them in units.

(3) Notes at installation of OS-CON™ (2)

- a) Install an OS-CON™ on a printed circuit board after confirming that its lead pitch is equivalent to the corresponding hole pitch.
- b) At the picking, mounting, and locating by an automatic inserter or the cutting of the leads of an OS-CON™ by an automatic moulder, some stress may be applied to the OS-CON™. Take note on the shock.
- c) Do not apply any excess force with the terminals of OS-CON™.

(4) Heating

In preheating or heating for adhesion and fixing of other electronic components, the temperature put to OS-CONs should be less than 120°C. The total heating period should be shorter than 90 seconds.

(5) Soldering by soldering iron

- a) OS-CONs should be soldered under the conditions (on soldering temperature and duration), as follows. The iron tip at the temperature of 350°C or less may be put to each lead of an OS-CON™ for shorter than three seconds.
- b) The lead wire terminals of a OS-CON™ may be required to be processed because the distance between the terminals is not equivalent to that of corresponding holes on the printed circuit board. Process the terminals so that no stress may be applied to the OS-CON™ itself before soldering.
- c) Do not make the tip of a soldering iron be in contact with OS-CONs themselves.
- d) The leakage current of a soldered OS-CON™ may increase slightly depending on several conditions (including pre heating, soldering temperature and period, and board material and thickness). However, the leakage current decreases gradually by the self-repair characteristic of OS-CON™ when it is used with voltage application.

(6) Flow soldering

- a) Do not dip OS-CONs themselves into melted solder in soldering. Only provide soldering for the board surface in the backside of the surface on which the OS-CONs are mounted.
- b) Solder OS-CONs under the soldering conditions (soldering temperature and dip period) as follows.
Pre-heat condition : atmosphere temperature 120°C or less for up to 90 seconds.
Soldering condition : solder temperature 245°C or less for up to 3 seconds.
- c) Note that flux may not adhere to any substances except lead wires.
- d) Do not make any other components fallen at OS-CONs in soldering.
- e) The leakage current of a soldered OS-CON™ may increase slightly depending on several conditions (including pre-heating, soldering temperature and period, and board material and thickness). However, the leakage current decreases gradually by the self-repair characteristic of OS-CON™ when it is used with voltage application.

(7) Handling of OS-CON™ after soldering

- a) Do not incline, bend, and twist OS-CONs.
- b) Do not grab an OS-CON™ as a handle to carry the printed circuit board.
- c) Do not hit objects against OS-CONs. When printed circuit boards are piled up, do not make them and / or other components be in contact with OS-CONs.
- d) Do not drop printed circuit boards with OS-CONs installed.

(8) Cleaning of printed circuit board.

Contact us regarding washing OS-CON™ mounted printed circuit board.

(9) Fixing and coating materials.

Contact us for the fixing and coating materials appropriate for OS-CONs and their heat curing conditions.

3 Notes on use of OS-CONs in unit

- (1) Never make your fingers contact with the terminals of OS-CONs.
- (2) Do not make terminals of an OS-CONs be in contact with each other through an conductor. Do not put conductive liquid such as acid and alkali solutions on OS-CONs.
- (3) Confirm that the unit including OS-CONs is placed in a proper conditions. Do not place the unit in the following areas:
 - a) Area in which they are directly exposed to water, brine, or oil or in condensation status.
 - b) Area filled with poisonous gases (including hydrogen sulfide, sulfurous acid, nitrous acid, chlorine, and ammonia)
 - c) Area to which ultraviolet and / or radial rays are radiated
 - d) Area with vibration and / or shock exceeding the rating values defined in the delivery specification.
- (4) Provide aging for a unit containing OS-CONs within the period defined for them.
- (5) It is recommended to use a unit containing OS-CONs in the normal temperature range (15°C to 35°C) and the normal humidity range (75% or less).

4 Action at emergency

- (1) At the occurrence of short circuit in an OS-CON™, some heat is generated from it if the short current is rather small (3A or less for an OS-CON™ with diameter of $\phi 8 \sim \phi 10$ or 1A or less for that with diameter of $\phi 6.3$ or less). If the short current exceeds the above value, the OS-CON™ is heated excessively. Then the impregnated organic semiconductor may be resolved and liquefied to make the internal pressure higher. The liquefied organic semiconductor and smelling gas may leak through the gap between the sealing material and the aluminum case or lead wire. If so, turn off the power of the unit without your face and hands being close to the OS-CON™.
- (2) Depending on the operating conditions of OS-CONs, it takes several seconds to several minutes for liquefied organic semiconductor and smelling gas to be generated if short circuit occurs. Design the protection circuit so that it can start its operation within the period.
- (3) If the generated gas is in your eyes, clean the eyes with water immediately. If you inhale in the gas, rinse your mouth immediately.
- (4) Never lick the electrolyte (organic semiconductor) in OS-CONs. If the electrolyte is put on your skin, wash it away carefully with soap.
- (5) The materials used for OS-CONs (including organic semiconductors, capacitor sheets, resins, and sleeves) are flammable. If short current is extremely large enough to cause sparks to occur at the short section or an adjacent component is burned, the resin and / or sleeve of the OS-CON™ may burn. Take sufficient note on the installation procedures and locations of OS-CONs and the pattern designs of printed circuit boards.

5 Storage

- (1) Store OS-CONs in an area in the temperature range between 15°C to 35°C and the relative humidity of 75% or less without direct sunshine. In addition, store them in the packaged states if possible.
- (2) OS-CONs should be stored for up to one year to maintain their good soldering features and characteristics.
- (3) OS-CONs are recommended that you shall open the bag just before use and capacitors shall be used up. If some quantity was not need, please seal it with adhesive tape.
- (4) Never store OS-CONs in any area in which they are directly exposed to water, brine, or oil or in condensation status.
- (5) Never store OS-CONs in any area filled with poisonous gases (including hydrogen sulfide, sulfurous acid, nitrous acid, chlorine, and ammonia).
- (6) Never store OS-CONs in any area to which ultraviolet and / or radial rays are radiated.

6 Exhaustion of OS-CON™

OS-CONs are composed of organic compounds, resins, and metals. Request an industrial dispose company to dispose of used OS-CONs.

7 Brochure

The information in the brochures on OS-CONs may be changed without notice. Any data described in the brochures are the typical values. They cannot secure the performance of OS-CONs.

◆TAPING SPECIFICATIONS

●CONFIGURATIONS

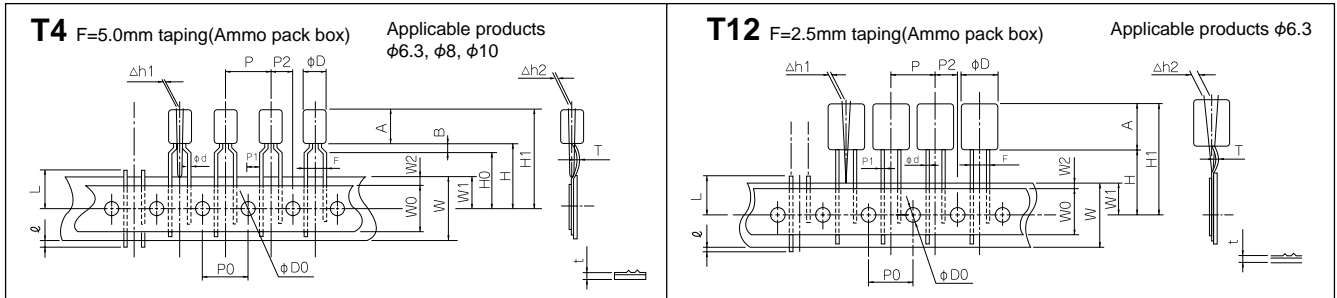

●DIMENSIONS

Unit : mm

CODE	CASE SIZE		φd	P	P0	P1	P2	F	W	W0	W1	W2	H	H0	H1	φ	D0	Δh1	Δh2	t	L	T	B					
	φD	A																										
	+0.5 max.	+1.0 max.	±0.05	±1.0	±0.2	±0.5	±1.0	+0.5 -0.2	±0.5	min.	±0.5	max.	±0.75	±0.5	max.	max.	±0.2	±1.0	±2.0	±0.2	max.	±1.0	max.					
T4	6.3	9.8	0.50	12.7	12.7	3.85	6.35	5.0	18.0	10.0	9.0	2.5	18.5	16.0	30.05	0	4.0	0	0	0.5	11.0	0	2.5					
	8	10.5	0.60										20.0		32.25								4.0	4.0	4.0	4.0	4.0	4.0
	10	5	0.50										-		25.25								-	-	-	-	-	-
	10	10.5	0.60										-		30.75								-	-	-	-	-	-
	10	16	0.60										-		36.25								-	-	-	-	-	-
T12	6.3	9.8	0.50			5.1		2.5					-	30.05									-					

*Other taping specifications shall be subject to inquiry. φd of FX and FP series is 0.6mm.

◆CUT/FORMED LEAD SPECIFICATION

Unit : mm

	Applicable Products(φD)	Code	Lead configuration										
5mm pitch Forming	φ 6.3 φ 8	F F1	<table border="1"> <tr> <th>Code</th> <th>F</th> <th>F1</th> </tr> <tr> <th>φ</th> <td>5.0</td> <td>4.0</td> </tr> </table>	Code	F	F1	φ	5.0	4.0				
Code	F	F1											
φ	5.0	4.0											
Lead Cut	φ 6.3 φ 8 φ10	E E4 E5 E7	<table border="1"> <tr> <th>Code</th> <th>E</th> <th>E4</th> <th>E5</th> <th>E7</th> </tr> <tr> <th>φ</th> <td>5.0</td> <td>4.0</td> <td>3.5</td> <td>2.5</td> </tr> </table> <p>*)E7:Applicable products φ6.3, 8</p>	Code	E	E4	E5	E7	φ	5.0	4.0	3.5	2.5
Code	E	E4	E5	E7									
φ	5.0	4.0	3.5	2.5									

◆MINIMUM PACKING QUANTITY

CASE SIZE (mm)		QUANTITY		
		Bag	Taping(pcs/box)	
φD	L	(pcs/bag)	T4	T12
6.3	9.8	200	2000	2000
8	10.5	100	1000	-
10	5	100	500	-
10	10.5	100	500	-
10	16	100	500	-

FA Series (Standard)

- 105°C, 2000 hours
- Low impedance at high frequency and high ripple current capability
- Suitable for switching power supplies and noise filter



◆ SPECIFICATIONS

Items	Performance Requirements		
Category	-55 to +105°C		
Temperature Range	-55 to +105°C		
Rated Voltage Range	4 to 25Vdc		
Rated Capacitance Range	15 to 330µF (at 20°C, 120Hz)		
Tolerance on Rated Capacitance	±20% (M), ±10% (K) (at 20°C, 120Hz)		
Leakage Current	See STANDARD RATINGS table (at 20°C, 2 min)		
Dissipation Factor (tanδ)	See STANDARD RATINGS table (at 20°C, 120Hz)		
Characteristics at High and Low Temperature	Z (-55°C) / Z (20°C)	0.75 to 1.25 (at 100Hz)	
	Z (105°C) / Z (20°C)		
Endurance	After 2000hours with applying rated voltage at 105°C, shall not exceed or within the following values at 20°C. (20V shall be applied for item of rated voltage 25V.)		
	Capacitance change	Within ±20% of the initial value	
	tanδ	1.5 times of the initial specified value	
	Leakage current	The initial specified value	
Damp Heat, Steady State	After 1000hours with no load at 60°C, 90 to 95%RH, shall not exceed or within the following values at 20°C. (after voltage treatment)		
	Capacitance change	Within ±10% of the initial value	
	tanδ	Except 10×5	1.5 times of the initial specified value
		10×5	2.0 times the initial specified value
	Leakage current	The initial specified value	

◆ DIMENSIONS

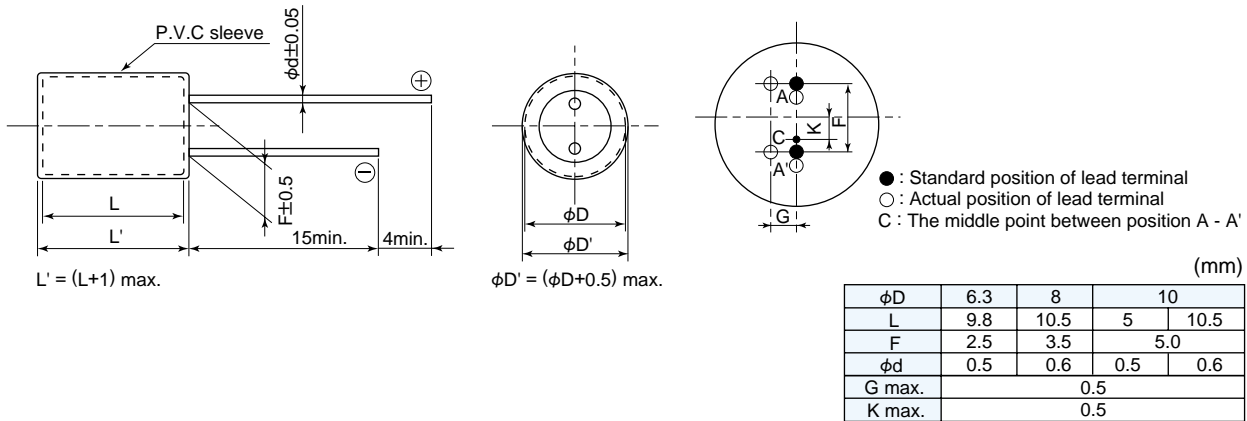

◆ PART NUMBERING SYSTEM

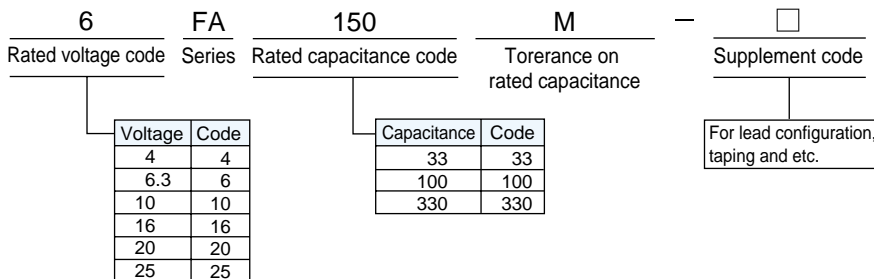

◆STANDARD RATINGS

Part No.	Rated voltage	Rated capacitance	Max ESR	Rated ripple current	Max tan δ	Max leakage current	Case size
	(V _{dc})	(μ F) 1)	(m Ω) 2)	(mA rms) 3)		(μ A) 4)	ϕ DXL (mm)
4FA220MA	4	220	55	2,400	0.07	17.6	10×5
6FA150M	6.3	150	30	2,780	0.07	18.9	8×10.5
6FA150MA	6.3	150	60	2,100	0.07	18.9	10×5
6FA330M	6.3	330	25	3,500	0.07	41.5	10×10.5
10FA47M	10	47	60	2,020	0.06	4.7	6.3×9.8
10FA68M	10	68	50	2,040	0.07	13.6	6.3×9.8
10FA100M	10	100	30	2,680	0.07	20.0	8×10.5
10FA100MA	10	100	60	2,100	0.07	20.0	10×5
10FA220M	10	220	27	3,370	0.07	44.0	10×10.5
16FA47M	16	47	60	1,830	0.06	15.0	6.3×9.8
16FA68M	16	68	40	2,600	0.06	21.7	8×10.5
16FA68MA	16	68	65	1,850	0.07	21.7	10×5
16FA100M	16	100	30	2,740	0.06	32.0	8×10.5
16FA150M	16	150	28	3,260	0.06	48.0	10×10.5
20FA33M	20	33	70	1,710	0.06	13.2	6.3×9.8
20FA47M	20	47	40	2,450	0.06	18.8	8×10.5
20FA68M	20	68	36	2,600	0.06	27.2	8×10.5
20FA100M	20	100	30	3,210	0.06	40.0	10×10.5
25FA15M	25	15	70	1,650	0.04	3.7	6.3×9.8
25FA22M	25	22	40	2,330	0.06	5.5	8×10.5
25FA22MA	25	22	70	1,600	0.07	11.0	10×5
25FA33M	25	33	35	2,900	0.06	8.2	10×10.5
25FA47M	25	47	35	2,980	0.06	11.7	10×10.5

 Note 1) Tolerance on rated capacitance $\pm 20\%$ (M), $\pm 10\%$ (K)

2) ESR : 100kHz to 300kHz

3) Rated ripple current : 100kHz, 45°C

4) Max. leakage current : After 2 minutes.

◆CASE SIZE

μ F \ V _{dc}	4	6.3	10	16	20	25
15						6.3×9.8
22						8×10.5 10×5
33					6.3×9.8	10×10.5
47			6.3×9.8	6.3×9.8	8×10.5	10×10.5
68			6.3×9.8	8×10.5 10×5	8×10.5	
100			8×10.5 10×5	8×10.5	10×10.5	
150		8×10.5 10×5		10×10.5		
220	10×5		10×10.5			
330		10×10.5				

◆TEMPERATURE MULTIPLYING FACTOR OF RATED RIPPLE CURRENT

Ambient temperature (°C)	to +45	to +65	to +85	to +95	to +105
Multiplying factor	1	0.85	0.7	0.4	0.25

FH Series

- 105°C, 5000 hours
- Long life and high reliability
- Suitable for a industrial usage

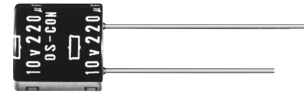

◆ SPECIFICATIONS

Items	Performance Requirements	
Category		
Temperature Range	-55 to +105°C	
Rated Voltage Range	6.3 to 25Vdc	
Rated Capacitance Range	15 to 330µF (at 20°C, 120Hz)	
Tolerance on Rated Capacitance	±20% (M) (at 20°C, 120Hz)	
Leakage Current	I = 0.02CV or 0.5µA Whichever is greater I : Leakage current (µA), C : Rated capacitance (µF), V : rated voltage (Vdc) (at 20°C, 2 min)	
Dissipation Factor (tanδ)	See STANDARD RATINGS table (at 20°C, 120Hz)	
Characteristics at High and Low Temperature	Z (-55°C) / Z (20°C)	0.75 to 1.25 (at 100Hz)
	Z (105°C) / Z (20°C)	
Endurance	After 5000hours with applying rated voltage at 105°C, shall not exceed or within following values at 20°C. (20V shall be applied for item of rated voltage 25V.)	
	Capacitance change	Within ±30% of the initial value
	tanδ	1.5 times of the initial specified value
	Leakage current	5.0 times of the initial specified value
Damp Heat, Steady State	After 1000hours with no load at 60°C, 90 to 95%RH, shall not exceed or within following values at 20°C. (after voltage treatment)	
	Capacitance change	Within ±10% of the initial value
	tanδ	1.5 times of the initial specified value
	Leakage current	The initial specified value

◆ DIMENSIONS

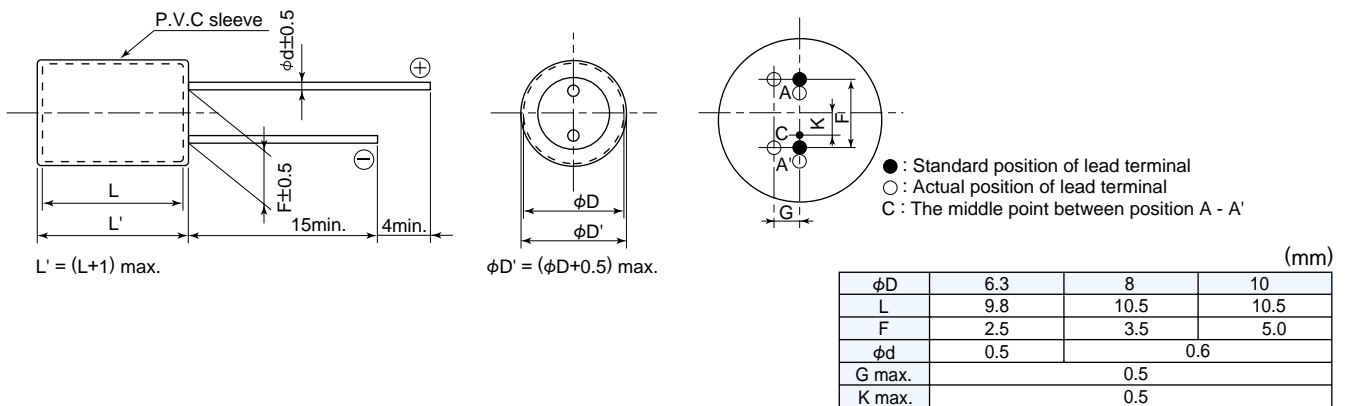

◆ PART NUMBERING SYSTEM

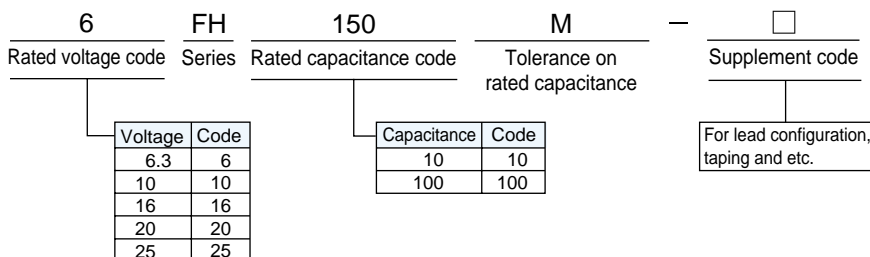



SOLID ELECTROLYTIC CAPACITORS WITH ORGANIC SEMICONDUCTOR

FH Series

◆STANDARD RATINGS

Part No.	Rated voltage	Rated capacitance	Max ESR	Rated ripple current	Max tanδ	Max leakage current	Case size
	(Vdc)	(μF) 1)	(mΩ) 2)	(mA rms) 3)		(μA) 4)	φD×L (mm)
6FH150M	6.3	150	30	2,780	0.07	18.9	8×10.5
6FH330M	6.3	330	25	3,500	0.07	41.6	10×10.5
10FH68M	10	68	50	2,000	0.07	13.6	6.3×9.8
10FH220M	10	220	27	3,370	0.07	44.0	10×10.5
16FH47M	16	47	60	1,830	0.06	15.0	6.3×9.8
16FH100M	16	100	30	2,740	0.06	32.0	8×10.5
16FH150M	16	150	28	3,260	0.06	48.0	10×10.5
20FH33M	20	33	70	1,710	0.06	13.2	6.3×9.8
20FH47M	20	47	40	2,450	0.06	18.8	8×10.5
20FH68M	20	68	36	2,600	0.06	27.2	8×10.5
20FH100M	20	100	30	3,210	0.06	40.0	10×10.5
25FH15M	25	15	70	1,650	0.04	7.5	6.3×9.8

Note 1) Tolerance on rated capacitance ±20%(M)

2) ESR : 100kHz to 300kHz

3) Rated ripple current : 100kHz, 45°C

4) Max. leakage current : After 2 minutes.

◆CASE SIZE

μF \ Vdc	6.3	10	16	20	25
15					6.3×9.8
33				6.3×9.8	
47			6.3×9.8	8×10.5	
68		6.3×9.8		8×10.5	
100			8×10.5	10×10.5	
150	8×10.5		10×10.5		
220		10×10.5			
330	10×10.5				

◆TEMPERATURE MULTIPLYING FACTOR OF RATED RIPPLE CURRENT

Ambient temperature (°C)	to +45	to +65	to +85	to +95	to +105
Multiplying factor	1	0.85	0.7	0.4	0.25



SOLID ELECTROLYTIC CAPACITORS WITH ORGANIC SEMICONDUCTOR

FS Series

- 105°C, 1000 hours
- Miniaturized series of FA series



◆ SPECIFICATIONS

Items	Performance Requirements	
Category		
Temperature Range	-55 to +105°C	
Rated Voltage Range	4 to 20Vdc	
Rated Capacitance Range	47 to 470µF (at 20°C, 120Hz)	
Tolerance on Rated Capacitance	±20% (M) (at 20°C, 120Hz)	
Leakage Current	I = 0.05CV (max.) I : Leakage current (µA), C : Rated capacitance (µF), V : rated voltage (Vdc) (at 20°C, 2 min)	
Dissipation Factor (tanδ)	See STANDARD RATINGS table (at 20°C, 120Hz)	
Characteristics at High and Low Temperature	Z (-55°C) / Z (20°C)	0.75 to 1.25 (at 100Hz)
	Z (105°C) / Z (20°C)	
Endurance	After 1000hours with applying rated voltage at 105°C, shall not exceed or within following values at 20°C.	
	Capacitance change	Within ±20% of the initial value
	tanδ	1.5 times of the initial specified value
	Leakage current	The initial specified value
Damp Heat, Steady State	After 1000hours with no load at 60°C, 90 to 95%RH, shall not exceed or within following values at 20°C. (after voltage treatment)	
	Capacitance change	Within ±20% of the initial value
	tanδ	2.0 times of the initial specified value
	Leakage current	The initial specified value

◆ DIMENSIONS

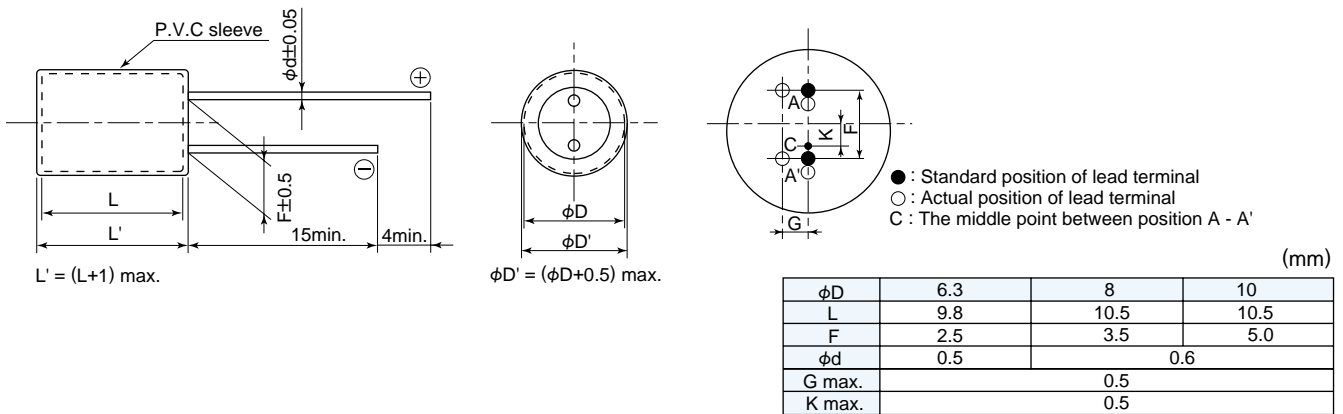

◆ PART NUMBERING SYSTEM

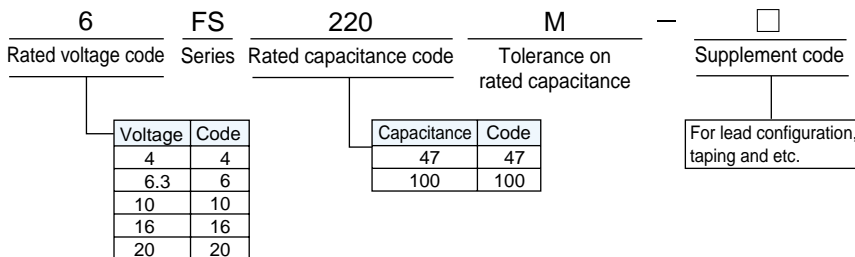



SOLID ELECTROLYTIC CAPACITORS WITH ORGANIC SEMICONDUCTOR

FS Series

◆STANDARD RATINGS

Part No.	Rated voltage	Rated capacitance	Max ESR	Rated ripple current	Max tan δ	Max leakage current	Case size
	(V _{dc})	(μ F) 1)	(m Ω) 2)	(mA rms) 3)		(μ A) 4)	ϕ D×L (mm)
4FS150M	4	150	40	2,100	0.08	30.0	6.3×9.8
4FS470M	4	470	25	3,500	0.07	94.0	10×10.5
6FS220M	6.3	220	30	3,000	0.07	69.3	8×10.5
10FS100M	10	100	40	2,100	0.07	50.0	6.3×9.8
10FS150M	10	150	30	2,780	0.07	75.0	8×10.5
10FS330M	10	330	25	3,500	0.07	165.0	10×10.5
16FS68M	16	68	50	2,000	0.07	54.4	6.3×9.8
20FS47M	20	47	60	1,830	0.06	47.0	6.3×9.8
20FS100M	20	100	30	2,740	0.07	100.0	8×10.5
20FS150M	20	150	30	3,200	0.07	150.0	10×10.5

Note 1) Tolerance on rated capacitance $\pm 20\%$ (M)

2) ESR : 100kHz to 300kHz

3) Rated ripple current : 100kHz, 45°C

4) Max. leakage current : After 2 minutes.

◆CASE SIZE

μ F \ V _{dc}	4	6.3	10	16	20
47					6.3×9.8
68				6.3×9.8	
100			6.3×9.8		8×10.5
150	6.3×9.8		8×10.5		10×10.5
220		8×10.5			
330			10×10.5		
470	10×10.5				

◆TEMPERATURE MULTIPLYING FACTOR OF RATED RIPPLE CURRENT

Ambient temperature (°C)	to +45	to +65	to +85	to +95	to +105
Multiplying factor	1	0.85	0.7	0.4	0.25

FP Series

- 105°C, 1000 hours
- Higher capacitance and lower ESR
- Suitable for the backup capacitor of the power supply circuit of CPU

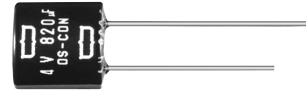

◆ SPECIFICATIONS

Items	Performance Requirements	
Category	-55 to +105°C	
Temperature Range	-55 to +105°C	
Rated Voltage Range	2.5 to 20Vdc	
Rated Capacitance Range	68 to 1,200µF (at 20°C, 120Hz)	
Tolerance on Rated Capacitance	±20% (M) (at 20°C, 120Hz)	
Leakage Current	I = 0.1CV (max.) I : Leakage current (µA), C : Rated capacitance (µF), V : rated voltage (Vdc) (at 20°C, 2 min)	
Dissipation Factor (tanδ)	See STANDARD RATINGS table (at 20°C, 120Hz)	
Characteristics at High and Low Temperature	Z (-55°C) / Z (20°C)	0.75 to 1.25 (at 100Hz)
	Z (105°C) / Z (20°C)	
Endurance	After 1000hours with applying rated voltage at 105°C, shall not exceed or within following values at 20°C.	
	Capacitance change	Within ±20% of the initial value
	tanδ	1.5 times of the initial specified value
	Leakage current	The initial specified value
Damp Heat, Steady State	After 1000hours with no load at 60°C, 90 to 95%RH, shall not exceed or within following values at 20°C. (after voltage treatment)	
	Capacitance change	Within ±20% of the initial value
	tanδ	2.0 times of the initial specified value
	Leakage current	The initial specified value

◆ DIMENSIONS

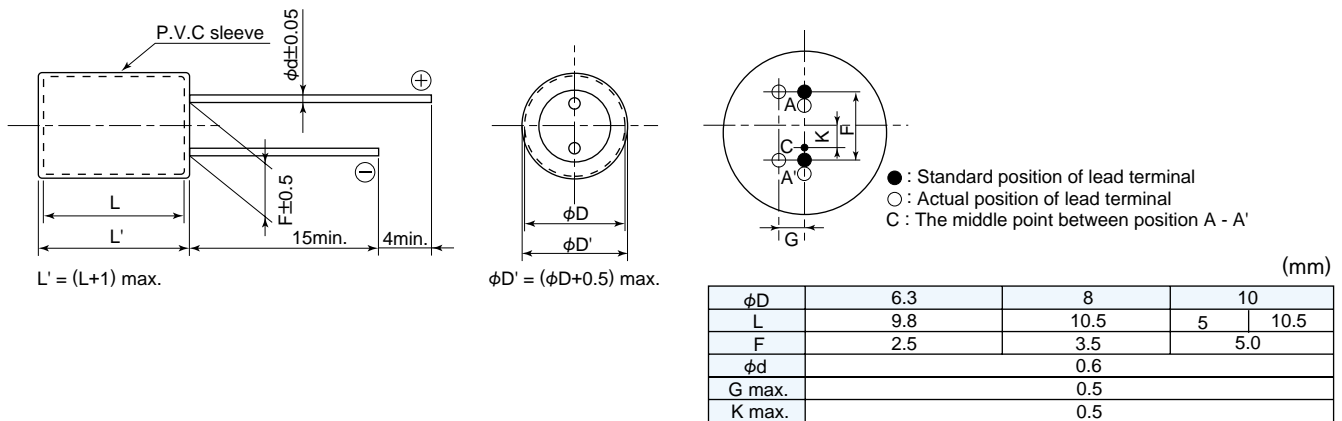

◆ PART NUMBERING SYSTEM

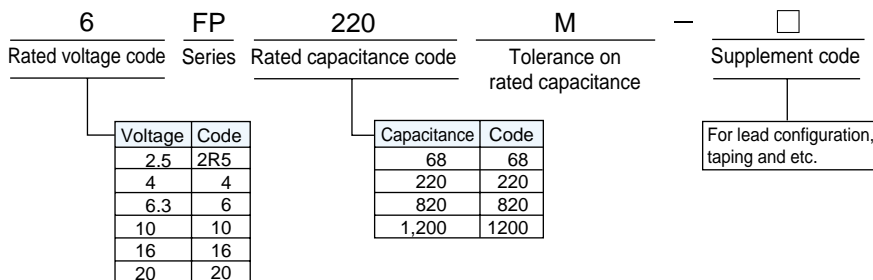



SOLID ELECTROLYTIC CAPACITORS WITH ORGANIC SEMICONDUCTOR

FP Series

◆STANDARD RATINGS

Part No.	Rated voltage	Rated capacitance	Max ESR	Rated ripple current	Max tan δ	Max leakage current	Case size
	(V _{dc})	(μ F) 1)	(m Ω) 2)	(mA rms) 3)		(mA) 4)	ϕ D \times L (mm)
2R5FP1200M	2.5	1,200	12	5,040	0.08	450.0	10 \times 10.5
4FP330M	4	330	24	3,230	0.07	132.0	10 \times 5
4FP560M	4	560	14	4,080	0.08	224.0	8 \times 10.5
4FP820M	4	820	12	5,040	0.08	328.0	10 \times 10.5
6FP220MA	6.3	220	20	3,160	0.08	138.6	6.3 \times 9.8
6FP220M	6.3	220	28	3,100	0.07	138.6	10 \times 5
6FP390M	6.3	390	16	3,810	0.08	245.7	8 \times 10.5
6FP680M	6.3	680	13	4,840	0.08	428.4	10 \times 10.5
10FP150M	10	150	30	2,990	0.07	150.0	10 \times 5
10FP270M	10	270	18	3,600	0.08	270.0	8 \times 10.5
10FP470M	10	470	15	4,510	0.08	470.0	10 \times 10.5
16FP100MA	16	100	25	2,820	0.08	160.0	6.3 \times 9.8
16FP100M	16	100	32	2,890	0.07	160.0	10 \times 5
16FP180M	16	180	20	3,410	0.08	288.0	8 \times 10.5
16FP270M	16	270	18	4,400	0.08	432.0	10 \times 10.5
20FP68MA	20	68	30	2,580	0.08	136.0	6.3 \times 9.8
20FP68M	20	68	34	2,800	0.07	136.0	10 \times 5
20FP120M	20	120	24	3,110	0.08	240.0	8 \times 10.5
20FP180M	20	180	20	4,280	0.08	360.0	10 \times 10.5

- Note 1) Tolerance on rated capacitance \pm 20%(M)
 2) ESR : 100kHz to 300kHz
 3) Rated ripple current : 100kHz, 45°C
 4) Max. leaked current : After 2 minutes.

◆CASE SIZE

μ F \ V _{dc}	2.5	4	6.3	10	16	20
68						6.3 \times 9.8 10 \times 5
100					6.3 \times 9.8 10 \times 5	
120						8 \times 10.5
150				10 \times 5		
180					8 \times 10.5	10 \times 10.5
220			6.3 \times 9.8 10 \times 5			
270				8 \times 10.5	10 \times 10.5	
330		10 \times 5				
390			8 \times 10.5			
470				10 \times 10.5		
560		8 \times 10.5				
680			10 \times 10.5			
820		10 \times 10.5				
1,200	10 \times 10.5					

◆TEMPERATURE MULTIPLYING FACTOR OF RATED RIPPLE CURRENT

Ambient temperature (°C)	to +45	to +65	to +85	to +95	to +105
Multiplying factor	1	0.85	0.7	0.4	0.25

"OS-CON" is SANYO ELECTRIC CO.,LTD. Trade Mark.



SOLID ELECTROLYTIC CAPACITORS WITH ORGANIC SEMICONDUCTOR

FX Series

- 105°C, 1000 hours
- Larger capacitance than FP series
- Low ESR same as FP series
- For VRM and DC-DC converter

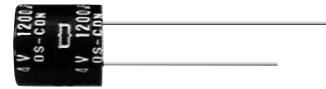

◆ SPECIFICATIONS

Items	Performance Requirements	
Category	-55 to +105°C	
Temperature Range	-55 to +105°C	
Rated Voltage Range	4 to 20Vdc	
Rated Capacitance Range	82 to 1,200μF (at 20°C, 120Hz)	
Tolerance on Rated Capacitance	±20% (M) (at 20°C, 120Hz)	
Leakage Current	I = 0.05CV (max.) I : Leakage current (μA), C : Rated capacitance (μF), V : rated voltage (Vdc) (at 20°C, 2 min)	
Dissipation Factor (tanδ)	See STANDARD RATINGS table (at 20°C, 120Hz)	
Characteristics at High and Low Temperature	Z (-55°C) / Z (20°C)	0.75 to 1.25 (at 100Hz)
	Z (105°C) / Z (20°C)	
Endurance	After 1000hours with applying rated voltage at 105°C, shall not exceed or within following values at 20°C.	
	Capacitance change	Within ±20% of the initial value
	tanδ	1.5 times of the initial specified value
	Leakage current	The initial specified value
Damp Heat, Steady State	After 1000hours with no load at 60°C, 90 to 95%RH, shall not exceed or within following values at 20°C. (after voltage treatment)	
	Capacitance change	Within ±20% of the initial value
	tanδ	2.0 times of the initial specified value
	Leakage current	The initial specified value

◆ DIMENSIONS

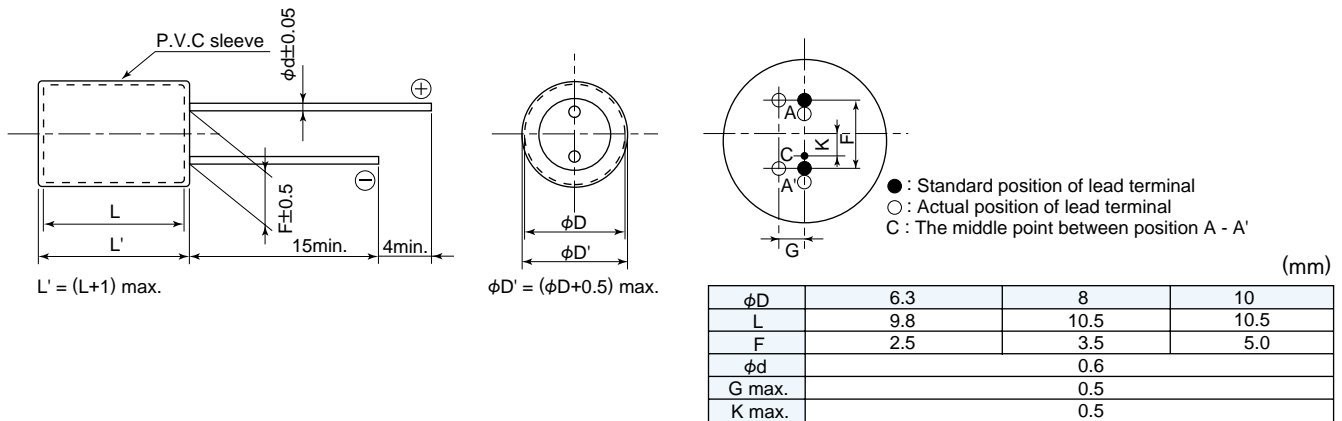

◆ PART NUMBERING SYSTEM

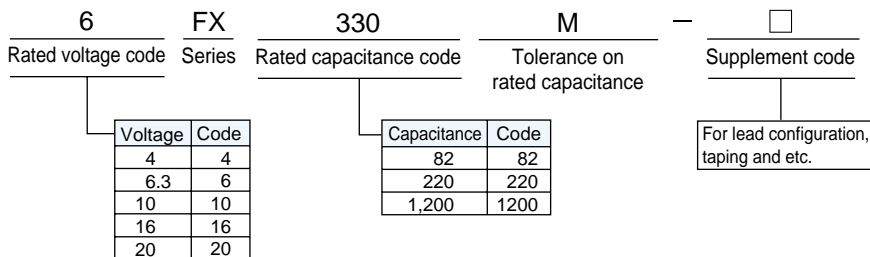

◆STANDARD RATINGS

Part No.	Rated voltage	Rated capacitance	Max ESR	Rated ripple current	Max tanδ	Max leakage current	Case size
	(V _{dc})	(μF) 1)	(mΩ) 2)	(mA rms) 3)		(μA) 4)	φD×L (mm)
4FX390M	4	390	24	3,300	0.11	78.0	6.3×9.8
4FX820M	4	820	14	4,200	0.12	164.0	8×10.5
4FX1200M	4	1,200	12	5,190	0.13	240.0	10×10.5
6FX330M	6.3	330	28	3,190	0.11	104.0	6.3×9.8
6FX680M	6.3	680	16	3,920	0.12	214.0	8×10.5
6FX1000M	6.3	1,000	13	4,935	0.13	315.0	10×10.5
10FX220M	10	220	30	3,080	0.09	110.0	6.3×9.8
10FX390M	10	390	18	3,710	0.10	195.0	8×10.5
10FX680M	10	680	15	4,735	0.11	340.0	10×10.5
16FX120M	16	120	32	2,985	0.08	96.0	6.3×9.8
16FX220M	16	220	20	3,510	0.08	176.0	8×10.5
16FX330M	16	330	18	4,530	0.09	264.0	10×10.5
20FX82M	20	82	34	2,880	0.07	82.0	6.3×9.8
20FX150M	20	150	24	3,200	0.08	150.0	8×10.5
20FX220M	20	220	20	4,405	0.09	220.0	10×10.5

- Note 1) Tolerance on rated capacitance ±20%(M)
 2) ESR : 100kHz to 300kHz
 3) Rated ripple current : 100kHz, 45°C
 4) Max. leakage current : After 2 minutes.

◆CASE SIZE

μF \ V _{dc}	4	6.3	10	16	20
82					6.3×9.8
120				6.3×9.8	
150					8×10.5
220			6.3×9.8	8×10.5	10×10.5
330		6.3×9.8		10×10.5	
390	6.3×9.8		8×10.5		
680		8×10.5	10×10.5		
820	8×10.5				
1,000		10×10.5			
1,200	10×10.5				

◆TEMPERATURE MULTIPLYING FACTOR OF RATED RIPPLE CURRENT

Ambient temperature (°C)	to +45	to +65	to +85	to +95	to +105
Multiplying factor	1	0.85	0.7	0.4	0.25



SOLID ELECTROLYTIC CAPACITORS WITH ORGANIC SEMICONDUCTOR

New!

FRA Series

- 105°C, 2000 hours
- Very low ESR
- Suitable for Bulk Capacitors for digital equipment

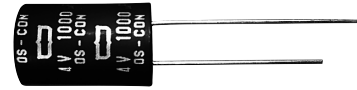

◆ SPECIFICATIONS

Items	Performance Requirements	
Category	-55 to +105°C	
Temperature Range	-55 to +105°C	
Rated Voltage Range	4Vdc	
Rated Capacitance Range	330 to 1,000μF (at 20°C, 120Hz)	
Tolerance on Rated Capacitance	±20% (M) (at 20°C, 120Hz)	
Leakage Current	I = 0.1CV (max.) I : Leakage current (μA), C : Rated capacitance (μF), V : rated voltage (Vdc) (at 20°C, 2 min)	
Dissipation Factor (tanδ)	See STANDARD RATINGS table (at 20°C, 120Hz)	
Characteristics at High and Low Temperature	Z (-55°C) / Z (20°C)	0.75 to 1.25 (at 100Hz)
	Z (105°C) / Z (20°C)	
Endurance	After 2 000hours with applying rated voltage at 105°C, shall not exceed or within following values at 20°C.	
	Capacitance change	Within ±20% of the initial value
	tanδ	1.5 times of the initial specified value
	Leakage current	The initial specified value
Damp Heat, Steady State	After 1000hours with no load at 60°C, 90 to 95%RH, shall not exceed or within following values at 20°C. (after voltage treatment)	
	Capacitance change	Within ±20% of the initial value
	tanδ	2.0 times of the initial specified value
	Leakage current	The initial specified value

◆ DIMENSIONS

$L' = (L+1) \text{ max.}$
 $\phi D' = (\phi D+0.5) \text{ max.}$

● : Standard position of lead terminal
 ○ : Actual position of lead terminal
 C : The middle point between position A - A'

	8	10	10
φD	8	10	10
L	10.5	10.5	16.0
F	3.5	5.0	5.0
φd	0.6		
G max.	0.5		
K max.	0.5		

◆ PART NUMBERING SYSTEM

4	FRA	330	M	□												
Rated voltage code	Series	Rated capacitance code	Tolerance on rated capacitance	Supplement code												
<table border="1"> <tr><th>Voltage</th><th>Code</th></tr> <tr><td>4</td><td>4</td></tr> </table>	Voltage	Code	4	4		<table border="1"> <tr><th>Capacitance</th><th>Code</th></tr> <tr><td>330</td><td>330</td></tr> <tr><td>560</td><td>560</td></tr> <tr><td>1,000</td><td>1000</td></tr> </table>	Capacitance	Code	330	330	560	560	1,000	1000		For lead configuration, taping and etc.
Voltage	Code															
4	4															
Capacitance	Code															
330	330															
560	560															
1,000	1000															



SOLID ELECTROLYTIC CAPACITORS WITH ORGANIC SEMICONDUCTOR

New!

FRA Series

◆STANDARD RATINGS

Part No.	Rated voltage	Rated capacitance	Max ESR	Rated ripple current	Max tanδ	Max leakage current	Case size
	(V _{dc})	(μF) 1)	(mΩ) 2)	(mA rms) 3)		(μA) 4)	φD×L (mm)
4FRA330M	4	330	10	4,300	0.08	132	8×10.5
4FRA560M	4	560	8	5,500	0.08	224	10×10.5
4FRA1000M	4	1,000	6	6,400	0.08	400	10×16

Note 1) Tolerance on rated capacitance ±20%(M)

2) ESR : 100kHz to 300kHz

3) Rated ripple current : 100kHz, 45°C

4) Max. leakage current : After 2 minutes.

◆CASE SIZE

μF \ V _{dc}	4
330	8×10.5
390	
470	
560	10×10.5
680	
820	
1,000	10×16

◆TEMPERATURE MULTIPLYING FACTOR OF RATED RIPPLE CURRENT

Ambient temperature (°C)	to +45	to +65	to +85	to +95	to +105
Multiplying factor	1	0.85	0.7	0.4	0.25

◆ ESR-FREQUENCY CHARACTERISTICS

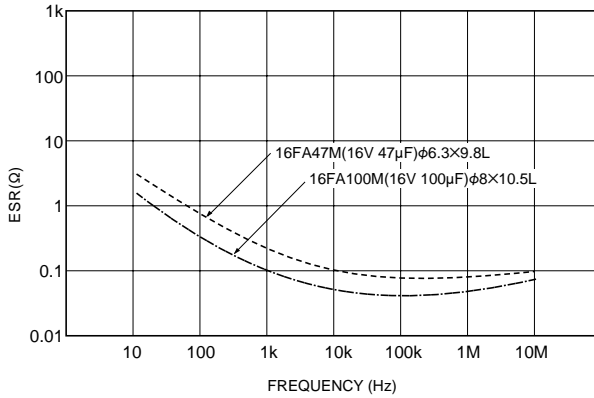

◆ IMPEDANCE-FREQUENCY CHARACTERISTICS

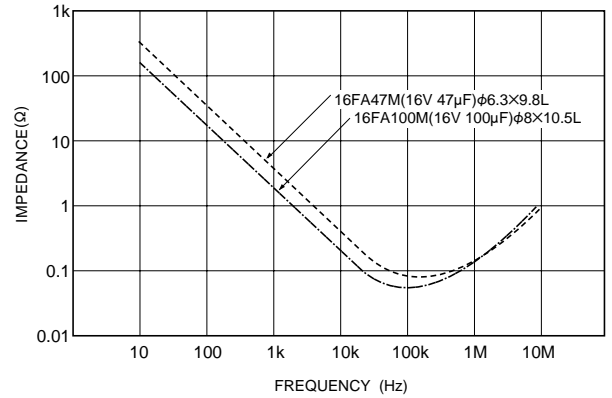

◆ TEMPERATURE CHARACTERISTICS (-55~+105°C)

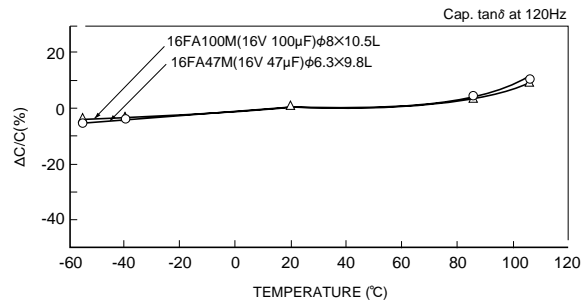

◆ ENDURANCE (105°C)

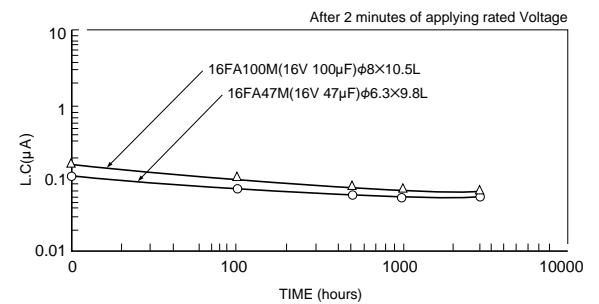
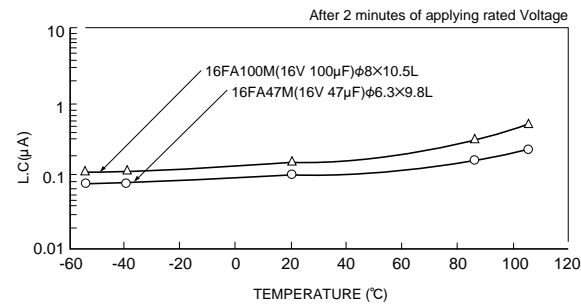
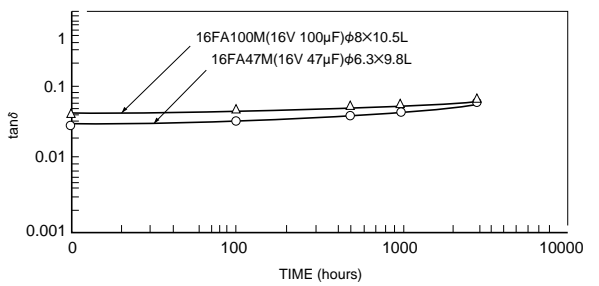
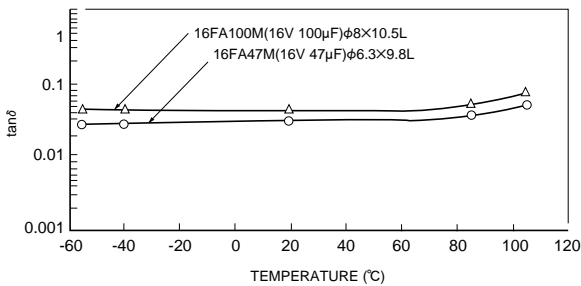
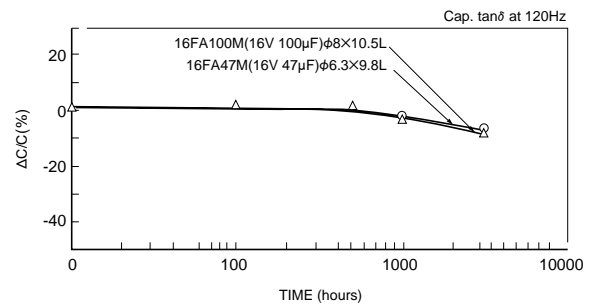

◆Presumption of Life time

The OS-CON™ has capacitance decrease in endurance test. From this, OS-CON™ will be open mode by capacitance decrease cause of wear-out in association with temperature.

The process of wear-out, capacitance decrease, is varied by ambient temperature and self-heating temperature from the flow of ripple current.

The estimated Life time L of an OS-CON™ at the ambient temperature T in which inside an unit, should be given by the following equation:

$$L = L_0 \times 10^{\frac{T_0 - \{T + (\frac{I}{I_0})^2 \Delta T\}}{20}}$$

- L : Presumption of Life time (hours) in actual use
(temperature T, ripple current I)
- L₀ : The guarantee of Life time (hours) at maximum operating temperature
- T₀ : Maximum operating temperature (°C)
- T : Ambient temperature (°C) inside an unit
- I : Actual flow of ripple current (A rms)
- I₀ : Rated ripple current at lower than 45°C (A rms)

Ambient temperature is higher than 45°C, rated ripple current should be multiplied by the factor given in follow table.

Ambient temperature (°C)	to +45	to +65	to +85	to +95	to +105
Factor	1.0	0.85	0.7	0.4	0.25

Self-heating temperature ΔT (°C) by rated ripple current of each case size is in follow table.

Case size	6.3×9.8	8×10.5	10×5, 10×10.5, 10×16
ΔT(°C)	16	18	20

The presumption of life time is reference value, cannot secure the performance of OS-CON™.

◆Application example

Kits and circuits	OS-CON™ Features	Electronic applications
Input and output for DC/DC-converter power sources	Smaller size Longer Life Greater cold-resistance	Video camera, MD, CD Digital camera
Filter circuits for switched power sources		VTR, PBX, Computer
Line and noise filters for CPUs and other ICs	Fewer ripples Cost down	Computer, PBX
Digital audio circuits for higher sound quality	Faster response Better reproduction	Hi-Fi VTR, MD, CD, TV
The backup capacitor of the power supply circuit of CPUs	Faster response For high frequency	Computer