

# THYRISTOR MODULE

## PK(PD,PE,KK)110F



UL:E76102 (M)

Power Thyristor/Diode Module PK110F series are designed for various rectifier circuits and power controls. For your circuit application, following internal connections and wide voltage ratings up to 1,600V are available. High precision 25mm (1inch) width package and electrically isolated mounting base make your mechanical design easy.

- $I_{T(AV)}$ 110A,  $I_{T(RMS)}$ 172A,  $I_{TSM}$  2550A
- $di/dt$  200 A/ $\mu$ s
- $dv/dt$  500V/ $\mu$ s

### (Applications)

Various rectifiers  
AC/DC motor drives  
Heater controls  
Light dimmers  
Static switches

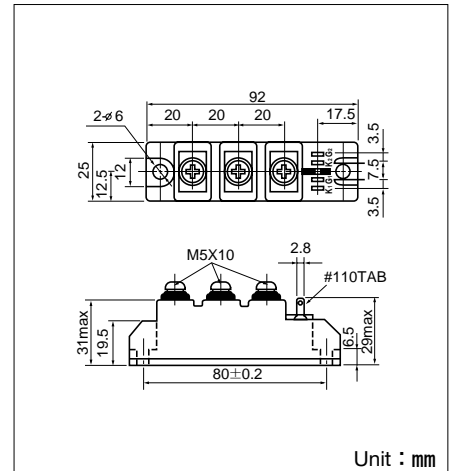
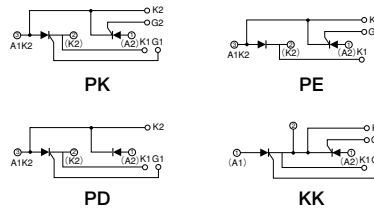

### Maximum Ratings

Symbol	Item	Ratings				Unit
		PK110F40 PD110F40 PE110F40 KK110F40	PK110F80 PD110F80 PE110F80 KK110F80	PK110F120 PD110F120 PE110F120 KK110F120	PK110F160 PD110F160 PE110F160 KK110F160	
VRRM	* Repetitive Peak Reverse Voltage	400	800	1200	1600	V
VRRM	* Non-Repetitive Peak Reverse Voltage	480	960	1300	1700	V
VDRM	Repetitive Peak Off-State Voltage	400	800	1200	1600	V

Symbol	Item	Conditions	Ratings	Unit	
$I_{T(AV)}$	* Average On-State Current	Single phase, half wave, 180° conduction, $T_c : 88^\circ\text{C}$	110	A	
$I_{T(RMS)}$	* R.M.S. On-State Current	Single phase, half wave, 180° conduction, $T_c : 88^\circ\text{C}$	172	A	
$I_{TSM}$	* Surge On-State Current	1/2 cycle, 50Hz/60Hz, peak Value, non-repetitive	2300/2550	A	
$I^2t$	* $I^2t$	Value for one cycle of surge current	26500	A <sup>2</sup> S	
$P_{GM}$	Peak Gate Power Dissipation		10	W	
$P_{G(AV)}$	Average Gate Power Dissipation		3	W	
$I_{FGM}$	Peak Gate Current		3	A	
$V_{FGM}$	Peak Gate Voltage(Forward)		10	V	
$V_{RGM}$	Peak Gate Voltage(Reverse)		5	V	
$di/dt$	Critical Rate of Rise of On-State Current	$I_G=100\text{mA}$ , $T_j=25^\circ\text{C}$ , $V_D=1/2V_{DRM}$ , $di_G/dt=0.1\text{A}/\mu\text{s}$	200	A/ $\mu$ s	
$V_{ISO}$	* Isolation Breakdown Voltage (R.M.S.)	A.C.1minute	2500	V	
$T_j$	* Operating Junction Temperature		-40 to +125	°C	
$T_{stg}$	* Storage Temperature		-40 to +125	°C	
	Mounting Torque	Mounting (M5)	Recommended 1.5-2.5 (15-25)	2.7 (28)	N·m (kgf·cm)
		Terminal (M5)	Recommended 1.5-2.5 (15-25)	2.7 (28)	
	Mass		170	g	

### Electrical Characteristics

Symbol	Item	Conditions	Ratings	Unit
$I_{DRM}$	Repetitive Peak Off-State Current, max.	at $V_{DRM}$ , single phase, half wave, $T_j=125^\circ\text{C}$	20	mA
$I_{RRM}$	* Repetitive Peak Reverse Current, max.	at $V_{DRM}$ , single phase, half wave, $T_j=125^\circ\text{C}$	20	mA
$V_{TM}$	* Peak On-State Voltage, max.	On-State Current 350A, $T_j=25^\circ\text{C}$ Inst. measurement	1.45	V
$I_{GT}/V_{GT}$	Gate Trigger Current/Voltage, max.	$T_j=25^\circ\text{C}$ , $I_T=1\text{A}$ , $V_D=6\text{V}$	100/3	mA/V
$V_{GD}$	Non-Trigger Gate, Voltage. min.	$T_j=125^\circ\text{C}$ , $V_D=1/2V_{DRM}$	0.25	V
$t_{gt}$	Turn On Time, max.	$I_T=110\text{A}$ , $I_G=100\text{mA}$ , $T_j=25^\circ\text{C}$ , $V_D=1/2V_{DRM}$ , $di_G/dt=0.1\text{A}/\mu\text{s}$	10	$\mu$ s
$dv/dt$	Critical Rate of Rise of Off-State Voltage, min.	$T_j=125^\circ\text{C}$ , $V_D=2/3V_{DRM}$ , Exponential wave.	500	V/ $\mu$ s
$I_H$	Holding Current, typ.	$T_j=25^\circ\text{C}$	50	mA
$I_L$	Latching Current, typ.	$T_j=25^\circ\text{C}$	100	mA
$R_{th(j-c)}$	* Thermal Impedance, max.	Junction to case	0.25	°C/W

\* mark : Thyristor and Diode part. No mark : Thyristor part

