

THYRISTOR MODULE

PK(PD,PE)25FG

TOP



UL;E76102 (M)

Power Thyristor/Diode Module PK25FG series are designed for various rectifier circuits and power controls. For your circuit application, following internal connections and wide voltage ratings up to 1600V are available. and electrically isolated mounting base make your mechanical design easy.

- $I_{T(AV)}$ 25A, $I_{T(RMS)}$ 39A, I_{TSM} 700A
- di/dt 100A/ μ s
- dv/dt 1000V/ μ s

(Applications)

Various rectifiers
AC/DC motor drives
Heater controls
Light dimmers
Static switches

Internal Configurations

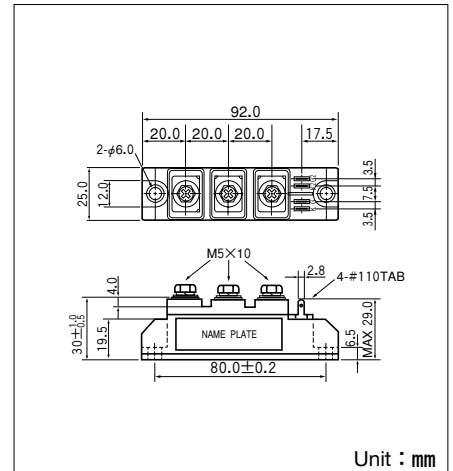
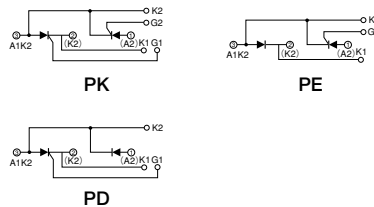

Maximum Ratings

($T_j=25^\circ\text{C}$ unless otherwise specified)

| Symbol | Item | Ratings | | | | Unit |
|-----------|---------------------------------------|----------------------------------|----------------------------------|-------------------------------------|-------------------------------------|------|
| | | PK25FG40 PD25FG40 PE25FG40 | PK25FG80 PD25FG80 PE25FG80 | PK25FG120 PD25FG120 PE25FG120 | PK25FG160 PD25FG160 PE25FG160 | |
| V_{RRM} | * Repetitive Peak Reverse Voltage | 400 | 800 | 1200 | 1600 | V |
| V_{RSM} | * Non-Repetitive Peak Reverse Voltage | 480 | 960 | 1300 | 1700 | V |
| V_{DRM} | Repetitive Peak off-state Voltage | 400 | 800 | 1200 | 1600 | V |

| Symbol | Item | Conditions | Ratings | Unit | |
|--------------|---|---|-----------------------------------|------------------|-----------------|
| $I_{T(AV)}$ | * Average On-state Current | Single phase, half wave, 180° conduction, $T_c=81^\circ\text{C}$ | 25 | A | |
| $I_{T(RMS)}$ | * R.M.S. On-state Current | Single phase, half wave, 180° conduction, $T_c=81^\circ\text{C}$ | 39 | A | |
| I_{TSM} | * Surge On-state Current | 1/2 Cycle, 50/60Hz, Peak Value, non-repetitive | 640/700 | A | |
| I^2t | * I^2t | Value for one cycle surge current | 2870 | A 2 S | |
| P_{GM} | Peak Gate Power Dissipation | | 10 | W | |
| $P_{G(AV)}$ | Average Gate Power Dissipation | | 1 | W | |
| I_{FGM} | Peak Gate Current | | 3 | A | |
| V_{FGM} | Peak Gate Voltage (Forward) | | 10 | V | |
| V_{RGM} | Peak Gate Voltage (Reverse) | | 5 | V | |
| di/dt | Critical Rate of Rise of On-state Current | $I_G=100\text{mA}$, $V_D=1/2V_{DRM}$, $di/dt=0.1\text{A}/\mu\text{s}$ | 100 | A/ μs | |
| V_{ISO} | * Isolation Breakdown Voltage (R.M.S.) | A.C. 1minute | 2500 | V | |
| T_j | * Operating Junction Temperature | | -40 to +125 | $^\circ\text{C}$ | |
| T_{stg} | * Storage Temperature | | -40 to +125 | $^\circ\text{C}$ | |
| | Mounting Torque | Mounting (M5) | Recommended Value 1.5-2.5 (15-25) | 2.7 (28) | N·m (kgf·cm) |
| | | Terminal (M5) | Recommended Value 1.5-2.5 (15-25) | 2.7 (28) | |
| | Mass | Typical Value | 170 | g | |

Electrical Characteristics

| Symbol | Item | Conditions | Ratings | Unit |
|---------------|--|--|---------|---------------------------|
| I_{DRM} | Repetitive Peak off-state Current,max | $T_j=125^\circ\text{C}$, $V_D=V_{DRM}$ | 5 | mA |
| I_{RRM} | * Repetitive Peak Reverse Current,max | $T_j=125^\circ\text{C}$, $V_D=V_{DRM}$ | 5 | mA |
| V_{TM} | * On-state Voltage,max | $I_T=75\text{A}$ | 1.6 | V |
| I_{GT} | Gate Trigger Current,max | $V_D=6\text{V}$, $I_T=1\text{A}$ | 50 | mA |
| V_{GT} | Gate Trigger Voltage,max | $V_D=6\text{V}$, $I_T=1\text{A}$ | 3 | V |
| V_{GD} | Gate Non-Trigger Voltage,min | $T_j=125^\circ\text{C}$, $V_D=1/2V_{DRM}$ | 0.25 | V |
| dv/dt | Critical Rate of Rise of off-state Voltage,min | $T_j=125^\circ\text{C}$, $V_D=2/3V_{DRM}$ | 1000 | V/ μs |
| $R_{th(j-c)}$ | * Thermal Impedance,max | Junction to case | 1.1 | $^\circ\text{C}/\text{W}$ |

* mark : Thyristor and Diode part. No mark : Thyristor part

