

PF08103A

MOS FET Power Amplifier Module
for E-GSM900 and DCS1800 Dual Band Handy Phone

HITACHI

ADE-208-685C (Z)
4th Edition
Jan. 2001

Application

- Dual band amplifier for E-GSM900 (880 MHz to 915 MHz) and DCS1800 (1710 MHz to 1785 MHz).
- For 4.8 V nominal battery use

Features

- 1 in / 2 out dual band amplifier
- Simple external circuit including output matching circuit
- Simple band switching and power control
- High gain 3stage amplifier : +4.5 dBm input
- Lead less thin & Small package : $11 \times 13.75 \times 1.8$ mm
- High efficiency : 48 % Typ at 34.5 dBm for E-GSM
36 % Typ at 31.5 dBm for DCS1800

Pin Arrangement

- RF-O

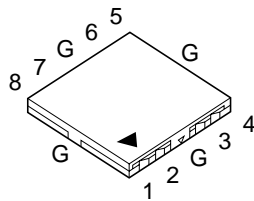

- 1: $\sqrt{V_{CTL}}$
- 2: V_{CTL}
- 3: Vdd2
- 4: Pout_{GSM}
- 5: Pout_{DCS}
- 6: Vdd1
- 7: Vapc
- 8: Pin
- G: GND

Internal Circuit Block Diagram

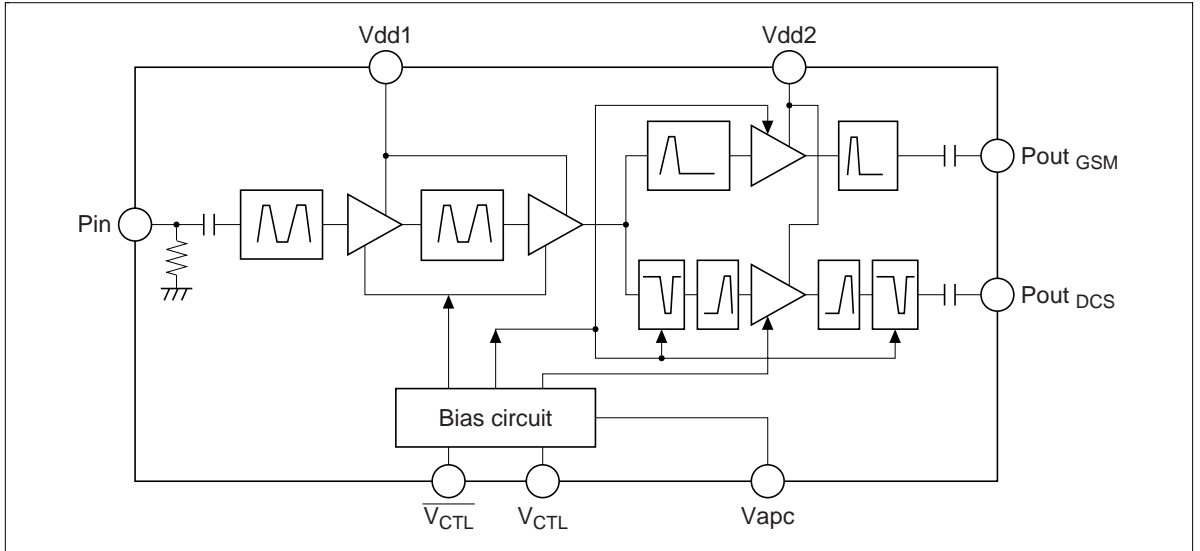

Band Select and Power Control (H: 2 V Min, L: 0.3 V Max)

Operating Mode	V_{CTL}	$\overline{V_{CTL}}$	V_{apc}
GSM Tx ON	H	L	Control
DCS Tx ON	L	H	Control
Tx OFF	L	L	< 0.2 V

Current of Control Pin

Control Pin	Equivalent Input Circuit	Control Current
V_{CTL}		160 μ A Max at 3 V
$\overline{V_{CTL}}$		80 μ A Max at 3 V
V_{apc}		3 mA Max at 3 V

Internal Diagram and External Circuit

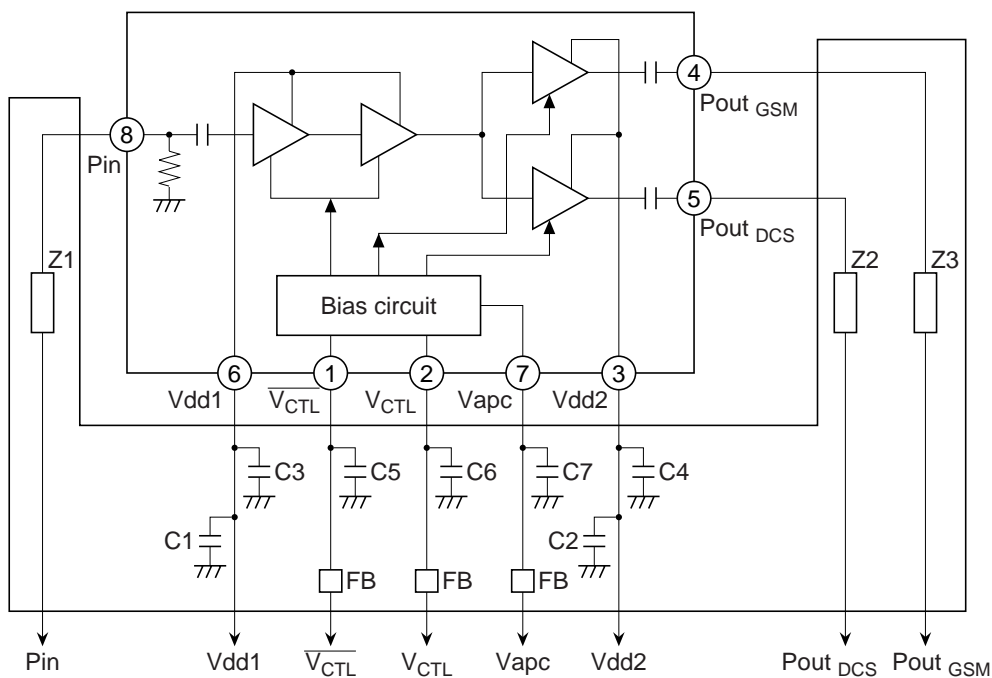

Note: C1 = C2 = 4.7 μ F TANTALUM ELECTROLYTE
 C3 = C4 = 0.01 μ F CERAMIC CHIP
 C5 = C6 = C7 = 1000 pF CERAMIC CHIP
 FB = FERRITE BEAD BLO1RN1-A62-001 (MURATA) or equivalent
 Z1 = Z2 = Z3 = 50 Ω MICRO STRIP LINE

Absolute Maximum Ratings ($T_c = 25^\circ\text{C}$)

Item	Symbol	Rating	Unit
Supply voltage	V_{DD}	8.5	V
Supply current	$I_{DD\text{ GSM}}$	3	A
	$I_{DD\text{ DCS}}$	3	A
V_{CTL} , $\overline{V_{CTL}}$ voltage	V_{CTL} , $\overline{V_{CTL}}$	4	V
Vapc voltage	V_{apc}	4	V
Input power	P_{in}	10	dBm
Operating case temperature	T_c (op)	-30 to +100	$^\circ\text{C}$
Storage temperature	T_{stg}	-30 to +100	$^\circ\text{C}$
Output power	$P_{out\text{ GSM}}$	5	W
	$P_{out\text{ DCS}}$	3	W

Note: The maximum ratings shall be valid over both the E-GSM-band (880 MHz -915 MHz), and the DCS-band (1710 MHz -1785 MHz).

Electrical Characteristics for DC ($T_c = 25^\circ\text{C}$)

Item	Symbol	Min	Typ	Max	Unit	Test Condition
Drain cutoff current	I_{ds}	—	—	20	μA	$V_{dd} = 6.0\text{ V}$, $V_{apc} = 0\text{ V}$, $V_{CTL} = 0\text{ V}$, $\overline{V_{CTL}} = 0\text{ V}$
		—	—	300	μA	$V_{dd} = 8.5\text{ V}$, $V_{apc} = 0\text{ V}$, $V_{CTL} = 0\text{ V}$, $\overline{V_{CTL}} = 0\text{ V}$, $T_c = -20\text{ to }+80^\circ\text{C}$
V_{CTL} control current	I_{CTL}	—	100	160	μA	$V_{CTL} = 3.0\text{ V}$
$\overline{V_{CTL}}$ control current	$\overline{I_{CTL}}$	—	50	80	μA	$\overline{V_{CTL}} = 3.0\text{ V}$

Electrical Characteristics for GSM900 mode (T_c = 25°C)

Test conditions unless otherwise noted:

f = 880 to 915MHz, V_{dd1} = V_{dd2} = 4.8V, Pin = +4.5dBm, V_{CTL} = 2.0V, $\overline{V_{CTL}} = 0.3V$, R_g = R_l = 50Ω, T_c = 25°C, Pulse operation with pulse width 577 μs and duty cycle 1:8 shall be used.

Item	Symbol	Min	Typ	Max	Unit	Test Condition
Frequency range	f	880	—	915	MHz	
Control voltage range	V _{apc}	0.2	—	3.0	V	
V _{apc} control current	I _{apc}	—	—	3	mA	V _{apc} = 3.0V
Total efficiency	η _T	43	48	—	%	P _{out GSM} = 34.5dBm,
2nd harmonic distortion	2nd H.D.	—	-45	-35	dBc	V _{apc} = control
3rd harmonic distortion	3rd H.D.	—	-45	-35	dBc	
4th~8th harmonic distortion	4th~8th H.D.	—	—	-35	dBc	
Input VSWR	VSWR (in)	—	2	3	—	
Output power (1)	P _{out} (1)	34.5	35.7	—	dBm	V _{apc} = 3.0V
Output power (2)	P _{out} (2)	33.0	34.0	—	dBm	V _{dd} = 4.2V, V _{apc} = 3.0V, T _c = +85°C, Pin = +3dBm
Isolation	—	—	-40	-20	dBm	V _{apc} = 0.2 V
Isolation at DCS RF-output when GSM is active	—	—	-30	-20	dBm	P _{out GSM} = 34.5dBm (GSM mode) Measured at f = 1760 to 1830MHz
Switching time	t _r , t _f	—	1	2	μs	P _{out GSM} = -15 to 35.0dBm
Stability	—	No parasitic oscillation All spurious < -36 dBm			—	V _{DD} = 4.2 to 6.3V, P _{out} ≤ 35.0dBm, V _{apc} ≤ 3.0V GSM pulse. R _g = 50Ω, T _c = -20 to +85°C, Output VSWR = 6 : 1 All phases, RES BW = 3MHz
Load VSWR tolerance	—	No degradation or Permanent degradation			—	V _{DD} = 4.2 to 6.3V, P _{out GSM} ≤ 35.0dBm, V _{apc} ≤ 3.0V GSM pulse. R _g = 50Ω, t = 30sec., T _c = -20 to +85°C, Output VSWR = 10 : 1 All phases
Noise power	P _{noise1}	—	—	-73	dBm	f ₀ = 915MHz, fr _x = f ₀ +10MHz P _{out GSM} = 35dBm, RES BW = 100kHz
	P _{noise2}	—	—	-85	dBm	f ₀ = 915MHz, fr _x = f ₀ +20MHz P _{out GSM} = 35dBm, RES BW = 100kHz
	P _{noise3}	—	—	-77	dBm	fr _x = 1805 to 1880MHz P _{out GSM} = 35dBm, RES BW = 100kHz
Slope P _{out} /V _{apc}	—	—	—	200	dB/V	P _{out GSM} = 0 to 35dBm

Electrical Characteristics for DCS1800 mode (Tc = 25°C)

Test conditions unless otherwise noted:

f = 1710 to 1785MHz, Vdd1 = Vdd2 = 4.8V, Pin = +4.5dBm, V_{CTL} = 0.3V, $\overline{V_{CTL}} = 2.0V$, Rg = Rl = 50Ω, Tc = 25°C, Pulse operation with pulse width 577 μs and duty cycle 1:8 shall be used.

Item	Symbol	Min	Typ	Max	Unit	Test Condition
Frequency range	f	1710	—	1785	MHz	
Control voltage range	Vapc	0.2	—	3.0	V	
Vapc control current	Iapc	—	—	3	mA	Vapc = 3.0V
Total efficiency	η _T	33	36	—	%	Pout _{DCS} = 31.5dBm,
2nd harmonic distortion	2nd H.D.	—	-45	-35	dBc	Vapc = control
3rd harmonic distortion	3rd H.D.	—	-45	-35	dBc	
4th~8th harmonic distortion	4th~8th H.D.	—	—	-35	dBc	
Input VSWR	VSWR (in)	—	3	5	—	
Output power (1)	Pout (1)	31.5	33.0	—	dBm	Vapc = 3.0V
Output power (2)	Pout (2)	31	31.5	—	dBm	Vdd = 4.8V, Vapc = 3.0V, Tc = +85°C, Pin = +3dBm
Isolation	—	—	-35	-30	dBm	Vapc = 0.2V
Switching time	t _r , t _f	—	1	2	μs	Pout _{DCS} = -15 to 32.0dBm
Stability	—	No parasitic oscillation			—	V _{DD} = 4.2 to 6.3V, Pout _{DCS} ≤ 32.5dBm, Vapc ≤ 3.0V DCS pulse. Rg = 50Ω, Tc = -20 to +85°C, Output VSWR = 6 : 1 All phases
Load VSWR tolerance	—	No degradation			—	V _{DD} = 4.2 to 6.3V, Pout _{DCS} ≤ 32.5dBm, Vapc ≤ 3.0V DCS pulse. Rg = 50Ω, t = 30sec., Tc = -20 to +85°C, Output VSWR = 10 : 1 All phases
Noise power	Pnoise1	—	—	-77	dBm	f0 = 1785MHz, frx = f0 +20MHz, Pout _{DCS} = 31.5dBm, RES BW = 30kHz
	Pnoise2	—	—	-74	dBm	frx = 925 to 935MHz, Pout _{DCS} = 31.5dBm, RES BW = 30kHz
	Pnoise3	—	—	-85	dBm	frx = 935 to 960MHz, Pout _{DCS} = 31.5dBm, RES BW = 30kHz
Slope Pout/Vapc	—	—	—	200	dB/V	Pout _{DCS} = 0 to 32.0dBm
Intermodulation	—	—	—	-20	dBm	Pout = 31.5dBm, Interferer.CW f0 +800kHz, Pinterfer = -9dBm, RES BW = 300kHz, Measure at f0 -800kHz

Characteristic Curves

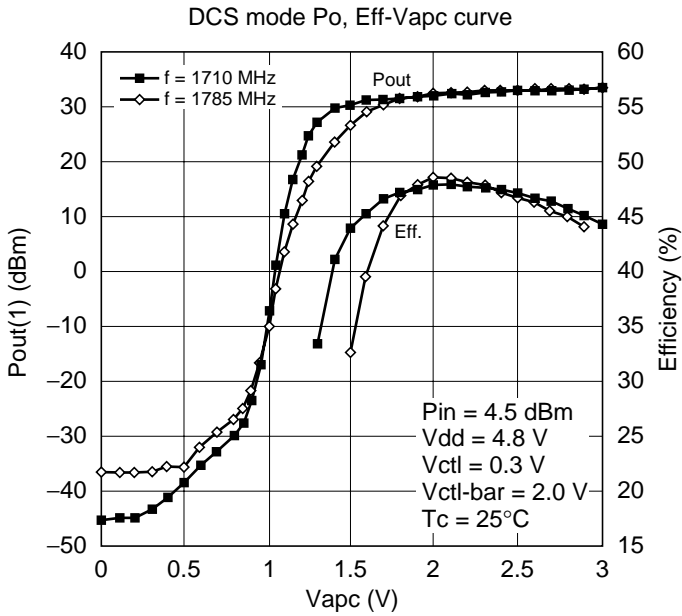
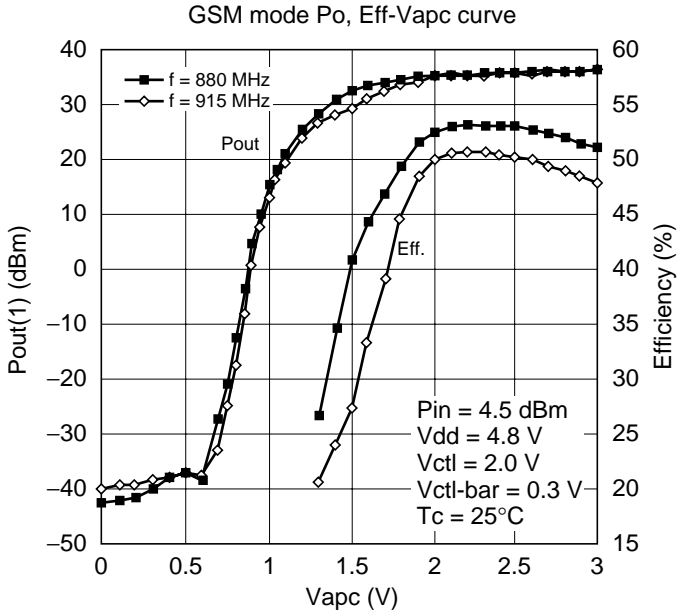

GSM mode Po-Pin curve

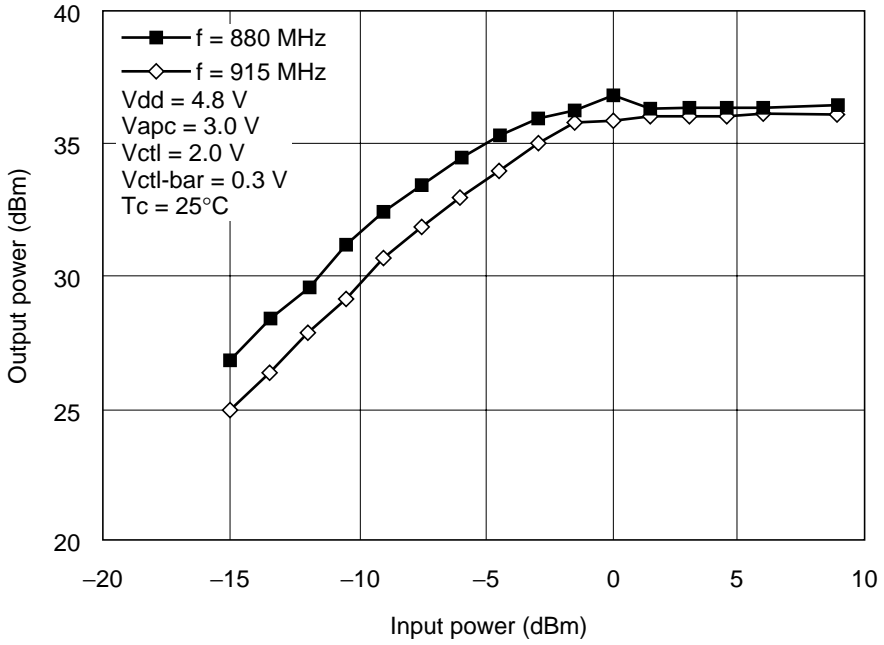

GSM mode Eff-pin curve

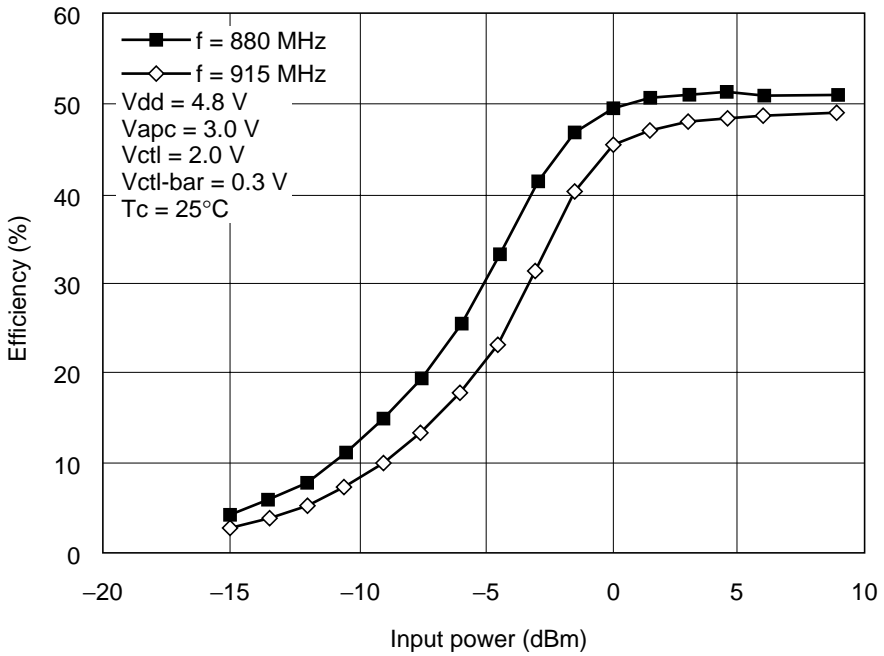

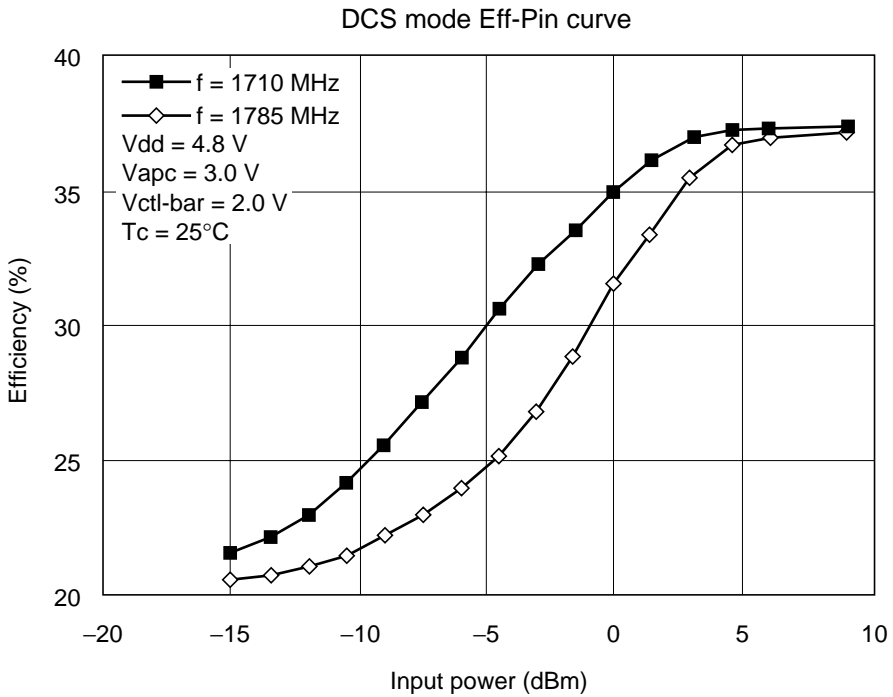
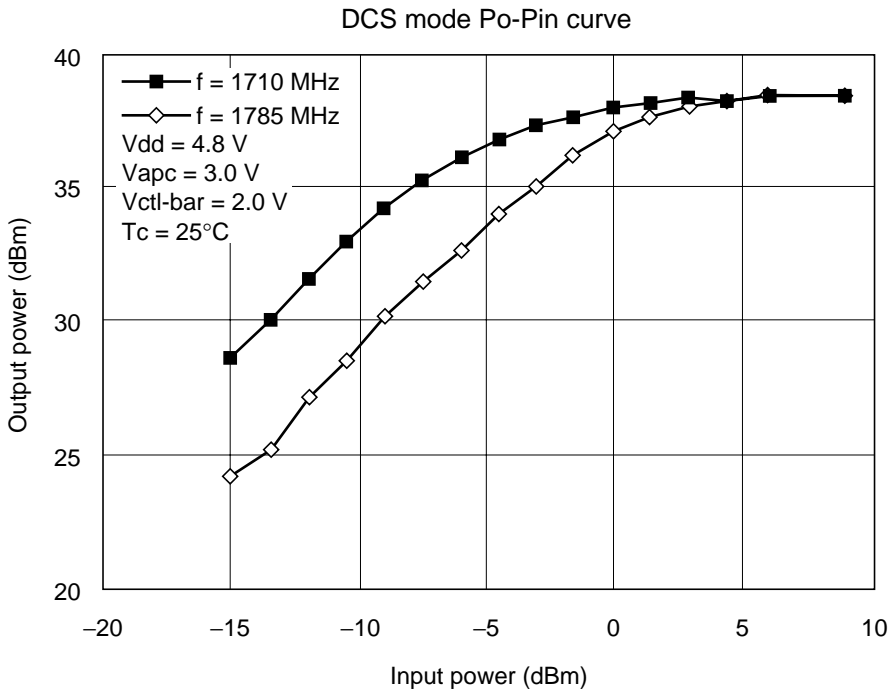

GSM mode Po-Vdd curve

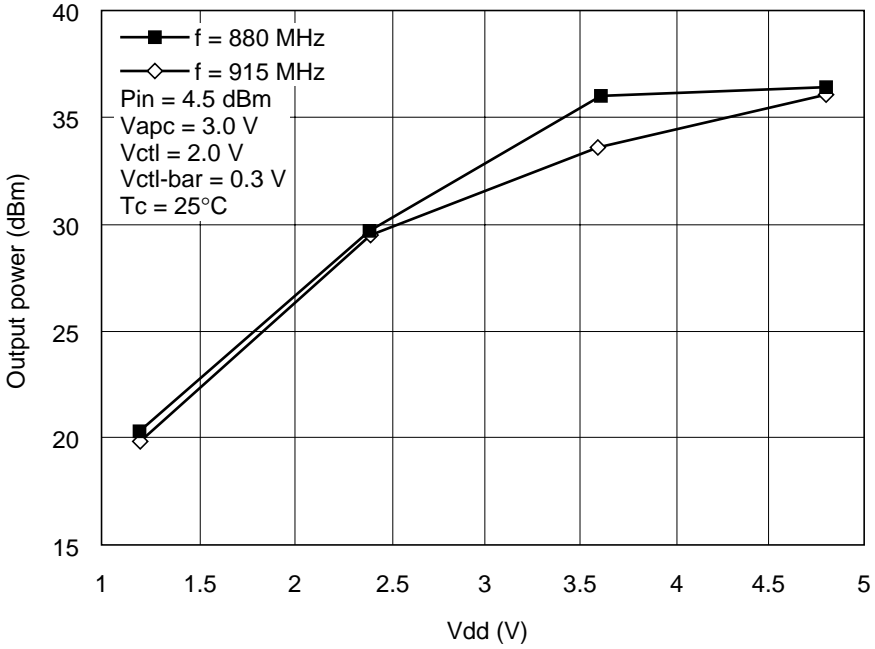

GSM mode Eff-Vdd curve

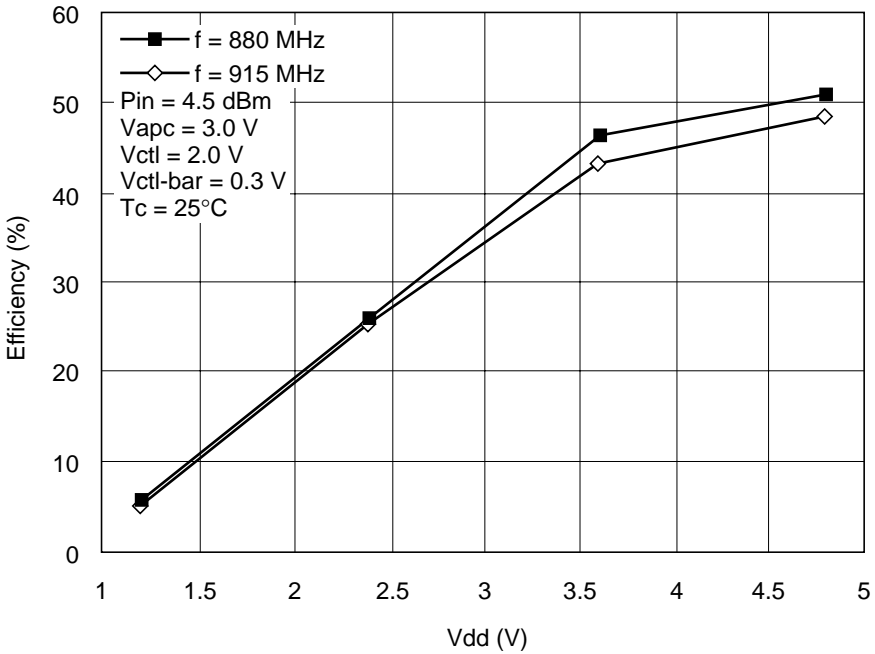

DCS mode Po-Vdd curve

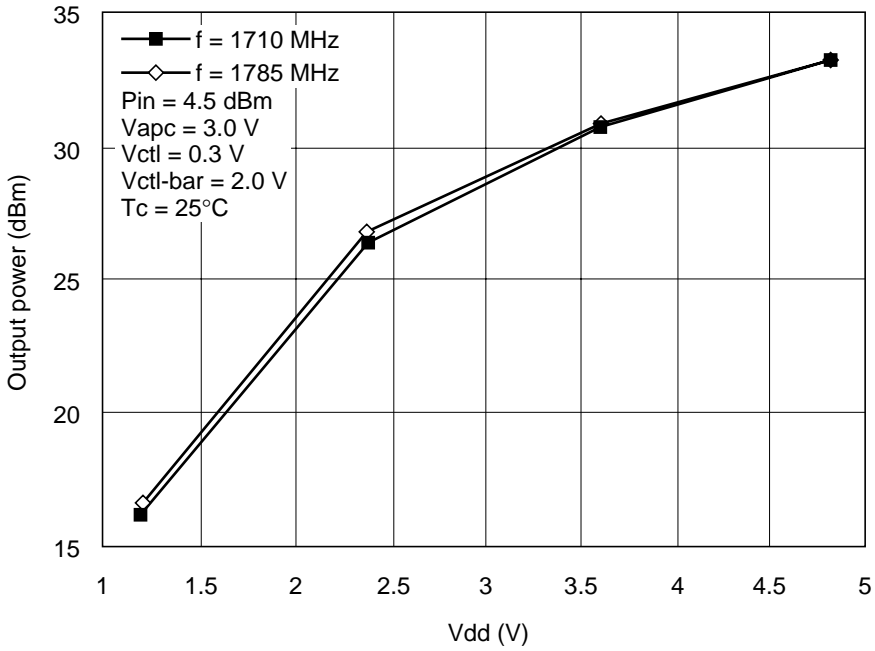

DCS mode Eff-Vdd curve

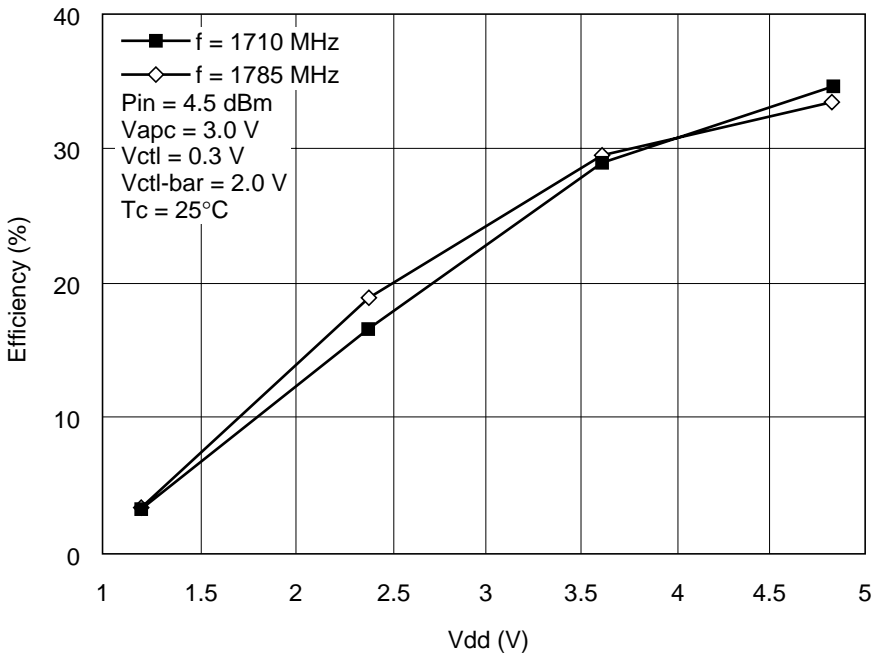

Package Dimensions

Unit: mm

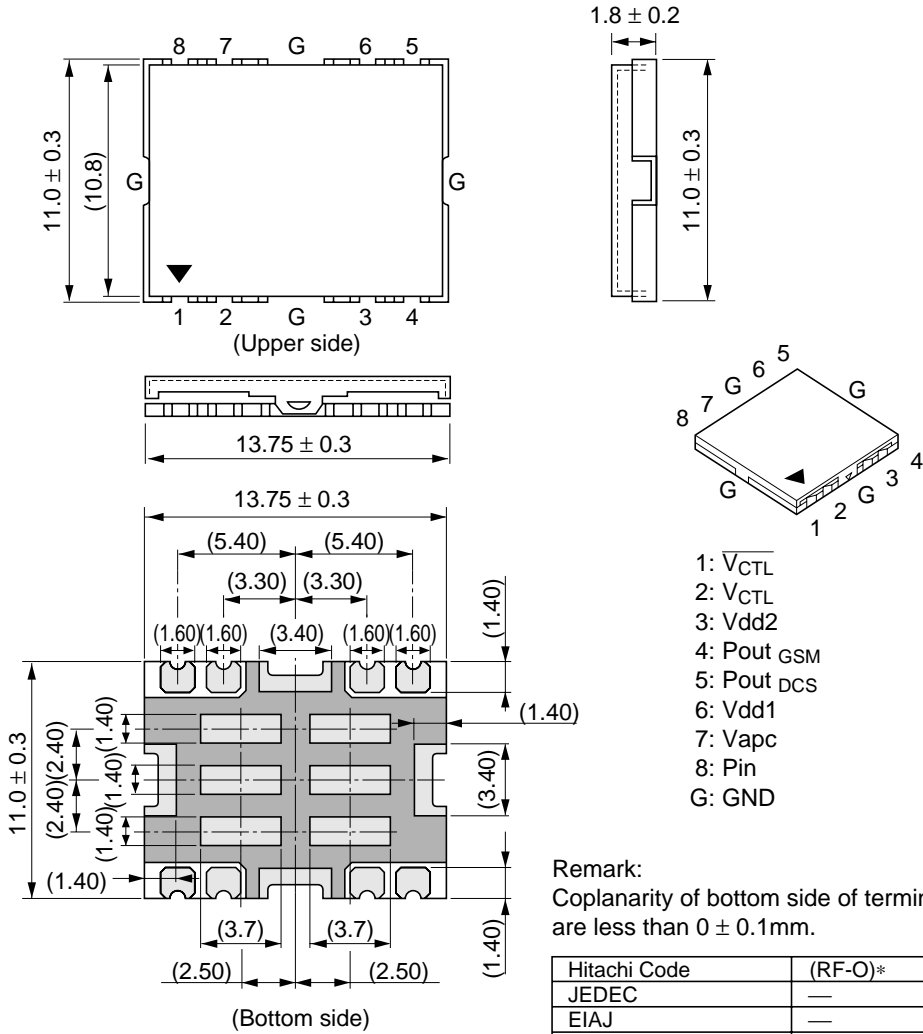

Hitachi Code	(RF-O)*
JEDEC	—
EIAJ	—
Mass (reference value)	—

Cautions

1. Hitachi neither warrants nor grants licenses of any rights of Hitachi's or any third party's patent, copyright, trademark, or other intellectual property rights for information contained in this document. Hitachi bears no responsibility for problems that may arise with third party's rights, including intellectual property rights, in connection with use of the information contained in this document.
2. Products and product specifications may be subject to change without notice. Confirm that you have received the latest product standards or specifications before final design, purchase or use.
3. Hitachi makes every attempt to ensure that its products are of high quality and reliability. However, contact Hitachi's sales office before using the product in an application that demands especially high quality and reliability or where its failure or malfunction may directly threaten human life or cause risk of bodily injury, such as aerospace, aeronautics, nuclear power, combustion control, transportation, traffic, safety equipment or medical equipment for life support.
4. Design your application so that the product is used within the ranges guaranteed by Hitachi particularly for maximum rating, operating supply voltage range, heat radiation characteristics, installation conditions and other characteristics. Hitachi bears no responsibility for failure or damage when used beyond the guaranteed ranges. Even within the guaranteed ranges, consider normally foreseeable failure rates or failure modes in semiconductor devices and employ systemic measures such as fail-safes, so that the equipment incorporating Hitachi product does not cause bodily injury, fire or other consequential damage due to operation of the Hitachi product.
5. This product is not designed to be radiation resistant.
6. No one is permitted to reproduce or duplicate, in any form, the whole or part of this document without written approval from Hitachi.
7. Contact Hitachi's sales office for any questions regarding this document or Hitachi semiconductor products.

HITACHI

Hitachi, Ltd.

Semiconductor & Integrated Circuits.

Nippon Bldg., 2-6-2, Ohte-machi, Chiyoda-ku, Tokyo 100-0004, Japan
Tel: Tokyo (03) 3270-2111 Fax: (03) 3270-5109

URL	NorthAmerica	: http://semiconductor.hitachi.com/
	Europe	: http://www.hitachi-eu.com/hel/ecg
	Asia	: http://sicapac.hitachi-asia.com
	Japan	: http://www.hitachi.co.jp/Sicd/indx.htm

For further information write to:

Hitachi Semiconductor
(America) Inc.
179 East Tasman Drive,
San Jose, CA 95134
Tel: <1> (408) 433-1990
Fax: <1>(408) 433-0223

Hitachi Europe GmbH
Electronic Components Group
Dornacher StraÙe 3
D-85622 Feldkirchen, Munich
Germany
Tel: <49> (89) 9 9180-0
Fax: <49> (89) 9 29 30 00

Hitachi Europe Ltd.
Electronic Components Group.
Whitebrook Park
Lower Cookham Road
Maidenhead
Berkshire SL6 8YA, United Kingdom
Tel: <44> (1628) 585000
Fax: <44> (1628) 585160

Hitachi Asia Ltd.
Hitachi Tower
16 Collyer Quay #20-00,
Singapore 049318
Tel: <65>-538-6533/538-8577
Fax : <65>-538-6933/538-3877
URL : <http://www.hitachi.com.sg>

Hitachi Asia Ltd.
(Taipei Branch Office)
4/F, No. 167, Tun Hwa North Road,
Hung-Kuo Building,
Taipei (105), Taiwan
Tel: <886>-(2)-2718-3666
Fax : <886>-(2)-2718-8180
Telex : 23222 HAS-TP
URL : <http://www.hitachi.com.tw>

Hitachi Asia (Hong Kong) Ltd.
Group III (Electronic Components)
7/F., North Tower,
World Finance Centre,
Harbour City, Canton Road
Tsim Sha Tsui, Kowloon,
Hong Kong
Tel : <852>-(2)-735-9218
Fax : <852>-(2)-730-0281
URL : <http://www.hitachi.com.hk>

Copyright © Hitachi, Ltd., 2001. All rights reserved. Printed in Japan.
Colophon 2.0

HITACHI