

PHP7NQ60E; PHX7NQ60E

N-channel enhancement mode field-effect transistor

Rev. 01 — 20 August 2002

Product data

1. Description

N-channel, enhancement mode field-effect power transistor.

Product availability:

PHP7NQ60E in TO-220AB (SOT78)

PHX7NQ60E in isolated TO-220AB.

2. Features

- Very fast switching
- Available in plastic and plastic full-pack package
- Low thermal resistance.

3. Applications

- DC to DC converters
- Switched mode power supplies
- Electronic lighting ballasts
- T.V. and computer monitor power supplies.

4. Pinning information

Table 1: Pinning - TO-220AB and isolated TO-220AB, simplified outline and symbol

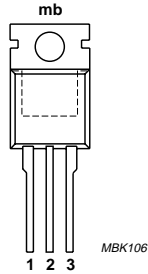
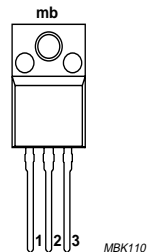
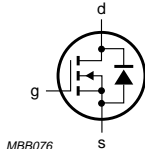
Pin	Description	Simplified outline	Symbol	
1	gate (g)			
2	drain (d)			
3	source (s)			
mb (TO-220AB only)	mounting base, connected to drain (d)	TO-220AB (SOT78)	isolated TO-220AB	

5. Quick reference data

Table 2: Quick reference data

Symbol	Parameter	Conditions	Typ	Max	Unit
V_{DS}	drain-source voltage (DC)	$25\text{ °C} \leq T_j \leq 150\text{ °C}$	-	600	V
I_D	drain current (DC)	$T_c = 25\text{ °C}; V_{GS} = 10\text{ V}$	[1]	7	A
T_j	junction temperature		-	150	°C
$R_{DS(on)}$	drain-source on-state resistance	$V_{GS} = 10\text{ V}; I_D = 3.5\text{ A}$			
		$T_j = 25\text{ °C}$	0.94	1.2	Ω
		$T_j = 150\text{ °C}$	2.4	2.9	Ω

6. Limiting values

Table 3: Limiting values

Symbol	Parameter	Conditions	Min	Max	Unit
V_{DS}	drain-source voltage (DC)	$25\text{ °C} \leq T_j \leq 150\text{ °C}$	-	600	V
V_{DGR}	drain-gate voltage (DC)	$25\text{ °C} \leq T_j \leq 150\text{ °C}; R_{GS} = 20\text{ k}\Omega$	-	600	V
V_{GS}	gate-source voltage (DC)		-	± 30	V
I_D	drain current (DC)	$T_c = 25\text{ °C}; V_{GS} = 10\text{ V};$	[1]	7	A
		$T_c = 100\text{ °C}; V_{GS} = 10\text{ V};$ Figure 3 and 4	[1]	4.5	A
I_{DM}	peak drain current	$T_c = 25\text{ °C};$ pulsed; $t_p \leq 10\text{ }\mu\text{s};$ Figure 5 and 6	-	28	A
P_{tot}	total power dissipation (TO-220AB)	$T_c = 25\text{ °C};$ Figure 1	-	147	W
P_{tot}	total power dissipation (isolated TO-220AB)	$T_c = 25\text{ °C};$ Figure 2	-	37	W
T_{stg}	storage temperature		-55	+150	°C
T_j	junction temperature		-55	+150	°C
V_{isol}	R.M.S isolation voltage from all three terminals to external heatsink	$f = 50\text{ to }60\text{ Hz};$ sinusoidal waveform; R.H. $\leq 65\%$; clean and dust-free; isolated TO-220AB only	-	2500	V

Source-drain diode

I_S	source (diode forward) current (DC)	$T_c = 25\text{ °C}$	-	7	A
-------	-------------------------------------	----------------------	---	---	---

Avalanche ruggedness

$E_{DS(AL)S}$	non-repetitive drain-source avalanche energy	unclamped inductive load, $I_{AS} = 6.5\text{ A}; t_p = 2.3\text{ ms};$ T_j prior to avalanche = $25\text{ °C};$ $V_{DD} \leq 50\text{ V}; R_{GS} = 50\text{ }\Omega;$ $V_{GS} = 10\text{ V}$	-	316	mJ
$E_{DS(AL)R}$	repetitive drain-source avalanche energy	$I_{AR} = 7\text{ A}; t_p = 2.5\text{ }\mu\text{s};$ T_j prior to avalanche = $25\text{ °C};$ $R_{GS} = 50\text{ }\Omega; V_{GS} = 10\text{ V}$	-	13	mJ
$I_{DS(AL)S}$	non-repetitive drain-source avalanche current		-	7	A

[1] For isolated TO-220AB limited only by maximum temperature allowed

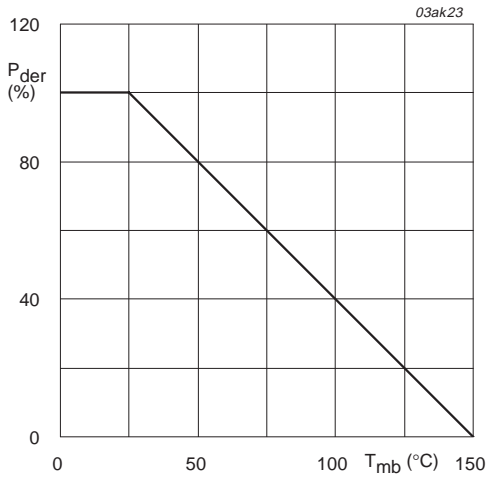

Fig 1. TO-220AB normalized total power dissipation as a function of mounting base temperature.

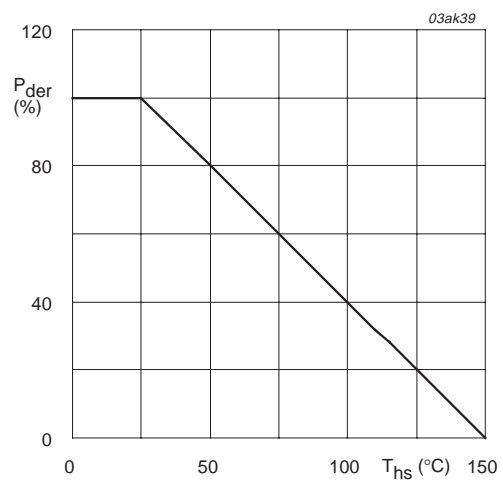

Fig 2. Isolated TO-220AB normalized total power dissipation as a function of heatsink temperature.

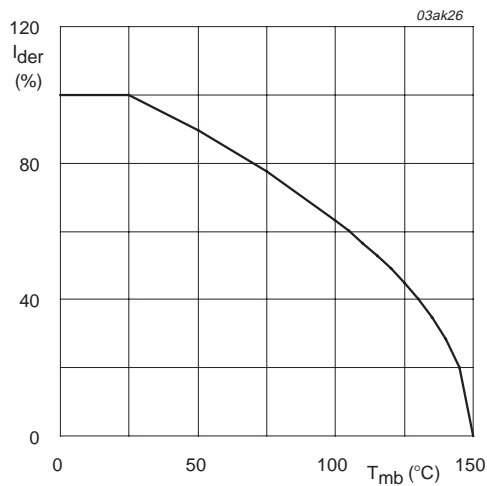

Fig 3. TO-220AB normalized continuous drain current as a function of mounting base temperature.

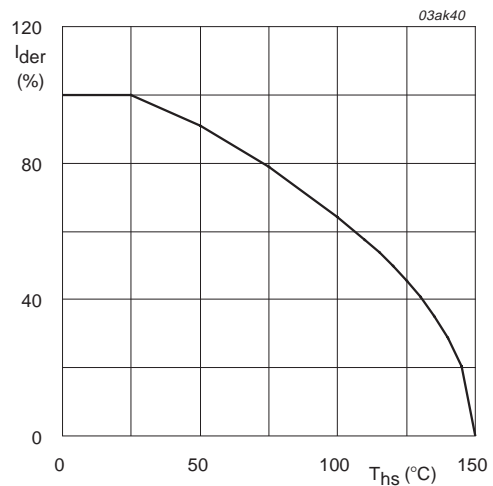
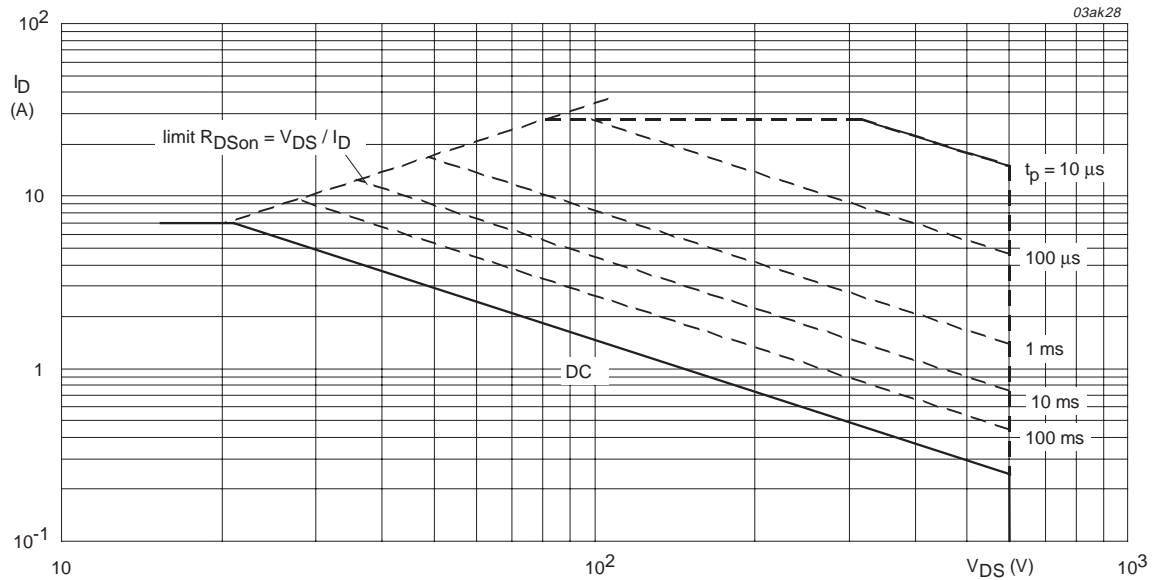
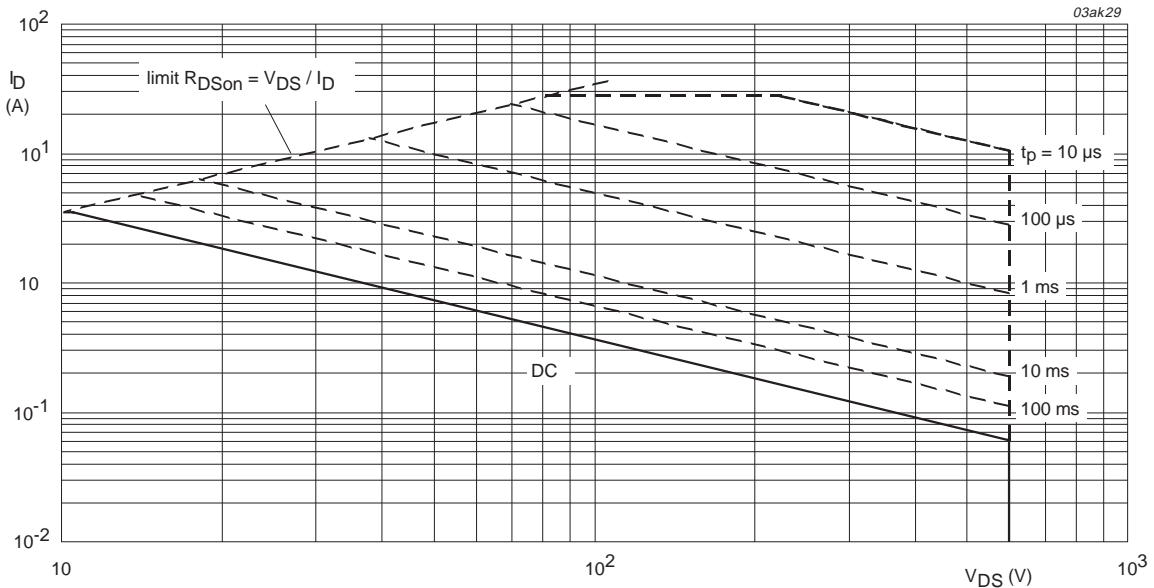

Fig 4. Isolated TO-220AB normalized continuous drain current as a function of heatsink temperature.



$T_{mb} = 25 \text{ }^\circ\text{C}$; I_{DM} is single pulse.

Fig 5. TO-220AB safe operating area; continuous and peak drain currents as a function of drain-source voltage.



$T_{hs} = 25 \text{ }^\circ\text{C}$; I_{DM} is single pulse.

Fig 6. Isolated TO-220AB safe operating area; continuous and peak drain currents as a function of drain-source voltage.

7. Thermal characteristics

Table 4: Thermal characteristics

Symbol	Parameter	Conditions	Min	Typ	Max	Unit
$R_{th(j-mb)}$	thermal resistance from junction to mounting base					
	TO-220AB	Figure 7	-	-	0.85	K/W
$R_{th(j-hs)}$	thermal resistance from junction to heatsink					
	isolated TO-220AB	Figure 8	-	-	3.4	K/W
$R_{th(j-a)}$	thermal resistance from junction to ambient					
	isolated TO-220AB package	vertical in still air	-	55	-	K/W
	TO-220AB package	vertical in still air	-	60	-	K/W

7.1 Transient thermal impedance

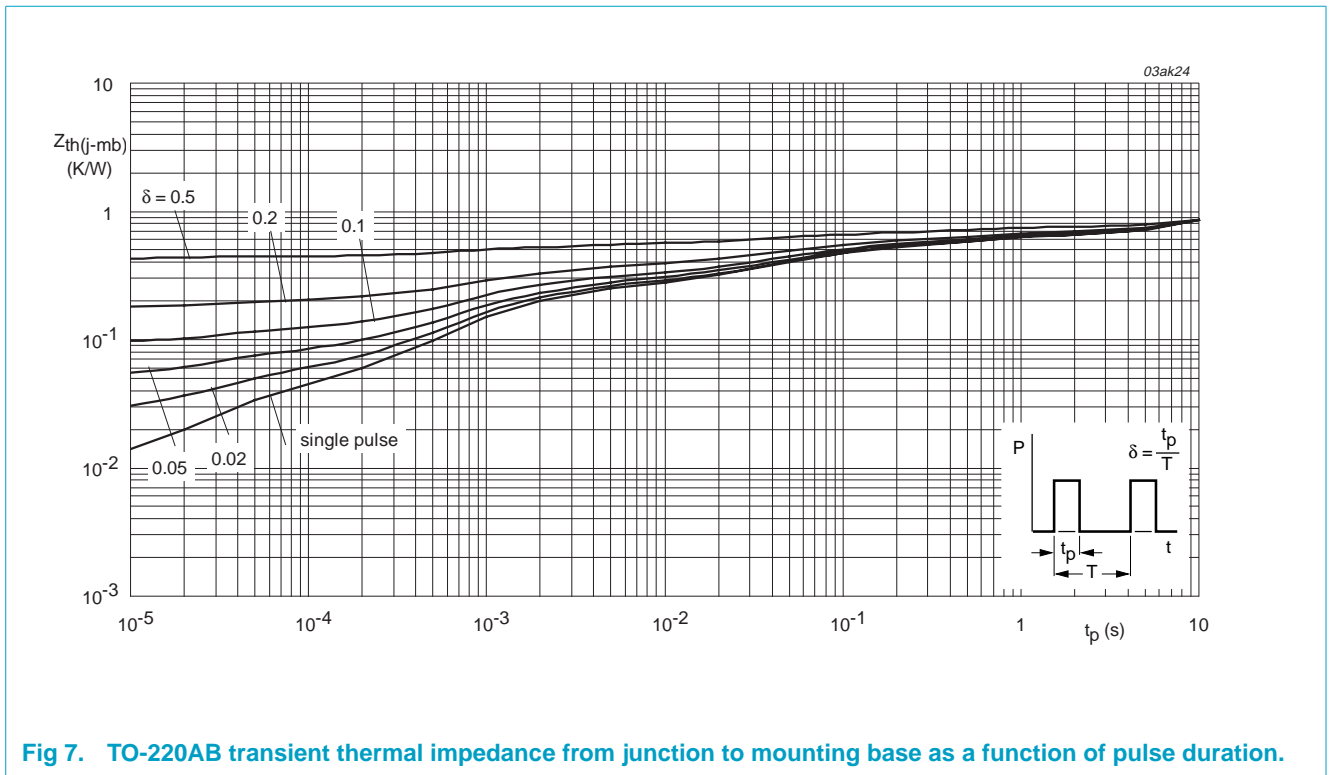

Fig 7. TO-220AB transient thermal impedance from junction to mounting base as a function of pulse duration.

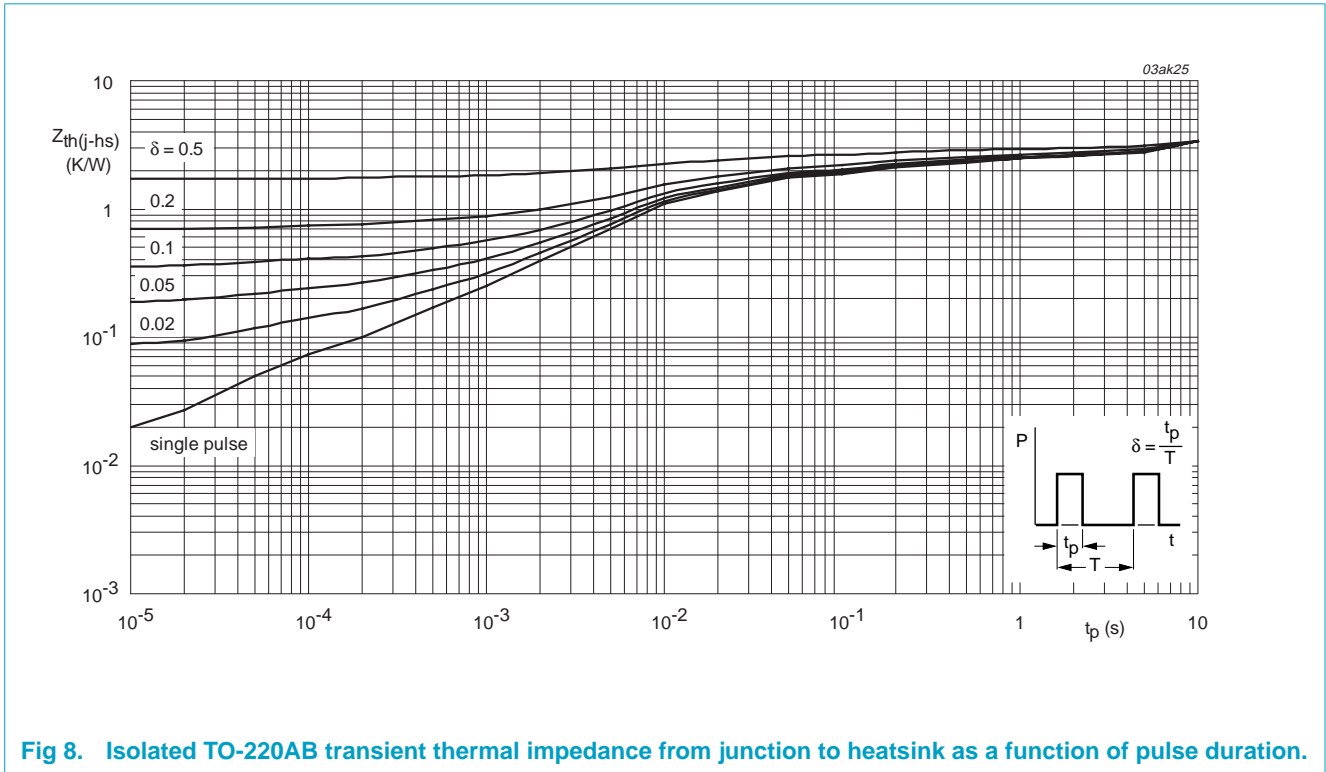
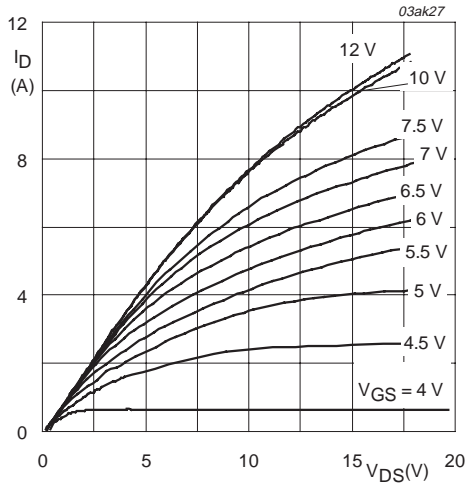

Fig 8. Isolated TO-220AB transient thermal impedance from junction to heatsink as a function of pulse duration.

8. Characteristics

Table 5: Characteristics
 $T_j = 25\text{ }^\circ\text{C}$ unless otherwise specified

Symbol	Parameter	Conditions	Min	Typ	Max	Unit
Static characteristics						
$V_{(BR)DSS}$	drain-source breakdown voltage	$I_D = 250\text{ }\mu\text{A}; V_{GS} = 0\text{ V}$	600	-	-	V
		$T_j = -55\text{ }^\circ\text{C}$	534	-	-	V
$V_{GS(th)}$	gate-source threshold voltage	$I_D = 250\text{ }\mu\text{A}; V_{DS} = V_{GS};$ Figure 13				
		$T_j = 25\text{ }^\circ\text{C}$	2	2.9	4	V
		$T_j = 150\text{ }^\circ\text{C}$	1	-	-	V
		$T_j = -55\text{ }^\circ\text{C}$	-	3.2	4.5	V
I_{DSS}	drain-source leakage current	$V_{GS} = 0\text{ V}; V_{DS} = 600\text{ V}$				
		$T_j = 25\text{ }^\circ\text{C}$	-	0.3	100	μA
		$T_j = 125\text{ }^\circ\text{C}; V_{DS} = 480\text{ V}$	-	150	500	μA
I_{GSS}	gate-source leakage current	$V_{DS} = 0\text{ V}; V_{GS} = \pm 10\text{ V}$	-	2	200	nA
$R_{DS(on)}$	drain-source on-state resistance	$V_{GS} = 10\text{ V}; I_D = 3.5\text{ A};$ Figure 11 and 12				
		$T_j = 25\text{ }^\circ\text{C}$	-	0.94	1.2	Ω
		$T_j = 150\text{ }^\circ\text{C}$	-	2.4	2.9	Ω
C_{isol}	Capacitance from pin 2 to external heatsink	$f = 1\text{ MHz};$ isolated TO-220AB only	-	10	-	pF
Dynamic characteristics						
$Q_{g(tot)}$	total gate charge	$I_D = 7\text{ A}; V_{DD} = 480\text{ V}; V_{GS} = 10\text{ V};$ Figure 17	-	27	-	nC
Q_{gs}	gate-source charge		-	3.6	-	nC
Q_{gd}	gate-drain (Miller) charge		-	10	-	nC
C_{iss}	input capacitance	$V_{GS} = 0\text{ V}; V_{DS} = 25\text{ V}; f = 1\text{ MHz};$ Figure 15	-	1130	-	pF
C_{oss}	output capacitance		-	105	-	pF
C_{rss}	reverse transfer capacitance		-	24	-	pF
$t_{d(on)}$	turn-on delay time	$V_{DD} = 300\text{ V}; R_D = 39\text{ }\Omega; R_G = 9.1\text{ }\Omega$	-	17	-	ns
t_r	rise time		-	20	-	ns
$t_{d(off)}$	turn-off delay time		-	40	-	ns
t_f	fall time		-	20	-	ns
Source-drain diode						
V_{SD}	source-drain (diode forward) voltage	$I_S = 7\text{ A}; V_{GS} = 0\text{ V};$ Figure 16	-	0.9	1.2	V
t_{rr}	reverse recovery time	$I_S = 7\text{ A}; di_S/dt = -100\text{ A}/\mu\text{s}; V_{GS} = 0\text{ V}$	-	530	-	ns
Q_r	recovered charge		-	6.7	-	μC



$T_j = 25\text{ }^\circ\text{C}$

Fig 9. Output characteristics: drain current as a function of drain-source voltage; typical values.

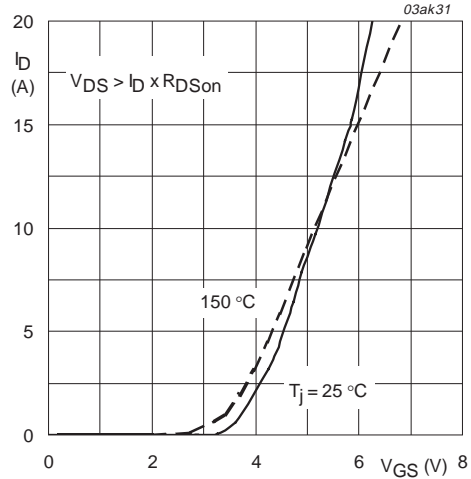

$T_j = 25\text{ }^\circ\text{C}$ and $150\text{ }^\circ\text{C}$; $V_{DS} > I_D \times R_{DSon}$

Fig 10. Transfer characteristics: drain current as a function of gate-source voltage; typical values.

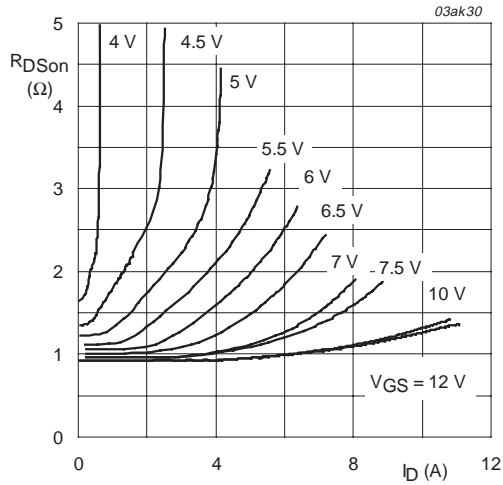

$T_j = 25\text{ }^\circ\text{C}$

Fig 11. Drain-source on-state resistance as a function of drain current; typical values.

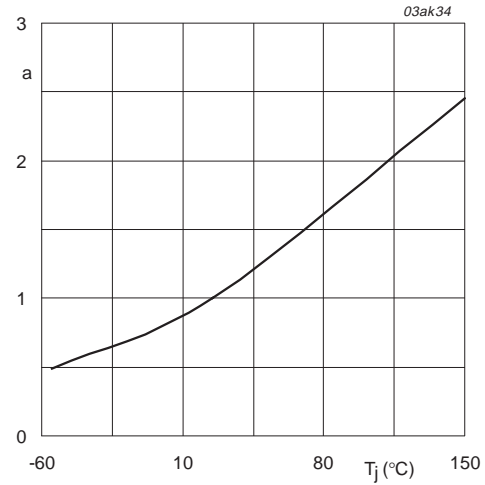

$$a = \frac{R_{DSon}}{R_{DSon(25^\circ\text{C})}}$$

Fig 12. Normalized drain-source on-state resistance factor as a function of junction temperature.

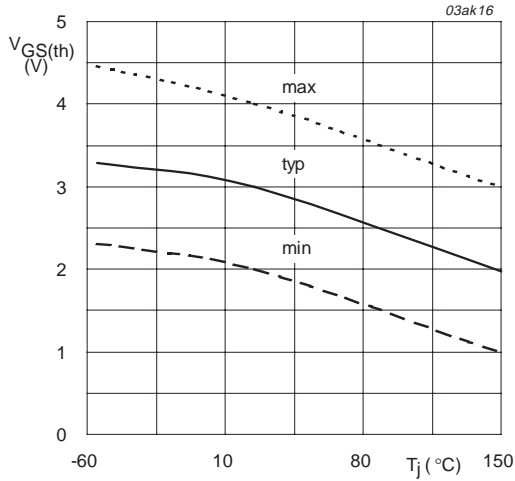

$I_D = 1 \text{ mA}; V_{DS} = V_{GS}$

Fig 13. Gate-source threshold voltage as a function of junction temperature.

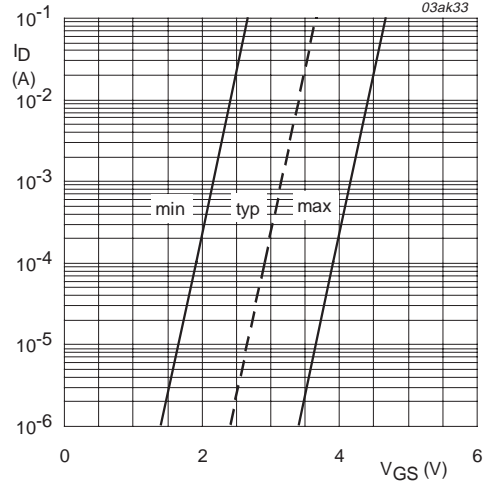

$T_j = 25 \text{ }^{\circ}C; V_{DS} = 5 \text{ V}$

Fig 14. Sub-threshold drain current as a function of gate-source voltage.

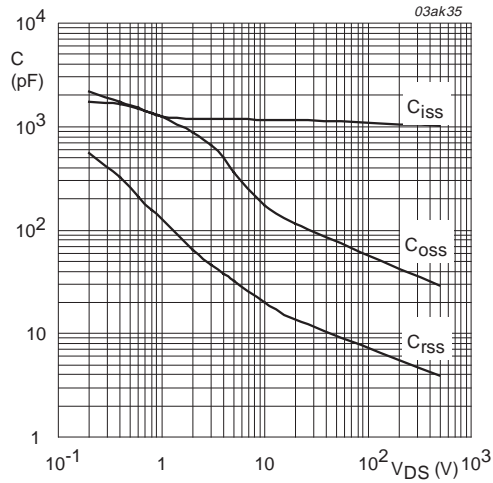

$V_{GS} = 0 \text{ V}; f = 1 \text{ MHz}$

Fig 15. Input, output and reverse transfer capacitances as a function of drain-source voltage; typical values.

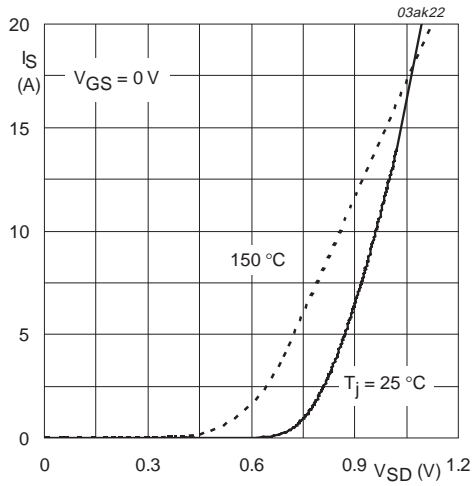

$T_j = 25\text{ °C}$ and 150 °C ; $V_{GS} = 0\text{ V}$

Fig 16. Source (diode forward) current as a function of source-drain (diode forward) voltage; typical values.

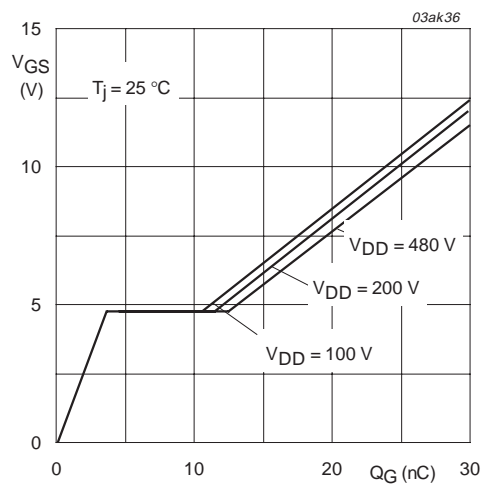

$I_D = 7\text{ A}$; $V_{DD} = 100\text{ V}$; 200 V ; 480 V

Fig 17. Gate-source voltage as a function of gate charge; typical values.

9. Package outline

Plastic single-ended package; heatsink mounted; 1 mounting hole; 3-lead TO-220AB

SOT78

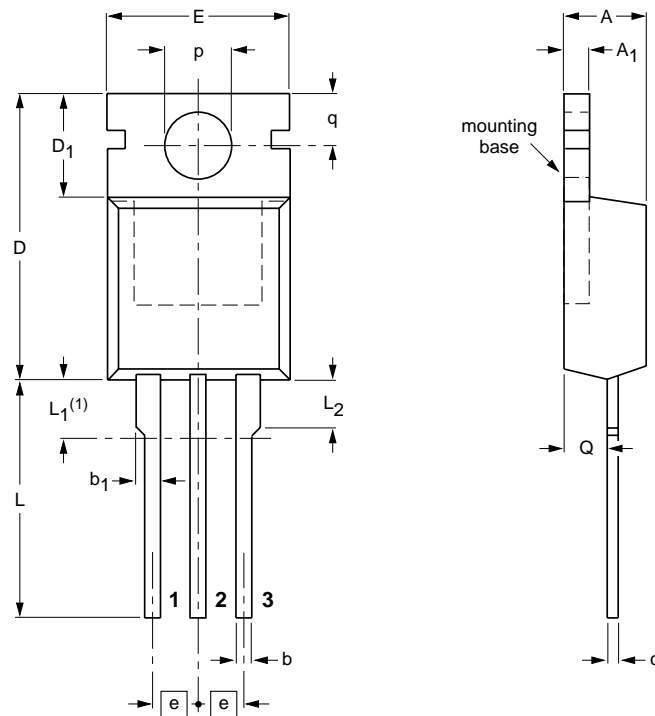

DIMENSIONS (mm are the original dimensions)

UNIT	A	A ₁	b	b ₁	c	D	D ₁	E	e	L	L ₁ (¹)	L ₂ max.	p	q	Q
mm	4.5 4.1	1.39 1.27	0.9 0.7	1.3 1.0	0.7 0.4	15.8 15.2	6.4 5.9	10.3 9.7	2.54	15.0 13.5	3.30 2.79	3.0	3.8 3.6	3.0 2.7	2.6 2.2

Note

1. Terminals in this zone are not tinned.

OUTLINE VERSION	REFERENCES			EUROPEAN PROJECTION	ISSUE DATE
	IEC	JEDEC	EIAJ		
SOT78		3-lead TO-220AB	SC-46		00-09-07 01-02-16

Fig 18. TO-220AB (SOT78)

Plastic single-ended package; isolated heatsink mounted;
1 mounting hole; 3 lead TO-220 'full pack'

SOT186A

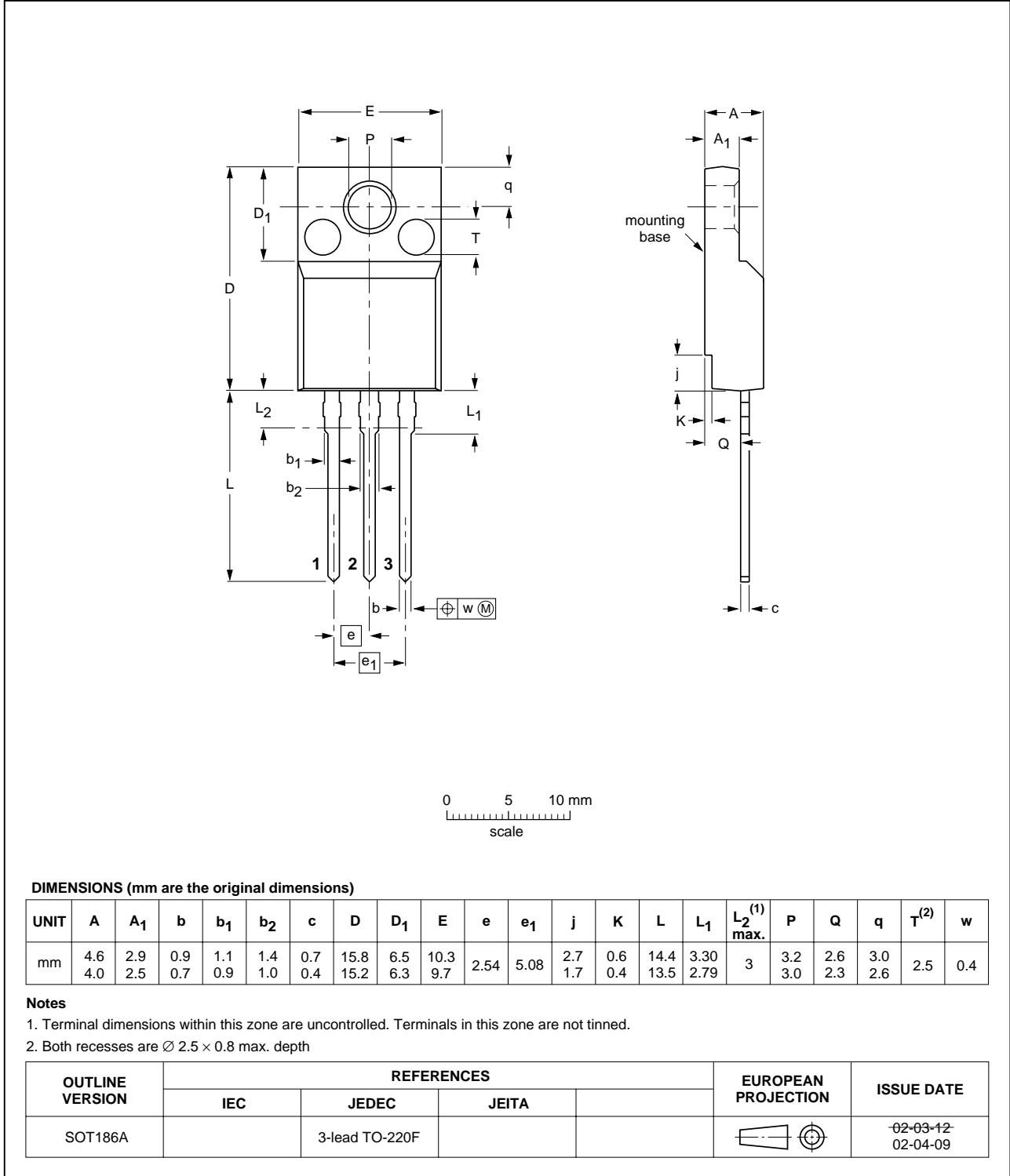

Fig 19. isolated TO-220AB

10. Revision history

Table 6: Revision history

Rev	Date	CPCN	Description
01	20020820		Product specification; initial version.

11. Data sheet status

Data sheet status ^[1]	Product status ^[2]	Definition
Objective data	Development	This data sheet contains data from the objective specification for product development. Philips Semiconductors reserves the right to change the specification in any manner without notice.
Preliminary data	Qualification	This data sheet contains data from the preliminary specification. Supplementary data will be published at a later date. Philips Semiconductors reserves the right to change the specification without notice, in order to improve the design and supply the best possible product.
Product data	Production	This data sheet contains data from the product specification. Philips Semiconductors reserves the right to make changes at any time in order to improve the design, manufacturing and supply. Changes will be communicated according to the Customer Product/Process Change Notification (CPCN) procedure SNW-SQ-650A.

[1] Please consult the most recently issued data sheet before initiating or completing a design.

[2] The product status of the device(s) described in this data sheet may have changed since this data sheet was published. The latest information is available on the Internet at URL <http://www.semiconductors.philips.com>.

12. Definitions

Short-form specification — The data in a short-form specification is extracted from a full data sheet with the same type number and title. For detailed information see the relevant data sheet or data handbook.

Limiting values definition — Limiting values given are in accordance with the Absolute Maximum Rating System (IEC 60134). Stress above one or more of the limiting values may cause permanent damage to the device. These are stress ratings only and operation of the device at these or at any other conditions above those given in the Characteristics sections of the specification is not implied. Exposure to limiting values for extended periods may affect device reliability.

Application information — Applications that are described herein for any of these products are for illustrative purposes only. Philips Semiconductors make no representation or warranty that such applications will be suitable for the specified use without further testing or modification.

13. Disclaimers

Life support — These products are not designed for use in life support appliances, devices, or systems where malfunction of these products can reasonably be expected to result in personal injury. Philips Semiconductors customers using or selling these products for use in such applications do so at their own risk and agree to fully indemnify Philips Semiconductors for any damages resulting from such application.

Right to make changes — Philips Semiconductors reserves the right to make changes, without notice, in the products, including circuits, standard cells, and/or software, described or contained herein in order to improve design and/or performance. Philips Semiconductors assumes no responsibility or liability for the use of any of these products, conveys no licence or title under any patent, copyright, or mask work right to these products, and makes no representations or warranties that these products are free from patent, copyright, or mask work right infringement, unless otherwise specified.

Contact information

For additional information, please visit <http://www.semiconductors.philips.com>.

For sales office addresses, send e-mail to: sales.addresses@www.semiconductors.philips.com.

Fax: +31 40 27 24825

Contents

1	Description	1
2	Features	1
3	Applications	1
4	Pinning information	1
5	Quick reference data	2
6	Limiting values	2
7	Thermal characteristics	5
7.1	Transient thermal impedance	5
8	Characteristics	7
9	Package outline	11
10	Revision history	13
11	Data sheet status	14
12	Definitions	14
13	Disclaimers	14



PHILIPS

Let's make things better.