

Transformers

For Power Supply

Pin Terminal

PLT, PLC Series

FEATURES

- TDK has optimized the characteristics of ferrite cores for high frequency operation and has designed multilayer printed coils with optimized pattern designs. This has resulted in low insertion loss and low leakage inductance. The PLT and PLC series attains high efficiency as well as light weight and small size.
- While only 5mm tall, this miniaturized planar transformer/planar choke coil combination also has a greatly reduced footprint.
- Shielding of the printed coil by the core has greatly reduced noise.
- While maintaining reliability of the electrical connection between each layer of the printed coil and the L-shaped header terminal, the structure of these PLT/PLC series products also allows easy checking of soldered connections after board mounting.

APPLICATIONS

Low-profile DC to DC converters for exchange switchboard power supplies, low-profile DC to DC converters for various types of power supplies(engine control modules, HID lamps).

ELECTRICAL CHARACTERISTICS(Typical)

PLANAR TRANSFORMERS

Part No.	Input voltage	Output voltage	Output current	Rated output	Primary inductance (μ H)	Primary leakage inductance (μ H)	DC resistance (m Ω)	
	E _{dc} (V)	E _{dc} (V)	I _{dc} (A)	power (W)			Primary	Secondary
PLT1414EIR-01	48	5	4	20	200	0.2	150	6
PLT1818EIR-01	48	5	6	30	90	0.1	35	1.9
PLT2322EIR-01	48	5	10	50	70	0.07	18	1.6
PLT2725EIR-01	48	5	20	100*	60	0.08	15	1.3

* Only PLT2725HS-001 was evaluated while using an attached aluminum heat sink.

PLANAR CHOKE COILS

Part No.	DC superposition current (A)	Inductance (μ H)	DC resistance (m Ω)
PLC1414EIR-22-01	2	22	19
PLC1414RIR-15-01	3	15	19
PLC1414EIR-11-01	4	11	19
PLC1818EIR-15-01	4	15	16
PLC1818EIR-12-01	5	12	16
PLC1818EIR-10-01	6	10	16
PLC2322EIR-9R5-01	8	9.5	15
PLC2322EIR-7R5-01	10	7.5	15

SPECIFICATIONS

Withstand voltage[AC.500V, 1min]	No abnormalities
Insulation resistance[DC.500V applied]	100M Ω min.
Winding thermal classification	105°C

DESIGN REQUIREMENTS

Circuit type	Forward circuit
Operating frequency	500kHz
Board	Aluminum
Cooling method	Natural air cooling

TYPICAL CIRCUIT

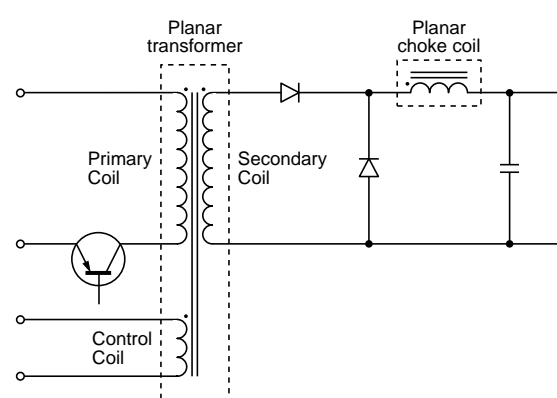

Transformers

For Power Supply

Pin Terminal

PLT, PLC Series

SHAPES AND DIMENSIONS/RECOMMENDED PC BOARD PATTERNS

PLT1414, PLC1414 SERIES

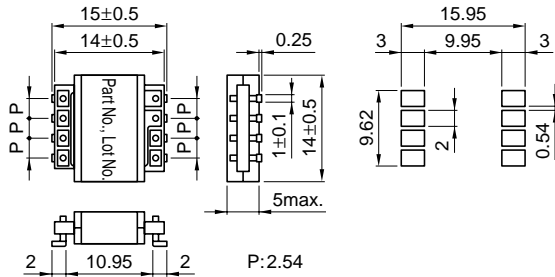

PLT1818, PLC1818 SERIES

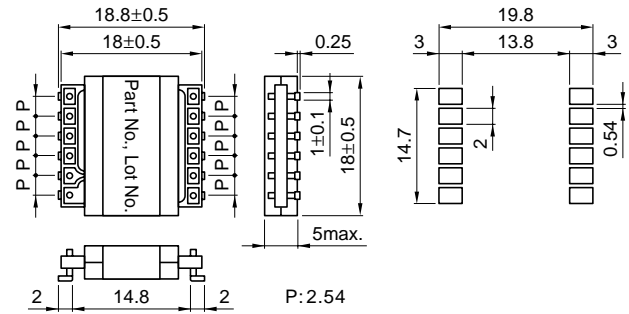

PLT2322, PLC2322 SERIES

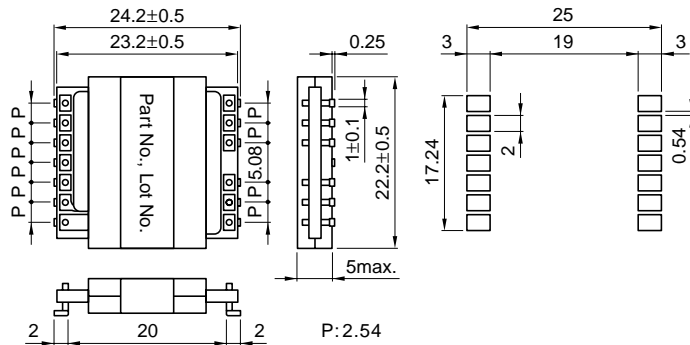

PLT2725 SERIES

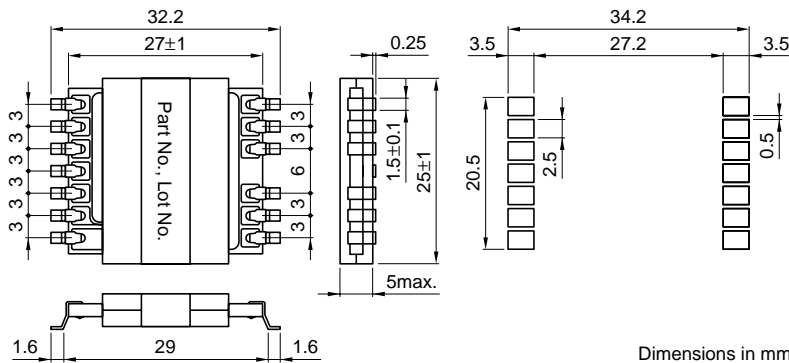

Dimensions in mm

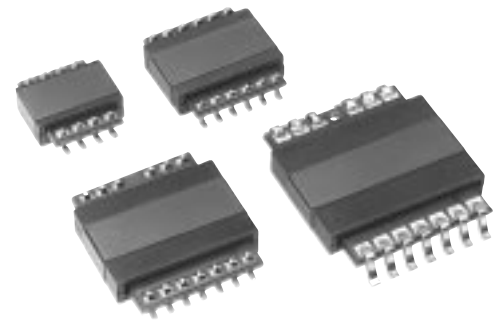

RECOMMENDED SOLDERING CONDITIONS

REFLOW SOLDERINGS

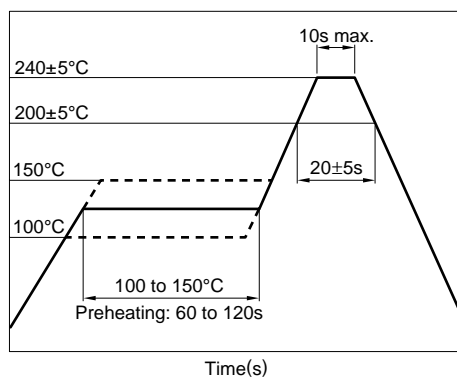

Transformers

For Power Supply Pin Terminal

PLT, PLC Series

PRECAUTIONS

Care should be taken since product operation can become impaired under the following circumstances.

- The product should not be used after undergoing the mechanical stress of being dropped, etc.
- There are instances when performance can become impaired due to core cracking, etc., even though visual appearance of the product is unaffected.
- Contamination, dust, fog, water droplets, and direct sunlight should be avoided during storage. Inappropriate storage conditions can result in malfunctioning of the product.
- Operation and storage environments should be avoided that could cause corrosion(chlorine gas, oxygen gas, alkaline, etc. environments).
- Excessive force should not be applied to the product by metal tools, etc. during mounting. Furthermore, the product should be kept bare since encasing the product in resin, etc. can possibly result in degradation of the printed coil isolation characteristics and can greatly alter inductance(lower L).

The product should be used under appropriate condition.

- TDK recommends applications utilizing the suggested board pattern. If the product is used under other conditions, the customer should confirm that no problems result under manufacturing conditions.
- Required reflow conditions greatly depend upon board mounting conditions. Therefore reflow conditions must be confirmed by testing.
- In principle, cleaning should be avoided after mounting. If cleaning is carried out, cleaning conditions should be confirmed by reliability, etc. testing.

Temperature rise, isolation, and abnormal conditions.

- The temperature rise of this product is greatly affecting by board mounting conditions. Therefore temperature rise must be confirmed by testing.
- Caution should be used when carrying out insulation resistance testing above the rated voltage since the performance of insulation can degrade under such conditions.
- Since this product does not have a built-in protective function to counter abnormal conditions such as excess load, short circuits, open circuits, etc., testing must be carried out to confirm the absence of safety problems.