

## PM45100K

### Silicon N-Channel Power MOS FET Module for High-Speed Power Switching

#### Features

- Equipped with Power MOS FET
- Low on-resistance
- High speed switching
- Low drive current
- Wide area of safe operation
- Inherent parallel diode between source and drain
- Isolated base from Terminal
- Suitable for motor driver, switching regulator and etc.

#### Absolute Maximum Ratings (Ta = 25°C) (Per FET chip)

Item	Symbol	Rating	Unit
Drain source voltage	$V_{(BR)DSS}$	450	V
Gate source voltage	$V_{(BR)GSS}$	±30	V
Drain current	$I_D$	100	A
Drain peak current	$I_{D(peak)}$	240	A
Body-drain diode reverse drain current	$I_{DR}$	100	A
Body-drain diode reverse peak current	$I_{DR(peak)}$	240	A
Channel dissipation	$P_{ch}^{*1}$	400	W
Channel temperature	$T_{ch}$	150	°C
Storage temperature	$T_{stg}$	-45 to +125	°C
Insulation dielectric	$V_{iso}^{*2}$	2000	Vrms

Notes: 1. Value at Ta = 25 °C  
2. Base to terminals AC minute

#### Pin Arrangement

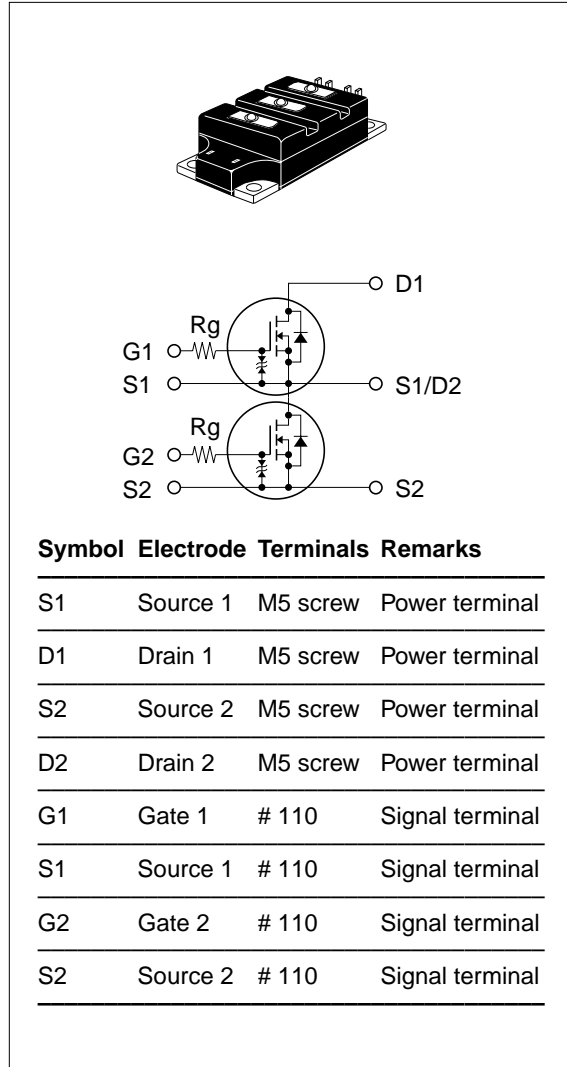

## Electrical Characteristics (Ta = 25°C) (Per FET chip)

Item	Symbol	Min	Typ	Max	Unit	Test Condition
Drain-source breakdown voltage	$V_{(BR)DSS}$	450	—	—	V	$I_D = 10 \text{ mA}, V_{GS} = 0 \text{ V}$
Gate-source leak current	$I_{GSS}$	—	—	±10	μA	$V_{GS} = \pm 25 \text{ V}, V_{DS} = 0 \text{ V}$
Gate-source breakdown voltage	$V_{(BR)GSS}$	±30	—	—	V	$I_G = \pm 100 \text{ μA}, V_{DS} = 0 \text{ V}$
Drain leak current	$I_{DSS}$	—	—	1	mA	$V_{DS} = 360 \text{ V}, V_{GS} = 0 \text{ V}$
Gate-source threshold voltage	$V_{GS(th)}$	2.0	—	3.0	V	$I_D = 1 \text{ mA}, V_{DS} = 10 \text{ V}$
Drain-source saturation voltage	$V_{DS(on)}$	—	4.0	5.0	V	$I_D = 50 \text{ A}, V_{GS} = 10 \text{ V}^{*1}$
Static Drain-source on state resistance	$R_{DS(on)}$	—	0.08	0.10	Ω	$I_D = 50 \text{ A}, V_{GS} = 10 \text{ V}^{*1}$
Forward transfer admittance	$ y_{fs} $	—	55	—	S	$I_D = 50 \text{ A}, V_{DS} = 10 \text{ V}^{*1}$
Input capacitance	$C_{iss}$	—	14600	—	pF	$V_{DS} = 10 \text{ V}, V_{GS} = 0 \text{ V}$ $f = 1 \text{ MHz}$
Output capacitance	$C_{oss}$	—	3500	—		
Reverse transfer capacitance	$C_{rss}$	—	650	—		
Turn-on delay time	$t_{d(on)}$	—	200	—	ns	$I_D = 50 \text{ A}, V_{GS} = 10 \text{ V}$ $R_g = 50 \text{ Ω}$ $R_L = 0.6 \text{ Ω}$
Rise time	$t_r$	—	690	—		
Turn-off delay time	$t_{d(off)}$	—	760	—		
Fall time	$t_f$	—	260	—		
Body-drain diode forward voltage	$V_{DF}$	—	1.6	—	V	$I_F = 100 \text{ A}, V_{GS} = 0 \text{ V}$
Body-drain diode reverse recovery time	$t_{rr}$	—	140	—	ns	$I_F = 100 \text{ A}, V_{GS} = 0 \text{ V}$ $di/dt = 100 \text{ A/μs}$

Note: 1 Pulse Test

## Mechanical characteristics

Item	Symbol	Condition	Rating	Unit
Fixing strength	—	Mounting into main-terminal with M4 screw	1.45 to 1.95	N-m
	—	Mounting into heat sink with M5 screw	1.95 to 2.9	N-m
Weight	—	Typical value	380	g

