

PNA4611M Series (PNA4611M/4612M/4613M/4614M/4620M)

Bipolar Integrated Circuit with Photodetection Function

For infrared remote control systems

■ Features

- High sensitivity (extension distance is 11 m or more)
- External parts not required
- Resin to cutoff visible light is used
- Supports various metal holders with improved electromagnetic noise resistance

■ Absolute Maximum Ratings (Ta = 25°C)

Parameter	Symbol	Ratings	Unit
Power supply voltage	V _{CC}	-0.5 to +7	V
Power dissipation	P _D	200	mW
Operating ambient temperature	T _{opr}	-20 to +75	°C
Storage temperature	T _{stg}	-40 to +100	°C

■ Main Characteristics (Ta = 25°C V_{CC} = 5V)

Parameter	Symbol	Conditions	min	typ	max	Unit
Operating supply voltage	V _{CC}		4.7	5.0	5.3	V
Current consumption	I _{CC}	Note 3	1.8	2.4	3.0	mA
Maximum reception distance	L _{max}	Note 1	11	16		m
Low-level output voltage	V _{OL}	Note 2		0.35	0.5	V
High-level output voltage	V _{OH}	Note 3	4.8	5.0	V _{CC}	V
Low-level pulse width	T _{WL}	Note 1	200	400	600	μs
High-level pulse width	T _{WH}	Note 1	200	400	600	μs
Carrier frequency	PNA4611M	f ₀		36.7		kHz
	PNA4612M			38.0		
	PNA4613M			40.0		
	PNA4614M			56.9		
	PNA4620M			33.3		

Note 1) Fig.1 burst wave, L = L_{max}, 16 pulses

Note 2) Fig.2 continuous wave, L ≤ L_{max}

Note 3) Light shut off condition

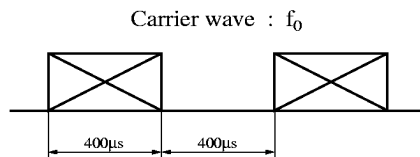

Fig.1

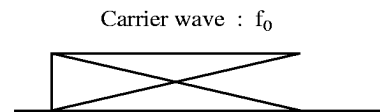
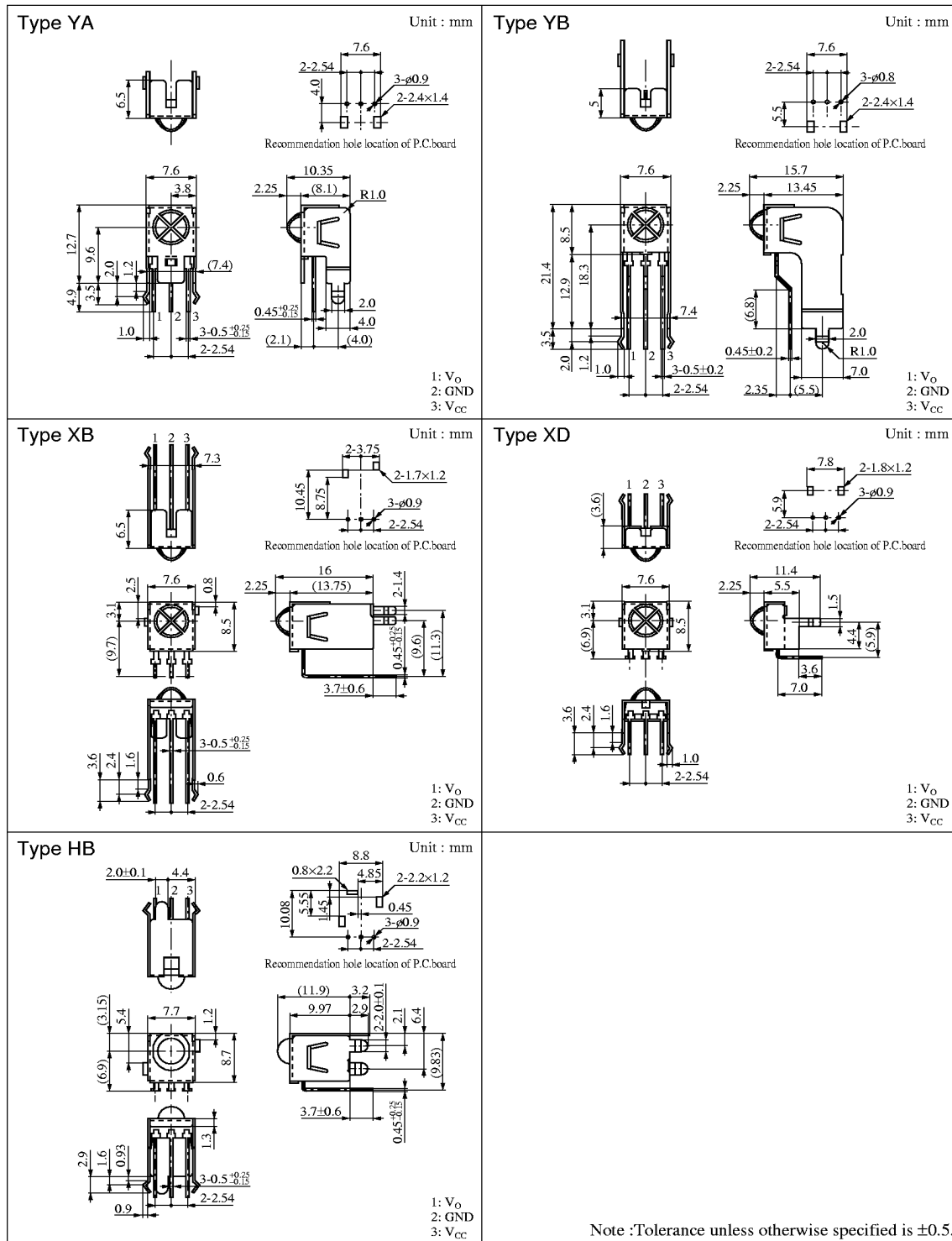
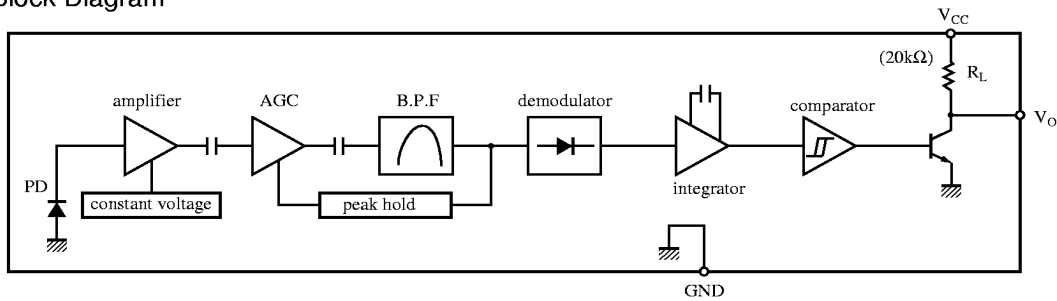

Fig.2



Note :Tolerance unless otherwise specified is ±0.5.

■ Block Diagram



■ Panasonic Transmitter Specifications

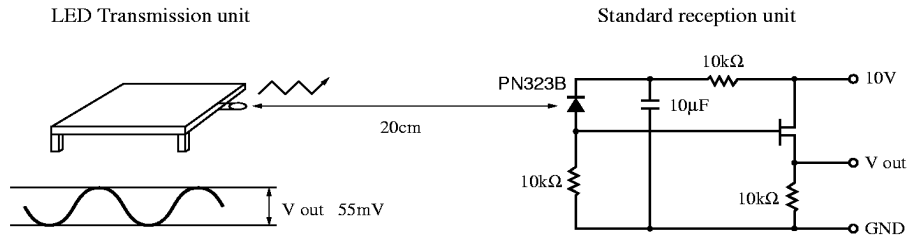

- The light output of the LED transmission unit is adjusted so that the transmission output (V_{out}) of the standard reception unit will be 55 mV when the transmission waveform (duty = 50%) is output from the LED transmission unit. However, with PN323B products, infrared sensitivity (SIR) is $0.53 \mu\text{A}$ when emission illuminance (H) is $12.45 \mu\text{W}/\text{cm}^2$.
- The maximum reception distance under these specifications is an assurance that the product's T_{WH} and T_{WL} values will be within the tolerance ranges when 16 consecutive pulses are transmitted by the above transmission unit at an optical output equivalent to the maximum reception distance. (The maximum reception distance is measured in the dark without disturbance noise.)

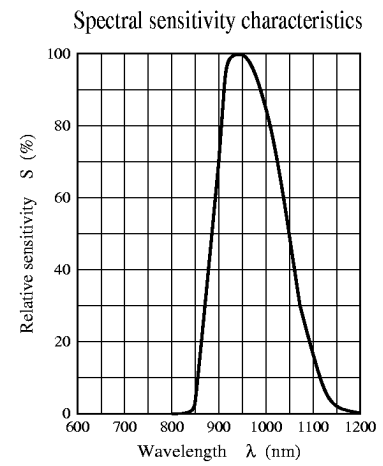
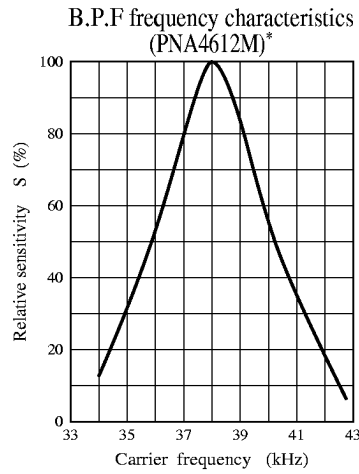
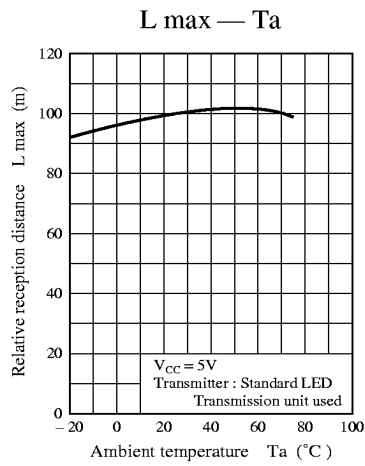

* The peaks for PNA4611M, PNA4613M, PNA4614M, and PNA4620M are all at f_0 .

