

## HIGH COLLECTOR TO EMITTER VOLTAGE 4-PIN ULTRA SMALL FLAT-LEAD PHOTOCOUPLER

-NEPOC Series-

### DESCRIPTION

The PS2932-1, PS2933-1 are optically coupled isolator containing a GaAs light emitting diode and an NPN silicon phototransistor in one package for high density mounting applications.

An ultra small flat-lead package has been provided which realizes a reduction in mounting area of about 30% compared with the PS28xx series.

### FEATURES

- ★ • Small and thin package (4.6 (L) × 2.5 (W) × 2.1 (H) mm)
- Isolation distance (0.4 mm MIN.)
- High collector to emitter voltage ( $V_{CEO} = 300\text{ V}$ : PS2932-1)  
( $V_{CEO} = 350\text{ V}$ : PS2933-1)
- High isolation voltage ( $BV = 2\ 500\text{ Vr.m.s.}$ )
- Ordering number of taping product: PS2932-1-F3, F4: 3 500 pcs/reel  
PS2933-1-F3, F4: 3 500 pcs/reel

### APPLICATIONS

- Hybrid IC
- Telephone, Exchange equipment, FAX

The information in this document is subject to change without notice. Before using this document, please confirm that this is the latest version.  
Not all devices/types available in every country. Please check with local NEC Compound Semiconductor Devices representative for availability and additional information.

★ PACKAGE DIMENSIONS (UNIT: mm)

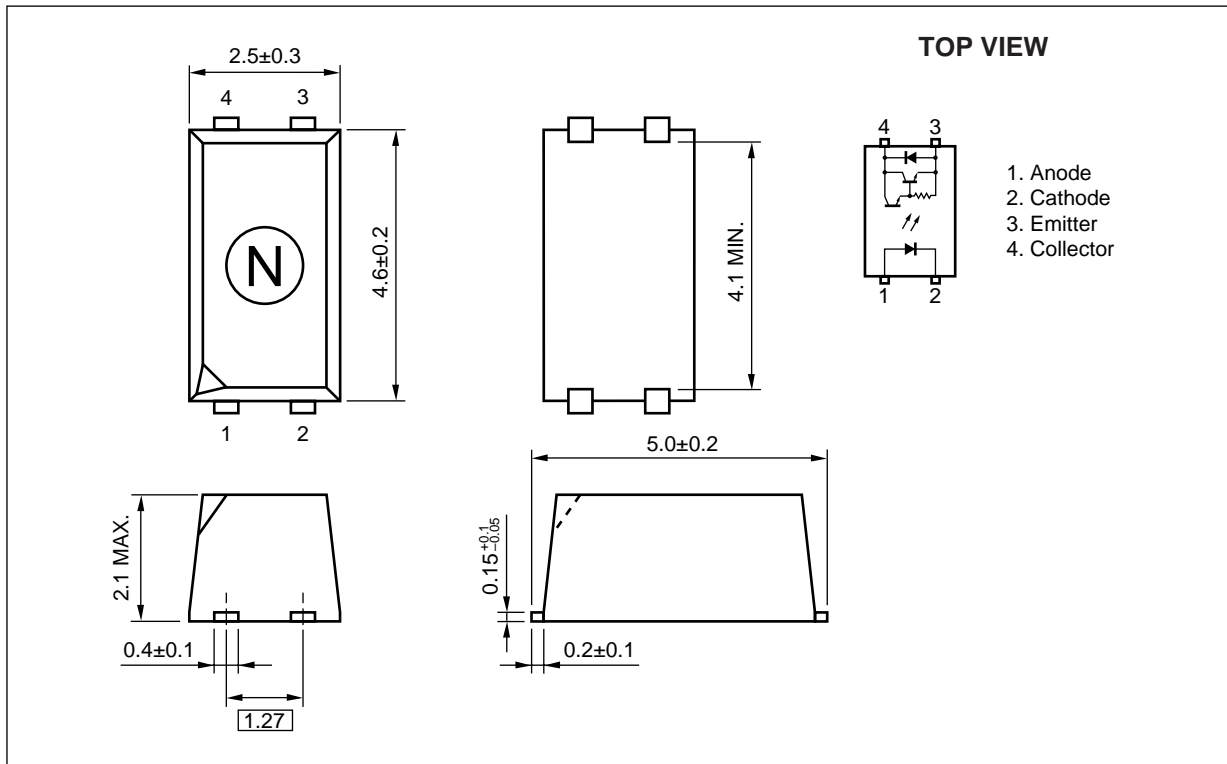

MARKING (example: PS2932-1)

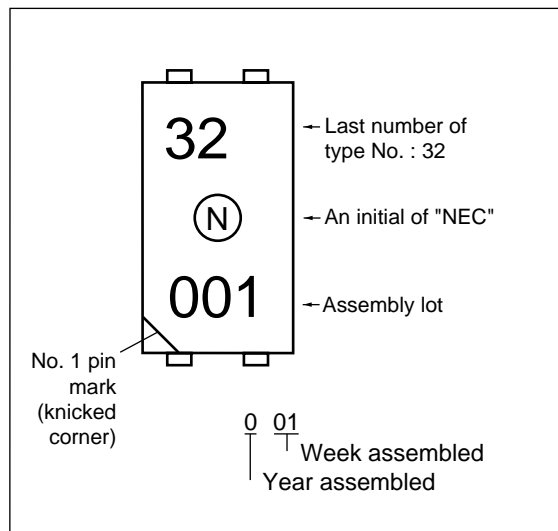

PHOTOCOUPLER CONSTRUCTION

Parameter	Unit (MIN.)
★ Air Distance	4 mm
★ Creepage Distance	4 mm
Isolation Distance	0.4 mm

★ ORDERING INFORMATION

Part Number	Package	Packing Style	Application Part Number <sup>*1</sup>
PS2932-1-F3	4-pin ultra small flat-lead	Embossed Tape 3 500 pcs/reel	PS2932-1
PS2932-1-F4			
PS2933-1-F3			PS2933-1
PS2933-1-F4			

\*1 For the application of the Safety Standard, following part number should be used.

**ABSOLUTE MAXIMUM RATINGS (T<sub>A</sub> = 25°C, unless otherwise specified)**

Parameter	Symbol	Ratings		Unit	
		PS2932-1	PS2933-1		
Diode	Forward Current	I <sub>F</sub>	50		mA
	Forward Current Derating	ΔI <sub>F</sub> /°C	0.5		mA/°C
	Peak Forward Current <sup>*1</sup>	I <sub>FP</sub>	0.5		A
	Power Dissipation	P <sub>D</sub>	60		mW
	Reverse Voltage	V <sub>R</sub>	6		V
Transistor	Collector to Emitter Voltage	V <sub>CEO</sub>	300	350	V
	Emitter to Collector Voltage	V <sub>ECO</sub>	0.3		V
	Collector Current	I <sub>C</sub>	60		mA
	Power Dissipation Derating	ΔP <sub>C</sub> /°C	1.2		mW/°C
	Power Dissipation	P <sub>C</sub>	120		mW
Isolation Voltage <sup>*2</sup>	BV	2 500		Vr.m.s.	
Total Power Dissipation	P <sub>T</sub>	160		mW	
Operating Ambient Temperature	T <sub>A</sub>	-55 to +100		°C	
Storage Temperature	T <sub>stg</sub>	-55 to +150		°C	

\*1 PW = 100 μs, Duty Cycle = 1%

\*2 AC voltage for 1 minute at T<sub>A</sub> = 25°C, RH = 60% between input and output

★ ELECTRICAL CHARACTERISTICS (T<sub>A</sub> = 25°C)

Parameter		Symbol	Conditions	MIN.	TYP.	MAX.	Unit
Diode	Forward Voltage	V <sub>F</sub>	I <sub>F</sub> = 1 mA	0.9	1.1	1.3	V
	Reverse Current	I <sub>R</sub>	V <sub>R</sub> = 5 V			5	μA
	Terminal Capacitance	C <sub>t</sub>	V = 0 V, f = 1 MHz		15		pF
Transistor	Collector to Emitter Current	I <sub>CEO</sub>	V <sub>CE</sub> = 300 V (350 V) <sup>*1</sup>			400	nA
Coupled	Current Transfer Ratio (I <sub>c</sub> /I <sub>F</sub> )	CTR	I <sub>F</sub> = 1 mA, V <sub>CE</sub> = 2 V	400	2 000	4 500	%
	Collector Saturation Voltage	V <sub>CE(sat)</sub>	I <sub>F</sub> = 1 mA, I <sub>c</sub> = 2 mA		0.8	1	V
	Isolation Resistance	R <sub>I-O</sub>	V <sub>I-O</sub> = 1 kV <sub>DC</sub>	10 <sup>11</sup>			Ω
	Isolation Capacitance	C <sub>I-O</sub>	V = 0 V, f = 1 MHz		0.4		pF
	Rise Time <sup>*2</sup>	t <sub>r</sub>	V <sub>CC</sub> = 5 V, I <sub>c</sub> = 10 mA, R <sub>L</sub> = 100 Ω		20		μs
	Fall Time <sup>*2</sup>	t <sub>f</sub>			5		

\*1 I<sub>CEO</sub> condition; PS2932-1: V<sub>CE</sub> = 300 V, PS2933-1: V<sub>CE</sub> = 350 V

\*2 Test circuit for switching time

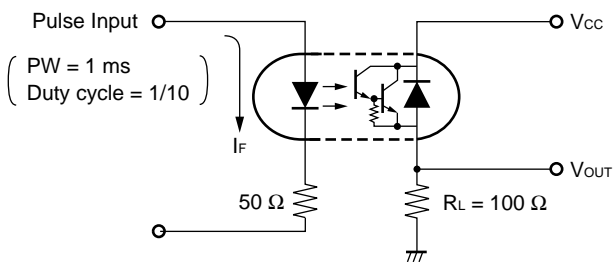

★ CAUTIONS REGARDING NOISE

Be aware that when voltage is applied suddenly between the photocoupler's input and output or between corrector-emitters at startup, the output side may enter the on state, even if the voltage is within the absolute maximum ratings.

★ TYPICAL CHARACTERISTICS ( $T_A = 25^\circ\text{C}$ , unless otherwise specified)

MAXIMUM FORWARD CURRENT vs. AMBIENT TEMPERATURE

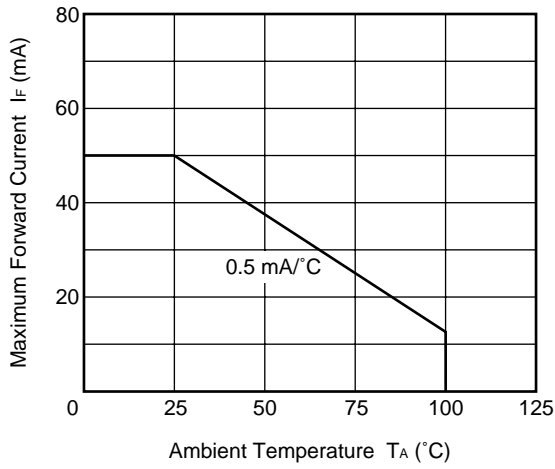

TRANSISTOR POWER DISSIPATION vs. AMBIENT TEMPERATURE

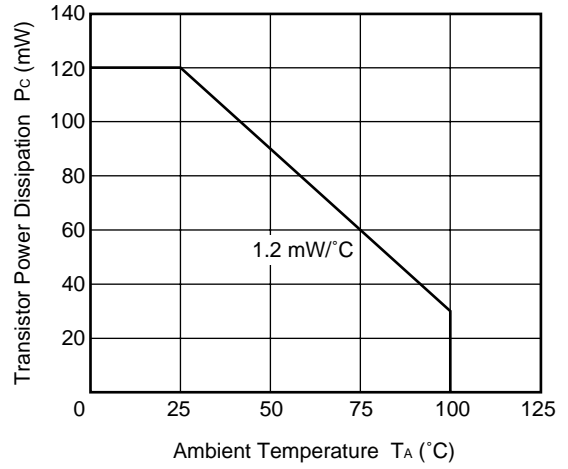

FORWARD CURRENT vs. FORWARD VOLTAGE

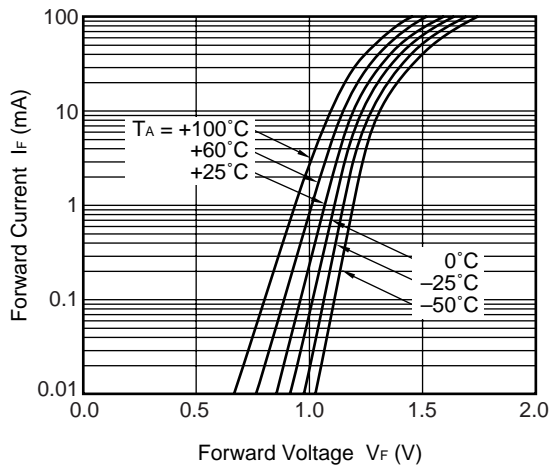

COLLECTOR CURRENT vs. COLLECTOR TO EMITTER VOLTAGE

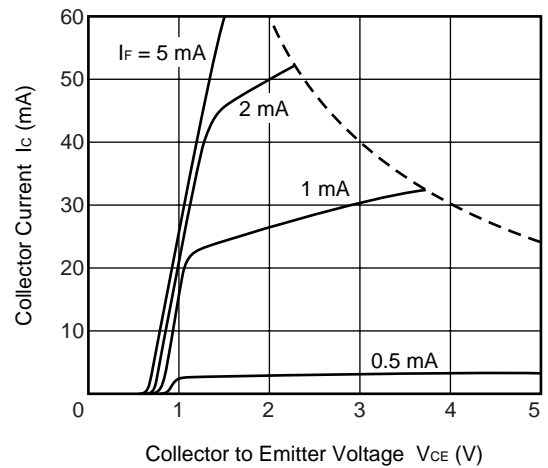

COLLECTOR TO EMITTER DARK CURRENT vs. AMBIENT TEMPERATURE

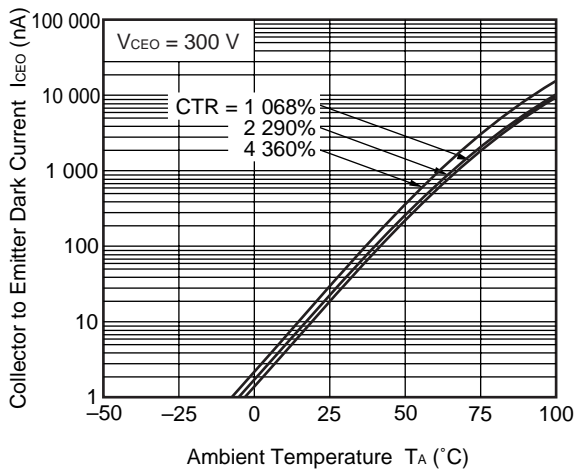

COLLECTOR CURRENT vs. COLLECTOR SATURATION VOLTAGE

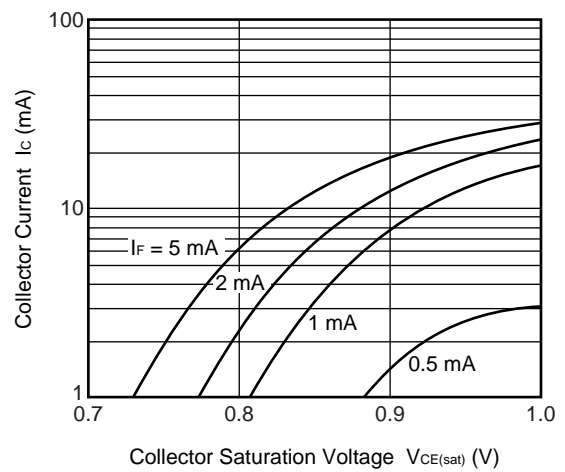

NORMALIZED CURRENT TRANSFER RATIO vs. AMBIENT TEMPERATURE

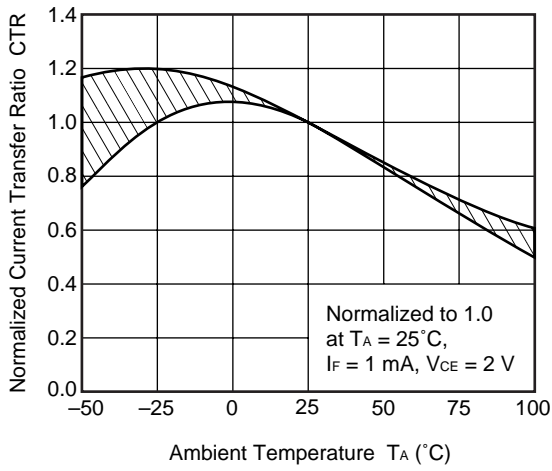

CURRENT TRANSFER RATIO vs. FORWARD CURRENT

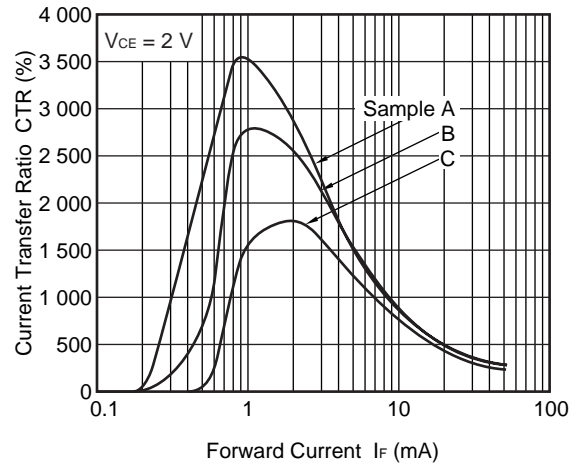

SWITCHING TIME vs. LOAD RESISTANCE

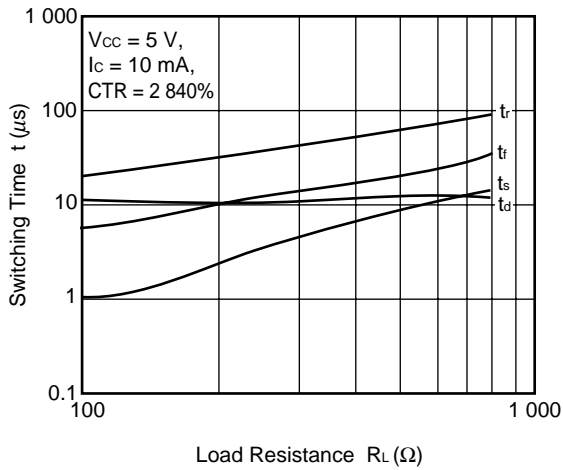

LONG TERM CTR DEGRADATION

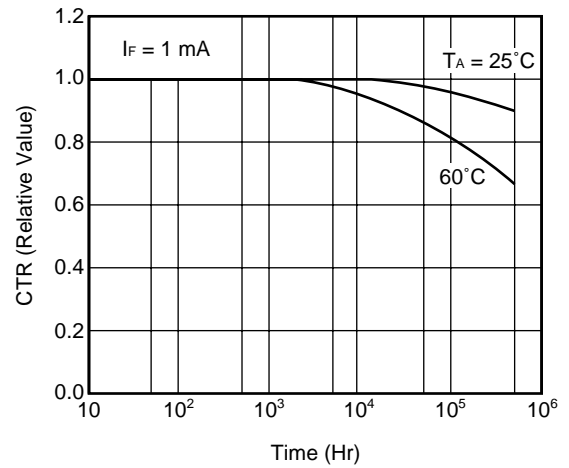

**Remark** The graphs indicate nominal characteristics.

★ TAPING SPECIFICATIONS (UNIT: mm)

Outline and Dimensions (Tape)

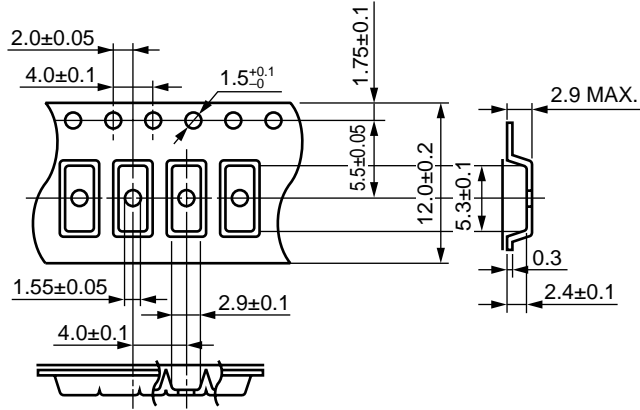

Tape Direction

PS2932-1-F3  
PS2933-1-F3

PS2932-1-F4  
PS2933-1-F4

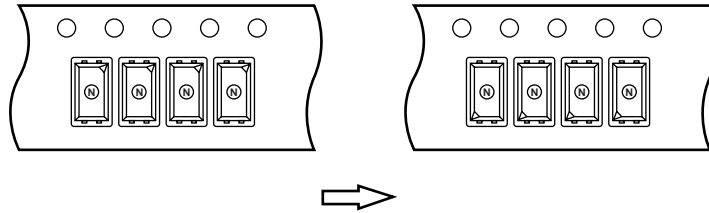

Outline and Dimensions (Reel)

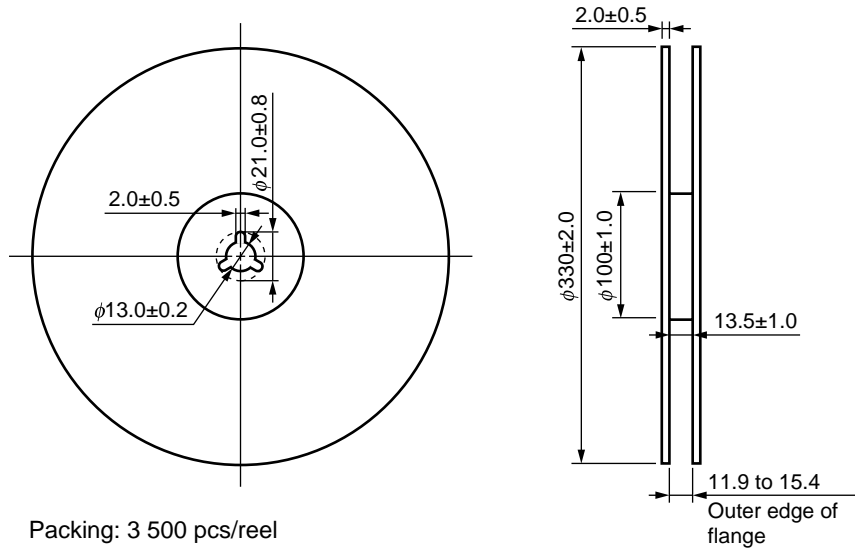

★ RECOMMENDED MOUNT PAD DIMENSIONS (UNIT: mm)

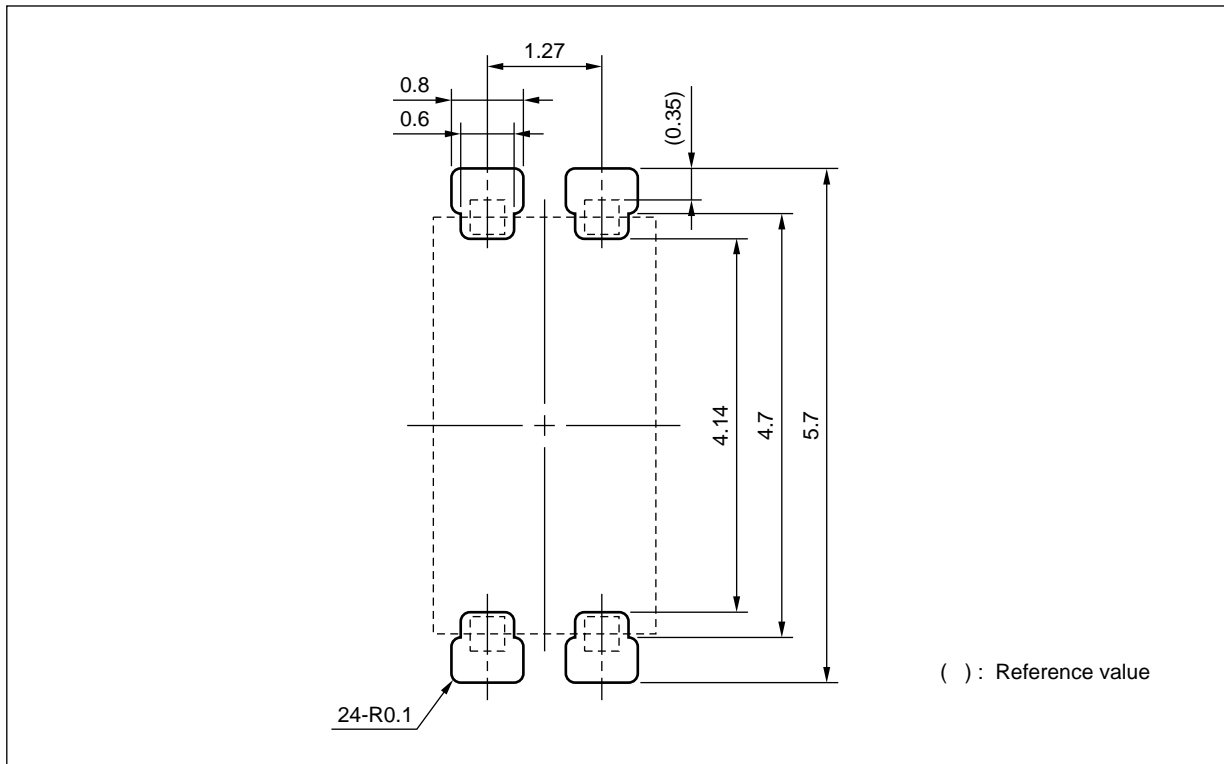

**Remark** This drawing is considered to meet air and outer creepage distance 4.0 mm minimum. All dimensions in this figure must be evaluated before use.

★ **RECOMMENDED SOLDERING CONDITIONS**

**(1) Infrared reflow soldering**

- Peak reflow temperature 260°C or below (package surface temperature)
- Time of peak reflow temperature 10 seconds or less
- Time of temperature higher than 220°C 60 seconds or less
- Time to preheat temperature from 120 to 180°C 120±30 s
- Number of reflows Three
- Flux Rosin flux containing small amount of chlorine (The flux with a maximum chlorine content of 0.2 Wt% is recommended.)

Recommended Temperature Profile of Infrared Reflow

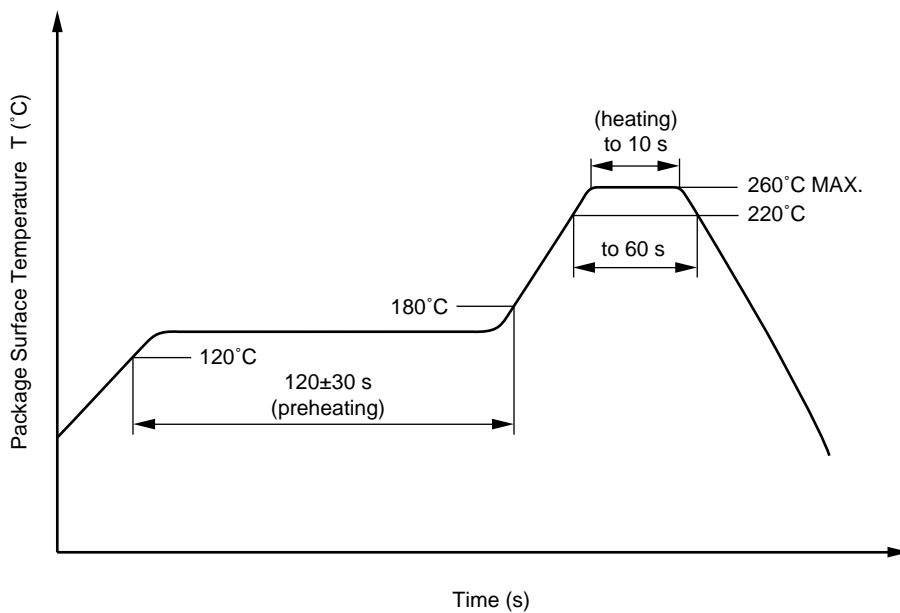

**(2) Wave soldering**

- Temperature 260°C or below (molten solder temperature)
- Time 10 seconds or less
- Preheating conditions 120°C or below (package surface temperature)
- Number of times One (Allowed to be dipped in solder including plastic mold portion.)
- Flux Rosin flux containing small amount of chlorine (The flux with a maximum chlorine content of 0.2 Wt% is recommended.)

**(3) Cautions**

- Fluxes  
Avoid removing the residual flux with freon-based and chlorine-based cleaning solvent.

★ **USAGE CAUTIONS**

1. Protect against static electricity when handling.
2. Avoid storage at a high temperature and high humidity.

- **The information in this document is current as of November, 2001. The information is subject to change without notice. For actual design-in, refer to the latest publications of NEC's data sheets or data books, etc., for the most up-to-date specifications of NEC semiconductor products. Not all products and/or types are available in every country. Please check with an NEC sales representative for availability and additional information.**
  - No part of this document may be copied or reproduced in any form or by any means without prior written consent of NEC. NEC assumes no responsibility for any errors that may appear in this document.
  - NEC does not assume any liability for infringement of patents, copyrights or other intellectual property rights of third parties by or arising from the use of NEC semiconductor products listed in this document or any other liability arising from the use of such products. No license, express, implied or otherwise, is granted under any patents, copyrights or other intellectual property rights of NEC or others.
  - Descriptions of circuits, software and other related information in this document are provided for illustrative purposes in semiconductor product operation and application examples. The incorporation of these circuits, software and information in the design of customer's equipment shall be done under the full responsibility of customer. NEC assumes no responsibility for any losses incurred by customers or third parties arising from the use of these circuits, software and information.
  - While NEC endeavours to enhance the quality, reliability and safety of NEC semiconductor products, customers agree and acknowledge that the possibility of defects thereof cannot be eliminated entirely. To minimize risks of damage to property or injury (including death) to persons arising from defects in NEC semiconductor products, customers must incorporate sufficient safety measures in their design, such as redundancy, fire-containment, and anti-failure features.
  - NEC semiconductor products are classified into the following three quality grades:  
 "Standard", "Special" and "Specific". The "Specific" quality grade applies only to semiconductor products developed based on a customer-designated "quality assurance program" for a specific application. The recommended applications of a semiconductor product depend on its quality grade, as indicated below. Customers must check the quality grade of each semiconductor product before using it in a particular application.  
 "Standard": Computers, office equipment, communications equipment, test and measurement equipment, audio and visual equipment, home electronic appliances, machine tools, personal electronic equipment and industrial robots  
 "Special": Transportation equipment (automobiles, trains, ships, etc.), traffic control systems, anti-disaster systems, anti-crime systems, safety equipment and medical equipment (not specifically designed for life support)  
 "Specific": Aircraft, aerospace equipment, submersible repeaters, nuclear reactor control systems, life support systems and medical equipment for life support, etc.
- The quality grade of NEC semiconductor products is "Standard" unless otherwise expressly specified in NEC's data sheets or data books, etc. If customers wish to use NEC semiconductor products in applications not intended by NEC, they must contact an NEC sales representative in advance to determine NEC's willingness to support a given application.
- (Note)
- (1) "NEC" as used in this statement means NEC Corporation, NEC Compound Semiconductor Devices, Ltd. and also includes its majority-owned subsidiaries.
  - (2) "NEC semiconductor products" means any semiconductor product developed or manufactured by or for NEC (as defined above).

M8E 00.4-0110

**SAFETY INFORMATION ON THIS PRODUCT**

<p><b>Caution</b></p>	<p>GaAs Products</p>	<p>The product contains gallium arsenide, GaAs. GaAs vapor and powder are hazardous to human health if inhaled or ingested.</p> <ul style="list-style-type: none"> <li>• Do not destroy or burn the product.</li> <li>• Do not cut or cleave off any part of the product.</li> <li>• Do not crush or chemically dissolve the product.</li> <li>• Do not put the product in the mouth.</li> </ul> <p>Follow related laws and ordinances for disposal. The product should be excluded from general industrial waste or household garbage.</p>
-----------------------	----------------------	---

► **Business issue**

**NEC Compound Semiconductor Devices, Ltd.**

5th Sales Group, Sales Division TEL: +81-3-3798-6372 FAX: +81-3-3798-6783 E-mail: salesinfo@csd-nec.com

**NEC Compound Semiconductor Devices Hong Kong Limited**

Hong Kong Head Office TEL: +852-3107-7303 FAX: +852-3107-7309  
 Taipei Branch Office TEL: +886-2-8712-0478 FAX: +886-2-2545-3859  
 Korea Branch Office TEL: +82-2-528-0301 FAX: +82-2-528-0302

**NEC Electron Devices European Operations** <http://www.nec.de/>

TEL: +49-211-6503-101 FAX: +49-211-6503-487

**California Eastern Laboratories, Inc.** <http://www.cel.com/>

TEL: +1-408-988-3500 FAX: +1-408-988-0279

► **Technical issue**

**NEC Compound Semiconductor Devices, Ltd.** <http://www.csd-nec.com/>

Sales Engineering Group, Sales Division  
 E-mail: techinfo@csd-nec.com FAX: +81-44-435-1918