

PS710E-1A, PS710EL-1A**6-PIN DIP, 0.08 Ω LOW ON-STATE RESISTANCE
2.0 A CONTINUOUS LOAD CURRENT
1-ch Optical Coupled MOS FET**

-NEPOC Series-

DESCRIPTION

The PS710E-1A and PS710EL-1A are solid state relays containing a GaAs LED on the input side and MOS FETs on the output side.

It is suitable for PLC, etc. because of its large continuous load current and low on-state resistance.

The PS710EL-1A has a surface mount type lead.

FEATURES

- Low on-state resistance ($R_{on} = 0.08 \Omega$ TYP.)
- Large continuous load current ($I_L = 2.0 A$)
- 1 channel type (1 a output)
- Low LED operating current ($I_F = 2 mA$)
- Designed for AC/DC switching line changer
- Small package (6-pin DIP)
- Low offset voltage
- PS710EL-1A: Surface mount type

APPLICATIONS

- Measurement equipment
- FA equipment

The information in this document is subject to change without notice. Before using this document, please confirm that this is the latest version.
Not all devices/types available in every country. Please check with local NEC Compound Semiconductor Devices representative for availability and additional information.

PACKAGE DIMENSIONS (UNIT: mm)

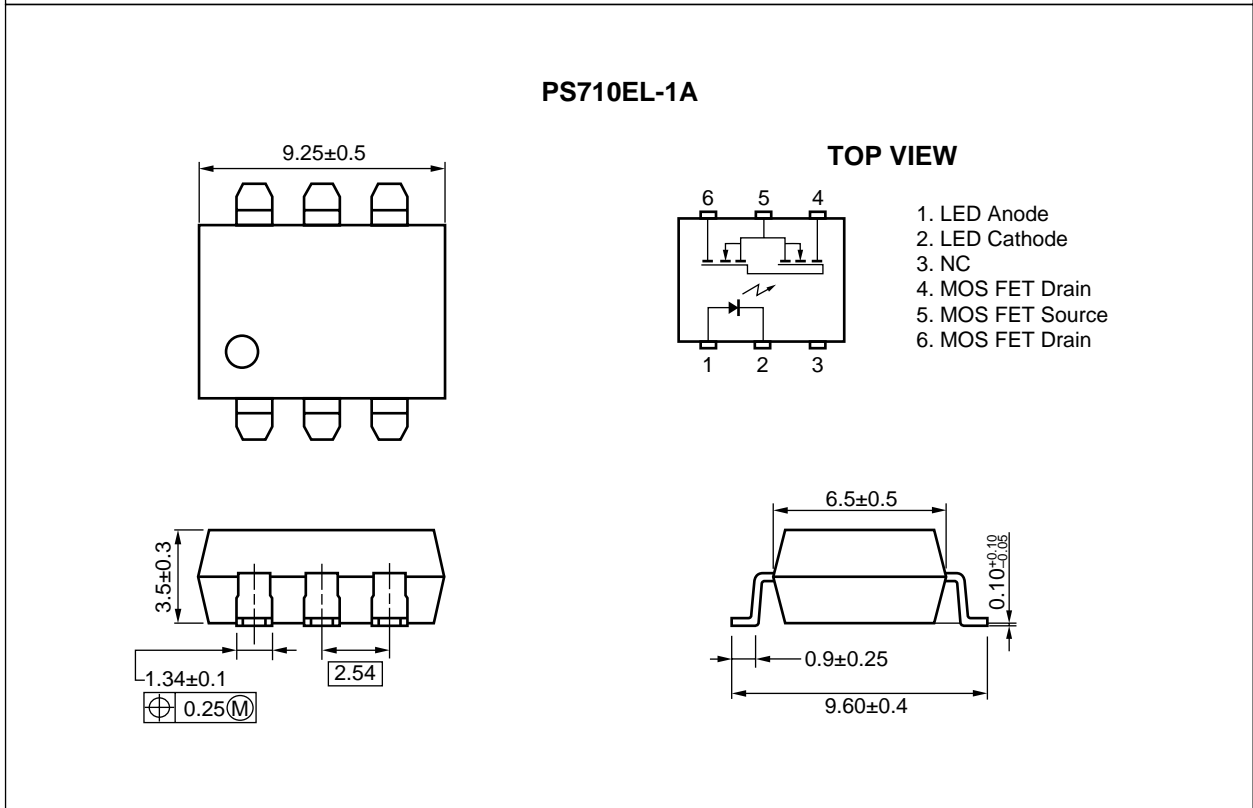
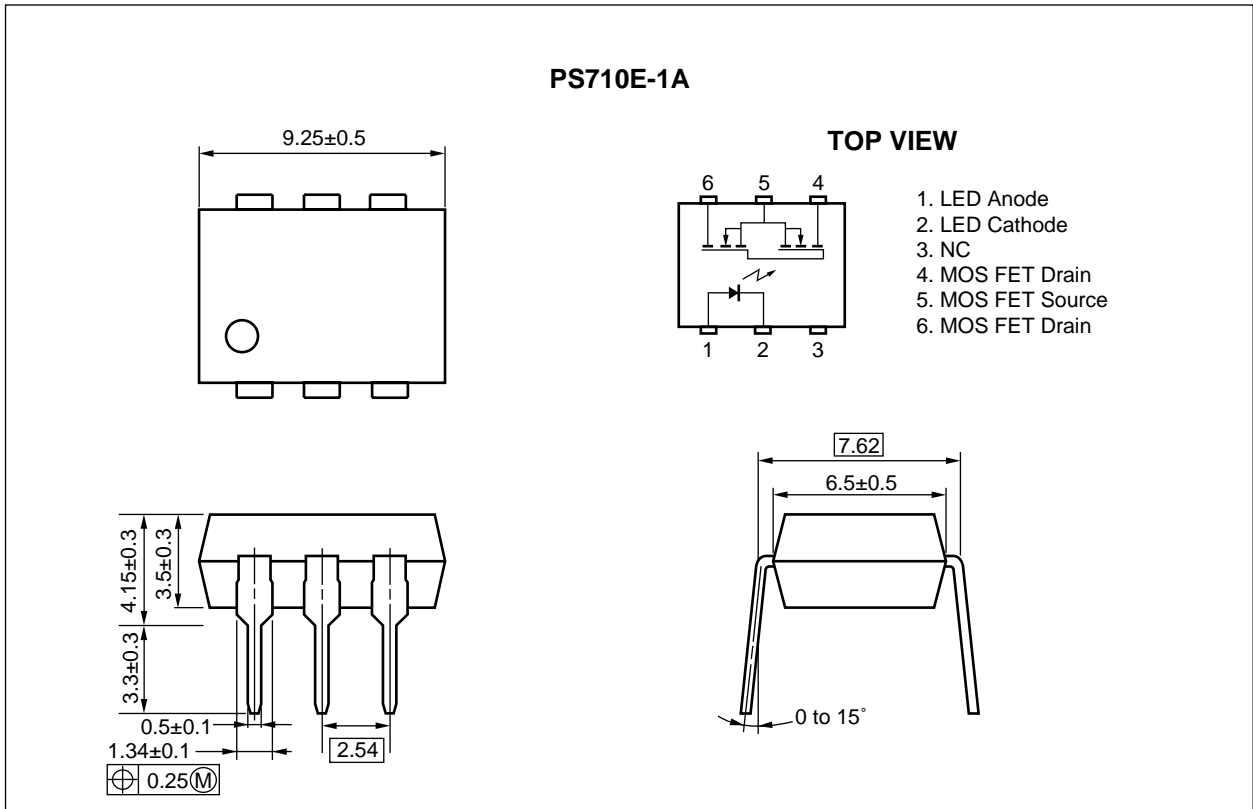

MARKING EXAMPLE

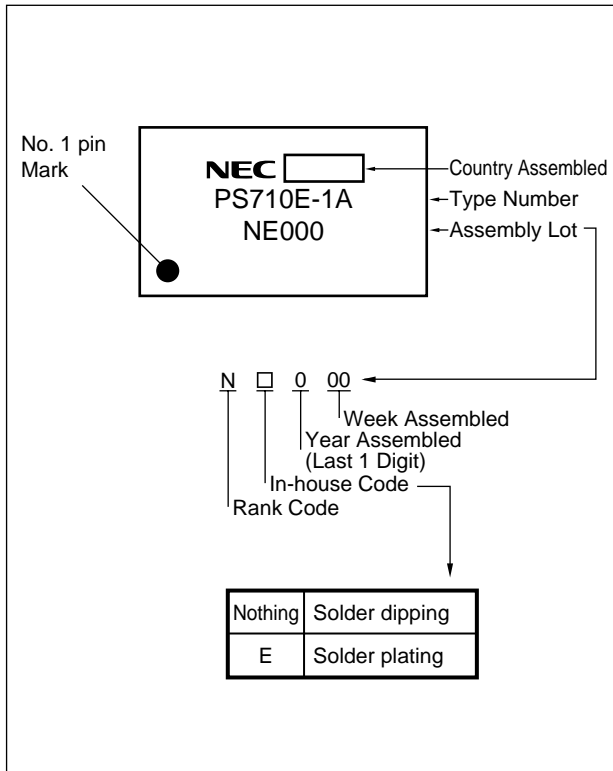

ORDERING INFORMATION

Part Number	Package	Packing Style	Application Part Number ^{*1}
PS710E-1A	6-pin DIP	Magazine case 50 pcs	PS710E-1A
PS710EL-1A			PS710EL-1A
PS710EL-1A-E3		Embossed tape 1 000 pcs/reel	
PS710EL-1A-E4			

*1 For the application of the Safety Standard, following part number should be used.

ABSOLUTE MAXIMUM RATINGS (T_A = 25°C, unless otherwise specified)

Parameter		Symbol	Ratings	Unit	
Diode	Forward Current (DC)	I _F	50	mA	
	Reverse Voltage	V _R	5.0	V	
	Power Dissipation	P _D	50	mW	
	Peak Forward Current ^{*1}	I _{FP}	1	A	
MOS FET	Load Voltage	V _L	80	V	
	Continuous Load Current ^{*2}	Connection A	I _L	2.0	A
		Connection B		3.0	
		Connection C		4.0	
	Pulse Load Current ^{*3} (AC/DC Connection)	I _{LP}	4.0	A	
Power Dissipation	P _D	600	mW		
Isolation Voltage ^{*4}		BV	1 500	V _{r.m.s.}	
Total Power Dissipation		P _T	650	mW	
Operating Ambient Temperature		T _A	-40 to +85	°C	
Storage Temperature		T _{stg}	-40 to +100	°C	

*1 PW = 100 μs, Duty Cycle = 1%

*2 Conditions: I_F ≥ 2 mA. The following types of load connections are available.

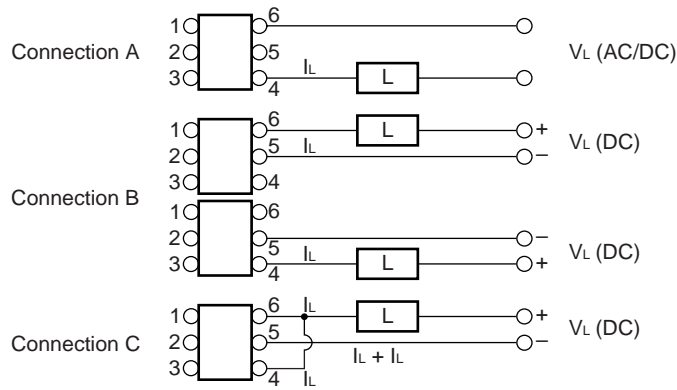

*3 PW = 100 ms, 1 shot

*4 AC voltage for 1 minute at T_A = 25°C, RH = 60% between input and output

RECOMMENDED OPERATING CONDITIONS (T_A = 25°C)

Parameter	Symbol	MIN.	TYP.	MAX.	Unit
LED Operating Current	I _F	2	10	20	mA
LED Off Voltage	V _F	0		0.5	V

ELECTRICAL CHARACTERISTICS (T_A = 25°C)

Parameter		Symbol	Conditions	MIN.	TYP.	MAX.	Unit
Diode	Forward Voltage	V _F	I _F = 10 mA		1.2	1.4	V
	Reverse Current	I _R	V _R = 5 V			5.0	μA
MOS FET	Off-state Leakage Current	I _{Loff}	V _D = 80 V			50	nA
	Output Capacitance	C _{out}	V _D = 0 V, f = 1 MHz		480		pF
Coupled	LED On-state Current	I _{Fon}	I _L = 2.0 A			2.0	mA
	On-state Resistance	R _{on}	I _F = 10 mA, I _L = 2.0 A, t ≤ 10 ms		0.083	0.15	Ω
	Turn-on Time ^{*1,2}	t _{on}	I _F = 10 mA, V _O = 5 V, R _L = 500 Ω,		1.0	2.0	ms
	Turn-off Time ^{*1,2}	t _{off}	PW ≥ 10 ms		0.02	0.2	
	Isolation Resistance	R _{I-O}	V _{I-O} = 1.0 kV _{DC}		10 ⁹		Ω
	Isolation Capacitance	C _{I-O}	V = 0 V, f = 1 MHz			0.5	pF

***1 Test Circuit for Switching Time**

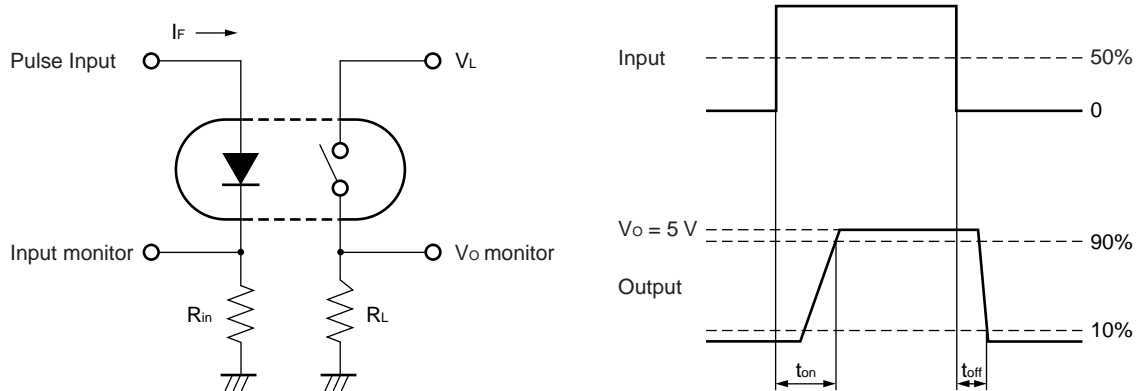

***2** The turn-on time and turn-off time are specified as input-pulse width ≥ 10 ms.

Be aware that when the device operates with an input-pulse width of under 10 ms, the turn-on time and turn-off time will increase.

TYPICAL CHARACTERISTICS (T_A = 25°C, unless otherwise specified)

MAXIMUM FORWARD CURRENT vs. AMBIENT TEMPERATURE

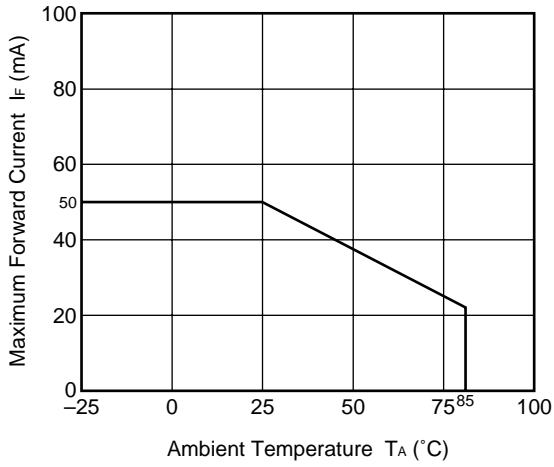

MAXIMUM LOAD CURRENT vs. AMBIENT TEMPERATURE

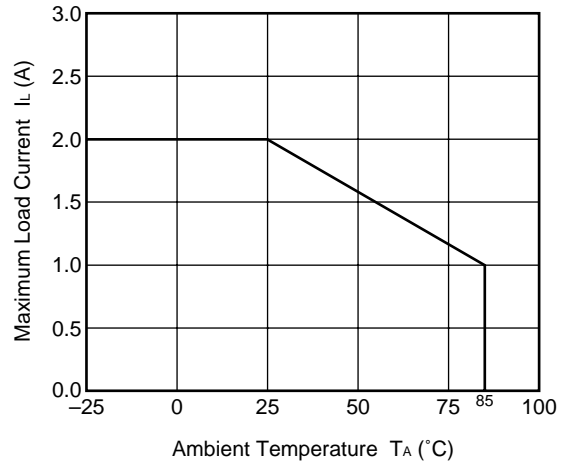

FORWARD VOLTAGE vs. AMBIENT TEMPERATURE

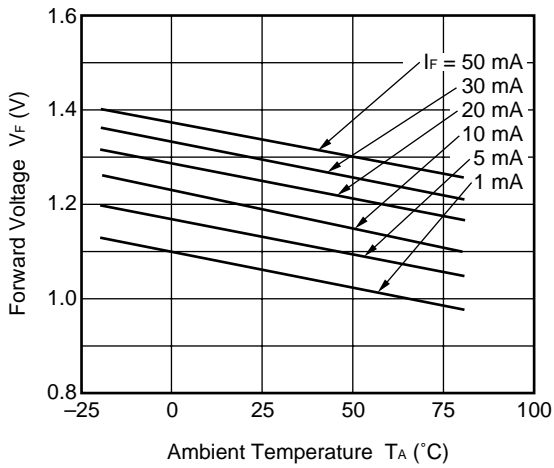

OUTPUT CAPACITANCE vs. APPLIED VOLTAGE

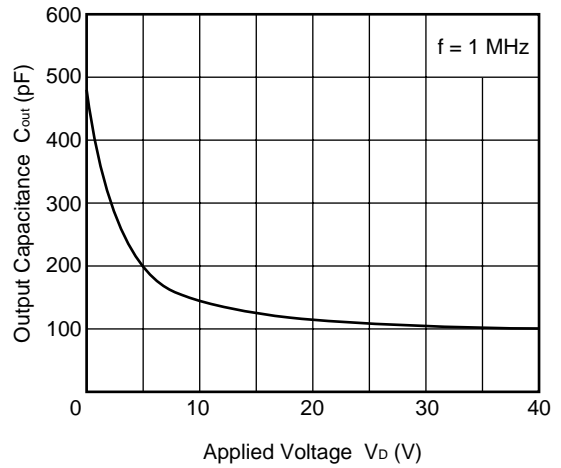

OFF-STATE LEAKAGE CURRENT vs. AMBIENT TEMPERATURE

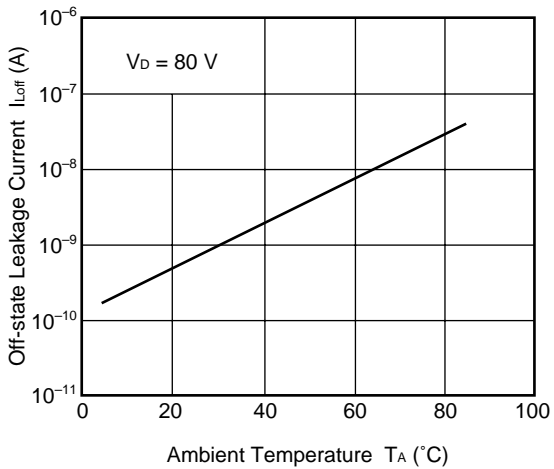

LOAD CURRENT vs. LOAD VOLTAGE

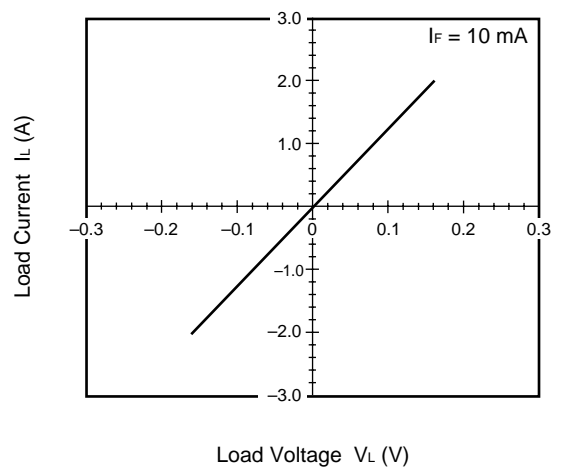

NORMALIZED ON-STATE RESISTANCE vs. AMBIENT TEMPERATURE

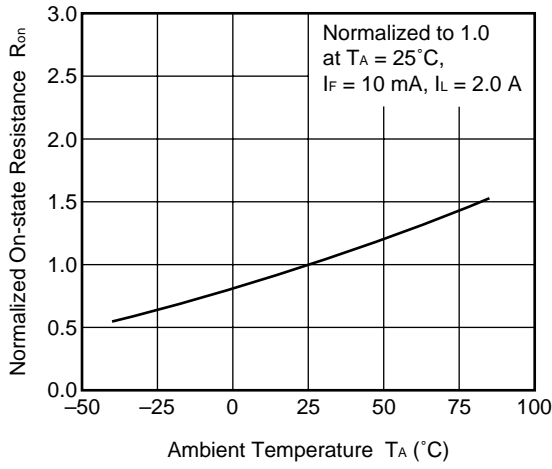

ON-STATE RESISTANCE DISTRIBUTION

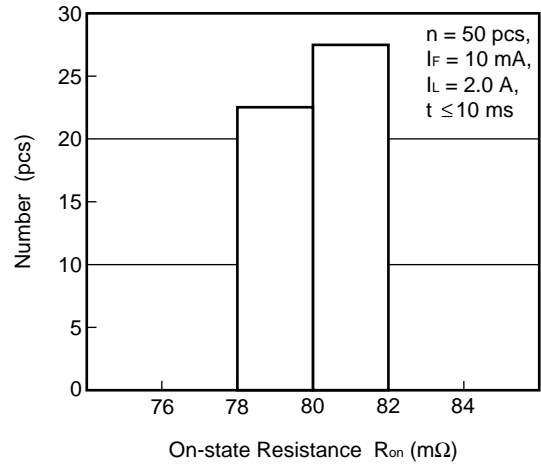

TURN-ON TIME vs. FORWARD CURRENT

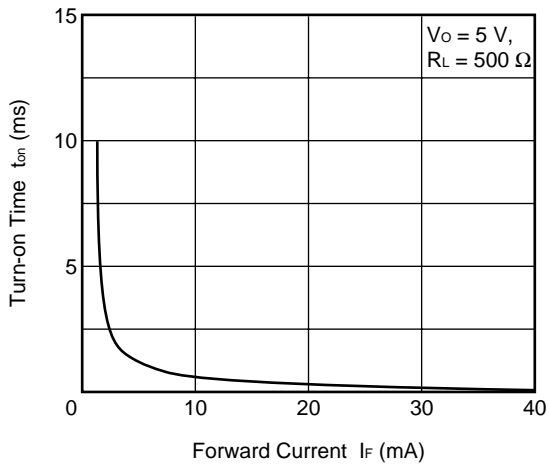

TURN-OFF TIME vs. FORWARD CURRENT

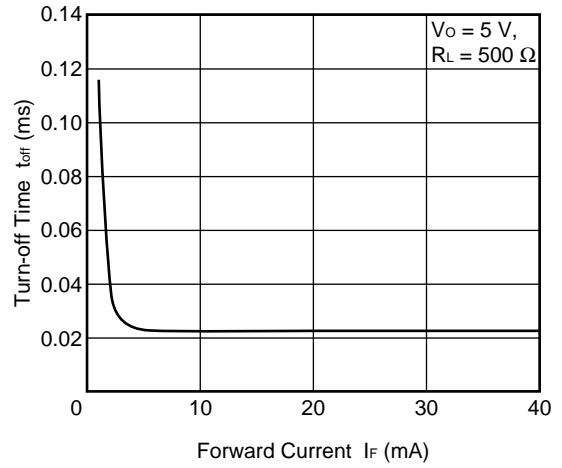

TURN-ON TIME DISTRIBUTION

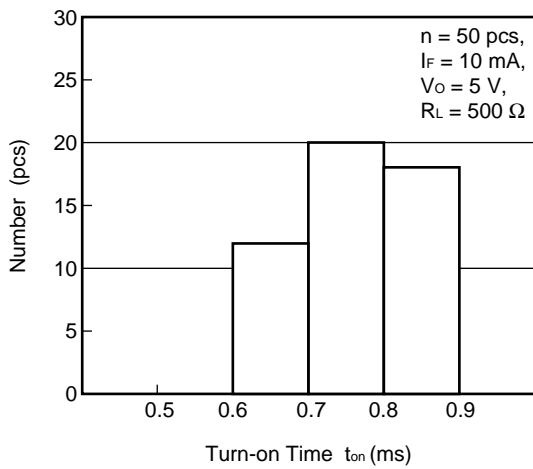

TURN-OFF TIME DISTRIBUTION

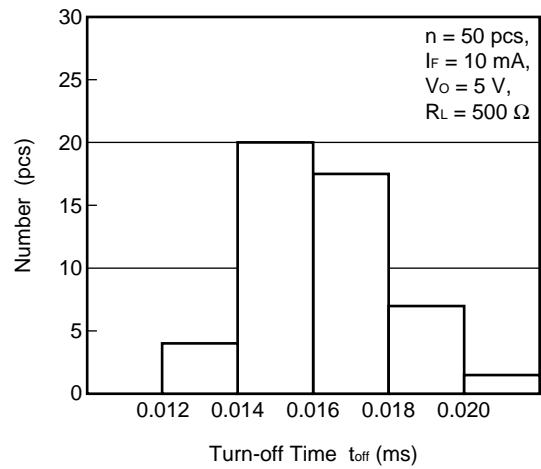

NORMALIZED TURN-ON TIME vs. AMBIENT TEMPERATURE

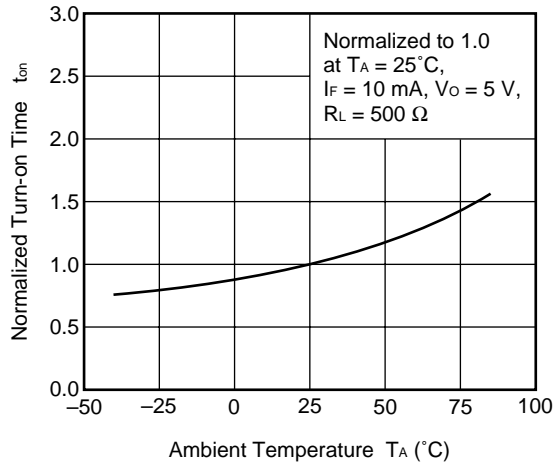

NORMALIZED TURN-OFF TIME vs. AMBIENT TEMPERATURE

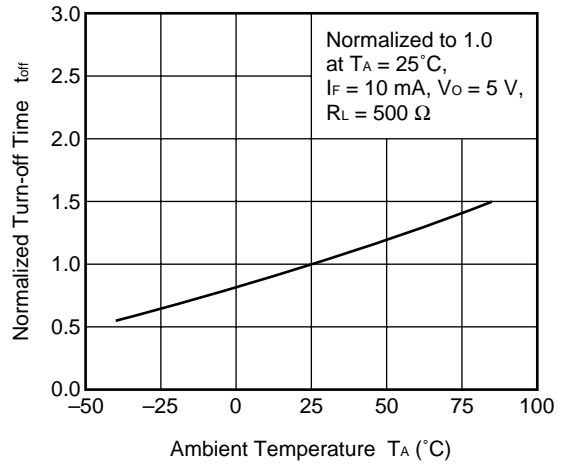

Remark The graphs indicate nominal characteristics.

TAPING SPECIFICATIONS (UNIT: mm)

Outline and Dimensions (Tape)

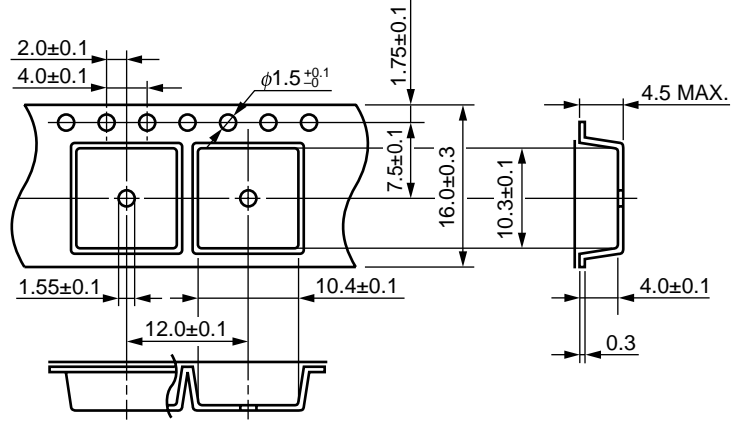

Tape Direction

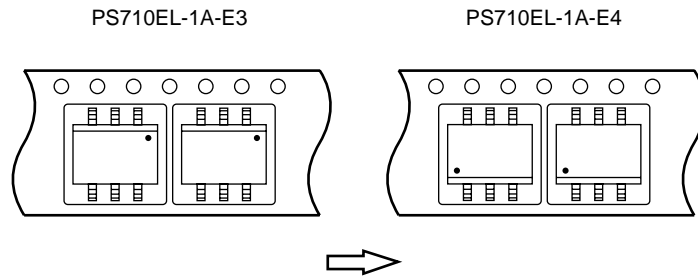

Outline and Dimensions (Reel)

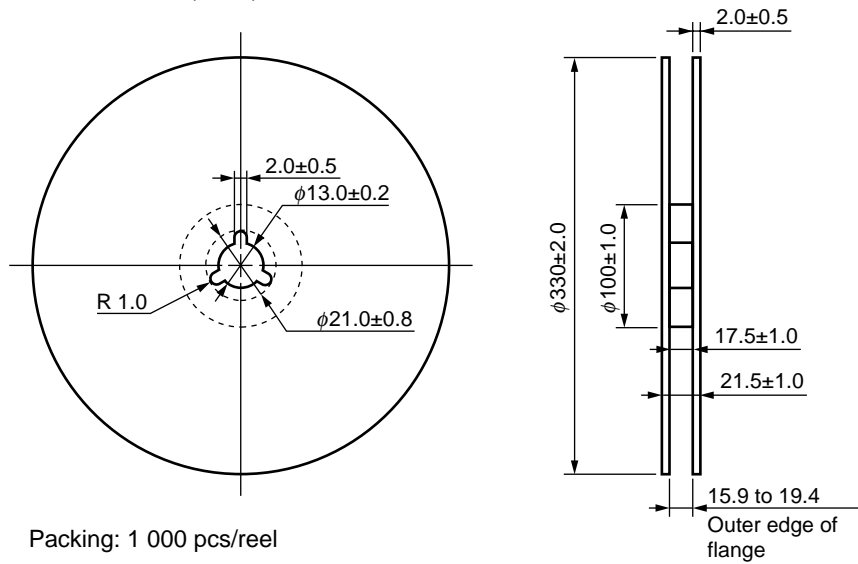

RECOMMENDED SOLDERING CONDITIONS

(1) Infrared reflow soldering

- Peak reflow temperature 260°C or below (package surface temperature)
- Time of peak reflow temperature 10 seconds or less
- Time of temperature higher than 220°C 60 seconds or less
- Time to preheat temperature from 120 to 180°C 120±30 s
- Number of reflows Three
- Flux Rosin flux containing small amount of chlorine (The flux with a maximum chlorine content of 0.2 Wt% is recommended.)

Recommended Temperature Profile of Infrared Reflow

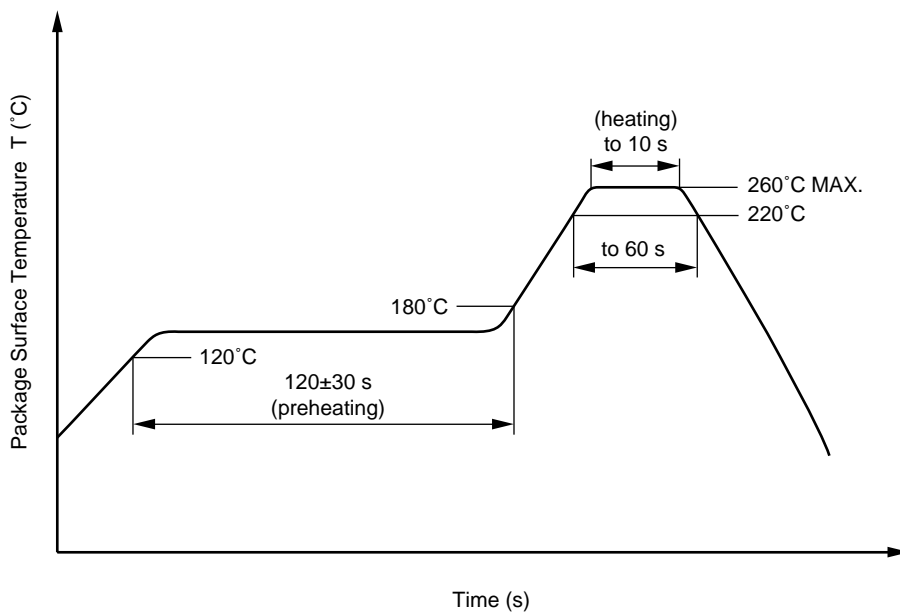

(2) Wave soldering

- Temperature 260°C or below (molten solder temperature)
- Time 10 seconds or less
- Preheating conditions 120°C or below (package surface temperature)
- Number of times One
- Flux Rosin flux containing small amount of chlorine (The flux with a maximum chlorine content of 0.2 Wt% is recommended.)

(3) Cautions

- Fluxes
Avoid removing the residual flux with freon-based and chlorine-based cleaning solvent.

- **The information in this document is current as of April 2002. The information is subject to change without notice. For actual design-in, refer to the latest publications of NEC's data sheets or data books, etc., for the most up-to-date specifications of NEC semiconductor products. Not all products and/or types are available in every country. Please check with an NEC sales representative for availability and additional information.**
 - No part of this document may be copied or reproduced in any form or by any means without prior written consent of NEC. NEC assumes no responsibility for any errors that may appear in this document.
 - NEC does not assume any liability for infringement of patents, copyrights or other intellectual property rights of third parties by or arising from the use of NEC semiconductor products listed in this document or any other liability arising from the use of such products. No license, express, implied or otherwise, is granted under any patents, copyrights or other intellectual property rights of NEC or others.
 - Descriptions of circuits, software and other related information in this document are provided for illustrative purposes in semiconductor product operation and application examples. The incorporation of these circuits, software and information in the design of customer's equipment shall be done under the full responsibility of customer. NEC assumes no responsibility for any losses incurred by customers or third parties arising from the use of these circuits, software and information.
 - While NEC endeavours to enhance the quality, reliability and safety of NEC semiconductor products, customers agree and acknowledge that the possibility of defects thereof cannot be eliminated entirely. To minimize risks of damage to property or injury (including death) to persons arising from defects in NEC semiconductor products, customers must incorporate sufficient safety measures in their design, such as redundancy, fire-containment, and anti-failure features.
 - NEC semiconductor products are classified into the following three quality grades:
 "Standard", "Special" and "Specific". The "Specific" quality grade applies only to semiconductor products developed based on a customer-designated "quality assurance program" for a specific application. The recommended applications of a semiconductor product depend on its quality grade, as indicated below. Customers must check the quality grade of each semiconductor product before using it in a particular application.
 "Standard": Computers, office equipment, communications equipment, test and measurement equipment, audio and visual equipment, home electronic appliances, machine tools, personal electronic equipment and industrial robots
 "Special": Transportation equipment (automobiles, trains, ships, etc.), traffic control systems, anti-disaster systems, anti-crime systems, safety equipment and medical equipment (not specifically designed for life support)
 "Specific": Aircraft, aerospace equipment, submersible repeaters, nuclear reactor control systems, life support systems and medical equipment for life support, etc.
- The quality grade of NEC semiconductor products is "Standard" unless otherwise expressly specified in NEC's data sheets or data books, etc. If customers wish to use NEC semiconductor products in applications not intended by NEC, they must contact an NEC sales representative in advance to determine NEC's willingness to support a given application.
- (Note)
- (1) "NEC" as used in this statement means NEC Corporation, NEC Compound Semiconductor Devices, Ltd. and also includes its majority-owned subsidiaries.
 - (2) "NEC semiconductor products" means any semiconductor product developed or manufactured by or for NEC (as defined above).

M8E 00.4-0110

SAFETY INFORMATION ON THIS PRODUCT

<p>Caution</p>	<p>GaAs Products</p>	<p>The product contains gallium arsenide, GaAs. GaAs vapor and powder are hazardous to human health if inhaled or ingested.</p> <ul style="list-style-type: none"> • Do not destroy or burn the product. • Do not cut or cleave off any part of the product. • Do not crush or chemically dissolve the product. • Do not put the product in the mouth. <p>Follow related laws and ordinances for disposal. The product should be excluded from general industrial waste or household garbage.</p>
-----------------------	----------------------	---

► **Business issue**

NEC Compound Semiconductor Devices, Ltd.

5th Sales Group, Sales Division TEL: +81-3-3798-6372 FAX: +81-3-3798-6783 E-mail: salesinfo@csd-nec.com

NEC Compound Semiconductor Devices Hong Kong Limited

Hong Kong Head Office TEL: +852-3107-7303 FAX: +852-3107-7309
 Taipei Branch Office TEL: +886-2-8712-0478 FAX: +886-2-2545-3859
 Korea Branch Office TEL: +82-2-528-0301 FAX: +82-2-528-0302

NEC Electron Devices European Operations <http://www.nec.de/>

TEL: +49-211-6503-101 FAX: +49-211-6503-487

California Eastern Laboratories, Inc. <http://www.cel.com/>

TEL: +1-408-988-3500 FAX: +1-408-988-0279

► **Technical issue**

NEC Compound Semiconductor Devices, Ltd. <http://www.csd-nec.com/>

Sales Engineering Group, Sales Division
 E-mail: techinfo@csd-nec.com FAX: +81-44-435-1918