

TRANSISTOR MODULE

QCA200AA120

TOP



UL;E76102 (M)

QCA200AA120 is a dual Darlington power transistor module with has series-connected high speed, high power Darlington transistors. Each transistor has a reverse paralleled fast recovery diode. The mounting base of the module is electrically isolated from semiconductor elements for simple heatsink construction.

- $I_C=200A$, $V_{CEX}=1200V$
- Low saturation voltage for higher efficiency
- High DC current gain h_{FE}
- Isolated monuting base

(Applications)

Motor Control (VVF), AC/DC Servo, UPS,
Switching Power Supply, Ultrasonic Application

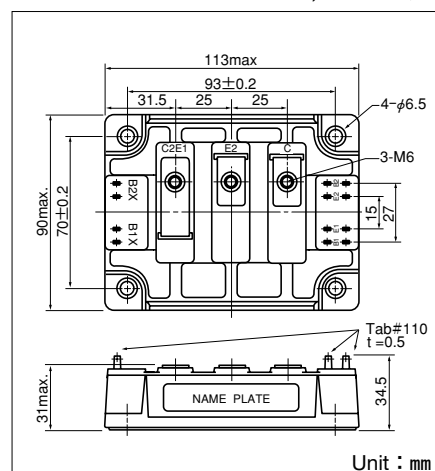
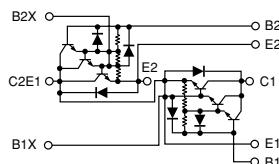

Maximum Ratings

($T_j=25^{\circ}C$ unless otherwise specified)

Symbol	Item	Conditions	Ratings		Unit
			QCA200AA120		
V_{CBO}	Collector-Base Voltage	Emitter open	1200		V
V_{CEX}	Collector-Emitter Voltage	$V_{BE}=-2V$	1200		V
$V_{CEX(SUS)}$	Collector-Emitter Sustaining Voltage	$I_C=40A$, $I_{B2}=-5A$	1200		V
V_{EBO}	Emitterr-Base Voltage	Collector open	10		V
I_C	Collector Current		200		A
$-I_C$	Reverse Collector Current		200		A
I_B	Base Current		10		A
P_C	Collector-Emitter power dissipation	$T_C=25^{\circ}C$	1560		W
T_j	Junction Temperature		-40 to 150		$^{\circ}C$
T_{stg}	Storage Temperature		-40 to 125		$^{\circ}C$
V_{iso}	Isolation Voltage(RMS)	A.C. 1minute	2500		V
	Mounting Torque(M6)	Recommended Value 2.5-3.9 (25-40)	4.7 (48)		N·m (kgf·cm)
	Mass	Typical Value	675		g

Electrical Characteristics

Symbol	Item	Conditions	Ratings		Unit
			Min.	Max	
I_{CBO}	Collector Cut-off Current	$V_{CB}=1000V$ Emttter open		4.00	mA
I_{EBO}	Emitter Cut-off Current	$V_{EB}=10V$ Collector open		500	mA
h_{FE}	D.C. Current Gain	$I_C=200A$, $V_{CE}=5V$	75		
$V_{CE(sat)}$	Collector-Emitter Sturation Voltage	$I_C=200A$, $I_B=4A$		3.0	V
$V_{BE(sat)}$	Base-Emitter Saturation Voltage	$I_C=200A$, $I_B=4A$		3.5	V
t_{on}	Switching Time	On Time		3.0	μs
t_{stg}		Storage Time	$V_{CC}=600V$, $I_C=200A$ $I_{B1}=4A$, $I_{B2}=-4A$	15.00	
t_f		Fall Time		3.0	
V_{ECO}	Collector-Emitter Reverse Voltage (Diode forward voltage drop)	$-I_C=200A$		1.8	V
$R_{th(j-c)}$	Thermal Impedance (Junction to case)	Transistor part		0.08	$^{\circ}C/W$
		Diode part		0.35	

