

TRANSISTOR MODULE (Hi-β)

QCA75BA60



UL;E76102(M)

QCA75BA60 is a dual Darlington power transistor module which has series-connected **ULTRA HIGH** h_{FE} , high speed, high power Darlington transistors. Each transistor has a reverse paralleled fast recovery diode (t_{rr} : 200ns). The mounting base of the module is electrically isolated from Semiconductor elements for simple heatsink construction,

- $I_C=75A$, $V_{CEX}=600V$
- Low saturation voltage for higher efficiency.
- **ULTRA HIGH** DC current gain h_{FE} . $h_{FE} \geq 750$
- Isolated mounting base
- V_{EBO} 10V for faster switching speed.

(Applications)

Motor Control (VWVF), AC/DC Servo, UPS,
Switching Power Supply, Ultrasonic Application

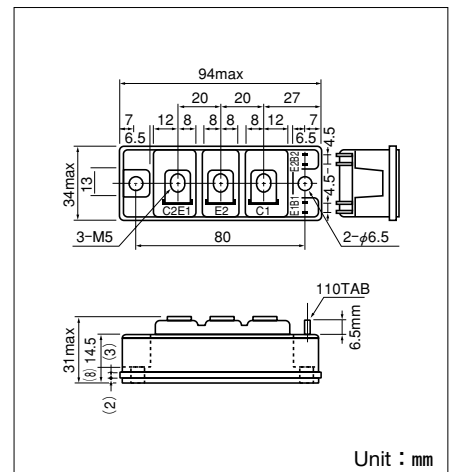
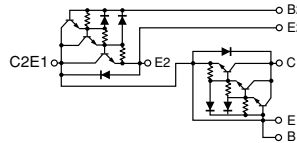

Unit : mm

Maximum Ratings

($T_j=25^\circ C$ unless otherwise specified)

Symbol	Item	Conditions	Ratings		Unit
			QCA75BA60		
V_{CBO}	Collector-Base Voltage		600		V
V_{CEX}	Collector-Emitter Voltage	$V_{BE} = -2V$	600		V
V_{EBO}	Emitter-Base Voltage		10		V
I_C	Collector Current	() $p_w \leq 1ms$	75 (150)		A
$-I_C$	Reverse Collector Current		75		A
I_B	Base Current		4.5		A
P_T	Total power dissipation	$T_C=25^\circ C$	350		W
T_j	Junction Temperature		-40 to +150		$^\circ C$
T_{stg}	Storage Temperature		-40 to +125		$^\circ C$
V_{ISO}	Isolation Voltage	A.C.1minute	2500		V
	Mounting Torque	Mounting (M6)	Recommended Value 2.5-3.9 (25-40)		N·m kgf·cm
		Termnal (M5)	Recommended Value 1.5-2.5 (15-25)		
	Mass	Typical Value	240		g

Electrical Characteristics

Symbol	Item	Conditions	Ratings			Unit
			Min.	Typ.	Max.	
I_{CBO}	Collector Cut-off Current	$V_{CB} = V_{CBO}$			1.0	mA
I_{EBO}	Emitter Cut-off Current	$V_{EB} = V_{EBO}$			300	mA
$V_{CEO(SUS)}$	Collector Emitter Sustaning Voltage	$I_C=1A$	450			V
$V_{CEX(SUS)}$		$I_C=15A, I_{B2}=-5A$	600			
h_{FE}	D.C. Current Gain	$I_C=75A, V_{CE}=2.5V$	750			
$V_{CE(sat)}$	Collector-Emitter Saturation Voltage	$I_C=75A, I_B=100mA$			2.5	V
$V_{BE(sat)}$	Base-Emitter Saturation Voltage	$I_C=75A, I_B=100mA$			3.0	V
t_{on}	Switching Time	On Time			2.0	μs
t_s		Storage Time	$V_{CC}=300V, I_C=75A$ $I_{B1}=150mA, I_{B2}=-1.5A$		8.0	
t_f		Fall Time			2.0	
V_{ECO}	Collector-Emitter Reverse Voltage	$I_C=-75A$			1.8	V
t_{rr}	Reverse Recovery time	$V_{CC}=300V, -I_C=75A, -di/dt=75A/\mu A, V_{BE}=-5V$		200		ns
$R_{th(j-c)}$	Thermal Impedance (junction to case)	transistor part			0.35	$^\circ C/W$
		Diode part			1.3	

