

PHOTOFLASH RECTIFIER

VOLTAGE RANGE 1000 to 1800 Volts CURRENT 0.5 Ampere

FEATURES

- * High reliability
- * Low leakage
- * Low forward voltage drop
- * High current capability

MECHANICAL DATA

- * Case: Molded plastic
- * Epoxy: UL 94V-O rate flame retardant
- * Lead: MIL-STD-202E method 208C guaranteed
- * Mounting position: Any
- * Weight: 0.20 gram

MAXIMUM RATINGS AND ELECTRICAL CHARACTERISTICS

Ratings at 25 °C ambient temperature unless otherwise specified.
 Single phase, half wave, 60 Hz, resistive or inductive load.
 For capacitive load, derate current by 20%.

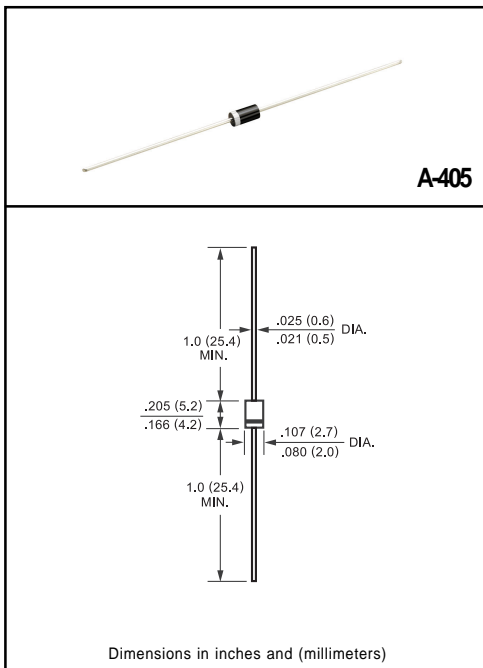

Dimensions in inches and (millimeters)

MAXIMUM RATINGS (At TA = 25°C unless otherwise noted)

RATINGS	SYMBOL	RL1N1000F	RL1N1200F	RL1N1400F	RL1N1600F	RL1N1800F	UNITS
Maximum Recurrent Peak Reverse Voltage	VRRM	1000	1200	1400	1600	1800	Volts
Maximum RMS Voltage	VRMS	700	840	980	1120	1260	Volts
Maximum DC Blocking Voltage	VDC	1000	1200	1400	1600	1800	Volts
Maximum Average Forward Current at TA = 55°C	IO	500					Amps
Peak Forward Surge Current IFM (surge): 8.3 ms single half sine-wave superimposed on rated load (JEDEC method)	IFSM	25					Amps
Typical Junction Capacitance (Note 2)	CJ	10					pF
Operating and Storage Temperature Range	TJ, TSTG	-65 to + 175					°C

ELECTRICAL CHARACTERISTICS (At TA = 25°C unless otherwise noted)

CHARACTERISTICS	SYMBOL	RL1N1000F	RL1N1200F	RL1N1400F	RL1N1600F	RL1N1800F	UNITS
Maximum Instantaneous Forward Voltage at 0.5A DC	VF	1.8					Volts
Maximum DC Reverse Current at Rated DC Blocking Voltage TA = 25°C	IR	5.0					uAmps
Maximum Full Load Reverse Current Average, Full Cycle .375" (9.5mm) lead length at TL = 55°C		100					uAmps
Maximum Reverse Recovery Time (Note 1)	trr	300					nSec

NOTES : 1. Test Conditions: IF = 0.5A, IR = 1.0A, IRR = 0.25A
 2. Measured at 1 MHz and applied reverse voltage of 4.0 volts

RATING AND CHARACTERISTIC CURVES (RL1N1000F THRU RL1N1800F)

FIG. 1 - FORWARD CURRENT DERATING CURVE

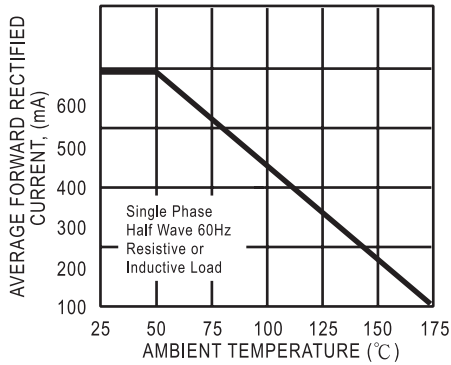

FIG. 2 - TYPICAL INSTANTANEOUS FORWARD CHARACTERISTICS

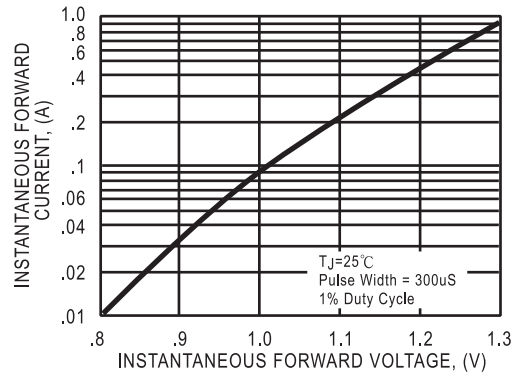

FIG. 3 - MAXIMUM NON-REPETITIVE SURGE CURRENT

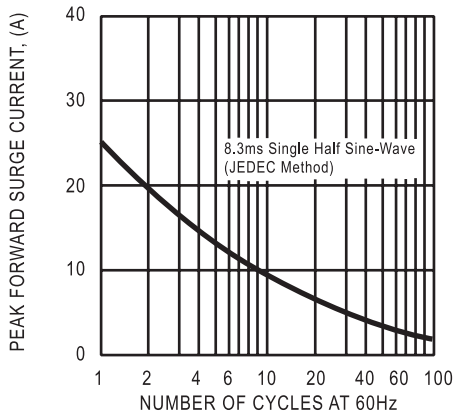

FIG. 4 - TYPICAL JUNCTION CAPACITANCE

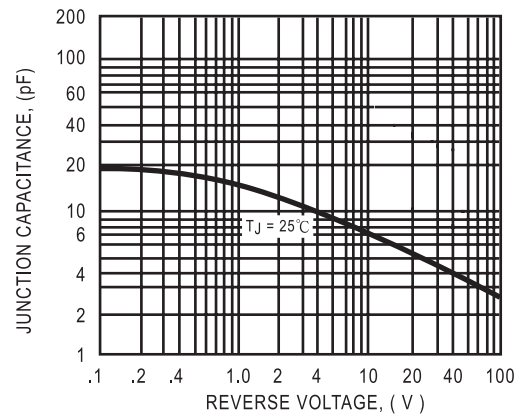
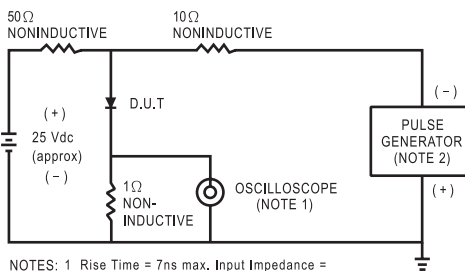

FIG. 1 - TEST CIRCUIT DIAGRAM AND REVERSE RECOVERY TIME CHARACTERISTIC



- NOTES: 1 Rise Time = 7ns max. Input Impedance = 1 megohm, 22pF.
2. Rise Time = 10ns max. Source Impedance = 50 ohms.

