

RM3283

Dual ARINC 429 Line Receiver

Features

- Two separate analog receiver channels
- Converts ARINC 429 levels to serial data
- Built-in TTL compatible complete channel test inputs
- TTL and CMOS compatible outputs
- Low power dissipation
- Internal bandgap
- Short circuit protected
- MIL-STD-883B screening available for ceramic packages
- Available in 20-Lead ceramic DIP, 20-Terminal LCC, and 20-Lead SOIC

Description

The RM3283 consists of two analog ARINC 429 receivers which take differentially encoded ARINC level data and convert it to serial TTL level data. The RM3283 provides two complete analog ARINC receivers and no external components are required.

Input level shifting thin film resistors and bipolar technology allow ARINC input voltage transients up to $\pm 100V$ without damage to the RM3283.

Each channel is identical, featuring symmetrical propagation delays for better high speed performance. Input common mode rejection is excellent and threshold voltage is stable, independent of supply voltage. Data outputs are TTL and CMOS compatible.

Two TTL compatible test inputs used to test the ARINC channels are available. They can be used to override the ARINC input data and set the channel outputs to a known state.

The Fairchild RM3182/RM3182A line driver is the companion chip to the RM3283 line receiver. Together they provide the analog functions needed for the ARINC 429 interface. Digital data processing involving serial-to-parallel conversion and clock recovery can be accomplished using one of the ARINC interface IC's available or by an equivalent gate array implementation.

Block Diagram

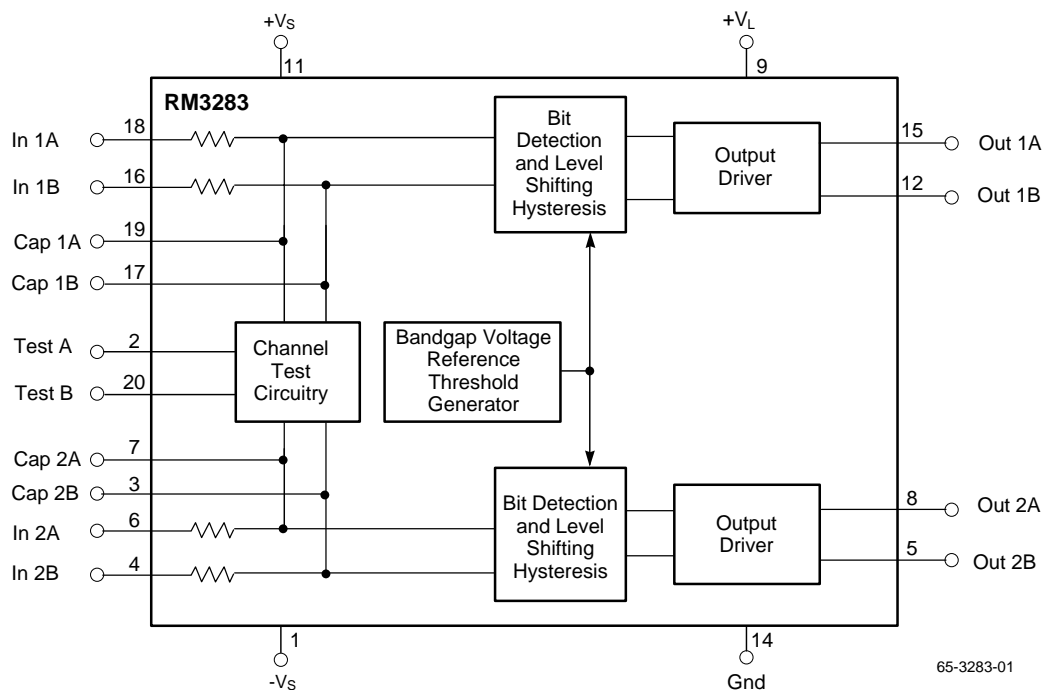

Functional Description

The RM3283 contains two discrete ARINC 429 receiver channels. Each channel contains three main sections: a resistor input network, a window comparator, and a logic output buffer stage. The first stage provides overvoltage protection and biases the signal using voltage dividers and current sources, providing excellent input common mode rejection. The test inputs are provided to set the outputs to a predetermined state for built-in channel test capability. If the test inputs are not used, they should be grounded.

The window comparator section detects data from the resistor input network. A Logic 1 corresponds to ARINC “High” state (OutA) and a Logic 0, to ARINC “Low” state (OutB). An ARINC “Null” state at the inputs forces both outputs to Logic 0. Threshold and hysteresis voltages are generated by a bandgap voltage reference to maintain stable switching characteristics over temperature and power supply variations.

The output stage generates a TTL compatible logic output capable of driving 3mA of load.

Pin Assignments

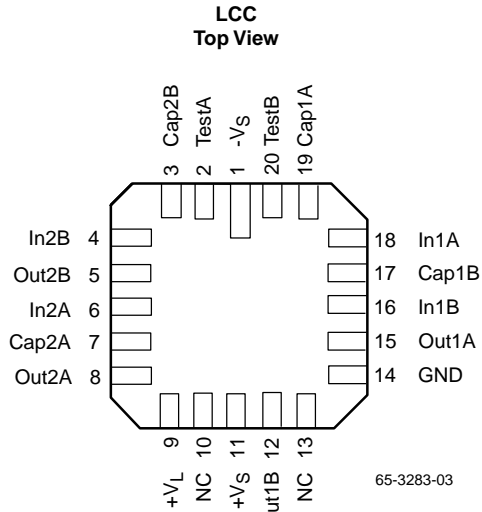
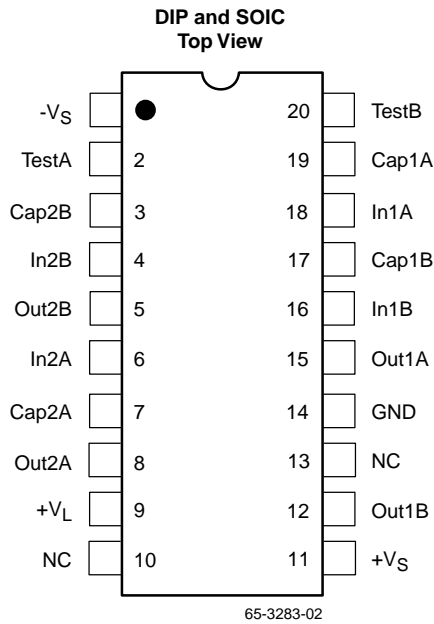

Absolute Maximum Ratings

Parameter		Min.	Max.	Units
Supply Voltage (VCC to VEE)			+36	V
VLOGIC Voltage			+7	V
Logic Input Voltage		-0.3	VLOGIC + 0.3	V
Temperature Range	Storage	-65	+150	°C
	Operating	-55	+125	°C
Junction Temperature		-55	+175	°C
Lead Soldering Temperature	60 sec., DIP, LCC		+300	°C
	10 sec., SOIC		+260	°C

Thermal Characteristics (Still air, soldered on a PC board)

Parameter	LCC	DIP	SOIC
Maximum Junction Temperature	+175°C	+175°C	+125°C
Thermal Resistance, θ_{JC}	85°C/W	70°C/W	85°C/W
Thermal Resistance, θ_{JC}	20°C/W ¹	28°C/W ¹	30°C/W

Note:

- MIL-STD-1835.

DC Electrical Characteristics

$T_A = -55^\circ\text{C}$ to $+125^\circ\text{C}$, $\pm 12\text{V} \leq V_S \leq \pm 15\text{V}$, $V_L = +5\text{V}$, unless otherwise noted.

Symbol	Parameter	Conditions	Min.	Typ.	Max.	Units
I_{CC} (+VS)	Test inputs = 0V			4.3	6.0	mA
I_{EE} (-VS)	Test inputs = 0V			10.1	12.0	mA
I_L (V_L)	Test inputs = 5V			14.0	17.5	mA
V_{TL}^2	V(A)-V(B)	Low threshold	4.7	5.0	5.3	V
V_{TH}^2	V(A)-V(B)	High threshold	5.7	6.0	6.3	V
V_{IN}	V(A)-V(B)	OutA and OutB = 0	-2.5	0	2.5	V
V_{IC}^3	V(A) and V(B)-GND	Maximum common mode frequency = 80 kHz		± 5		V
R_I	Input resistance, Input A to Input B		35	50		k Ω
R_H	Input resistance, Input A to Gnd		20	25		k Ω
R_G	Input resistance, B to Gnd	Filter caps disconnected	20	25		k Ω
$C_I^{1,4}$	Input capacitance, A to B				10	pF
$C_H^{1,4}$	Input capacitance, A to Gnd	Filter caps disconnected			10	pF
$C_G^{1,4}$	Input capacitance, B to Gnd	Filter caps disconnected			10	pF
Test Inputs (TestA, TestB)						
V_{IH}^5	Logic 1 input voltage		2.7			V
V_{IL}^5	Logic 0 input voltage		0		0.8	V
I_{IH}	Logic 1 input current	$V_{IH} = 5\text{V}$		120	300	μA
I_{IL}	Logic 0 input current	$V_{IL} = 0.8\text{V}$		15	40	μA
Outputs						
V_{OH}	$I_{OH} = 100 \mu\text{A}$	$T_A = 25^\circ\text{C}$	4.0	4.3		V
	$I_{OH} = 2.8 \text{mA}$	Full temperature range	3.5	4.0		V
V_{OL}	$I_{OL} = 100 \mu\text{A}$	$T_A = 25^\circ\text{C}$		0.02	0.1	V
	$I_{OL} = 2.0 \text{mA}$	Full temperature range		0	0.8	V
T_r^6	Rise Time	$C_L = 50 \text{pF}$, @ 25°C		50	70	ns
T_f^6	Fall Time	$C_L = 50 \text{pF}$, @ 25°C		40	70	ns
T_{PLH}	Propagation delay Output low to high	$C_L = 50 \text{pF}$, $f = 400 \text{kHz}$ Filter caps = 39 pF		700		ns
T_{PHL}	Output high to low	$T_A = 25^\circ\text{C}$		700		ns

Notes:

- As stated in ARINC429.
- V_T refers to the threshold voltage at which the channels output switches from low to high or from high to low.
- Common mode voltage present at both ARINC inputs.
- Guaranteed by design.
- Test inputs should be connected to ground if not used.
- Sample tested.

Typical Performance Characteristics

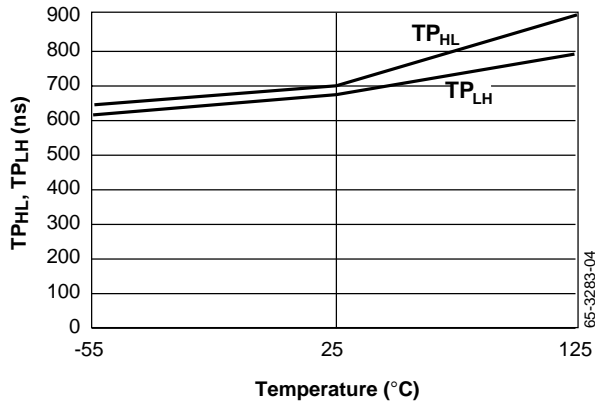

Figure 1. Propagation Delay vs. Temperature
 $C_L = 50 \text{ pF}$, $C_{FILTER} = 39 \text{ pF}$

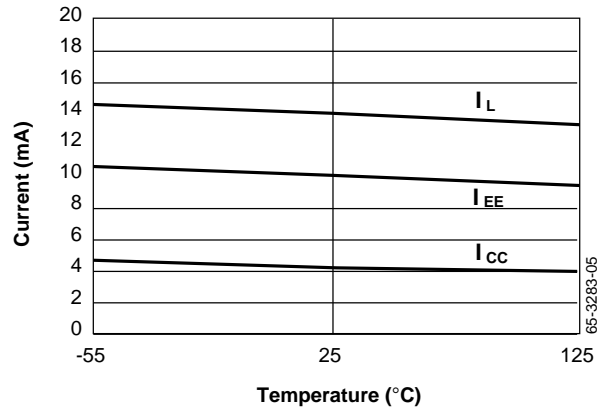

Figure 2. Supply Current vs. Temperature

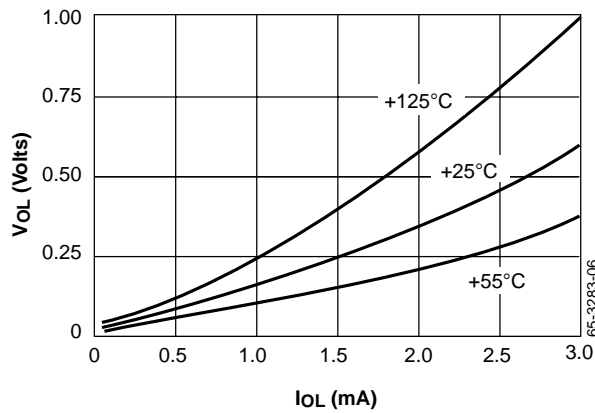

Figure 3. Output Voltage Low vs. Output Current

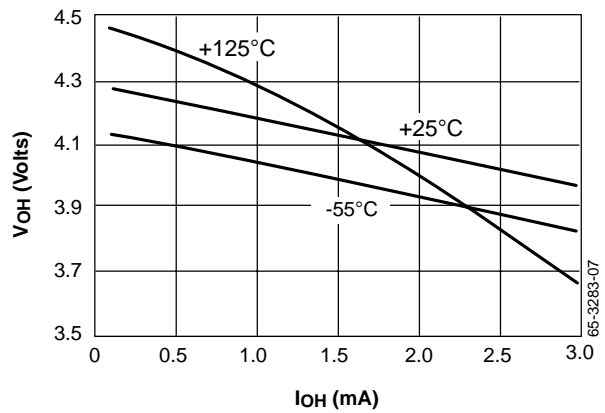

Figure 4. Output Voltage High vs. Output Current

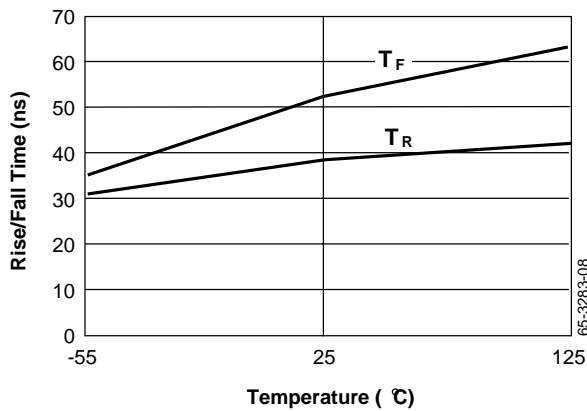

Figure 5. T_R and T_F vs. Temperature

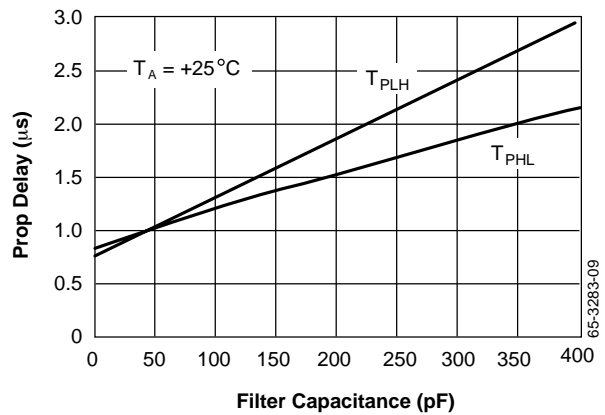

Figure 6. Propagation Delay vs. Filter Capacitance
 $T_A = 25^\circ\text{C}$

AC Test Waveforms

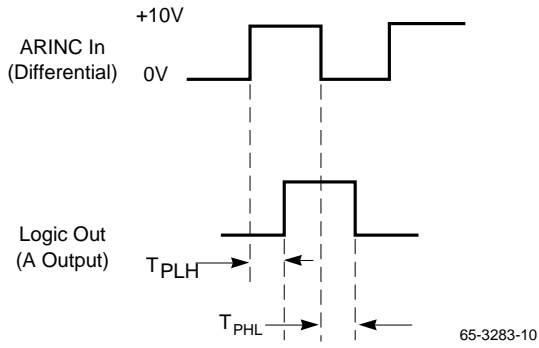

Figure 7. Propagation Delay

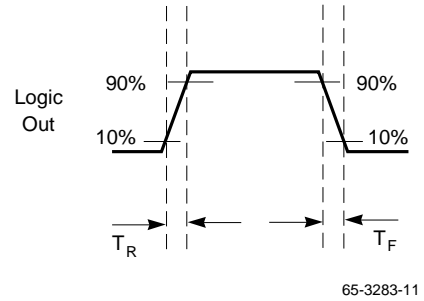
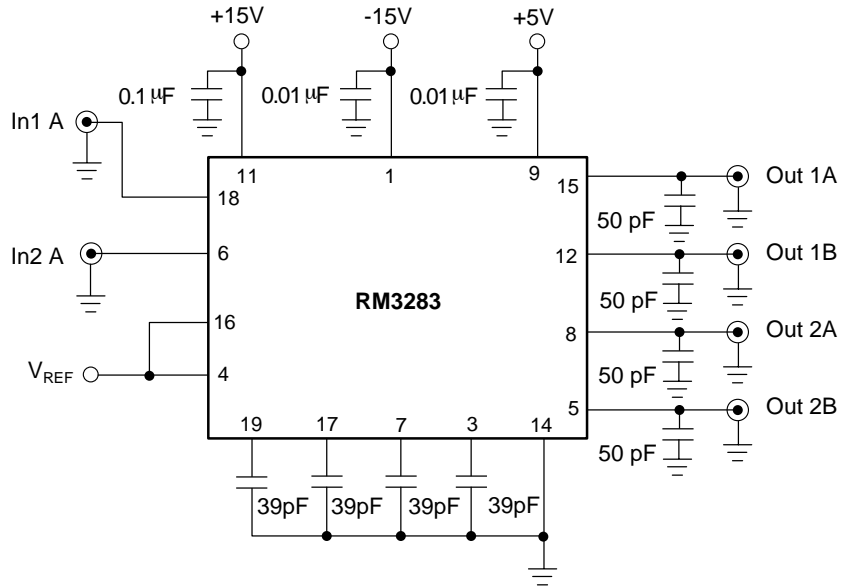

Figure 8. Rise/Fall Times

Test Circuit



Notes:

1. V_{IN} = 400 kHz square wave, -3.5V to +3.5V.
2. Set V_{REF} = +3.5 V to test V_{OUT1} and V_{OUT3} .
Set V_{REF} = -3.5 V to test V_{OUT2} and V_{OUT4} .
3. 50 pF load capacitance includes probe and wiring capacitance.

65-3283-12

Figure 9. AC Test Schematic Diagram

Truth Table

ARINC nputs V(A) - V(B)	Test Inputs		Outputs		Output State
	TESTA	TESTB	OUTA	OUTB	
Null	0	0	0	0	Null
Low	0	0	0	1	Low
High	0	0	1	0	High
X	0	1	0	1	Low
X	1	0	1	0	High
X	1	1	0	0	Null

Applications Discussion

The standard connections for the RM3283 are shown in Figure 10. Dual supplies from ± 12 to ± 15 VDC are recommended for the $\pm V_S$ supplies. Decoupling of all supplies should be done near the IC to avoid propagation of noise spikes due to switching transients. The ground connection should be sturdy and isolated from large switching currents to provide as quiet a ground reference as possible.

The noise filter capacitors are optional and are added to provide extra noise immunity by limiting bandwidth of the input signal before it reaches the window comparator stage. Two capacitors are required for each channel and they must all be the same value. The suggested capacitor value for a 100 kHz operation is 39 pF. For lower data rates, larger values of capacitance may be used to yield better node perfor-

mance. To get optimum performance, the following equation can be used to calculate capacitor value for a specific data rate:

$$C_{\text{FILTER}} = \frac{3.95 \times 10^{-6}}{F_O}$$

Where C_{FILTER} is the capacitor value in pF, and F_O is the input frequency ($10 \text{ kHz} \leq F_O \leq 150 \text{ kHz}$).

The RM3283 can be used with the Fairchild RM3182/RM3182A line driver to provide a complete analog ARINC 429 interface. A simple application which can be used for systems requiring a repeater-type circuit for long transmissions is given in Figure 11. More RM3182 drivers may be added to test multiple ARINC channels, as shown.

Applications

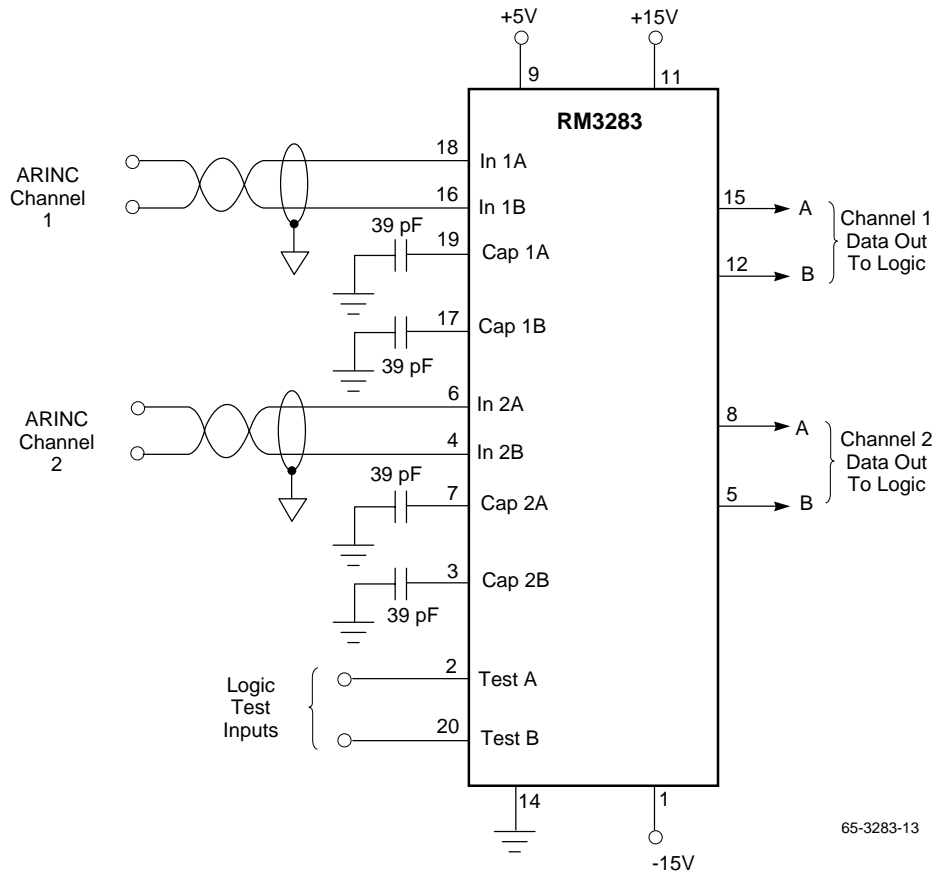

65-3283-13

Figure 10. ARINC Receiver Standard Connections

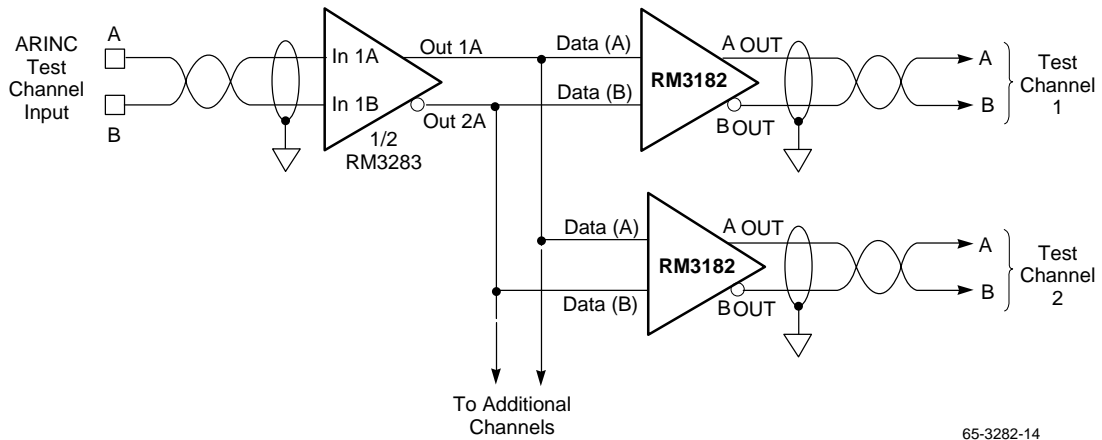

65-3282-14

Figure 11. Repeater Circuit

Applications (continued)

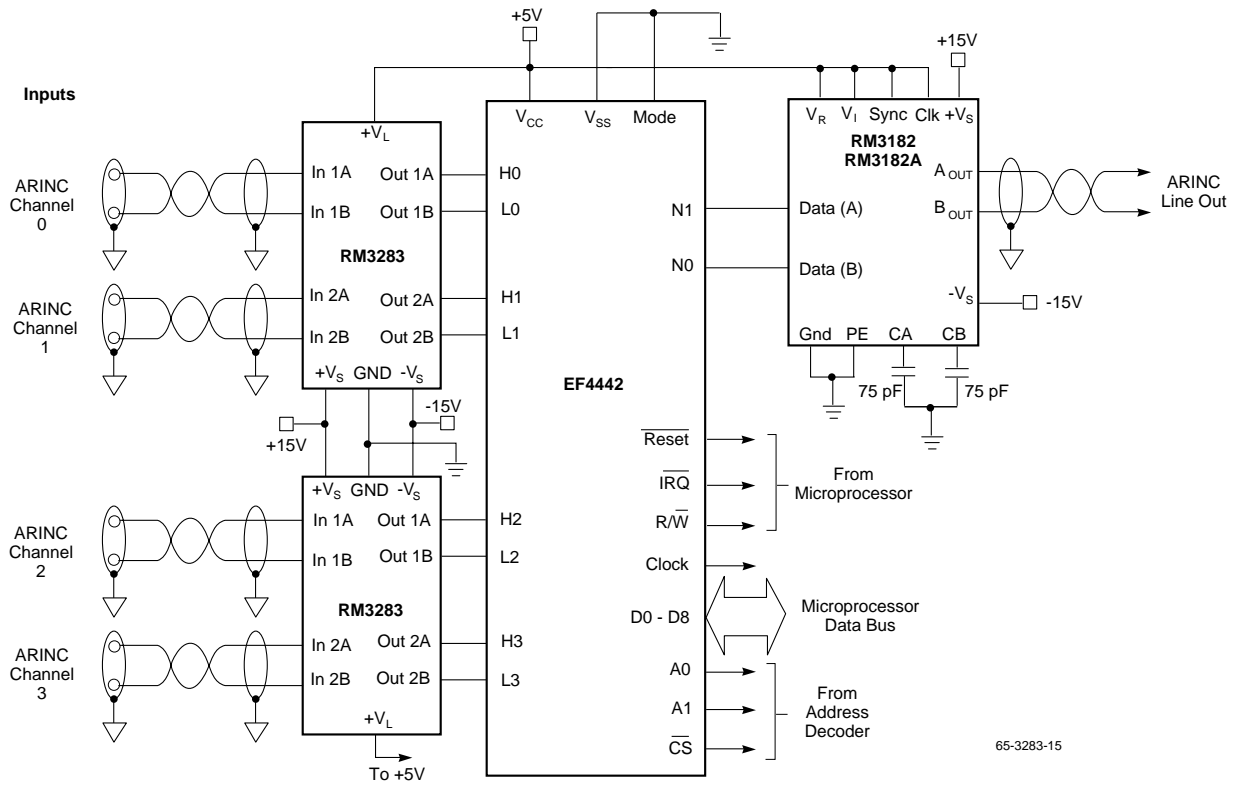

Figure 12. Four-Channel ARINC Receiver Circuit

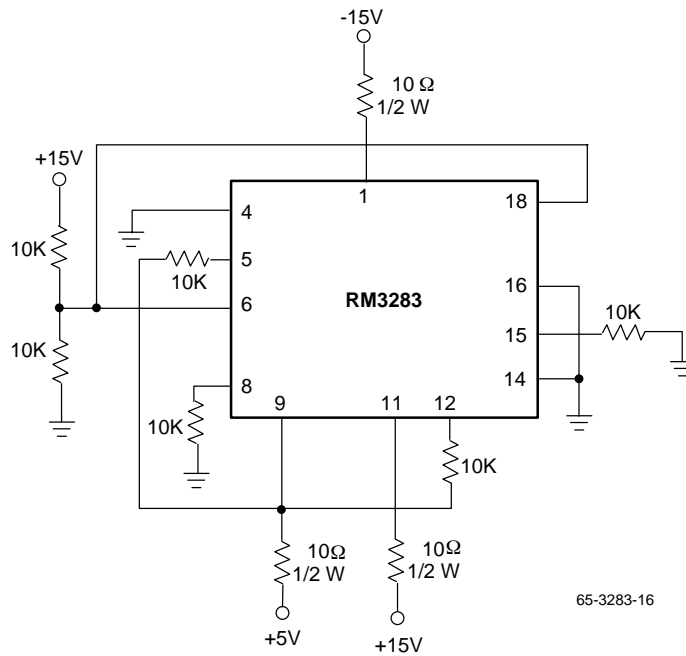

Figure 13. Burn-In Circuit

Mechanical Dimensions

20-Lead SOIC

Symbol	Inches		Millimeters		Notes
	Min.	Max.	Min.	Max.	
A	.093	.104	2.35	2.65	
A1	.004	.012	0.10	0.30	
B	.013	.020	0.33	0.51	
C	.009	.013	0.23	0.32	5
D	.496	.512	12.60	13.00	2
E	.291	.299	7.40	7.60	2
e	.050 BSC		1.27 BSC		
H	.394	.419	10.00	10.65	
h	.010	.029	0.25	0.75	
L	.016	.050	0.40	1.27	3
N	20		20		6
α	0°	8°	0°	8°	
ccc	—	.004	—	0.10	

Notes:

1. Dimensioning and tolerancing per ANSI Y14.5M-1982.
2. "D" and "E" do not include mold flash. Mold flash or protrusions shall not exceed .010 inch (0.25mm).
3. "L" is the length of terminal for soldering to a substrate.
4. Terminal numbers are shown for reference only.
5. "C" dimension does not include solder finish thickness.
6. Symbol "N" is the maximum number of terminals.

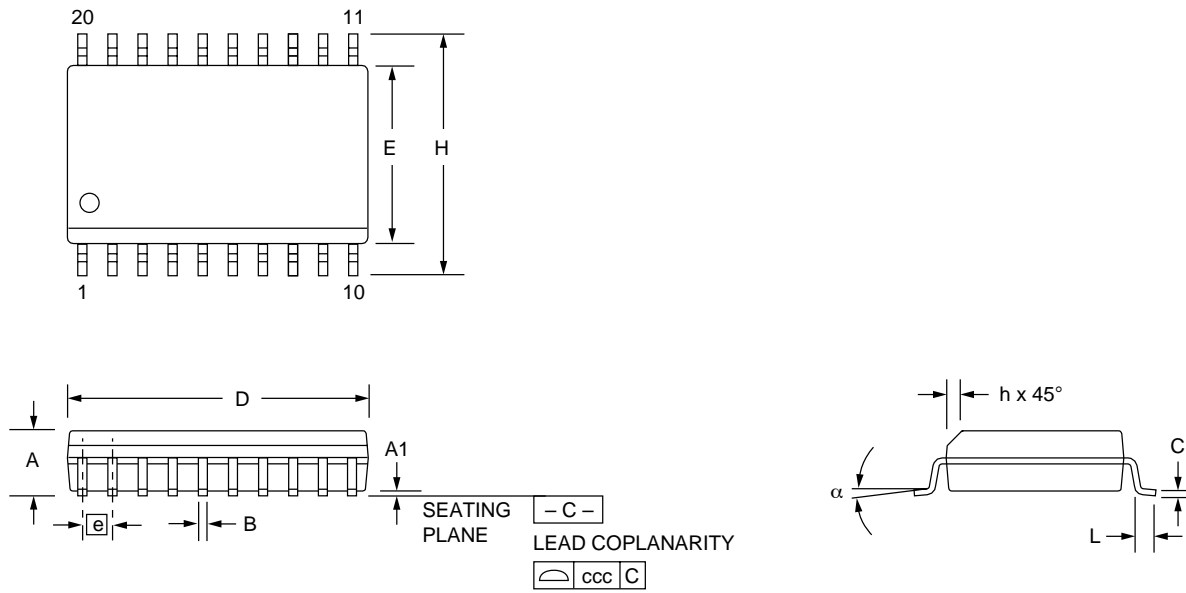

Mechanical Dimensions (continued)

20-Lead Ceramic DIP

Symbol	Inches		Millimeters		Notes
	Min.	Max.	Min.	Max.	
A	—	.200	—	5.08	
b1	.014	.023	.36	.58	8
b2	.045	.065	1.14	1.65	2, 8
c1	.008	.015	.20	.38	8
D	—	1.060	—	25.92	4
E	.220	.310	5.59	7.87	4
e	.100 BSC		2.54 BSC		5, 9
eA	.300 BSC		7.62 BSC		7
L	.125	.200	3.18	5.08	
Q	.015	.060	.38	1.52	3
s1	.005	—	.13	—	6
α	90°	105°	90°	105°	

Notes:

1. Index area: a notch or a pin one identification mark shall be located adjacent to pin one. The manufacturer's identification shall not be used as pin one identification mark.
2. The minimum limit for dimension "b2" may be .023(.58mm) for leads number 1, 10, 11 and 20 only.
3. Dimension "Q" shall be measured from the seating plane to the base plane.
4. This dimension allows for off-center lid, meniscus and glass overrun.
5. The basic pin spacing is .100 (2.54mm) between centerlines. Each pin centerline shall be located within $\pm .010$ (.25mm) of its exact longitudinal position relative to pins 1 and 20.
6. Applies to all four corner's (leads number 1, 10, 11, and 20).
7. "eA" shall be measured at the center of the lead bends or at the centerline of the leads when " α " is 90°.
8. All leads – Increase maximum limit by .003(.08mm) measured at the center of the flat, when lead finish is applied.
9. Eighteen spaces.

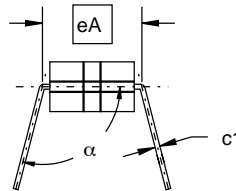
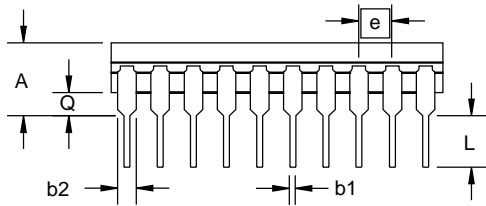
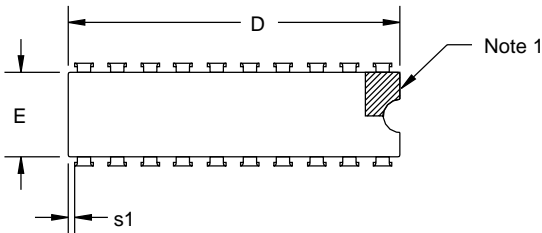

Mechanical Dimensions (continued)

20-Terminal LCC

Symbol	Inches		Millimeters		Notes
	Min.	Max.	Min.	Max.	
A	.060	.100	1.52	2.54	3, 6
A1	.050	.088	1.27	2.24	3, 6
B1	.022	.028	.56	.71	2
B3	.006	.022	.15	.56	2, 5
D/E	.342	.358	8.69	9.09	
D1/E1	.200 BSC		5.08 BSC		
D2/E2	.100 BSC		2.54 BSC		
D3/E3	—	.358	—	9.09	
e	.050 BSC		1.27 BSC		
h	.040 REF		1.02 REF		4
j	.020 REF		.51 REF		4
L1	.045	.055	1.14	1.40	
L2	.075	.095	1.91	2.41	
L3	.003	.015	.08	.38	5
ND/NE	5		5		
N	20		20		

Notes:

- ① The index feature for terminal 1 identification, optical orientation or handling purposes, shall be within the shaded index areas shown on planes 1 and 2. Plane 1, terminal 1 identification may be an extension of the length of the metallized terminal which shall not be wider than the B1 dimension.
2. Unless otherwise specified, a minimum clearance of .015 inch (0.38mm) shall be maintained between all metallized features (e.g., lid, castellations, terminals, thermal pads, etc.).
3. Dimension "A" controls the overall package thickness. The maximum "A" dimension is the package height before being solder dipped.
- ④ The corner shape (square, notch, radius, etc.) may vary at the manufacturer's option, from that shown on the drawing. The index corner shall be clearly unique.
5. Dimension "B3" minimum and "L3" minimum and the appropriately derived castellation length define an unobstructed three dimensional space traversing all of the ceramic layers in which a castellation was designed. Dimensions "B3" and "L3" maximum define the maximum width and depth of the castellation at any point on its surface. Measurement of these dimensions may be made prior to solder dripping.
6. Chip carriers shall be constructed of a minimum of two ceramic layers.

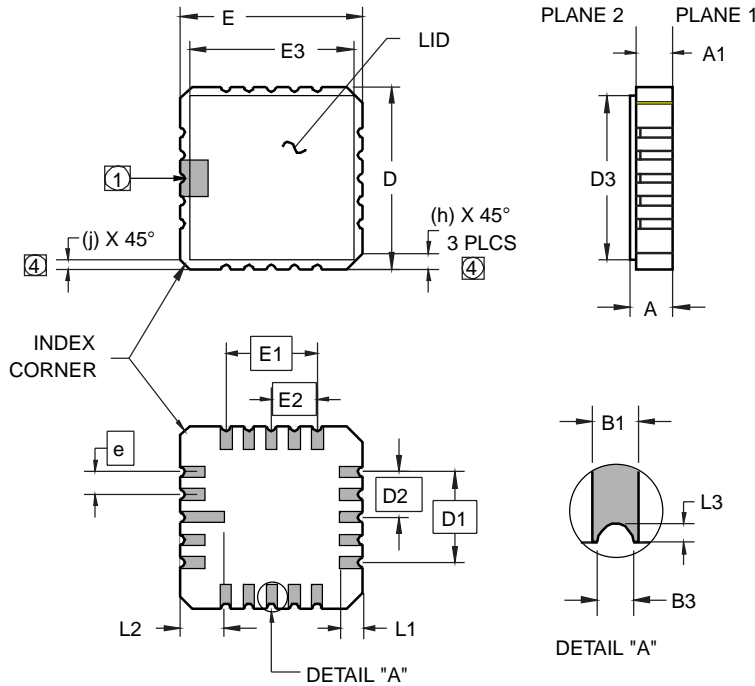

Ordering Information

Part Number	Package	Operating Temperature Range
RV3283M	20 Lead SOIC	-40°C to +85°C
RM3283D	20 Lead Ceramic DIP	-55°C to +125°C
RM3283L	20 Terminal Leadless Chip Carrier	-55°C to +125°C

LIFE SUPPORT POLICY

FAIRCHILD'S PRODUCTS ARE NOT AUTHORIZED FOR USE AS CRITICAL COMPONENTS IN LIFE SUPPORT DEVICES OR SYSTEMS WITHOUT THE EXPRESS WRITTEN APPROVAL OF THE PRESIDENT OF FAIRCHILD SEMICONDUCTOR CORPORATION. As used herein:

1. Life support devices or systems are devices or systems which, (a) are intended for surgical implant into the body, or (b) support or sustain life, and (c) whose failure to perform when properly used in accordance with instructions for use provided in the labeling, can be reasonably expected to result in a significant injury of the user.
2. A critical component in any component of a life support device or system whose failure to perform can be reasonably expected to cause the failure of the life support device or system, or to affect its safety or effectiveness.