

TOSHIBA Transistor Silicon NPN Epitaxial Type (PCT Process)

RN1101F, RN1102F, RN1103F RN1104F, RN1105F, RN1106F

Switching, Inverter Circuit, Interface Circuit
And Driver Circuit Applications

- With built-in bias resistors
- Simplify circuit design
- Reduce a quantity of parts and manufacturing process
- Complementary to RN2101F~RN2106F

Equivalent Circuit And Bias Resister Values

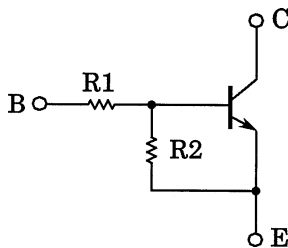

Type No.	R1 (kΩ)	R2 (kΩ)
RN1101F	4.7	4.7
RN1102F	10	10
RN1103F	22	22
RN1104F	47	47
RN1105F	2.2	47
RN1106F	4.7	47

Unit in mm

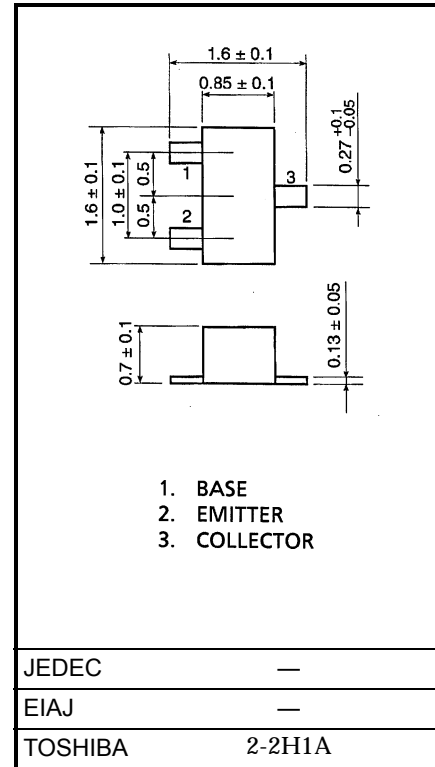

Weight: 2.3 mg

Maximum Ratings (Ta = 25°C)

Characteristic	Symbol	Rating	Unit
Collector-base voltage	V_{CBO}	50	V
Collector-emitter voltage	V_{CEO}	50	V
Emitter-base voltage	V_{EBO}	10	V
		5	
Collector current	I_C	100	mA
Collector power dissipation	P_C	100	mW
Junction temperature	T_j	150	°C
Storage temperature range	T_{stg}	-55~150	°C

000707EAA2

- TOSHIBA is continually working to improve the quality and reliability of its products. Nevertheless, semiconductor devices in general can malfunction or fail due to their inherent electrical sensitivity and vulnerability to physical stress. It is the responsibility of the buyer, when utilizing TOSHIBA products, to comply with the standards of safety in making a safe design for the entire system, and to avoid situations in which a malfunction or failure of such TOSHIBA products could cause loss of human life, bodily injury or damage to property.
In developing your designs, please ensure that TOSHIBA products are used within specified operating ranges as set forth in the most recent TOSHIBA products specifications. Also, please keep in mind the precautions and conditions set forth in the "Handling Guide for Semiconductor Devices," or "TOSHIBA Semiconductor Reliability Handbook" etc..
- The TOSHIBA products listed in this document are intended for usage in general electronics applications (computer, personal equipment, office equipment, measuring equipment, industrial robotics, domestic appliances, etc.). These TOSHIBA products are neither intended nor warranted for usage in equipment that requires extraordinarily high quality and/or reliability or a malfunction or failure of which may cause loss of human life or bodily injury ("Unintended Usage"). Unintended Usage include atomic energy control instruments, airplane or spaceship instruments, transportation instruments, traffic signal instruments, combustion control instruments, medical instruments, all types of safety devices, etc.. Unintended Usage of TOSHIBA products listed in this document shall be made at the customer's own risk.

Electrical Characteristics (Ta = 25°C)

Characteristic		Symbol	Test Circuit	Test Condition	Min	Typ.	Max	Unit
Collector cut-off current	RN1101F ~1106F	I_{CBO}	—	$V_{CB} = 50V, I_E = 0$	—	—	100	nA
		I_{CEO}		$V_{CE} = 50V, I_B = 0$	—	—	500	
Emitter cut-off current	RN1101F	I_{EBO}	—	$V_{EB} = 10V, I_C = 0$	0.82	—	1.52	mA
	RN1102F				0.38	—	0.71	
	RN1103F				0.17	—	0.33	
	RN1104F				0.082	—	0.15	
	RN1105F			$V_{EB} = 5V, I_C = 0$	0.078	—	0.145	
	RN1106F				0.074	—	0.138	
DC current gain	RN1101F	h_{FE}	—	$V_{CE} = 5V, I_C = 10mA$	30	—	—	—
	RN1102F				50	—	—	
	RN1103F				70	—	—	
	RN1104F				80	—	—	
	RN1105F				80	—	—	
	RN1106F				80	—	—	
Collector-emitter saturation voltage	RN1101F ~1106F	$V_{CE(sat)}$	—	$I_C = 5mA, I_B = 0.25mA$	—	0.1	0.3	V
Input voltage (ON)	RN1101F	$V_{I(ON)}$	—	$V_{CE} = 0.2V, I_C = 5mA$	1.1	—	2.0	V
	RN1102F				1.2	—	2.4	
	RN1103F				1.3	—	3.0	
	RN1104F				1.5	—	5.0	
	RN1105F				0.6	—	1.1	
	RN1106F				0.7	—	1.3	
Input voltage (OFF)	RN1101F ~1104F	$V_{I(OFF)}$	—	$V_{CE} = 5V, I_C = 0.1mA$	1.0	—	1.5	V
	RN1105F, 1106F				0.5	—	0.8	
Transition frequency	RN1101F ~1106F	f_T	—	$V_{CE} = 10V, I_C = 5mA$	—	250	—	MHz
Collector Output capacitance	RN1101F ~1106F	C_{ob}	—	$V_{CB} = 10V, I_E = 0,$ $f = 1MHz$	—	3	6	pF
Input resistor	RN1101F	R1	—	—	3.29	4.7	6.11	kΩ
	RN1102F				7	10	13	
	RN1103F				15.4	22	28.6	
	RN1104F				32.9	47	61.1	
	RN1105F				1.54	2.2	2.86	
	RN1106F				3.29	4.7	6.11	
Resistor ratio	RN1101F ~1104F	R1/R2	—	—	0.9	1.0	1.1	
	RN1105F				0.0421	0.0468	0.0515	
	RN1106F				0.09	0.1	0.11	

000707EAA2

- The information contained herein is presented only as a guide for the applications of our products. No responsibility is assumed by TOSHIBA CORPORATION for any infringements of intellectual property or other rights of the third parties which may result from its use. No license is granted by implication or otherwise under any intellectual property or other rights of TOSHIBA CORPORATION or others.
- The information contained herein is subject to change without notice.

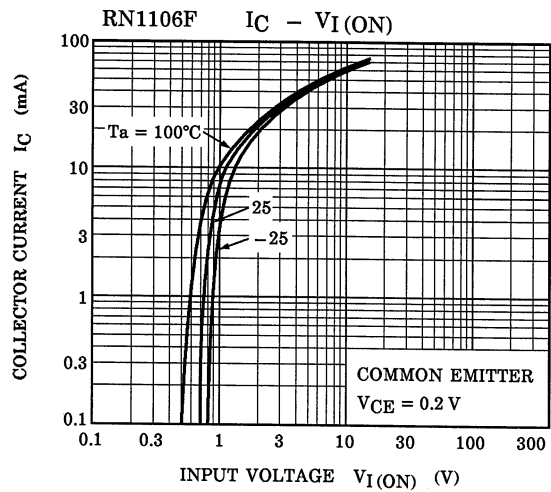
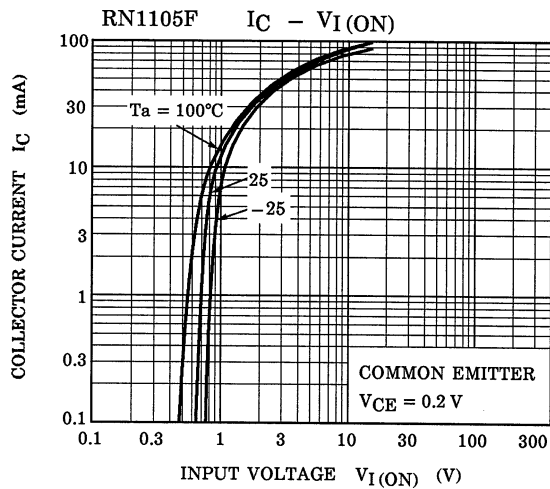
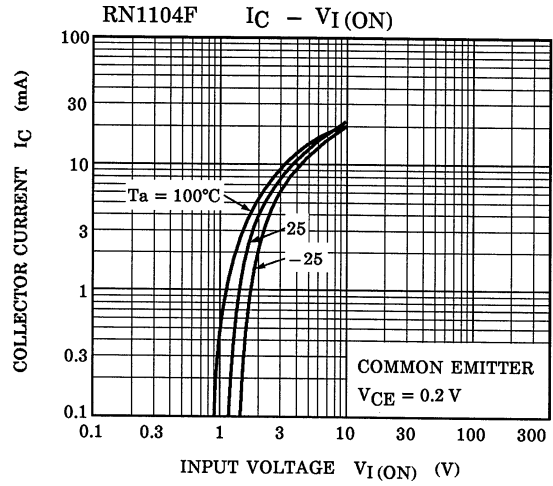
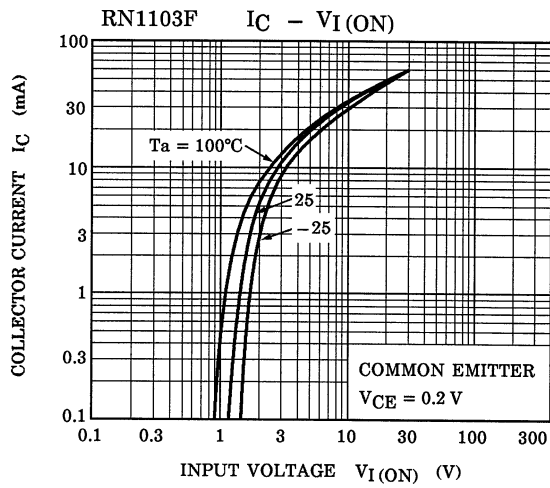
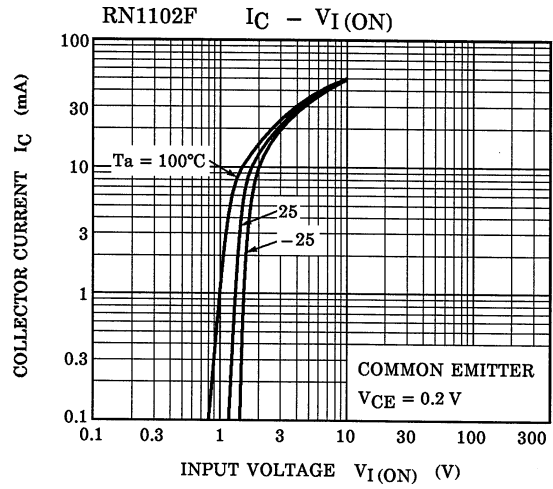
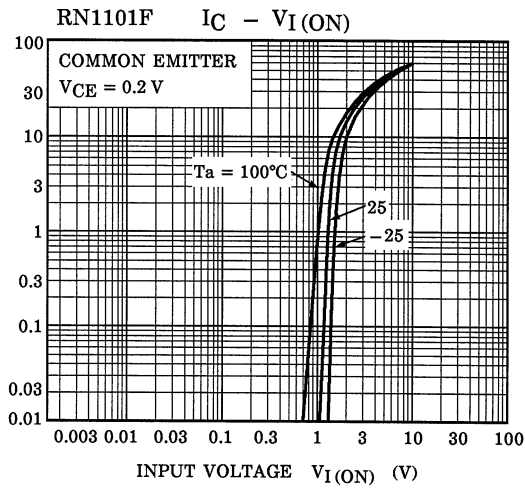

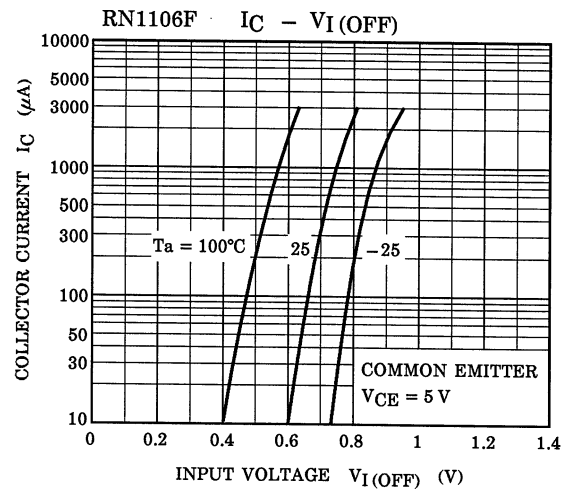
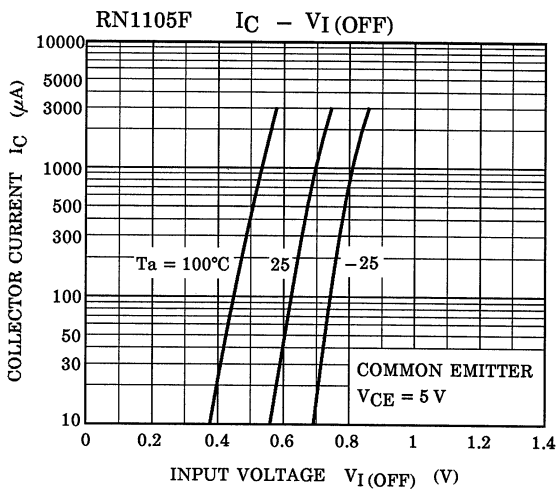
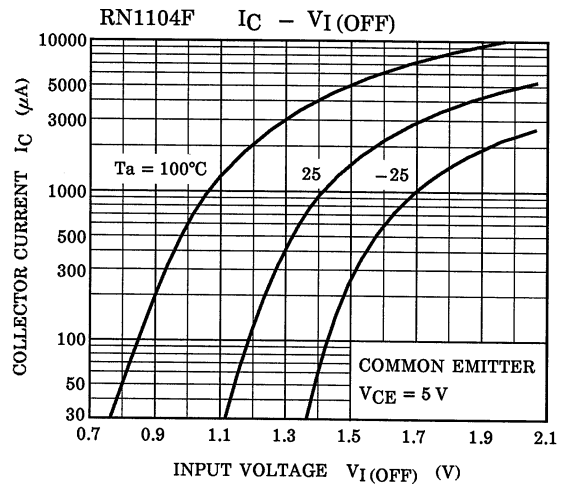
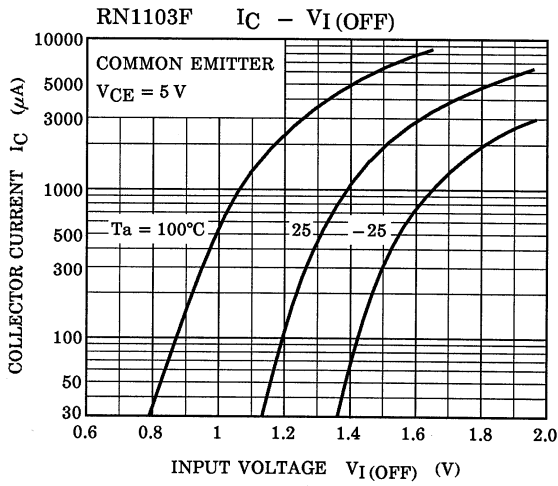
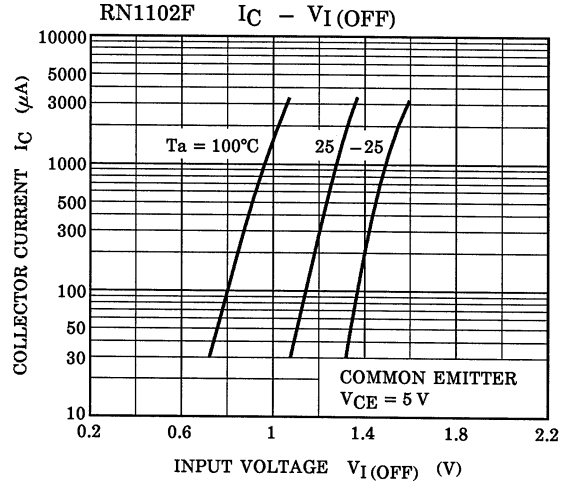
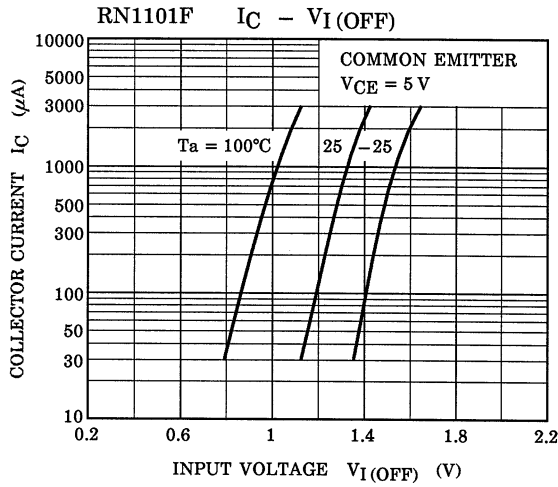

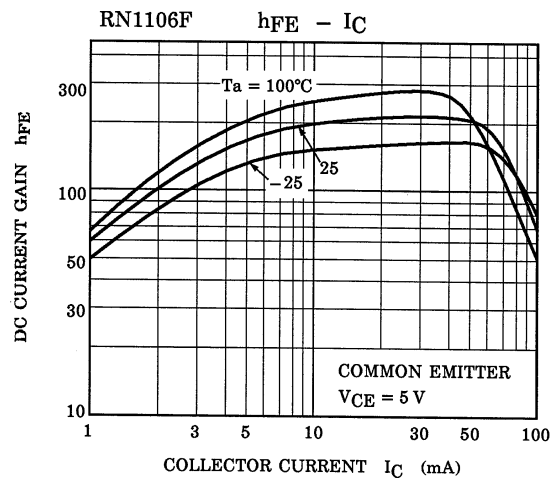
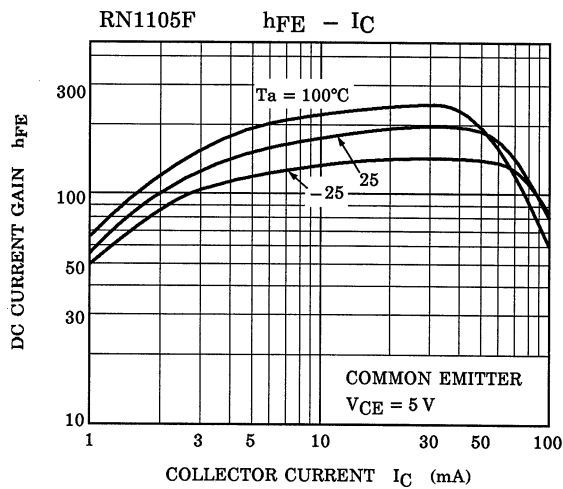
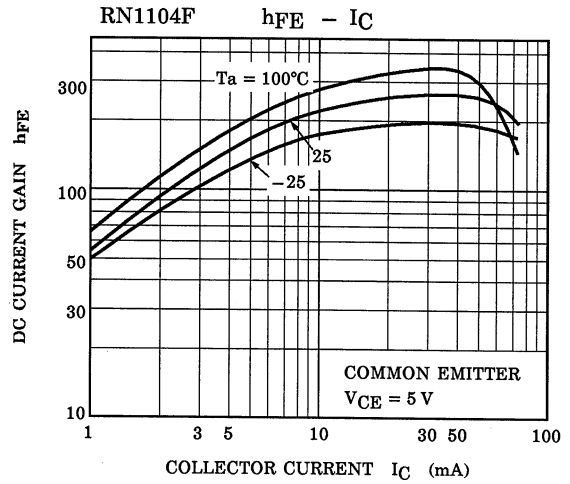
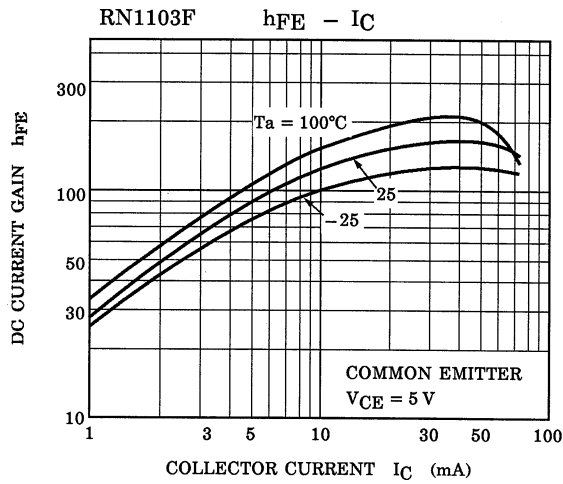
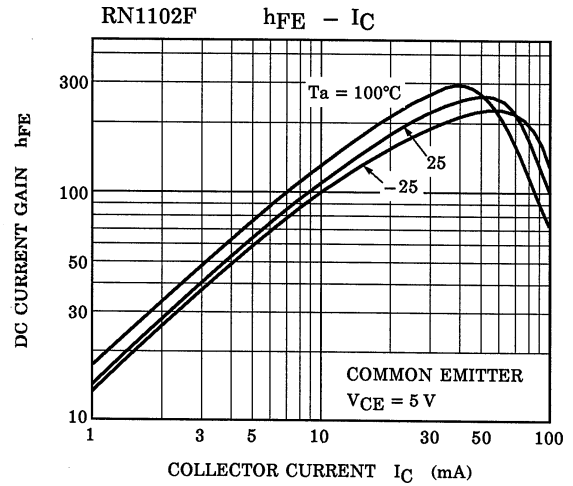
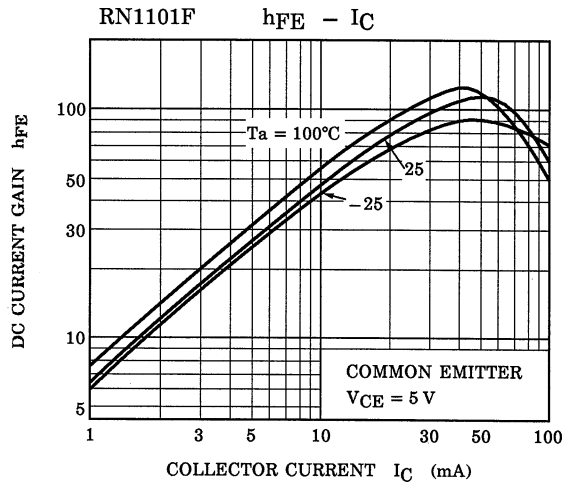

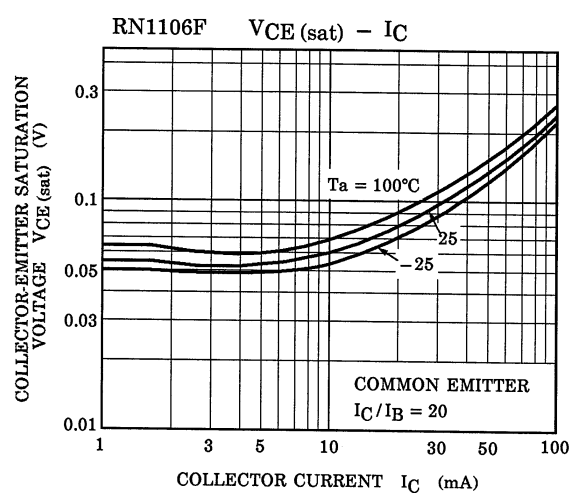
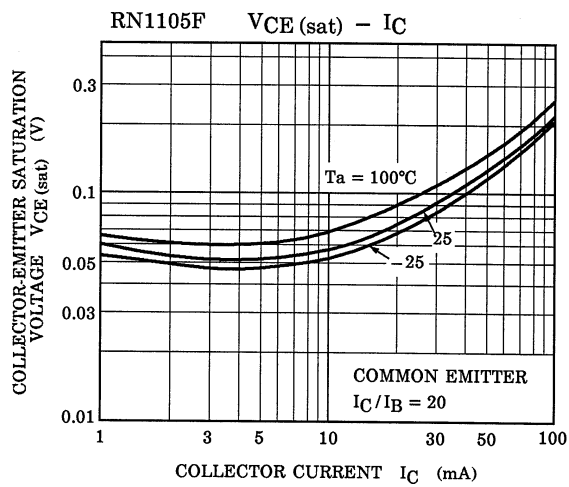
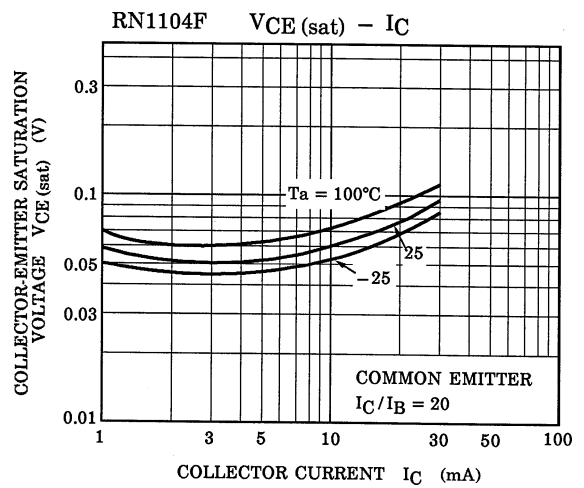
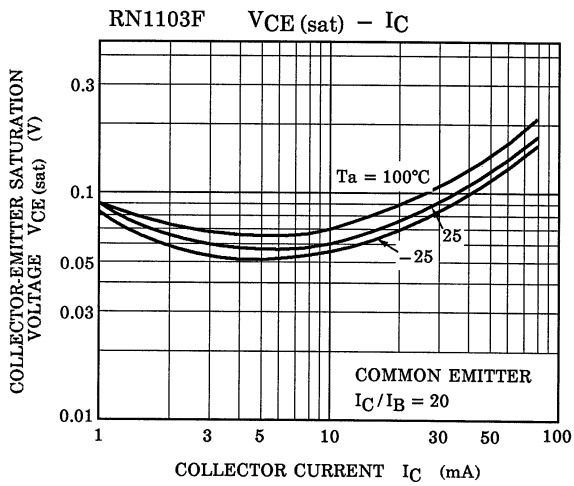
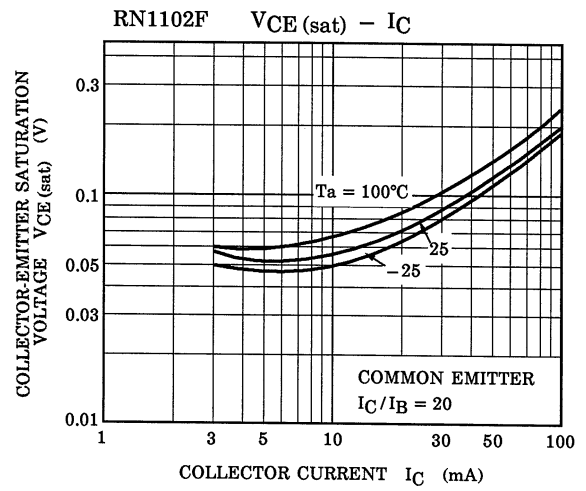
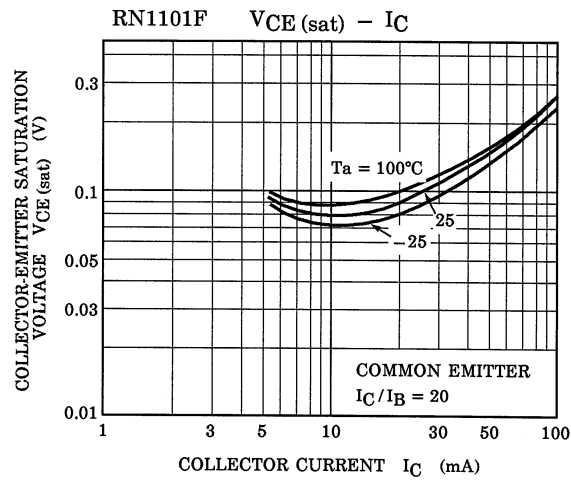

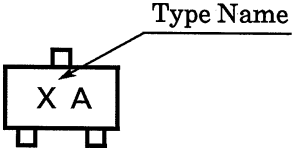
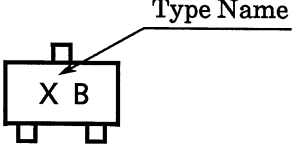
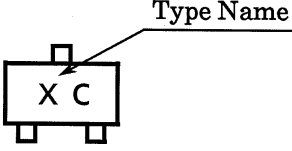
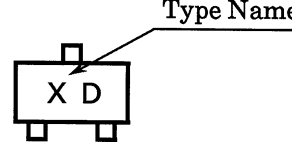
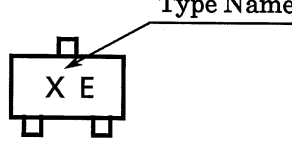
Type Name	Marking
RN1101F	
RN1102F	
RN1103F	
RN1104F	
RN1105F	
RN1106F	