

TOSHIBA Transistor Silicon NPN Epitaxial Type (PCT Process)

RN1107, RN1108, RN1109

Switching, Inverter Circuit, Interface Circuit
And Driver Circuit Applications

Unit in mm

- With built-in bias resistors.
- Simplify circuit design
- Reduce a quantity of parts and manufacturing process
- Complementary to RN2107~2109

Equivalent Circuit and Bias Resistor Values

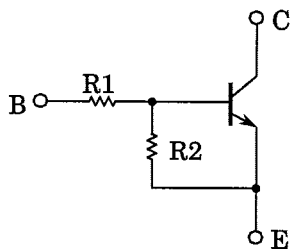

Type No.	R1 (kΩ)	R2 (kΩ)
RN1107	10	47
RN1108	22	47
RN1109	47	22

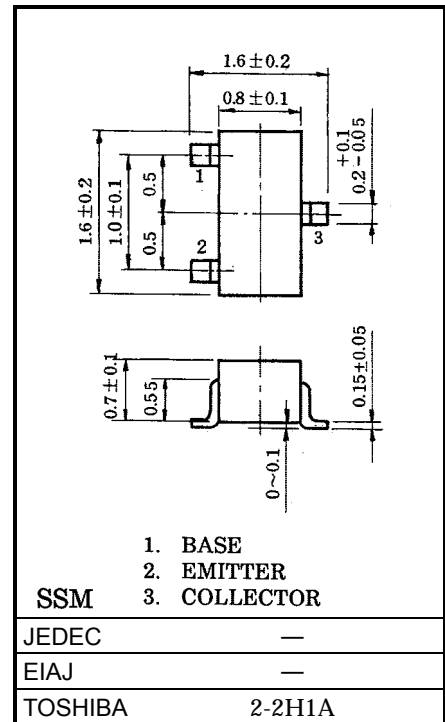

Weight: 2.4mg

Maximum Ratings (Ta = 25°C)

Characteristic	Symbol	Rating	Unit	
Collector-base voltage	RN1107~1109	V _{CBO}	50	V
Collector-emitter voltage	RN1107~1109	V _{CEO}	50	V
Emitter-base voltage	RN1107	V _{EBO}	6	V
	RN1108		7	
	RN1109		15	
Collector current	RN1107~1109	I _c	100	mA
Collector power dissipation	RN1107~1109	P _C	100	mW
Junction temperature	RN1107~1109	T _j	150	°C
Storage temperature range	RN1107~1109	T _{stg}	-55~150	°C

961001EAA2

- TOSHIBA is continually working to improve the quality and the reliability of its products. Nevertheless, semiconductor devices in general can malfunction or fail due to their inherent electrical sensitivity and vulnerability to physical stress. It is the responsibility of the buyer, when utilizing TOSHIBA products, to observe standards of safety, and to avoid situations in which a malfunction or failure of a TOSHIBA product could cause loss of human life, bodily injury or damage to property. In developing your designs, please ensure that TOSHIBA products are used within specified operating ranges as set forth in the most recent products specifications. Also, please keep in mind the precautions and conditions set forth in the TOSHIBA Semiconductor Reliability Handbook.
- The information contained herein is presented only as a guide for the applications of our products. No responsibility is assumed by TOSHIBA CORPORATION for any infringements of intellectual property or other rights of the third parties which may result from its use. No license is granted by implication or otherwise under any intellectual property or other rights of TOSHIBA CORPORATION or others.
- The information contained herein is subject to change without notice.

Electrical Characteristics (Ta = 25°C)

Characteristic		Symbol	Test Circuit	Test Condition	Min	Typ.	Max	Unit
Collector cut-off current	RN1107~1109	I_{CBO}	—	$V_{CB} = 50V, I_E = 0$	—	—	100	nA
		I_{CEO}	—	$V_{CE} = 50V, I_B = 0$	—	—	500	nA
Emitter cut-off current	RN1107	I_{EBO}	—	$V_{EB} = 6V, I_C = 0$	0.081	—	0.15	mA
	RN1108		—	$V_{EB} = 7V, I_C = 0$	0.078	—	0.145	
	RN1109		—	$V_{EB} = 15V, I_C = 0$	0.167	—	0.311	
DC current gain	RN1107	h_{FE}	—	$V_{CE} = 5V, I_C = 10mA$	80	—	—	—
	RN1108		—		80	—	—	
	RN1109		—		70	—	—	
Collector-emitter saturation voltage	RN1107~1109	$V_{CE(sat)}$	—	$I_C = 5mA, I_B = 0.25mA$	—	0.1	0.3	V
Input voltage (ON)	RN1107	$V_{I(ON)}$	—	$V_{CE} = 0.2V, I_C = 5mA$	0.7	—	1.8	V
	RN1108		—		1.0	—	2.6	
	RN1109		—		2.2	—	5.8	
Input voltage (OFF)	RN1107	$V_{I(OFF)}$	—	$V_{CE} = 5V, I_C = 0.1mA$	0.5	—	1.0	V
	RN1108		—		0.6	—	1.16	
	RN1109		—		1.5	—	2.6	
Translation frequency	RN1107~1109	f_T	—	$V_{CE} = 10V, I_C = 5mA$	—	250	—	MHz
Collector output capacitance	RN1107~1109	C_{ob}	—	$V_{CB} = 10V, I_E = 0, f = 1MHz$	—	3	6	pF
Input Resistor	RN1107	R1	—	—	7	10	13	kΩ
	RN1108		—		15.4	22	28.6	
	RN1109		—		32.9	47	61.1	
Resistor Ratio	RN1107	R1/R2	—	—	0.191	0.213	0.232	—
	RN1108		—		0.421	0.468	0.515	
	RN1109		—		1.92	2.14	2.35	

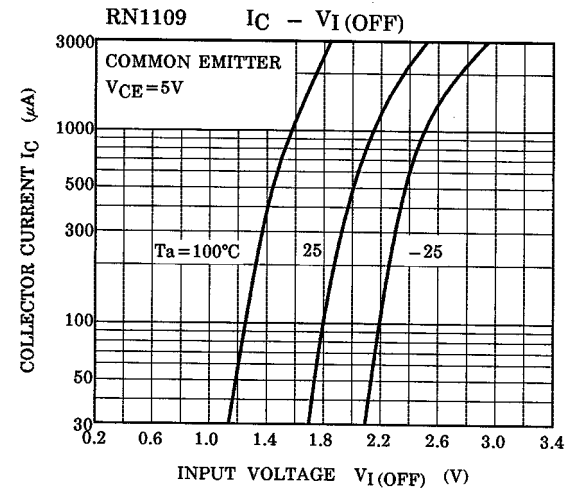
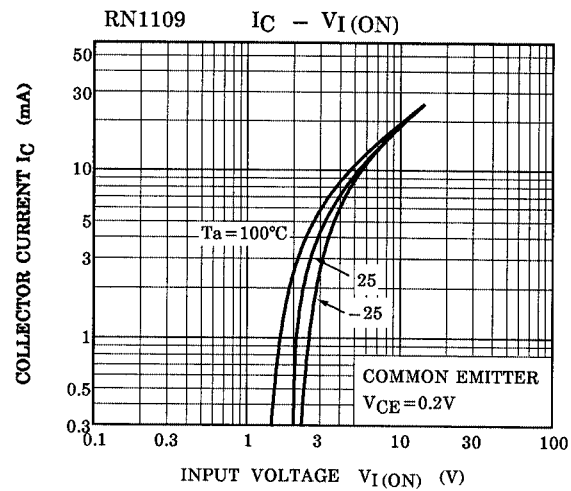
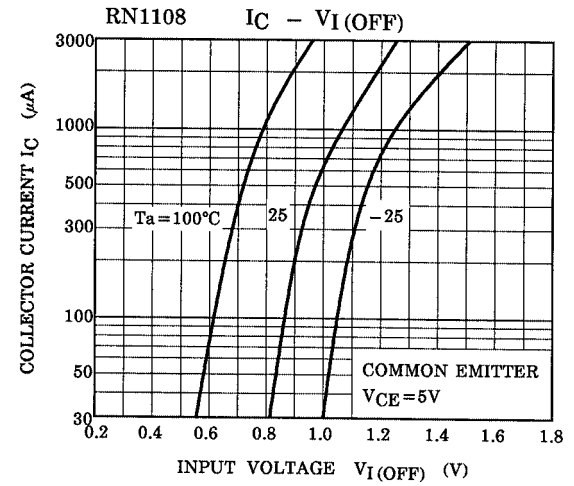
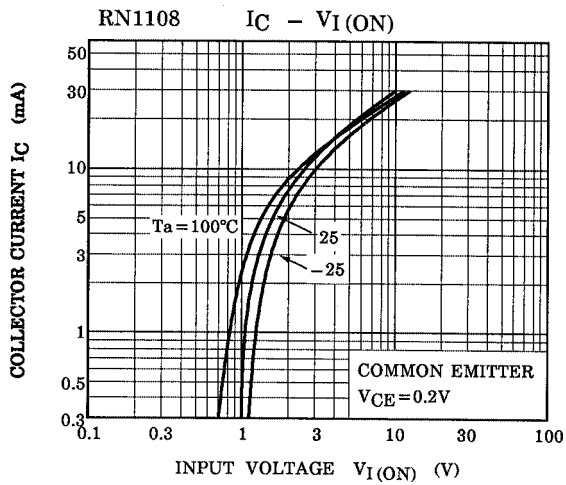
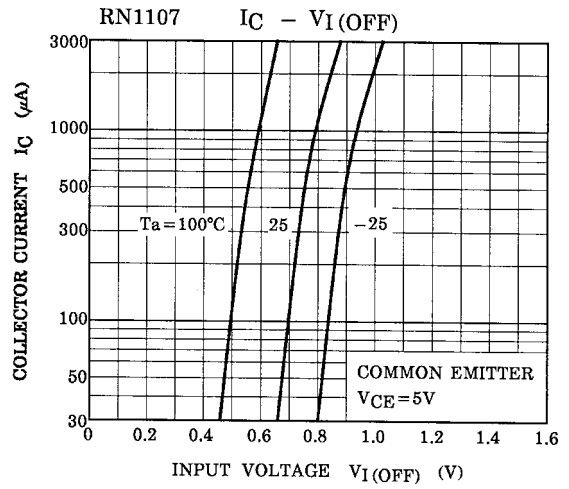
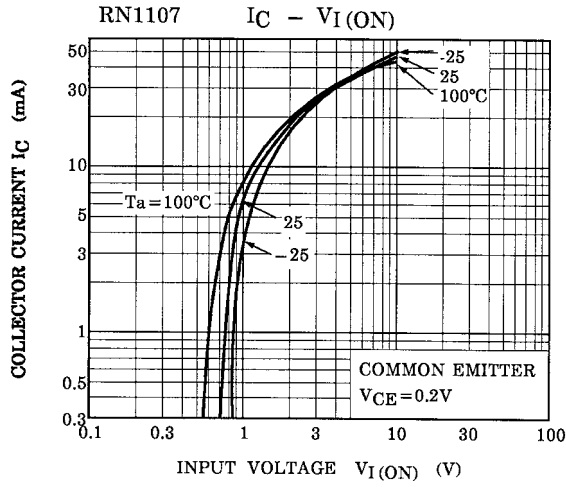

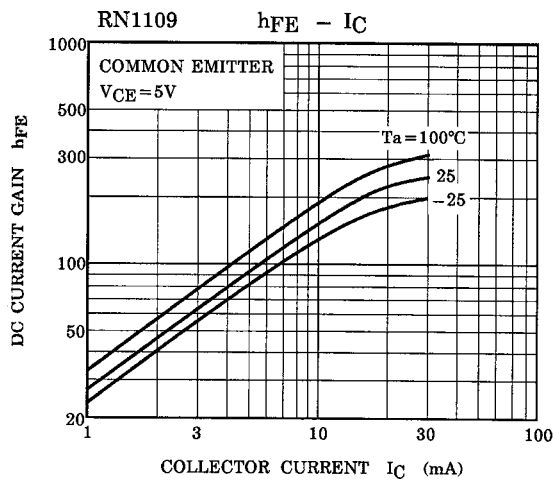
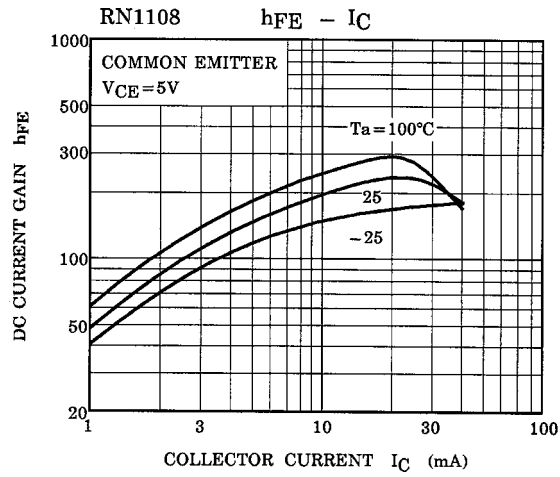
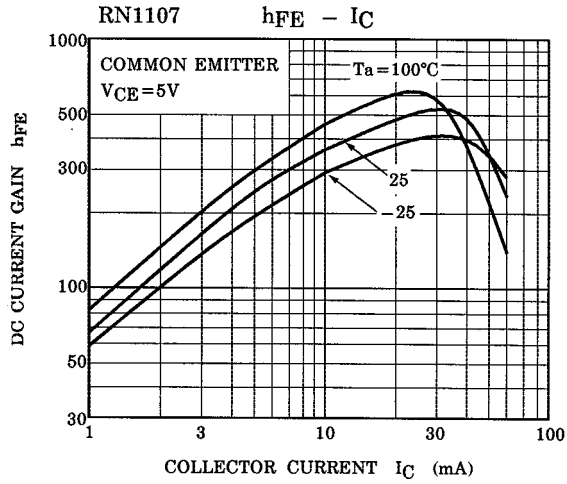

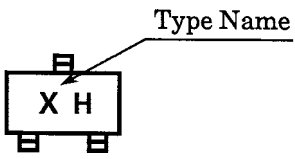
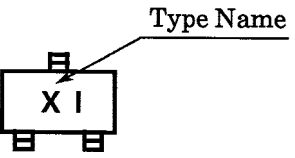
Type Name	Marking
RN1107	
RN1108	
RN1109	