

TOSHIBA Transistor Silicon NPN Epitaxial Type (PCT Process)

RN1107F, RN1108F, RN1109F

Switching, Inverter Circuit, Interface Circuit
And Driver Circuit Applications

Unit in mm

- With built-in bias resistors.
- Simplify circuit design
- Reduce a quantity of parts and manufacturing process
- Complementary to RN2107F~2109F

Equivalent Circuit and Bias Resistor Values

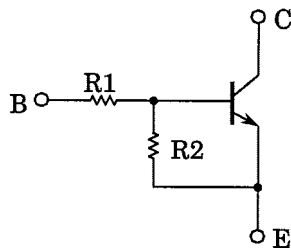

Type No.	R1 (kΩ)	R2 (kΩ)
RN1107F	10	47
RN1108F	22	47
RN1109F	47	22

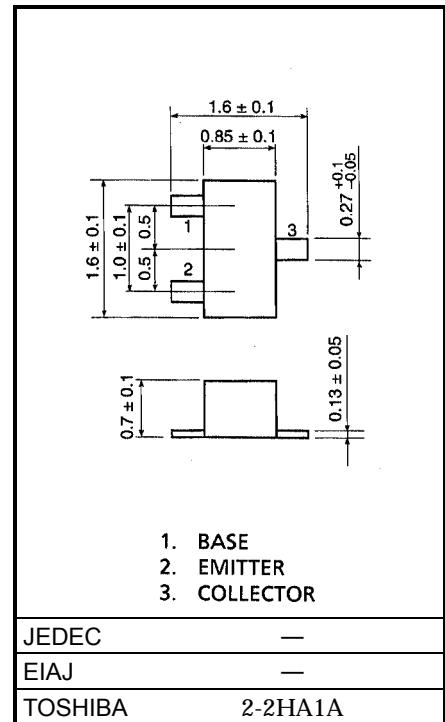

Maximum Ratings (Ta = 25°C)

Characteristic	Symbol	Rating	Unit	
Collector-base voltage	RN1107F~1109F	V _{CBO}	50	V
Collector-emitter voltage	RN1107F~1109F	V _{CEO}	50	V
Emitter-base voltage	RN1107F	V _{EBO}	6	V
	RN1108F		7	
	RN1109F		15	
Collector current	RN1107F~1109F	I _c	100	mA
Collector power dissipation	RN1107F~1109F	P _c	100	mW
Junction temperature	RN1107F~1109F	T _j	150	°C
Storage temperature range	RN1107F~1109F	T _{stg}	-55~150	°C

961001EAA1

- TOSHIBA is continually working to improve the quality and the reliability of its products. Nevertheless, semiconductor devices in general can malfunction or fail due to their inherent electrical sensitivity and vulnerability to physical stress. It is the responsibility of the buyer, when utilizing TOSHIBA products, to observe standards of safety, and to avoid situations in which a malfunction or failure of a TOSHIBA product could cause loss of human life, bodily injury or damage to property. In developing your designs, please ensure that TOSHIBA products are used within specified operating ranges as set forth in the most recent products specifications. Also, please keep in mind the precautions and conditions set forth in the TOSHIBA Semiconductor Reliability Handbook.
- The information contained herein is presented only as a guide for the applications of our products. No responsibility is assumed by TOSHIBA CORPORATION for any infringements of intellectual property or other rights of the third parties which may result from its use. No license is granted by implication or otherwise under any intellectual property or other rights of TOSHIBA CORPORATION or others.
- The information contained herein is subject to change without notice.

Electrical Characteristics (Ta = 25°C)

Characteristic		Symbol	Test Circuit	Test Condition	Min	Typ.	Max	Unit
Collector cut-off current	RN1107F~1109F	I_{CBO}	—	$V_{CB} = 50V, I_E = 0$	—	—	100	nA
		I_{CEO}	—	$V_{CE} = 50V, I_B = 0$	—	—	500	nA
Emitter cut-off current	RN1107F	I_{EBO}	—	$V_{EB} = 6V, I_C = 0$	0.081	—	0.15	mA
	RN1108F		—	$V_{EB} = 7V, I_C = 0$	0.078	—	0.145	
	RN1109F		—	$V_{EB} = 15V, I_C = 0$	0.167	—	0.311	
DC current gain	RN1107F	h_{FE}	—	$V_{CE} = 5V, I_C = 10mA$	80	—	—	—
	RN1108F		—		80	—	—	
	RN1109F		—		70	—	—	
Collector-emitter saturation voltage	RN1107F~1109F	$V_{CE(sat)}$	—	$I_C = 5mA, I_B = 0.25mA$	—	0.1	0.3	V
Input voltage (ON)	RN1107F	$V_{I(ON)}$	—	$V_{CE} = 0.2V, I_C = 5mA$	0.7	—	1.8	V
	RN1108F		—		1.0	—	2.6	
	RN1109F		—		2.2	—	5.8	
Input voltage (OFF)	RN1107F	$V_{I(OFF)}$	—	$V_{CE} = 5V, I_C = 0.1mA$	0.5	—	1.0	V
	RN1108F		—		0.6	—	1.16	
	RN1109F		—		1.5	—	2.6	
Translation frequency	RN1107F~1109F	f_T	—	$V_{CE} = 10V, I_C = 5mA$	—	250	—	MHz
Collector output capacitance	RN1107F~1109F	C_{ob}	—	$V_{CB} = 10V, I_E = 0, f = 1MHz$	—	3	6	pF
Input Resistor	RN1107F	R1	—	—	7	10	13	kΩ
	RN1108F		—		15.4	22	28.6	
	RN1109F		—		32.9	47	61.1	
Resistor Ratio	RN1107F	R1/R2	—	—	0.191	0.213	0.232	—
	RN1108F		—		0.421	0.468	0.515	
	RN1109F		—		1.92	2.14	2.35	

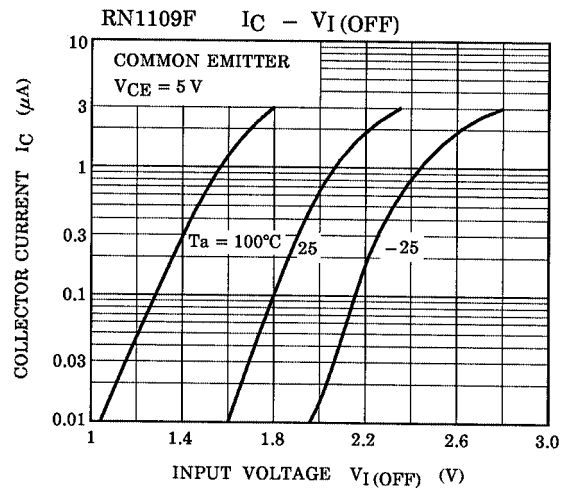
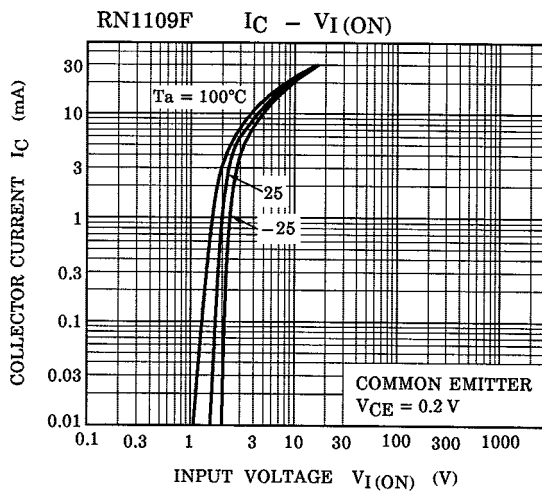
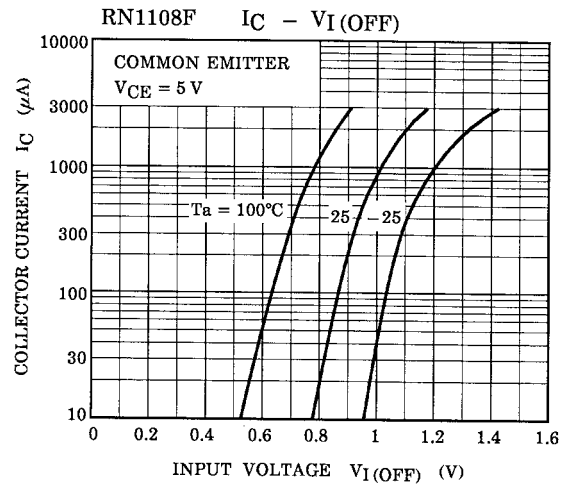
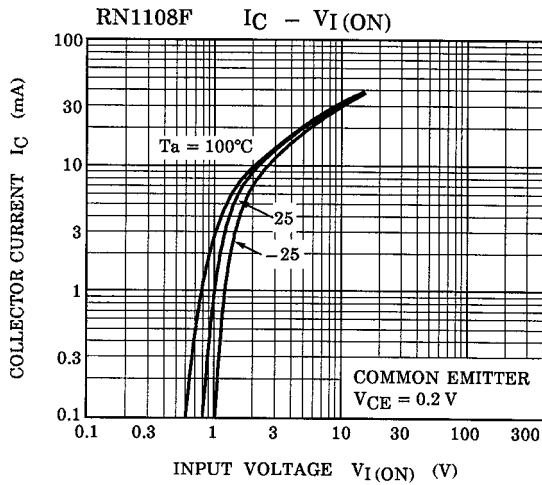
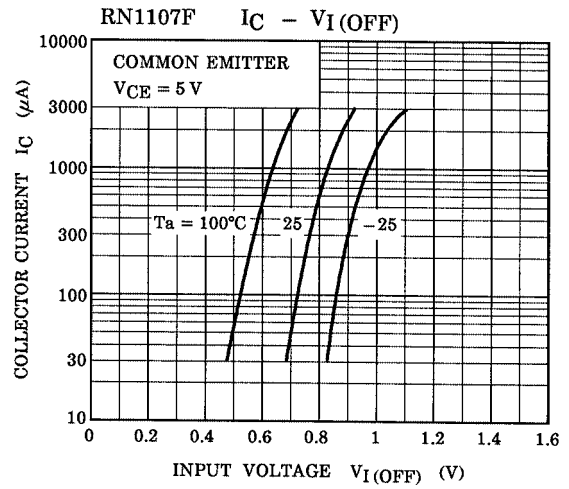
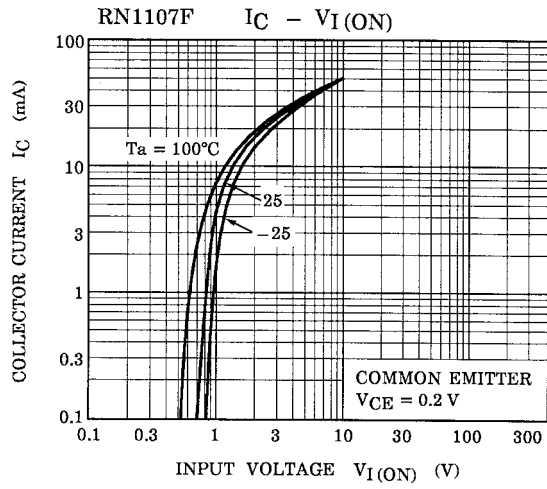

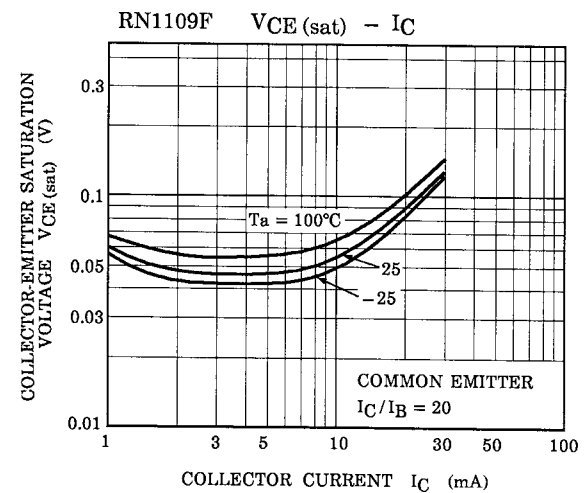
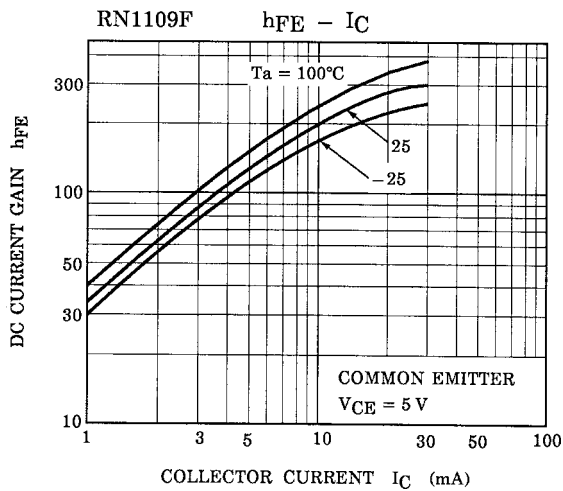
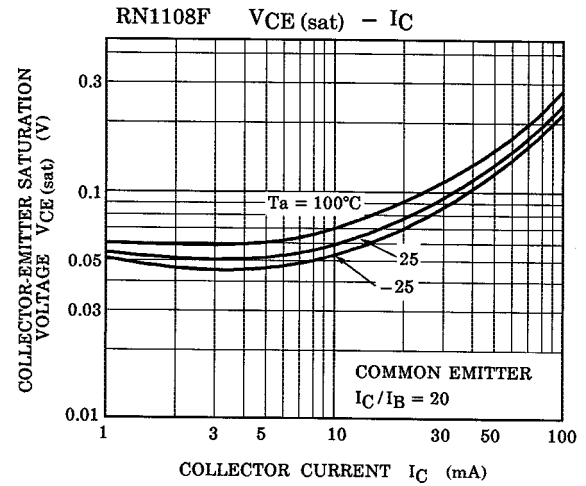
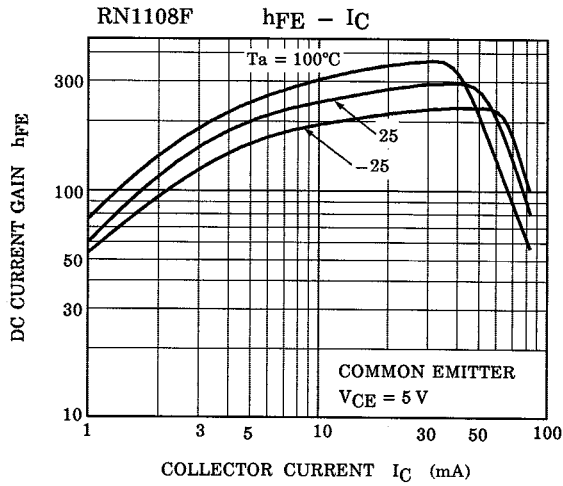
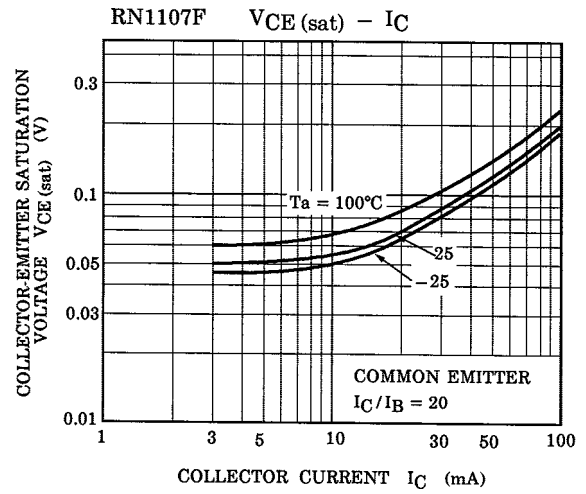
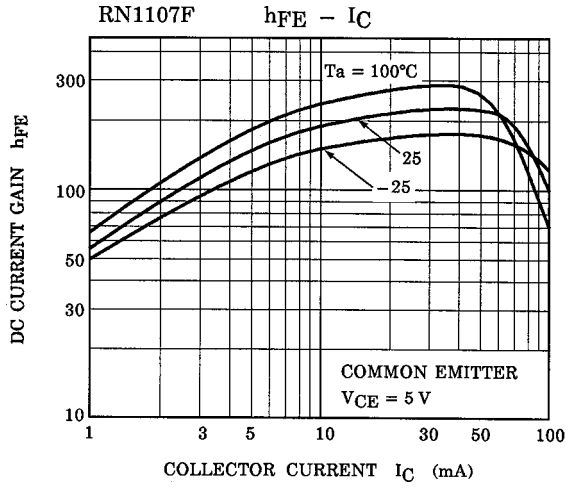

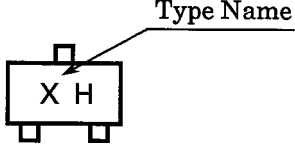
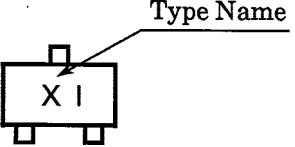
Type Name	Marking
RN1107F	
RN1108F	
RN1109F	